

# Agilent HSMx-A10x-xxxxx PLCC-2 Surface Mount LED Indicator Data Sheet

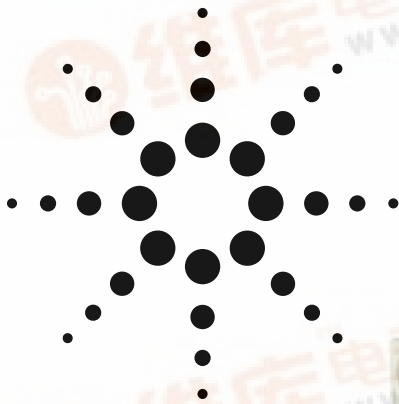

## Description

This family of SMT LEDs is packaged in the industry standard PLCC-2 package. These SMT LEDs have high reliability performance and are designed to work under a wide range of environmental conditions. This high reliability feature makes them ideally suited to be used under harsh interior automotive as well as interior signs application conditions.

To facilitate easy pick & place assembly, the LEDs are packed in EIA-compliant tape and reel. Every reel will be shipped in single intensity and color bin, except red color, to provide close uniformity.

These LEDs are compatible with IR solder reflow process. Due to the high reliability feature of these products, they can also be mounted using through-the-wave soldering process.

The super wide viewing angle at 120° makes these LEDs ideally suited for panel, push button, or general backlighting in automotive interior, office equipment, industrial equipment, and home appliances. The flat top emitting surface makes it easy for these LEDs to mate with light pipes. With the built-in reflector pushing up the intensity of the light output, these LEDs are also suitable to be used as LED pixels in interior electronic signs.

## Features

- Industry standard PLCC-2 package
- High reliability LED package
- High brightness using AlInGaP and InGaN dice technologies
- Available in full selection of colors
- Super wide viewing angle at 120°
- Available in 8 mm carrier tape on 7 inch reel (2000 pieces)
- Compatible with both IR and TTV soldering process

## Applications

- Interior automotive
  - Instrument panel backlighting
  - Central console backlighting
  - Cabin backlighting
- Electronic signs and signals
  - Interior full color sign
  - Variable message sign
- Office automation, home appliances, industrial equipment
  - Front panel backlighting
  - Push button backlighting
  - Display backlighting

**CAUTION:** HSMN,M,K and E-A10x-xxxxxx LEDs are Class 2 ESD sensitive. Please observe appropriate precautions during handling and processing. Refer to Agilent Application Note AN-1142 for additional details.

**Package Dimensions**

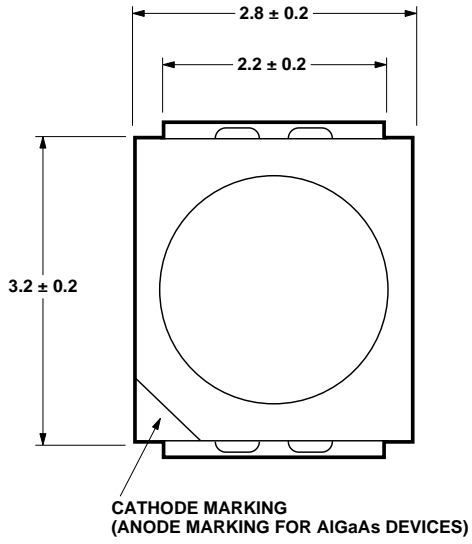

**TOP MOUNT**

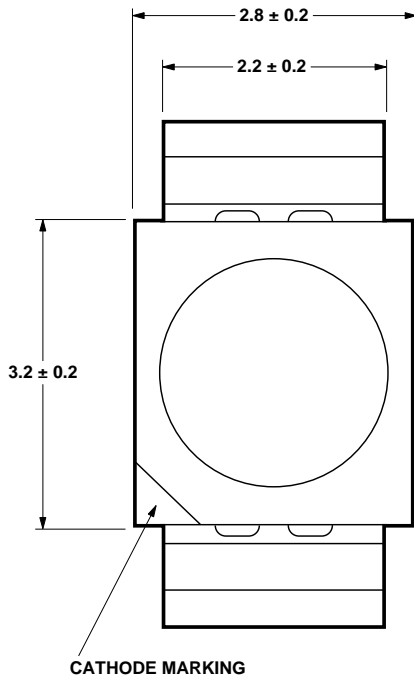
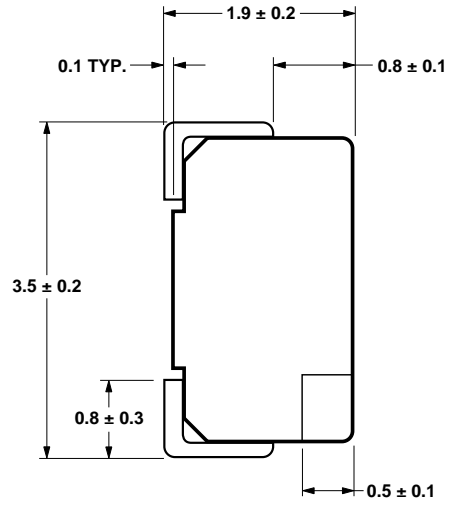

**REVERSE MOUNT**

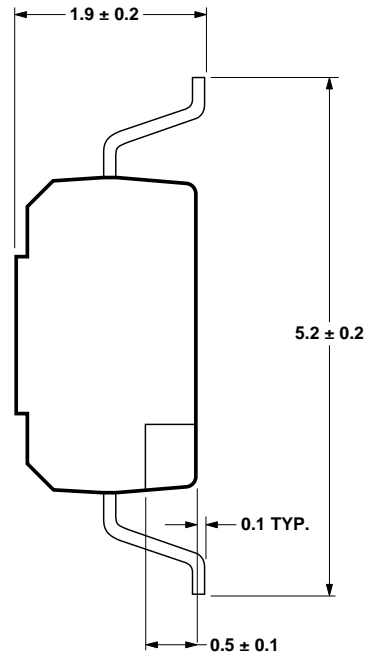

**NOTE: ALL DIMENSIONS IN MILLIMETERS.**

**Device Selection Guide****Red**

<b>Part Number</b>	<b>Min. Iv (mcd)</b>	<b>Typ. Iv (mcd)</b>	<b>Max. Iv (mcd)</b>	<b>Test Current (mA)</b>	<b>Dice Technology</b>
HSMS-A100-J00J1	4.0	15.0	-	20	GaP
HSMS-A100-L00J1	10.0	15.0	-	20	GaP
HSMS-A100-H70J2	3.0	-	8.0	10	GaP
HSMS-A100-J80J2	5.0	-	15.5	10	GaP
HSMH-A100-L00J1	10.0	15.0	-	20	AlGaAs
HSMH-A100-N00J1	25.0	50.0	-	20	AlGaAs
HSMH-A100-L70J2	12.5	-	32.0	10	AlGaAs
HSMH-A100-M80J2	20.0	-	62.0	10	AlGaAs
HSMH-A100-P30J1	40.0	-	100.0	20	AlGaAs
HSMC-A100-J00J1	4.0	100.0	-	20	AllnGaP
HSMC-A100-Q00J1	63.0	100.0	-	20	AllnGaP
HSMC-A100-R00J1	100.0	140.0	-	20	AllnGaP
HSMC-A101-S00J1	160.0	220.0	-	20	AllnGaP
HSMZ-A100-T00J1	250.0	350.0	-	20	AllnGaP
HSMC-A100-P30J1	40.0	-	100.0	20	AllnGaP
HSMC-A100-Q40J1	63.0	-	200.0	20	AllnGaP
HSMC-A101-R80J1	125.0	-	395.0	20	AllnGaP
HSMZ-A100-S80J1	200.0	-	620.0	20	AllnGaP

**Red Orange**

<b>Part Number</b>	<b>Min. Iv (mcd)</b>	<b>Typ. Iv (mcd)</b>	<b>Max. Iv (mcd)</b>	<b>Test Current (mA)</b>	<b>Dice Technology</b>
HSMJ-A100-Q00J1	63.0	100.0	-	20	AllnGaP
HSMJ-A101-S00J1	160.0	200.0	-	20	AllnGaP
HSMV-A100-T00J1	250.0	350.0	-	20	AllnGaP
HSMJ-A100-Q30J1	63.0	-	155.0	20	AllnGaP
HSMJ-A100-R40J1	100.0	-	315.0	20	AllnGaP
HSMJ-A101-R80J1	125.0	-	395.0	20	AllnGaP
HSMV-A100-S80J1	200.0	-	620.0	20	AllnGaP

**Orange**

<b>Part Number</b>	<b>Min. Iv (mcd)</b>	<b>Typ. Iv (mcd)</b>	<b>Max. Iv (mcd)</b>	<b>Test Current (mA)</b>	<b>Dice Technology</b>
HSMD-A100-J00J1	4.0	15.0	-	20	GaP
HSMD-A100-L00J1	10.0	15.0	-	20	GaP
HSMD-A100-J7PJ2	5.0	-	12.5	10	GaP
HSMD-A100-K4PJ2	6.3	-	20.0	10	GaP
HSML-A100-Q00J1	63.0	100.0	-	20	AllnGaP
HSML-A101-S00J1	160.0	220.0	-	20	AllnGaP
HSML-A100-Q7PJ1	80.0	-	200.0	20	AllnGaP
HSML-A100-R7PJ1	125.0	-	315.0	20	AllnGaP
HSML-A101-R8WJ1	125.0	-	395.0	20	AllnGaP

**Device Selection Guide, continued****Yellow/Amber**

<b>Part Number</b>	<b>Min. Iv (mcd)</b>	<b>Typ. Iv (mcd)</b>	<b>Max. Iv (mcd)</b>	<b>Test Current (mA)</b>	<b>Dice Technology</b>
HSMY-A100-J00J1	4.0	12.0	-	20	GaP
HSMY-A100-L00J1	10.0	12.0	-	20	GaP
HSMY-A100-J35J2	4.0	-	10.0	10	GaP
HSMY-A100-K45J2	6.3	-	20.0	10	GaP
HSMA-A100-Q00J1	63.0	100.0	-	20	AllnGaP
HSMA-A101-S00J1	160.0	220.0	-	20	AllnGaP
HSMU-A100-S00J1	160.0	320.0	-	20	AllnGaP
HSMA-A100-Q35J1	63.0	-	155.0	20	AllnGaP
HSMA-A100-R45J1	100.0	-	315.0	20	AllnGaP
HSMA-A101-R8WJ1	125.0	-	395.0	20	AllnGaP
HSMU-A100-S4WJ1	160.0	-	500.0	20	AllnGaP

**Yellow Green**

<b>Part Number</b>	<b>Min. Iv (mcd)</b>	<b>Typ. Iv (mcd)</b>	<b>Max. Iv (mcd)</b>	<b>Test Current (mA)</b>	<b>Dice Technology</b>
HSMG-A100-J02J1	4.0	18.0	-	20	GaP
HSMG-A100-K72J2	8.0	-	20.0	10	GaP
HSME-A100-M02J1	16.0	70.0	-	20	AllnGaP
HSME-A100-N82J1	30.0	-	100.0	20	AllnGaP

**Emerald Green**

<b>Part Number</b>	<b>Min. Iv (mcd)</b>	<b>Typ. Iv (mcd)</b>	<b>Max. Iv (mcd)</b>	<b>Test Current (mA)</b>	<b>Dice Technology</b>
HSMG-A100-H01J1	2.5	8.0	-	20	GaP
HSMG-A100-G31J2	1.6	-	4.0	10	GaP
HSMG-A100-H41J2	2.5	-	8.0	10	GaP
HSME-A100-L01J1	10.0	40.0	-	20	AllnGaP
HSME-A100-M3PJ1	16.0	-	40.0	20	AllnGaP

**Green**

<b>Part Number</b>	<b>Min. Iv (mcd)</b>	<b>Typ. Iv (mcd)</b>	<b>Max. Iv (mcd)</b>	<b>Test Current (mA)</b>	<b>Dice Technology</b>
HSMM-A101-R00J1	100.0	200.0	-	20	InGaN
HSMM-A100-S00J1	160.0	350.0	-	20	InGaN
HSMM-A101-Q7PJ1	80.0	-	200.0	20	InGaN
HSMM-A101-R7PJ1	125.0	-	315.0	20	InGaN
HSMM-A101-R8PJ1	125.0	-	395.0	20	InGaN
HSMM-A100-S8PJ1	200.0	-	620.0	20	InGaN

**Device Selection Guide, continued****Cyan**

<b>Part Number</b>	<b>Min. I<sub>v</sub> (mcd)</b>	<b>Typ. I<sub>v</sub> (mcd)</b>	<b>Max. I<sub>v</sub> (mcd)</b>	<b>Test Current (mA)</b>	<b>Dice Technology</b>
HSMK-A101-R00J1	100.0	170.0	-	20	InGaN
HSMK-A100-S00J1	160.0	280.0	-	20	InGaN
HSMK-A100-S8WJ1	200.0	-	620.0	20	InGaN
HSMK-A101-Q3WJ1	63.0	-	155.0	20	InGaN
HSMK-A101-R4WJ1	100.0	-	315.0	20	InGaN

**Blue**

<b>Part Number</b>	<b>Min. I<sub>v</sub> (mcd)</b>	<b>Typ. I<sub>v</sub> (mcd)</b>	<b>Max. I<sub>v</sub> (mcd)</b>	<b>Test Current (mA)</b>	<b>Dice Technology</b>
H SMB-A100-J00J1	4.0	15.0	-	20	GaN
H SMB-A100-J70J2	5.0	-	12.5	10	GaN
H SMB-A100-K80J2	8.0	-	25.0	10	GaN
H SMN-A101-N00J1	25.0	50.0	-	20	InGaN
H SMN-A100-P00J1	40.0	70.0	-	20	InGaN
H SMN-A101-N7YJ1	30.0	-	80.0	20	InGaN
H SMN-A101-N8YJ1	30.0	-	100.0	20	InGaN
H SMN-A100-P8YJ1	50.0	-	155.0	20	InGaN

**Note:**

1. The luminous intensity, I<sub>v</sub>, is measured at the mechanical axis of the lamp package. The actual peak of the spatial radiation pattern may not be aligned with this axis.

## Part Numbering System

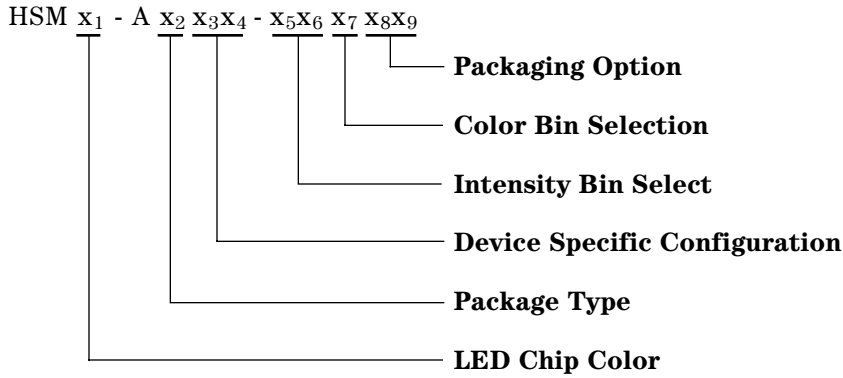

## Absolute Maximum Ratings (T<sub>A</sub> = 25°C)

Parameters	HSMS/D/Y/G	HSMH	HSMC/J/L/A	HSME	HSMZ/V/U	HSMM/K/B/N
DC Forward Current <sup>[1]</sup>	30 mA	30 mA	30 mA <sup>[3,4]</sup>	20 mA <sup>[3,4]</sup>	30 mA <sup>[3,4]</sup>	30 mA
Peak Forward Current <sup>[2]</sup>	100 mA	100 mA	100 mA	100 mA	100 mA	100 mA
Power Dissipation	63 mW	60 mW	63 mW	48 mW	72 mW	114 mW
Reverse Voltage	5 V					
Junction Temperature	110°C					
Operating Temperature	-55°C to +100°C					
Storage Temperature	-55°C to +100°C					

### Notes:

1. Derate linearly as shown in Figure 4.
2. Duty factor = 10%, Frequency = 1 kHz.
3. Drive current between 10 mA and 30 mA is recommended for best long term performance.
4. Operation at current below 5 mA is not recommended.

### Optical Characteristics (T<sub>A</sub> = 25°C)

Color	Part Number	Dice Technology	Peak Wavelength	Dominant Wavelength <sup>[1]</sup>	Viewing Angle	Luminous Efficacy $\eta_v$ <sup>[3]</sup>	Luminous Intensity/ Total Flux
			$\lambda_{PEAK}$ (nm) Typ.	$\lambda_D$ (nm) Typ.	$2 \theta_{1/2}$ <sup>[2]</sup> (Degrees) Typ.	(lm/W) Typ.	$I_v(mcd)/\Phi_v(mlm)$ Typ.
Red	HSMS-A100	GaP	635	626	120	120	0.45
	HSMH-A100	AlGaAs	645	637	120	63	0.45
	HSMC-A10x	AllnGaP	635	626	120	150	0.45
	HSMZ-A100	AllnGaP	639	630	120	155	0.45
Red Orange	HSMJ-A10x	AllnGaP	621	615	120	240	0.45
	HSMV-A100	AllnGaP	623	617	120	263	0.45
Orange	HSMD-A100	GaP	600	602	120	380	0.45
	HSM L-A10x	AllnGaP	609	605	120	320	0.45
Amber	HSMY-A100	GaP	583	585	120	520	0.45
	H SMA-A10x	AllnGaP	592	590	120	480	0.45
	HSMU-A100	AllnGaP	594	592	120	500	0.45
Yellow Green	HSMG-A100	GaP	565	569	120	590	0.45
	HSM E-A100	AllnGaP	575	570	120	560	0.45
Emerald Green	HSMG-A100	GaP	558	560	120	650	0.45
	HSM E-A100	AllnGaP	566	560	120	610	0.45
Green	HSMM-A10x	InGaN	523	525	120	500	0.45
Cyan	HSMK-A10x	InGaN	502	505	120	300	0.45
Blue	HSMB-A100	GaN	428	462	120	65	0.45
	HSMN-A10x	InGaN	468	470	120	75	0.45

#### Notes:

1. The dominant wavelength,  $\lambda_D$ , is derived from the CIE Chromaticity Diagram and represents the color of the device.
2.  $\theta_{1/2}$  is the off-axis angle where the luminous intensity is 1/2 the peak intensity.
3. Radiant intensity,  $I_e$  in watts/steradian, may be calculated from the equation  $I_e = I_v/\eta_v$ , where  $I_v$  is the luminous intensity in candelas and  $\eta_v$  is the luminous efficacy in lumens/watt.

### Electrical Characteristics (T<sub>A</sub> = 25°C)

Part Number	Forward Voltage V <sub>F</sub> (Volts) @ I <sub>F</sub> = 20 mA		Reverse Voltage V <sub>R</sub> @ 100 $\mu$ A	Reverse Voltage V <sub>R</sub> @ 10 $\mu$ A	Thermal Resistance R $\theta_{JP}$ (°C/W)
	Typ.	Max.	Min.	Min.	
HSMS/D/Y/G	2.2	2.6	5	—	180
HSMH	1.9	2.6	5	—	180
HSMC/J/L/A/E	1.9	2.4	5	—	280
HSMZ/V/U	2.2	2.6	5	—	280
HSMB	3.9	4.3	—	5	280
HSMM/K/N	3.4	4.05	—	5	280

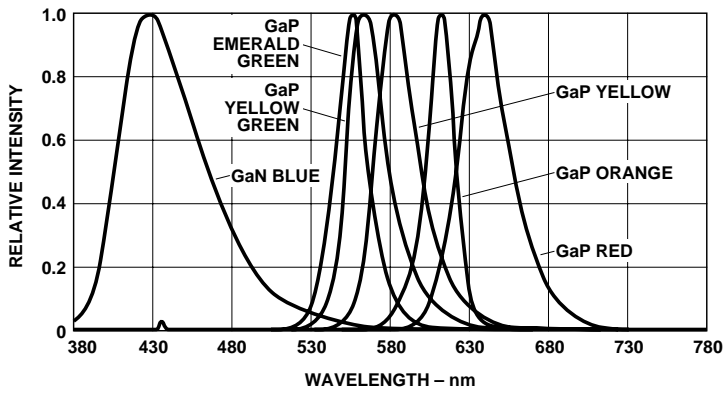
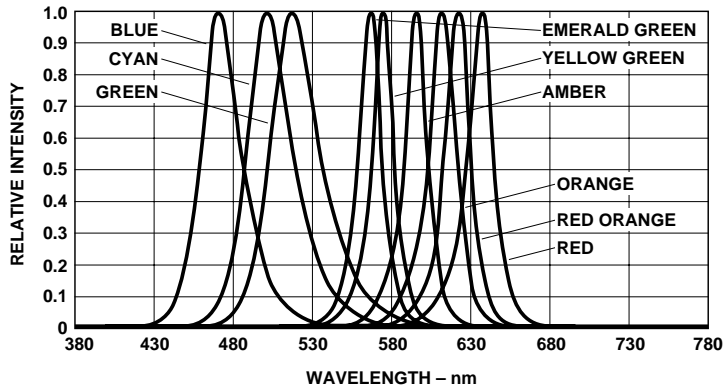

Figure 1. Relative intensity vs. wavelength.

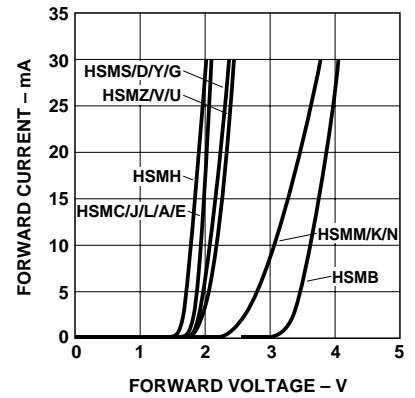

Figure 3. Relative intensity vs. forward current.

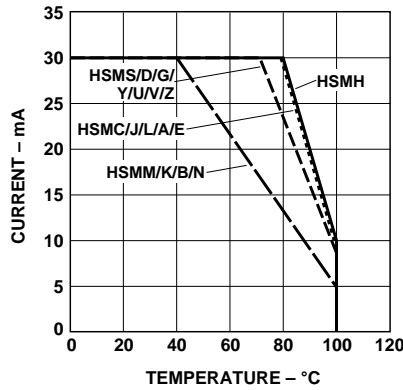

Figure 4. Maximum forward current vs. ambient temperature. Derated based on  $T_{JMAX} = 110^{\circ}C$ ,  $R_{\theta JA} = 500^{\circ}C/W$ .

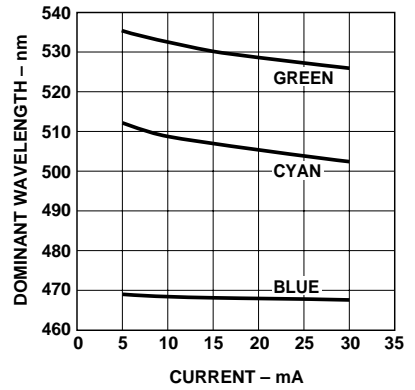

Figure 5. Dominant wavelength vs. forward current – InGaN devices.



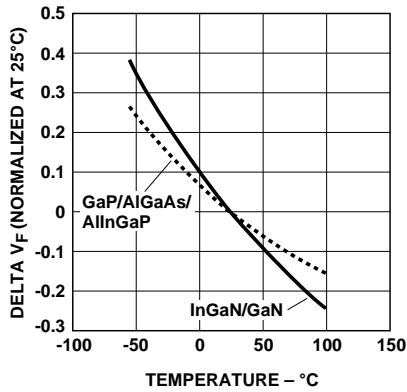

Figure 6. Forward voltage shift vs. temperature.

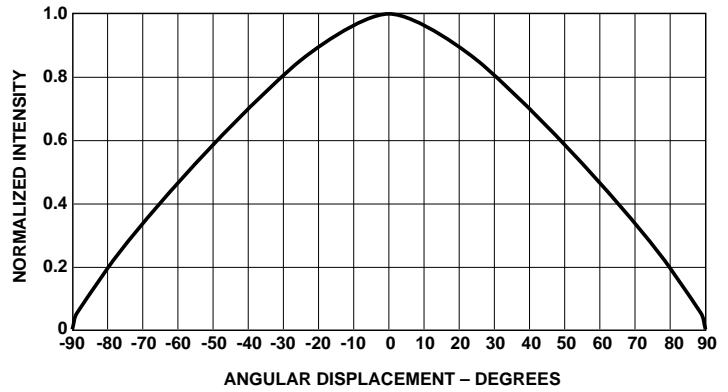

Figure 7. Radiation Pattern.

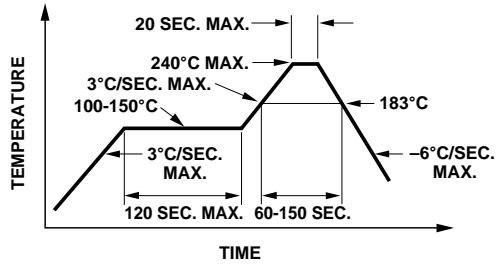
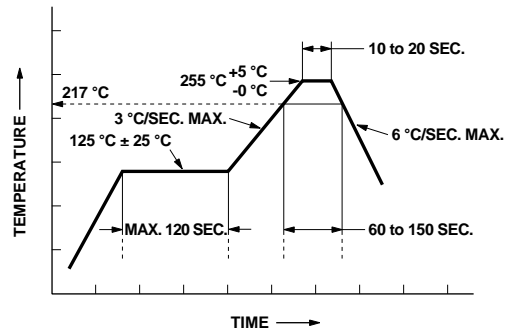
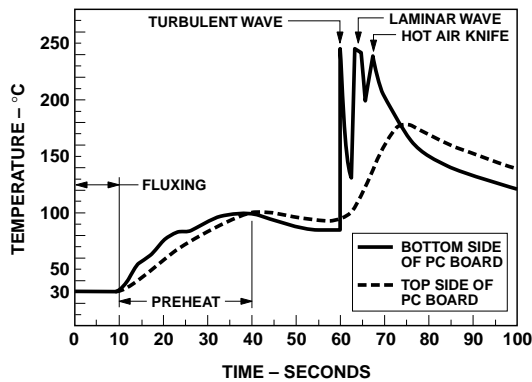

Figure 8a. Recommended SnPb reflow soldering profile.



\* THE TIME FROM 25 °C TO PEAK TEMPERATURE = 6 MINUTES MAX.

Figure 8b. Recommended Pb-free reflow soldering profile.



CONVEYOR SPEED = 1.83 M/MIN (6 FT/MIN)  
 PREHEAT SETTING = 150°C (100°C PCB)  
 SOLDER WAVE TEMPERATURE = 245°C  
 AIR KNIFE AIR TEMPERATURE = 390°C  
 AIR KNIFE DISTANCE = 1.91 mm (0.25 IN.)  
 AIR KNIFE ANGLE = 40°  
 SOLDER: SN63; FLUX: RMA

NOTE: ALLOW FOR BOARDS TO BE SUFFICIENTLY COOLED BEFORE EXERTING MECHANICAL FORCE.

Figure 9. Recommended wave soldering profile.

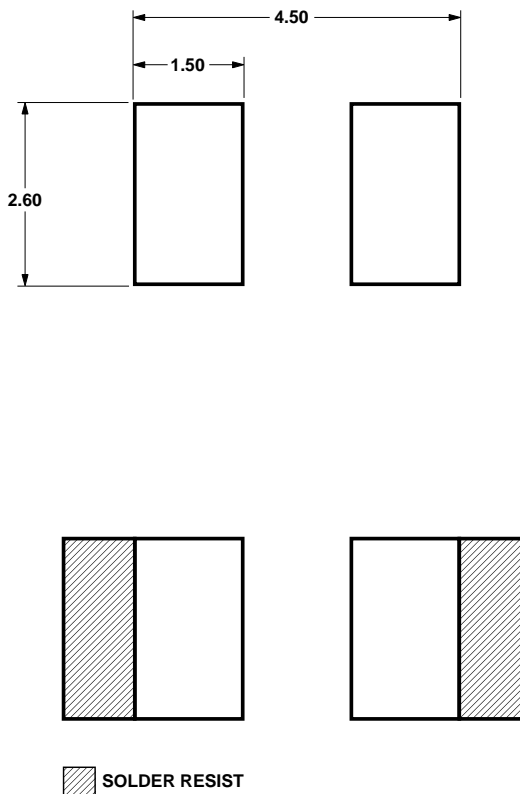

Figure 10. Recommended soldering pad pattern.

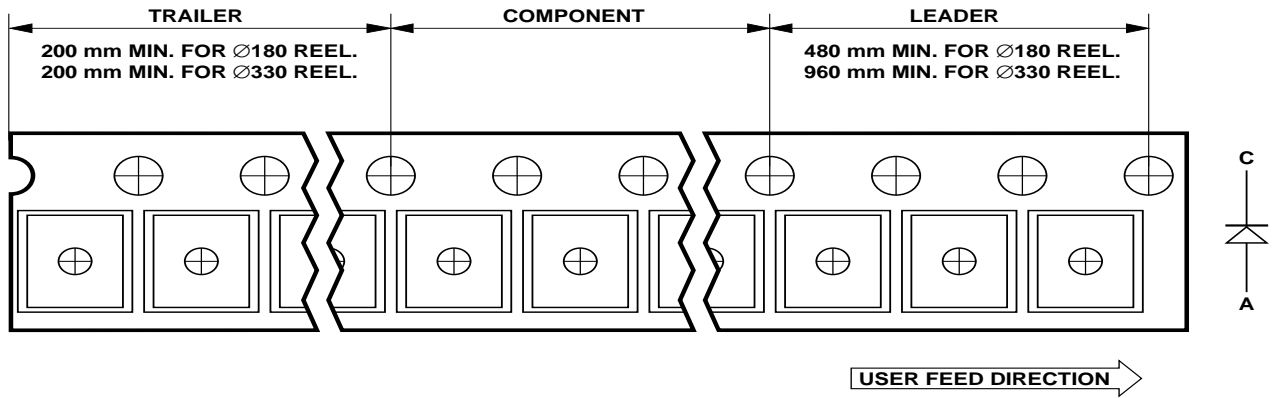

Figure 11. Tape leader and trailer dimensions.

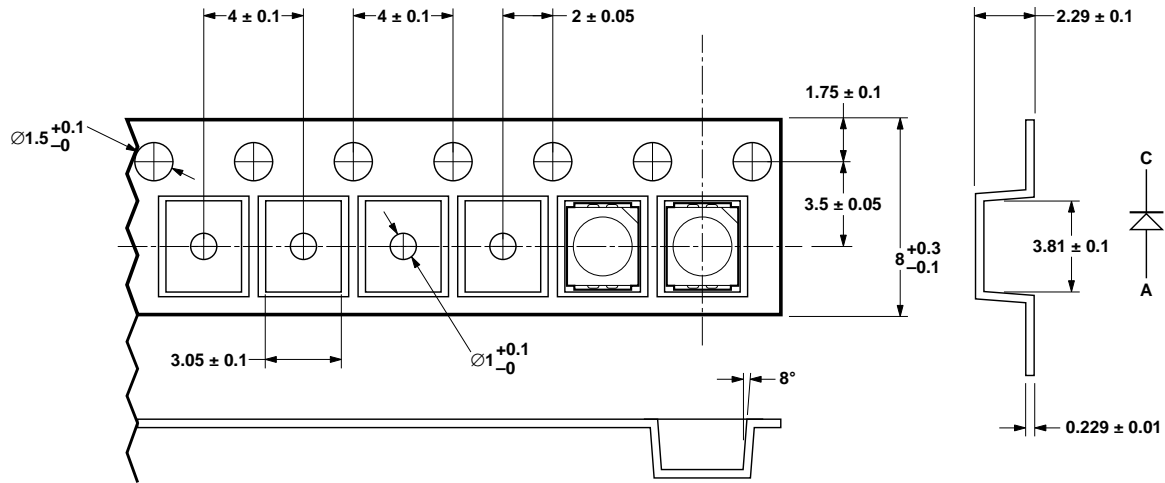

Figure 12. Tape dimensions.

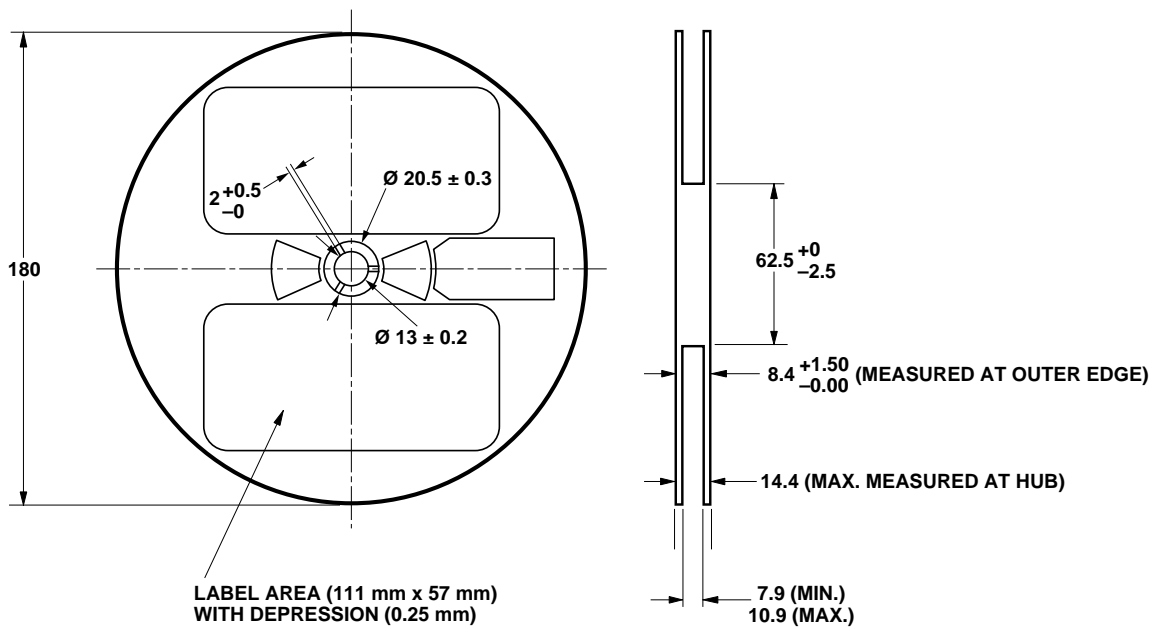

Figure 13. Reel dimensions.

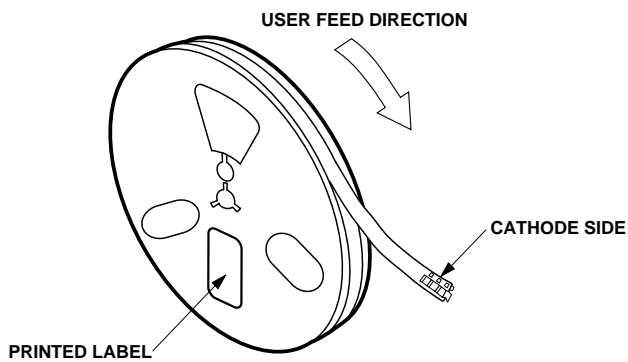

Figure 14. Reeling orientation.

Baking is required under the following conditions:

- a) the humidity indicator turns pink
- b) the pack has been opened for more than four weeks.

Baking recommended condition:  
 $60 \pm 5^\circ\text{C}$  for 20 hours.

This product is qualified as Moisture Sensitive JEDEC Level 2A.

**Intensity Bin Select (X<sub>5</sub>X<sub>6</sub>)**

Individual reel will contain parts from one half bin only.

X <sub>5</sub>	Min I <sub>v</sub> Bin
X <sub>6</sub>	
0	Full Distribution
3	3 half bins starting from X <sub>5</sub> 1
4	4 half bins starting from X <sub>5</sub> 1
5	5 half bins starting from X <sub>5</sub> 1
7	3 half bins starting from X <sub>5</sub> 2
8	4 half bins starting from X <sub>5</sub> 2
9	5 half bins starting from X <sub>5</sub> 2

**Intensity Bin Limits**

Bin ID	Min. (mcd)	Max. (mcd)
G1	1.80	2.24
G2	2.24	2.80
H1	2.80	3.55
H2	3.55	4.50
J1	4.50	5.60
J2	5.60	7.20
K1	7.20	9.00
K2	9.00	11.20
L1	11.20	14.00
L2	14.00	18.00
M1	18.00	22.40
M2	22.40	28.50
N1	28.50	35.50
N2	35.50	45.00
P1	45.00	56.00
P2	56.00	71.50
Q1	71.50	90.00
Q2	90.00	112.50
R1	112.50	140.00
R2	140.00	180.00
S1	180.00	224.00
S2	224.00	285.00
T1	285.00	355.00
T2	355.00	450.00
U1	450.00	560.00
U2	560.00	715.00
V1	715.00	900.00
V2	900.00	1125.00

Tolerance of each bin limit = ± 12%.

**Color Bin Select (X<sub>7</sub>)**

Individual reel will contain parts from one full bin only.

X <sub>7</sub>	
0	Full Distribution
Z	A and B only
Y	B and C only
W	C and D only
V	D and E only
U	E and F only
T	F and G only
S	G and H only
Q	A, B, and C only
P	B, C, and D only
N	C, D, and E only
M	D, E, and F only
L	E, F, and G only
K	F, G, and H only
1	A, B, C, and D only
2	E, F, G, and H only
3	B, C, D, and E only
4	C, D, E, and F only
5	A, B, C, D, and E only
6	B, C, D, E, and F only

**Color Bin Limits**

Blue	Min. (nm)	Max. (nm)
A	460.0	465.0
B	465.0	470.0
C	470.0	475.0
D	475.0	480.0

Cyan	Min. (nm)	Max. (nm)
A	490.0	495.0
B	495.0	500.0
C	500.0	505.0
D	505.0	510.0

Green	Min. (nm)	Max. (nm)
A	515.0	520.0
B	520.0	525.0
C	525.0	530.0
D	530.0	535.0

**Color Bin Limits**

Emerald Green	Min. (nm)	Max. (nm)
A	552.5	555.5
B	555.5	558.5
C	558.5	561.5
D	561.5	564.5

Yellow Green	Min. (nm)	Max. (nm)
E	564.5	567.5
F	567.5	570.5
G	570.5	573.5
H	573.5	576.5

Amber	Min. (nm)	Max. (nm)
A	582.0	584.5
B	584.5	587.0
C	587.0	589.5
D	589.5	592.0
E	592.0	594.5
F	594.5	597.0

Orange	Min. (nm)	Max. (nm)
A	597.0	600.0
B	600.0	603.0
C	603.0	606.0
D	606.0	609.0
E	609.0	612.0

Red Orange	Min. (nm)	Max. (nm)
A	611.0	616.0
B	616.0	620.0

Red	Min. (nm)	Max. (nm)
-----	-----------	-----------

Full Distribution

Tolerance of each bin limit = ± 1 nm.

### Packaging Option (X<sub>8</sub>X<sub>9</sub>)

Option	Test Current	Package Type	Reel Size
J1	20 mA	Top Mount	7 inch
J4	20 mA	Top Mount	13 inch
H1	20 mA	Reverse Mount	7 inch
H4	20 mA	Reverse Mount	13 inch
J2	10 mA	Top Mount	7 inch
J5	10 mA	Top Mount	13 inch
H2	10 mA	Reverse Mount	7 inch
H5	10 mA	Reverse Mount	13 inch

### [www.agilent.com/semiconductors](http://www.agilent.com/semiconductors)

For product information and a complete list of distributors, please go to our web site.

For technical assistance call:

Americas/Canada: +1 (800) 235-0312 or  
(916) 788-6763

Europe: +49 (0) 6441 92460

China: 10800 650 0017

Hong Kong: (+65) 6756 2394

India, Australia, New Zealand: (+65) 6755 1939

Japan: (+81 3) 3335-8152 (Domestic/International), or 0120-61-1280 (Domestic Only)

Korea: (+65) 6755 1989

Singapore, Malaysia, Vietnam, Thailand,  
Philippines, Indonesia: (+65) 6755 2044

Taiwan: (+65) 6755 1843

Data subject to change.

Copyright © 2004-2005 Agilent Technologies, Inc.

Obsoletes 5989-1207EN

May 15, 2005

5989-3100EN

