

Silicon PIN Limiter Diodes

MA4L Series V 5.0

5

Features

- Lower Insertion Loss and Noise Figure
- Higher Peak and Average Operating Power
- Various P1dB Compression Powers
- Lower Flat Leakage Power
- Reliable Silicon Nitride Passivation

Description

M/A-COM produces a series of small and medium I-region length silicon PIN diodes specifically designed for high signal limiter applications. Each of these devices provides circuit designers with lower insertion loss at zero bias, faster response and recovery times, and lower flat leakage power. This series of diode is available as passivated chips (ODS 132 or ODS 134) as well as hermetic surface mount and cylindrical ceramic packages. Consult factory for specific package style availability.

Applications

The MA4L Series of PIN limiter diodes are designed for use in passive limiter control circuits to protect sensitive receiver components such as low noise amplifiers (LNA), detectors, and mixers covering the 10MHz to 18GHz frequency band.

Absolute Maximum Ratings¹

@ T_A = +25°C (Unless otherwise specified)

Parameter	Absolute Maximum
Forward Current	100 mA
Operating Temperature	-55°C to +125°C
Storage Temperature	-55°C to +150°C
Junction Temperature	+175°C
RF Peak Incident Power	Per Performance Table
RF C.W. Incident Power	Per Performance Table
Mounting Temperature	+320°C for 10 sec.

Notes:

1. Exceeding these limits may cause permanent damage.

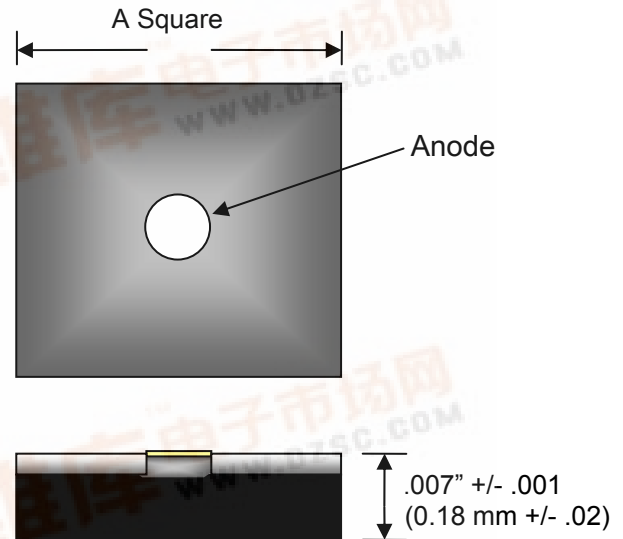

ODS	Dimension	Mils	mm
134	A	13 +/- 2.0	0.33 +/- 0.05
132	A	20 +/- 2.0	0.51 +/- 0.05

Un-Packaged Die Electrical Specifications at +25°C

Part Number	Minimum Reverse Voltage V_R	Maximum Reverse Voltage V_R	Minimum C_{j0V} pF	Maximum C_{j0V} pF	Maximum ¹ $R_{S\ 10mA}$ Ohms	Nominal Characteristics			
						Carrier Lifetime @ 10mA nS	I-Region Thickness μM	Contact Diameter mils	Thermal ² Resistance $^{\circ}C/W$
MA4L011-134	20	35	0.13	0.20	2.00	15	2	1.00	200
MA4L021-134	20	35	0.13	0.20	2.00	15	2	1.00	200
MA4L022-134	20	35	0.13	0.20	2.00	15	2	1.00	200
MA4L031-134	30	50	0.13	0.20	2.50	20	3	1.50	150
MA4L032-134	30	50	0.13	0.20	2.50	20	3	1.50	150
MA4L062-134	65	75	0.07	0.15	2.50	15	4	1.50	150
MA4L101-134	100			0.15	2.00	90	13	3.50	30
MA4L401-132	250			0.30	1.20	800	25	4.50	25

Nominal High Signal Performance @ +25°C

Part Number	Incident ³ Peak Power For 1dB Limiting @ 9.4GHz dBm	Incident ³ Peak Power For 10dB Limiting @ 9.4GHz dBm	Incident ³ Peak Power For 20dB Limiting @ 9.4GHz dBm	Recovery ³ Time, (3dB) @ 50W Peak Power nS	Maximum ³ Incident Peak Power Watts	Maximum ⁴ CW Input Power Watts
MA4L011-134	7	25	40	10	100	2
MA4L021-134	10	30	43	10	400	4
MA4L022-134	10	30	43	10	200	3
MA4L031-134	16	36	49	20	800	5
MA4L032-134	16	36	49	20	600	3
MA4L062-134	16	36	49	20	600	5
MA4L101-134	19	42	52	10	900	4
MA4L401-132	29	52	65	100	2000	10

Notes for Specifications and Nominal High Signal Performance Table:

1. **Maximum Series Resistance** - R_S , is measured at 500MHz in the ODS-30 package and is equivalent to the total diode resistance : $R_S = R_j$ (Junction Resistance) + R_c (Ohmic Resistance)
2. **Nominal C.W. Thermal Resistance** - θ_{TH} is measured in ceramic pill package, ODS-30, mounted to a metal (infinite) heatsink. Diode only thermal resistance values are approximately 2 °C/W lower in value than the ODS-30 listed package values.
3. **Maximum High Signal Performance** – Measured using a single shunt diode (die) attached directly to the gold plated RF housing ground with 2 mil thick conductive silver epoxy in a 50Ω, SMA, connectorized test fixture. Chip anode contact is thermo sonically wire bonded using a 1 mil dia. gold wire onto a 7.2 mil thick Rogers 5880 duroid microstrip trace. A shunt coil provides the D.C. return. Test Frequency = 9.4 GHz, RF pulse width = 1.0 μS, 0.001 duty cycle.
4. **Maximum C.W Incident Power** - Measured in a 50 Ω, SMA, connectorized housing @ 4GHz utilizing a TWT amplifier and the same single diode assembly configuration as stated in Note 3 above.

Die Handling and Mounting Information

Handling: All semiconductor chips should be handled with care in order to avoid damage or contamination from perspiration, salts, and skin oils. For individual die, the use of plastic tipped tweezers or vacuum pick up tools is strongly recommended. Bulk handling should ensure that abrasion and mechanical shock are minimized.

Die Attach: The die have Ti-Pt-Au back and anode metal, with a final gold thickness of 1.0 μm. Die can be mounted with a gold-tin, eutectic solder preform or conductive silver epoxy. The metal RF and D.C. ground plane mounting surface must be free of contamination and should have a surface flatness of < +/- 0.002“.

Eutectic Die Attachment Using Hot Gas Die Bouncer: An 80/20, gold-tin eutectic solder preform is recommended with a work surface temperature of 255°C and a tool tip temperature of 220°C. When the hot gas is applied, the temperature at the tool tip should be approximately 290°C. The chip should not be exposed to temperatures greater than 320°C for more than 10 seconds.

Eutectic Die Attachment Using Reflow Oven: See Application Note M541, “Bonding and Handling Procedures for Chip Diode Devices” at www.macom.com. for recommended profile.

Epoxy Die Attachment: A thin, controlled amount of electrically conductive silver epoxy should be applied at approximately a 1–2 mils thickness to minimize ohmic and thermal resistances. A thin epoxy fillet should be visible around the perimeter of the chip after placement to ensure full area coverage. Cure conductive epoxy per manufacturer’s schedule.

Die Bonding: The anode bond pads on these die have a Ti-Pt-Au metallization scheme, with a final gold thickness of 1.0 μm. Thermosonic wedge wire bonding of 0.001” diameter gold wire is recommended with a stage temperature of 150°C and a force of 18 to 40 grams. Ultrasonic energy should be adjusted to the minimum required. Automatic ball bonding can also be used.

See Application Note M541, “Bonding and Handling Procedures for Chip Diode Devices” for more detailed handling and assembly instructions at www.macom.com.

Specification Subject to Change Without Notice

Typical High Signal Peak Power Performance for the Single Shunt Limiter Diode
in a 50Ω Test Fixture (Note 3)

Typical Peak Power Performance for Single Shunt Limiter Diode in 50 Ohm System
at 9.4 GHz, 1uS Pulse Width, 0.001 Duty

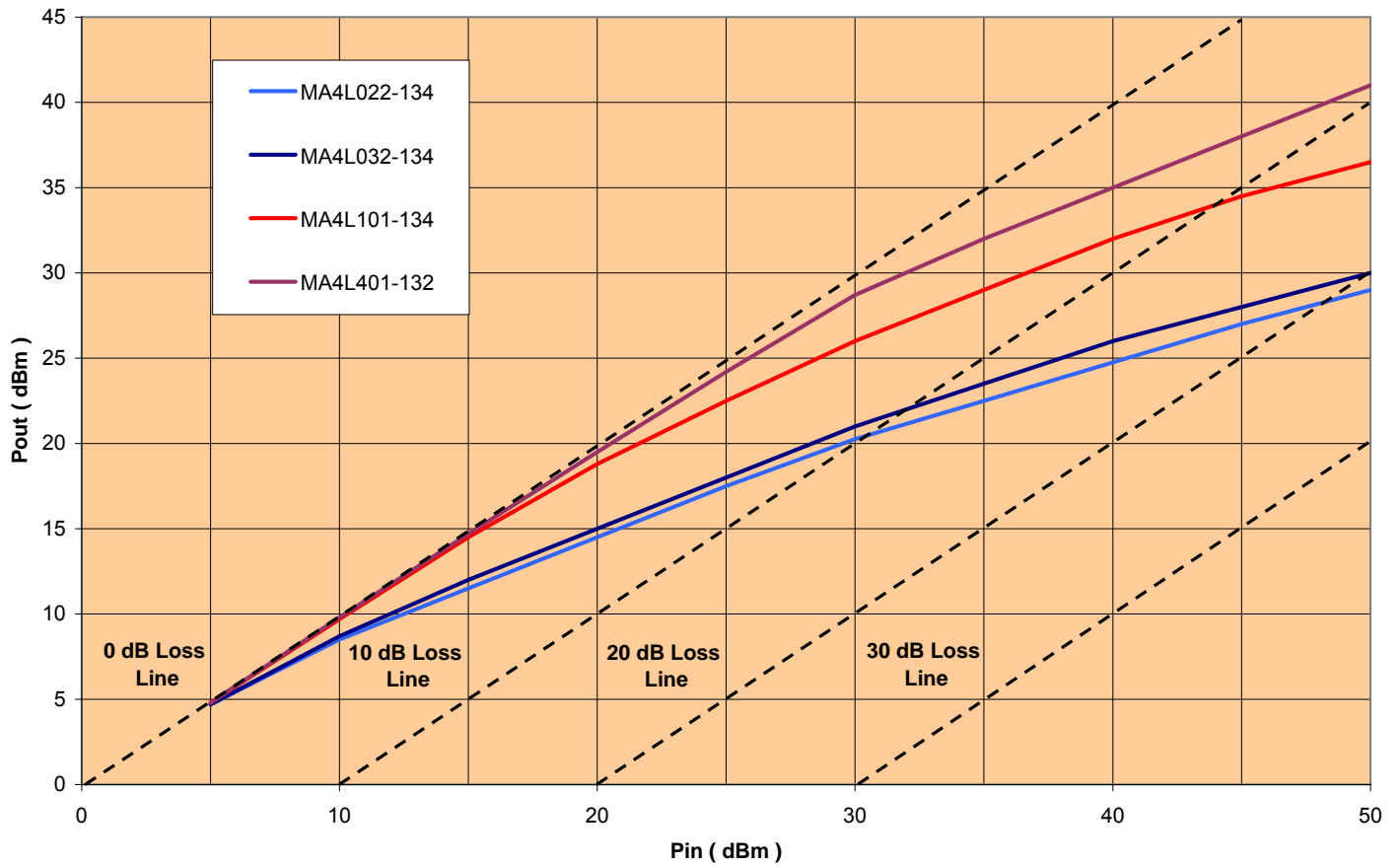

Application Circuits

Typical +60dBm Peak Power, 1 μ S P.W., 0.001% Duty Cycle, +20dBm Flat Leakage Limiter Circuit

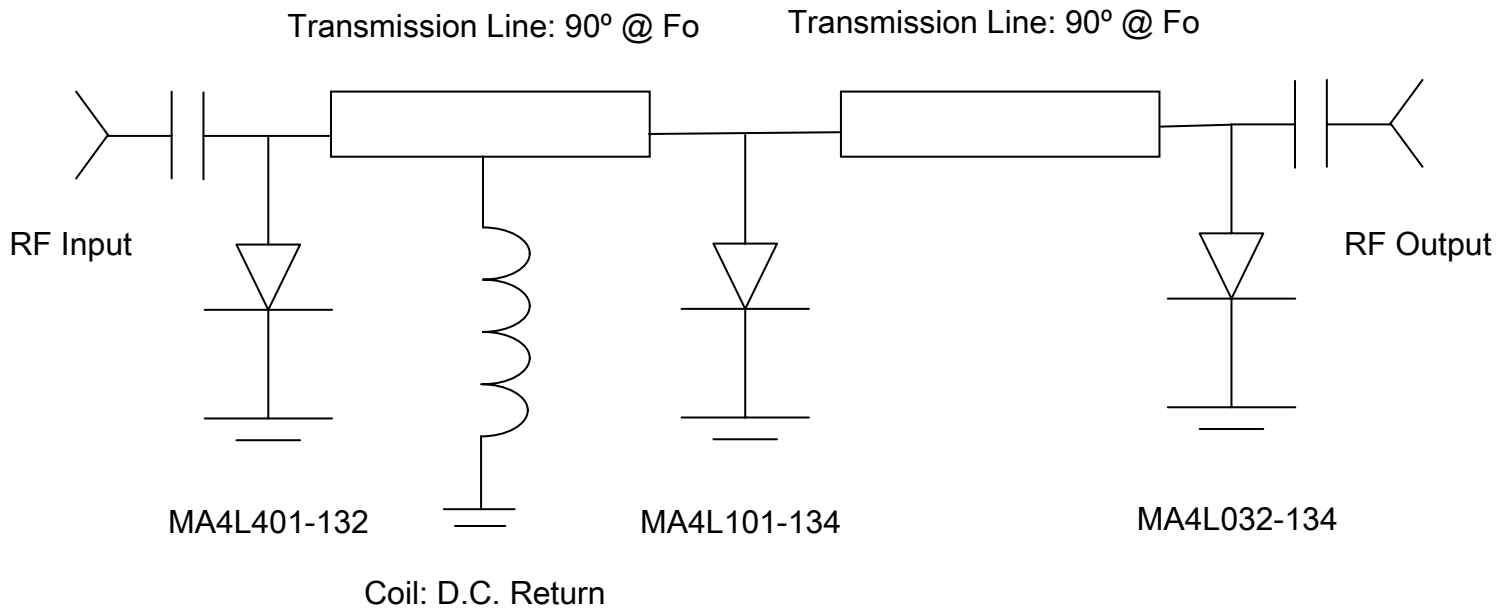

Typical +50 dBm Peak Power, 1 μ S P.W., 0.001% Duty Cycle, +20 dBm Flat Leakage Limiter Circuit

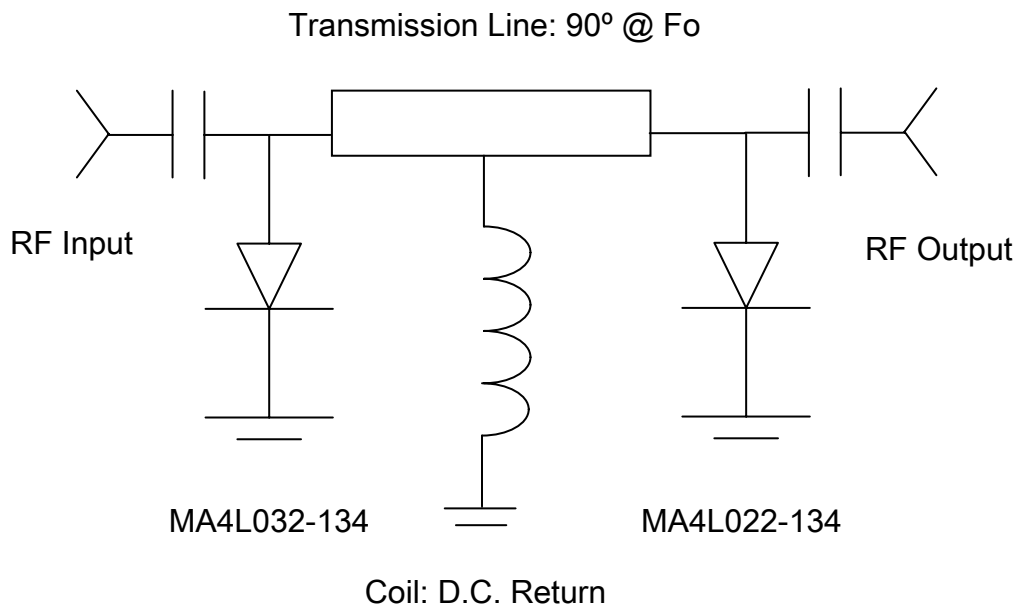

Popular Case Styles and Associated Parasitics (Table I)

Package Style	Package Type	Cpkg (pF)	Ls (nH)
30	Ceramic Pill	0.18	0.60
31	Ceramic Pill	0.18	0.60
32	Ceramic Pill	0.30	0.40
36	Ceramic Pill	0.18	0.60
137	Ceramic Surface Mount with Leads	0.14	0.70
186	Ceramic Surface Mount with Leads	0.18	0.70
1056	Ceramic Surface Mount with Wrap Around Contacts	0.20	0.70

Part Numbering and Ordering Information

1. The die only P/N's use either the -132 or -134 suffix (see Electrical Specification Table).
2. The packaged P/N's use the associated suffix as defined in Table I instead of the die number.

For example, the MA4L032-134 die in the 186 style package becomes: MA4L032-186