



SP78LXX

100mA 3-Terminal Positive Voltage Regulator

Features

- Output Current up to 100 mA
- Fixed Output Voltage of 5V and 12V
- Output Voltage Tolerances of $\pm 5\%$ over the Full Temperature Range
- Internal Short Circuit Current-Limiting
- Internal Thermal Overload Protection
- No External Components
- Available in Lead Free, RoHS Compliant Packaging

SOT-89 Package

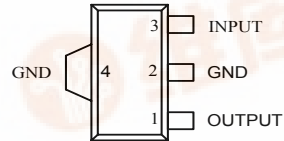

Applications

- High Efficiency Linear Regulator
- Post Regulation for Switching Supply
- Microprocessor Power Supply
- Mother Board I/O Power Supply

General Description

The SP78LXX series are three terminal positive regulators with several fixed output voltages. These regulators can provide local on-card regulation, eliminating distribution problems associated with single point regulation. The SP78LXX can be used in logic systems, instrumentation, HiFi, and other solid state electronic equipment. When used as a Zener diode/resistor combination replacement, the SP78LXX usually results an effective output impedance improvement of two orders of magnitude, and lower quiescent current.

With adequate heat sinking the SP78LXX can deliver 100 mA output current. Current limiting is included to limit the peak output current to a safe value. Thermal protection is also provided. If internal power dissipation becomes too high for the heat sinking provided, the thermal shutdown circuit takes over preventing the IC from overheating.

The SP78LXX are available in the plastic TO-92, NSOIC-8, SOT-223 and SOT-89 packages.

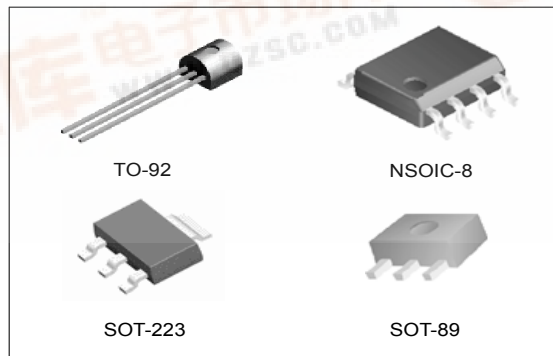

Figure 1. Package Types of the SP78LXX

Pin Configuration

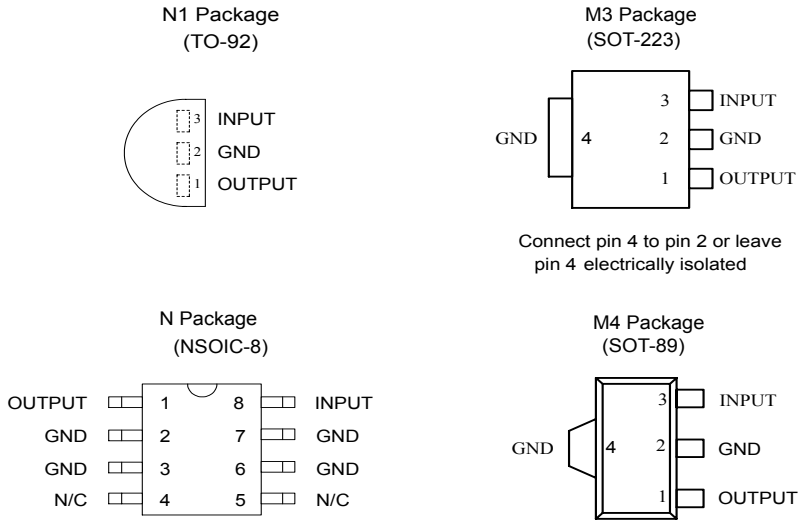

Figure 2. Pin Configuration of the SP78LXX (Top View)

Functional Block Diagram

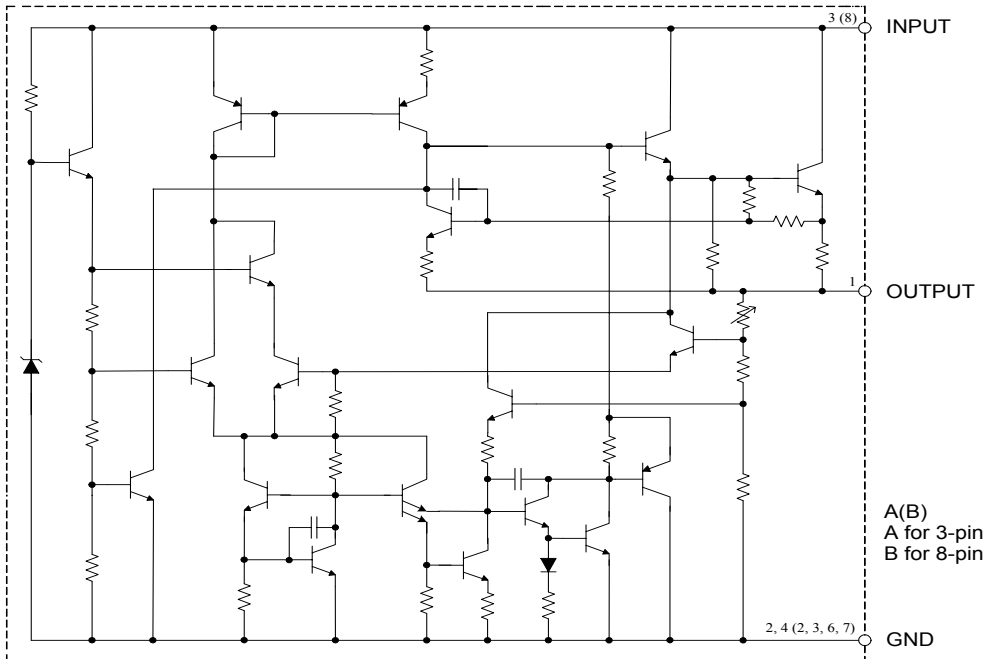

Figure 3. Functional Block Diagram of the SP78LXX

Absolute Maximum Ratings (Note 1)

Parameter	Symbol	Value	Unit	
Input Voltage	V_{CC}	20	V	
Operating Junction Temperature Range	T_J	0 to 125	°C	
Lead Temperature (Soldering, 10sec)	T_{LEAD}	265	°C	
Power Dissipation ($T_A=25^\circ\text{C}$)	P_D	TO-92	0.65	W
		NSOIC	0.6	
		SOT-223	0.7	
		SOT-89	0.65	
Storage Temperature Range	T_{STG}	-65 to 150	°C	
ESD (Machine Model)		300	V	

Note 1: Stresses greater than those listed under "Absolute Maximum Ratings" may cause permanent damage to the device. These are stress ratings only, and functional operation of the device at these or any other conditions beyond those indicated under "Recommended Operating Conditions" is not implied. Exposure to "Absolute Maximum Ratings" for extended periods may affect device reliability.

Recommended Operating Conditions

Parameter	Symbol	Min	Max	Unit
Operating Junction Temperature Range	T_J	0	125	°C

Electrical Characteristics

SP78L05 Electrical Characteristics

Limits in standard typeface are for $T_J=25^\circ\text{C}$, **Bold typeface applies over 0°C to 125°C** , $I_O=40\text{ mA}$, $C_I=0.33\mu\text{F}$, $C_O=0.1\mu\text{F}$, $V_I=10\text{V}$, unless otherwise specified.

Parameter	Symbol	Conditions	Min	Typ	Max	Unit
Output Voltage	V_O		4.8	5	5.2	V
		$7.0\text{V} \leq V_I \leq 15\text{V}$ $1.0\text{mA} \leq I_O \leq 40\text{mA}$ (Note 2)	4.75		5.25	
Line Regulation	V_{RLINE}	$7.0\text{V} \leq V_I \leq 15\text{V}$		18	75	mV
Load Regulation	V_{RLOAD}	$1.0\text{mA} \leq I_O \leq 100\text{mA}$		20	60	mV
Quiescent Current	I_Q			3	5	mA
Quiescent Current Change	ΔI_Q	$8.0\text{V} \leq V_I \leq 15\text{V}$			1.0	mA
		$1.0\text{mA} \leq I_O \leq 40\text{mA}$			0.1	
Output Noise Voltage	N_O	$10\text{Hz} \leq f \leq 100\text{kHz}$ (Note 3)		40		μV
Ripple Rejection	$\Delta V_I / \Delta V_O$	$f=120\text{Hz}$, $8.0\text{V} \leq V_I \leq 15\text{V}$	47	62		dB
Peak Output Current	I_{PK}			150		mA
Average Temperature Coefficient of Output Voltage	$\Delta V_O / \Delta T$	$I_O = 5.0\text{mA}$		-0.65		mV/°C
Minimum Value of Input Voltage Required to Maintain Line Regulation	$V_I(\text{Min})$			6.7	7	V

Note 2: Power Dissipation $\leq 0.6\text{W}$

Note 3: Recommended minimum load capacitance of $0.01\mu\text{F}$ to limit high frequency noise.

Electrical Characteristics (Continued)

SP78L12 Electrical Characteristics

Limits in standard typeface are for $T_j = 25^\circ\text{C}$, **Bold typeface applies over 0°C to 125°C** , $I_O = 40\text{ mA}$, $C_1 = 0.33\mu\text{F}$, $C_O = 0.1\mu\text{F}$, $V_1 = 18\text{V}$, unless otherwise specified.

Parameter	Symbol	Conditions	Min	Typ	Max	Unit
Output Voltage	V_O		11.5	12	12.5	V
		$15\text{V} \leq V_1 \leq 18\text{V}$ $1.0\text{mA} \leq I_O \leq 40\text{mA}$ (Note 2)	11.4		12.6	
Line Regulation	V_{RLINE}	$15\text{V} \leq V_1 \leq 18\text{V}$		18	75	mV
Load Regulation	V_{RLOAD}	$1.0\text{mA} \leq I_O \leq 100\text{mA}$		20	90	mV
Quiescent Current	I_Q			3	5	mA
Quiescent Current Change	ΔI_Q	$15\text{V} \leq V_1 \leq 18\text{V}$			1.5	mA
		$1.0\text{mA} \leq I_O \leq 40\text{mA}$			0.1	
Output Noise Voltage	N_O	$10\text{Hz} \leq f \leq 100\text{kHz}$ (Note 3)		80		μV
Ripple Rejection	$\Delta V_I / \Delta V_O$	$f = 120\text{Hz}$, $15\text{V} \leq V_1 \leq 18\text{V}$	40	54		dB
Peak Output Current	I_{PK}			150		mA
Average Temperature Coefficient of Output Voltage	$\Delta V_O / \Delta T$	$I_O = 5.0\text{mA}$		-1.0		mV/°C
Minimum Value of Input Voltage Required to Maintain Line Regulation	$V_1(\text{Min})$			13.7		V

Note 2: Power Dissipation $\leq 0.6\text{W}$

Note 3: Recommended minimum load capacitance of $0.01\mu\text{F}$ to limit high frequency noise.

Typical Performance Characteristics

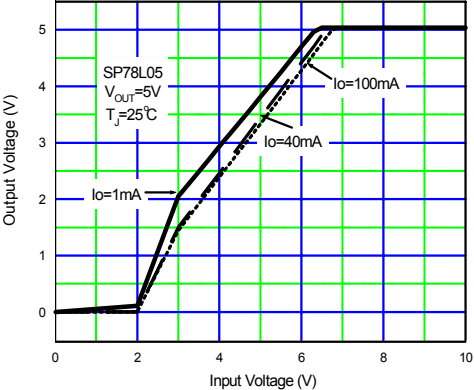

Figure 4. Dropout Characteristics

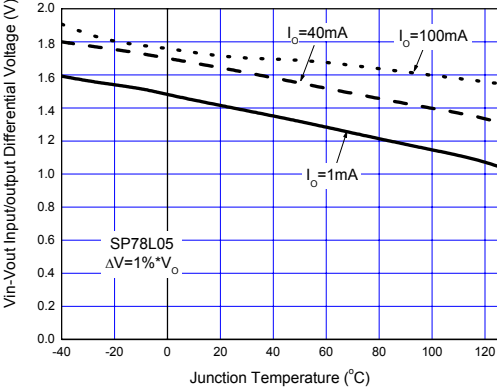

Figure 5. Dropout Voltage vs. Junction Temperature

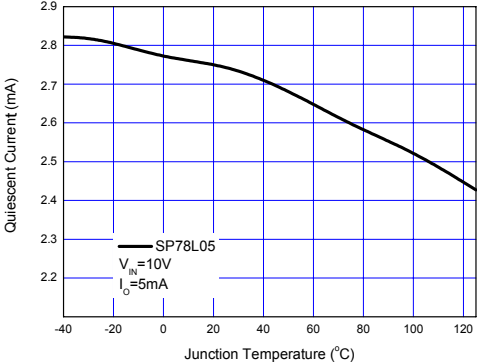

Figure 6. Quiescent Current vs. Junction Temperature

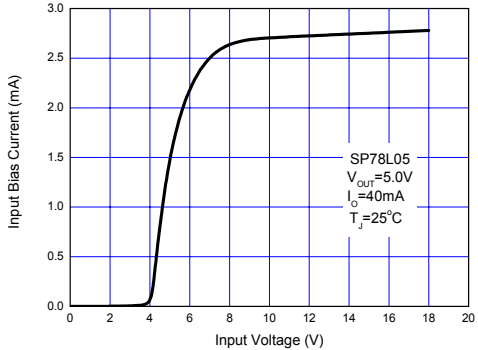

Figure 7. Input Bias Current vs. Input Voltage

Typical Performance Characteristics (Continued)

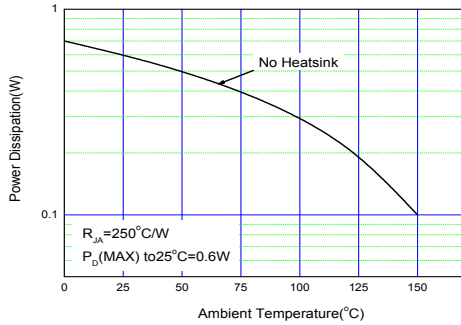

Figure 8. Maximum Power Dissipation vs. Ambient Temperature (NSOIC-8 Package)

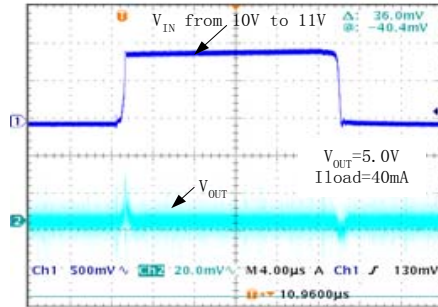

Figure 9. Line Transient Response

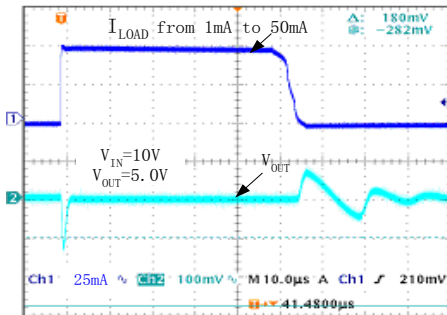
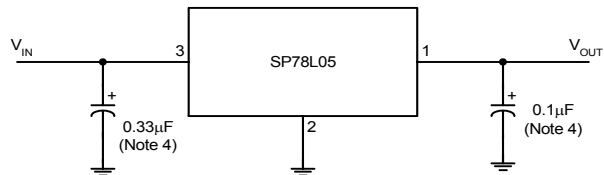

Figure 10. Load Transient Response

Typical Application



Note 4: Bypass capacitors are recommended for optimum stability and transient response and should be located as close as possible to the regulator.

Figure 11. Typical Application of the SP78LXX

Mechanical Dimensions

TO-92

Unit: mm(inch)

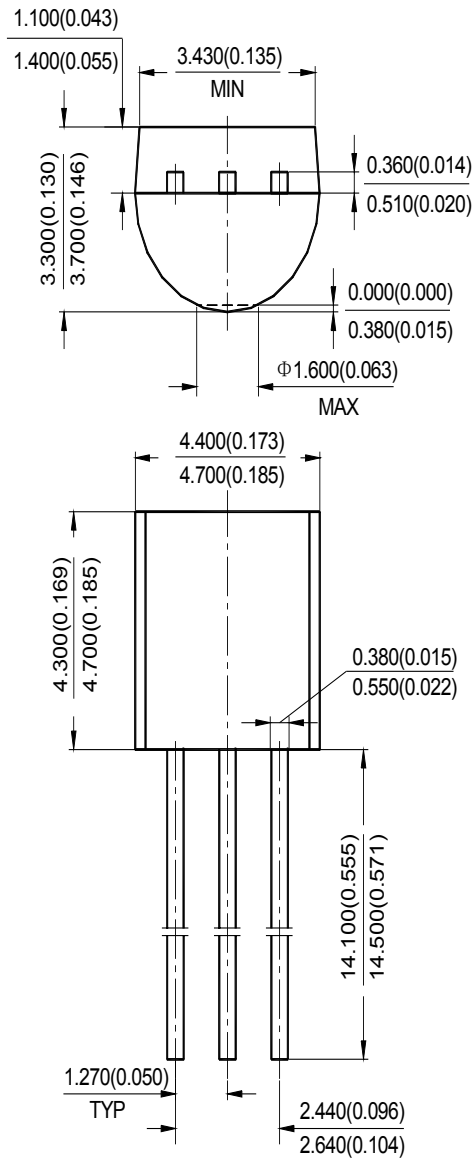

Mechanical Dimensions (Continued)

NSOIC-8

Unit: mm(inch)

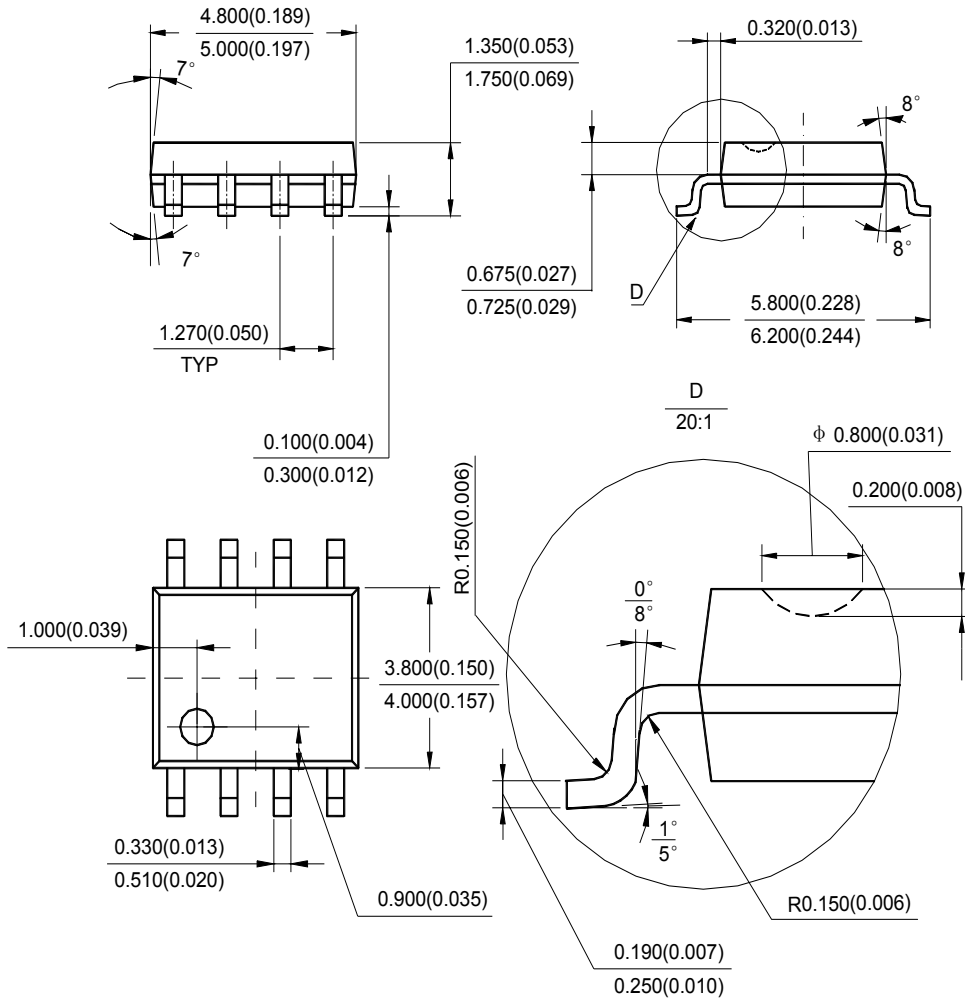

Mechanical Dimensions (Continued):

SOT-223

Unit: mm(inch)

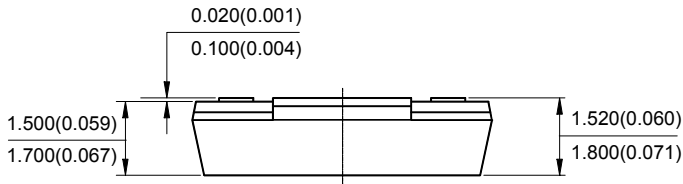
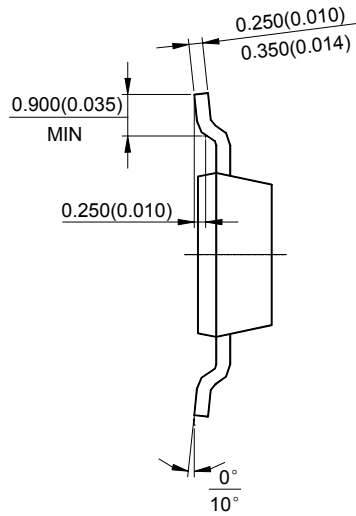
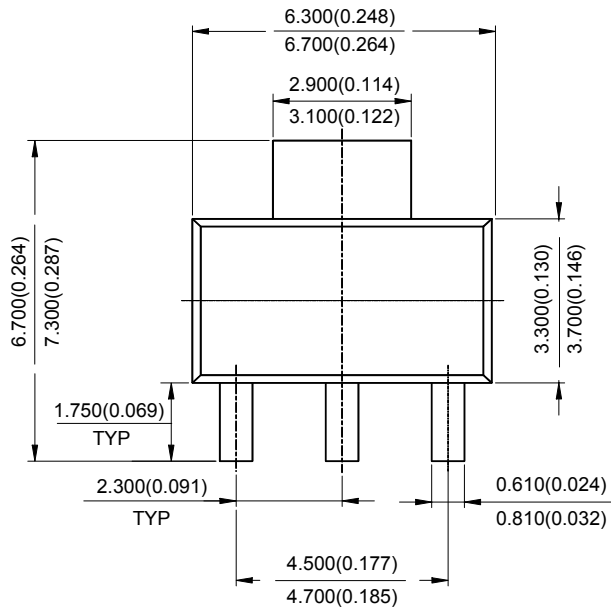

ORDERING INFORMATION

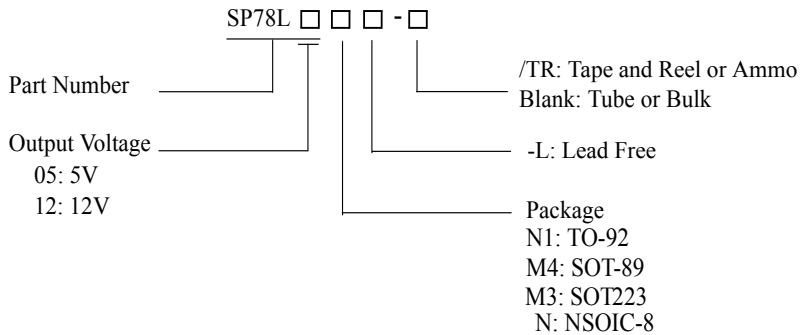

Sipex Corporation's Pb-free products, as designated with "-L" suffix in the part number, are RoHS compliant.

Part Number	Temperature Range	Voltage Tolerance	Output Voltage	Package	Pin Count	Packing Type
SP78L05N1-L/TR	0°C to +125°C	±5%	5V	TO-92	3	2,000/AMMO
SP78L12N1-L/TR	0°C to +125°C	±5%	12V	TO-92	3	2,000/AMMO
SP78L05N-L	0°C to +125°C	±5%	5V	NSOIC 8	8	100/TUBE
SP78L05N-L/TR	0°C to +125°C	±5%	5V	NSOIC 8	8	2,500/TR
SP78L12N-L	0°C to +125°C	±5%	12V	NSOIC 8	8	100/TUBE
SP78L12N-L/TR	0°C to +125°C	±5%	12V	NSOIC 8	8	2,500/TR
SP78L05M3-L/TR	0°C to +125°C	±5%	5V	SOT-223	3	2,500/TR
SP78L12M3-L/TR	0°C to +125°C	±5%	12V	SOT-223	3	2,500/TR
SP78L05M4-L/TR	0°C to +125°C	±5%	5V	SOT-89	3	1,000/TR
SP78L12M4-L/TR	0°C to +125°C	±5%	12V	SOT-89	3	1,000/TR



Sipex Corporation

Headquarters and
Sales Office
233 South Hillview Drive
Milpitas, CA 95035
TEL: (408) 934-7500
FAX: (408) 935-7600

Sipex Corporation reserves the right to make changes to any products described herein. Sipex does not assume any liability arising out of the application or use of any product or circuit described herein; neither does it convey