

### 3.0A, 150Khz, Step-Down Switching Regulator

### LM2596

#### FEATURES

- 3.3V, 5.0V, 12V, 15V, and Adjustable Output Versions
- Adjustable Version Output Voltage Range, 1.23 to 37V +/- 4%. Maximum Over Line and Load Conditions
- Guaranteed 3.0A Output Current
- Wide Input Voltage Range
- Requires Only 4 External Components
- 150Khz Fixed Frequency Internal Oscillator
- TTL Shutdown Capability, Low Power Standby Mode
- High Efficiency
- Uses Readily Available Standard Inductors
- Thermal Shutdown and Current Limit Protection
- Moisture Sensitivity Level(MSL) Equals1

#### Applications

- Simple High-Efficiency Step-Down(Buck) Regulator
- Efficient Pre-Regulator for Linear Regulators
- On-Card Switching Regulators
- Positive to Negative Converter(Buck-Boost)
- Negative Step-Up Converters
- Power Supply for Battery Chargers

#### DESCRIPTION

The LM2596 series of regulators are monolithic integrated circuits ideally suited for easy and convenient design of a step-down switching regulator(buck converter).

All circuits of this series are capable of driving a 3.0A load with excellent line and load regulation. These devices are available in fixed output voltages of 3.3V, 5.0V,12V, 15V, and an adjustable output version.

These regulators were designed to minimize the number of external components to simplify the power supply design. Standard series of inductors optimized for use with the LM2576 are offered by several different inductor manufacturers.

Since the LM2596 converter is a switch-mode power supply, its efficiency is significantly higher in comparison with popular three-terminal linear regulators, especially with higher input voltages.

In many cases, the power dissipated is so low that no heatsink is required or its size could be reduced dramatically. A standard series of inductors optimized for use with the LM2596 are available from several different manufacturers. This feature greatly simplifies the design of switch-mode power supplies. The LM2596 features include a guaranteed +/- 4% tolerance on output voltage within specified input voltages and output load conditions, and +/-15% on the oscillator frequency (+/- 2% over 0oC to 125 oC).

External shutdown is included, featuring 80 uA(typical) standby current. The output switch includes cycle-by-cycle current limiting, as well as thermal shutdown for full protection under fault conditions.

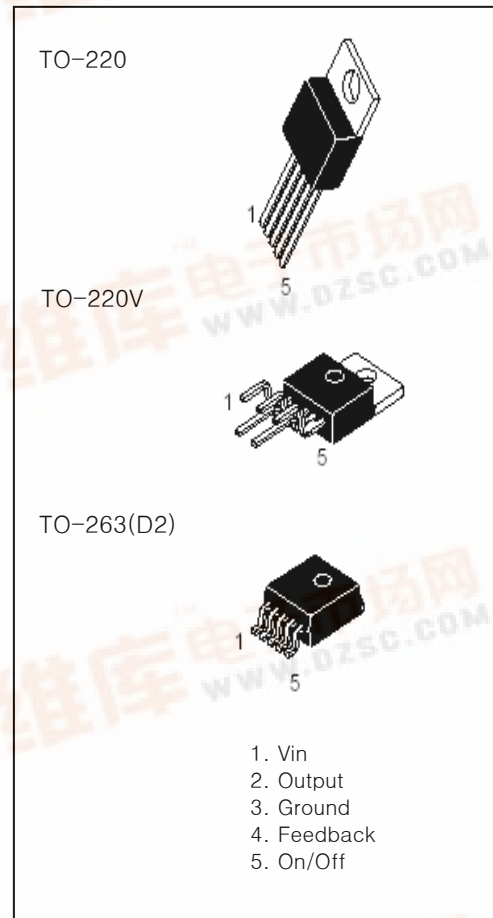

#### ORDERING INFORMATION

| Device       | Marking     | Package |
|--------------|-------------|---------|
| LM2596T-X.X  | LM2596T-X.X | TO-220  |
| LM2596TV-X.X | LM2596T-X.X | TO-220V |
| LM2596R      | LM2596R-X.X | TO-263  |

## Typical Application (Fixed Output Voltage Versions)

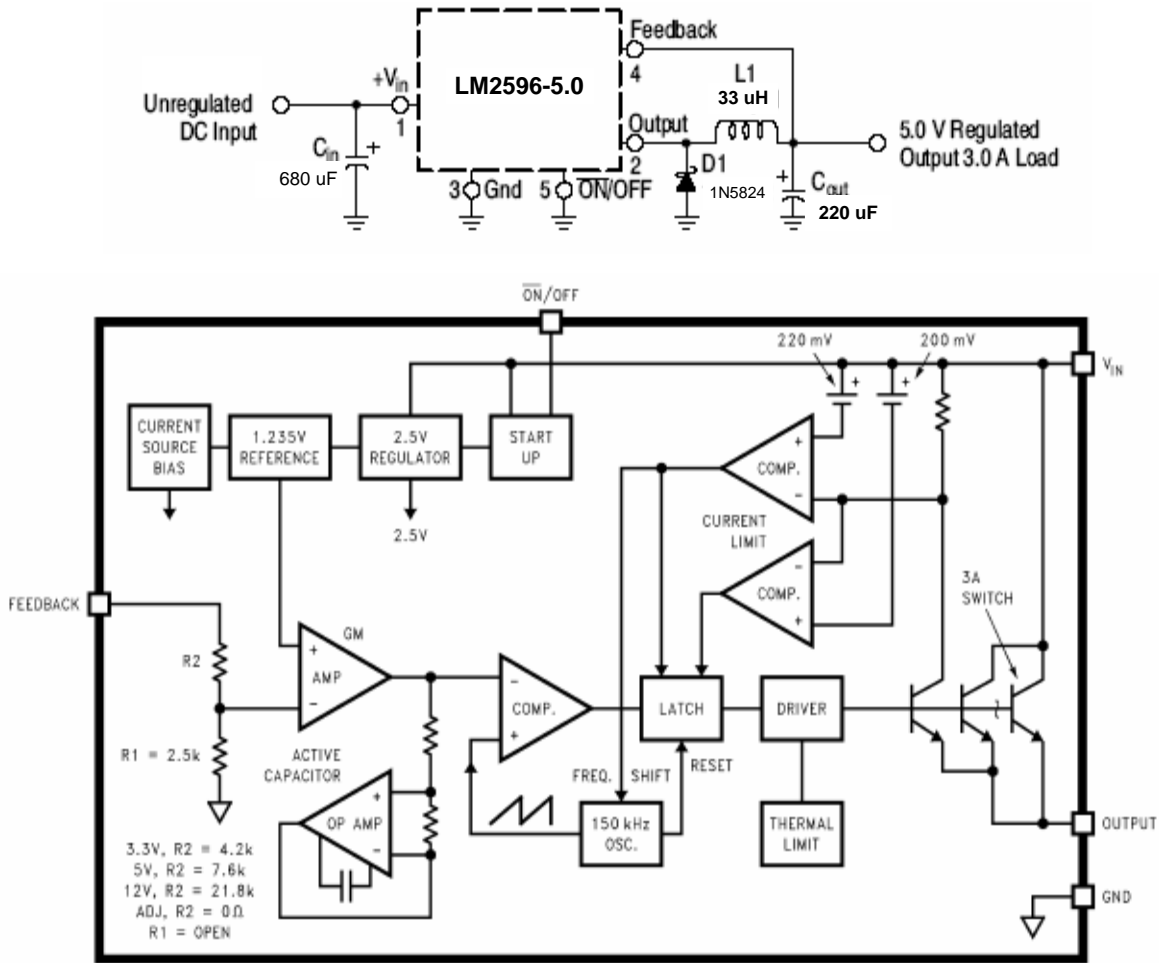

Figure 1. Block Diagram and Typical Application

### ABSOLUTE MAXIMUM RATINGS

(Absolute Maximum Ratings indicate limits beyond which damage to the device may occur.)

| Rating   | Symbol                                      | Value                                | Unit  |
|--|---|--------------------------------------|---|
| Maximum Supply Voltage   | $V_{in}$                                    | 45                                   | V   |
| ON/OFF Pin Input Voltage   | -   | $-0.3 \text{ V} \leq V \leq +V_{in}$ | V   |
| Output Voltage to Ground (Steady-State)  | -   | -1.0                                 | V   |
| Power Dissipation<br>TO-220, 5-Lead<br>Thermal Resistance, Junction-to-Ambient<br>Thermal Resistance, Junction-to-case | $P_D$<br>$R_{\theta JA}$<br>$R_{\theta JC}$ | Internally Limited<br>65<br>5.0      | W<br>$^{\circ}\text{C/W}$<br>$^{\circ}\text{C/W}$ |
| TO-263<br>Thermal Resistance, Junction-to-Ambient<br>Thermal Resistance, Junction-to-case                              | $P_D$<br>$R_{\theta JA}$<br>$R_{\theta JC}$ | Internally Limited<br>70<br>5.0      | W<br>$^{\circ}\text{C/W}$<br>$^{\circ}\text{C/W}$ |
| Storage Temperature Range  | $T_{stg}$                                   | -65 to +150                          | $^{\circ}\text{C}$                                |
| Minimum ESD Rating (Human Body Model:<br>C = 100 pF, R = 1.5 kΩ)   | -   | 2.0                                  | kV  |
| Lead Temperature (Soldering, 10 seconds)   | -   | 260                                  | $^{\circ}\text{C}$                                |
| Maximum Junction Temperature   | $T_J$                                       | 150                                  | $^{\circ}\text{C}$                                |

### 3.0A, 15V, Step-Down Switching Regulator

### LM2596

**OPERATING RATINGS** (Operating Ratings indicate conditions for which the device is intended to be functional, but do not guarantee specific performance limits. For guaranteed specifications and test conditions, see the Electrical Characteristics.)

| Rating                               | Symbol   | Value       | Unit |
|--------------------------------------|----------|-------------|------|
| Operating Junction Temperature Range | $T_J$    | -40 to +125 | °C   |
| Supply Voltage                       | $V_{in}$ | 40          | V    |

#### ELECTRICAL CHARACTERISTICS / SYSTEM PARAMETERS ([Note 1] Test Circuit Figure 2)

(Unless otherwise specified,  $V_{in} = 12\text{ V}$  for the 3.3 V, 5.0 V, and Adjustable version,  $V_{in} = 25\text{ V}$  for the 12 V version, and  $V_{in} = 30\text{ V}$  for the 15 V version.  $I_{Load} = 500\text{ mA}$ . For typical values  $T_J = 25^\circ\text{C}$ , for min/max values  $T_J$  is the operating junction temperature range that applies [Note 2], unless otherwise noted.)

| Characteristics  | Symbol    | Min            | Typ       | Max            | Unit |
|--|-----------|----------------|-----------|----------------|------|
| <b>LM2596-3.3</b> ([ Note 1]. Test Circuit Figure 2 )  |           |                |           |                |      |
| Output Voltage ( $V_{in} = 12\text{ V}$ , $I_{Load} = 0.5\text{ A}$ , $T_J = 25^\circ\text{C}$ )   | $V_{out}$ | 3.234          | 3.3       | 3.366          | V    |
| Output Voltage ( $6.0\text{ V} \leq V_{in} \leq 40\text{ V}$ , $0.5\text{ A} \leq I_{Load} \leq 3.0\text{ A}$ )<br>$T_J = 25^\circ\text{C}$<br>$T_J = -40\text{ to }+125^\circ\text{C}$                              | $V_{out}$ | 3.168<br>3.135 | 3.3<br>–  | 3.432<br>3.465 | V    |
| Efficiency ( $V_{in} = 12\text{ V}$ , $I_{Load} = 3.0\text{ A}$ )  | $\eta$    | –              | 73        | –              | %    |
| <b>LM2596-5.0</b> ([ Note 1]. Test Circuit Figure 2 )  |           |                |           |                |      |
| Output Voltage ( $V_{in} = 12\text{ V}$ , $I_{Load} = 0.5\text{ A}$ , $T_J = 25^\circ\text{C}$ )   | $V_{out}$ | 4.9            | 5.0       | 5.1            | V    |
| Output Voltage ( $8.0\text{ V} \leq V_{in} \leq 40\text{ V}$ , $0.5\text{ A} \leq I_{Load} \leq 3.0\text{ A}$ )<br>$T_J = 25^\circ\text{C}$<br>$T_J = -40\text{ to }+125^\circ\text{C}$                              | $V_{out}$ | 4.8<br>4.75    | 5.0<br>–  | 5.2<br>5.25    | V    |
| Efficiency ( $V_{in} = 12\text{ V}$ , $I_{Load} = 3.0\text{ A}$ )  | $\eta$    | –              | 80        | –              | %    |
| <b>LM2596-12</b> ([ Note 1]. Test Circuit Figure 2 )   |           |                |           |                |      |
| Output Voltage ( $V_{in} = 25\text{ V}$ , $I_{Load} = 0.5\text{ A}$ , $T_J = 25^\circ\text{C}$ )   | $V_{out}$ | 11.76          | 12        | 12.24          | V    |
| Output Voltage ( $15\text{ V} \leq V_{in} \leq 40\text{ V}$ , $0.5\text{ A} \leq I_{Load} \leq 3.0\text{ A}$ )<br>$T_J = 25^\circ\text{C}$<br>$T_J = -40\text{ to }+125^\circ\text{C}$                               | $V_{out}$ | 11.52<br>11.4  | 12<br>–   | 12.48<br>12.6  | V    |
| Efficiency ( $V_{in} = 15\text{ V}$ , $I_{Load} = 3.0\text{ A}$ )  | $\eta$    | –              | 90        | –              | %    |
| <b>LM2596-15</b> ([ Note 1]. Test Circuit Figure 2 )   |           |                |           |                |      |
| Output Voltage ( $V_{in} = 30\text{ V}$ , $I_{Load} = 0.5\text{ A}$ , $T_J = 25^\circ\text{C}$ )   | $V_{out}$ | 14.7           | 15        | 15.3           | V    |
| Output Voltage ( $18\text{ V} \leq V_{in} \leq 40\text{ V}$ , $0.5\text{ A} \leq I_{Load} \leq 3.0\text{ A}$ )<br>$T_J = 25^\circ\text{C}$<br>$T_J = -40\text{ to }+125^\circ\text{C}$                               | $V_{out}$ | 14.4<br>14.25  | 15<br>–   | 15.6<br>15.75  | V    |
| Efficiency ( $V_{in} = 18\text{ V}$ , $I_{Load} = 3.0\text{ A}$ )  | $\eta$    | –              | 98        | –              | %    |
| <b>LM2596-ADJ</b> ([ Note 1]. Test Circuit Figure 2 )  |           |                |           |                |      |
| Feedback Voltage ( $V_{in} = 12\text{ V}$ , $I_{Load} = 0.5\text{ A}$ , $V_{out} = 5.0\text{ V}$ , $T_J = 25^\circ\text{C}$ )  | $V_{out}$ | 1.217          | 1.23      | 1.243          | V    |
| Feedback Voltage ( $8.0\text{ V} \leq V_{in} \leq 40\text{ V}$ , $0.5\text{ A} \leq I_{Load} \leq 3.0\text{ A}$ , $V_{out} = 5.0\text{ V}$ )<br>$T_J = 25^\circ\text{C}$<br>$T_J = -40\text{ to }+125^\circ\text{C}$ | $V_{out}$ | 1.193<br>1.18  | 1.23<br>– | 1.267<br>1.28  | V    |
| Efficiency ( $V_{in} = 12\text{ V}$ , $I_{Load} = 3.0\text{ A}$ , $V_{out} = 5.0\text{ V}$ )   | $\eta$    | –              | 73        | –              | %    |

### 3.0A, 15V, Step-Down Switching Regulator

### LM2596

#### ELECTRICAL CHARACTERISTICS / Device Parameters

(Unless otherwise specified,  $V_{in} = 12\text{ V}$  for the 3.3 V, 5.0 V, and Adjustable version,  $V_{in} = 25\text{ V}$  for the 12 V version, and  $V_{in} = 30\text{ V}$  for the 15 V version.  $I_{Load} = 500\text{ mA}$ . For typical values  $T_J = 25^\circ\text{C}$ , for min/max values  $T_J$  is the operating junction temperature range that applies [Note 2], unless otherwise noted.)

| Characteristics   | Symbol     | Min        | Typ           | Max        | Unit          |
|---|------------|------------|---------------|------------|---------------|
| <b>ALL OUTPUT VOLTAGE VERSIONS</b>  |            |            |               |            |               |
| Feedback Bias Current ( $V_{out} = 5.0\text{ V}$ [Adjustable Version Only])<br>$T_J = 25^\circ\text{C}$<br>$T_J = 0\text{ to }+125^\circ\text{C}$   | $I_b$      | –<br>–     | 10<br>–       | 50<br>100  | nA            |
| Oscillator Frequency [Note 3]<br>$T_J = 25^\circ\text{C}$<br>$T_J = 0\text{ to }+125^\circ\text{C}$   | $f_{osc}$  | 127<br>110 | 150<br>–<br>– | 173<br>173 | kHz           |
| Saturation Voltage ( $I_{out} = 3.0\text{ A}$ [Note 4])<br>$T_J = 25^\circ\text{C}$<br>$T_J = 0\text{ to }+125^\circ\text{C}$   | $V_{sat}$  | –<br>–     | 1.16<br>–     | 1.4<br>1.5 | V             |
| Max Duty Cycle (“on”) [Note 5]  | DC         | –          | 100           | –          | %             |
| Current Limit (Peak Current [Notes 3 and 4])<br>$T_J = 25^\circ\text{C}$<br>$T_J = 0\text{ to }+125^\circ\text{C}$  | $I_{CL}$   | 3.6<br>3.4 | 4.5<br>–      | 6.9<br>7.5 | A             |
| Output Leakage Current [Notes 6 and 7], $T_J = 25^\circ\text{C}$<br>Output = 0 V<br>Output = –1.0 V   | $I_L$      | –<br>–     | –<br>2        | 50<br>30   | mA            |
| Quiescent Current [Note 6]<br>$T_J = 25^\circ\text{C}$<br>$T_J = 0\text{ to }+125^\circ\text{C}$  | $I_Q$      | –<br>–     | 5<br>–        | –<br>10    | mA            |
| Standby Quiescent Current ( $\overline{ON}/OFF$ Pin = 5.0 V (“off”))<br>$T_J = 25^\circ\text{C}$<br>$T_J = 0\text{ to }+125^\circ\text{C}$  | $I_{stby}$ | –<br>–     | 80<br>–       | 200<br>250 | $\mu\text{A}$ |
| $\overline{ON}/OFF$ Pin Logic Input Level (Test Circuit Figure 2 )<br>$V_{out} = 0\text{ V}$<br>$T_J = 25^\circ\text{C}$<br>$T_J = 0\text{ to }+125^\circ\text{C}$<br>$V_{out} = \text{Nominal Output Voltage}$<br>$T_J = 25^\circ\text{C}$<br>$T_J = 0\text{ to }+125^\circ\text{C}$ | $V_{IH}$   | –          | 1.3<br>–      | 0.6<br>0.6 | V             |
|   | $V_{IL}$   | 2.0<br>2.0 | 1.3<br>–      | –<br>–     |               |
| $\overline{ON}/OFF$ Pin Input Current (Test Circuit Figure 2 )<br>$V_{LOGIC} = 2.5\text{ V}$ (Regulator OFF)<br>$V_{LOGIC} = 0.5\text{ V}$ (Regulator ON)   | $I_{IH}$   | –          | 5             | 15         | $\mu\text{A}$ |
|   | $I_{IL}$   | –          | 0.02          | 5.0        |               |

- External components such as the catch diode, inductor, input and output capacitors can affect switching regulator system performance.  
When the LM2596 is used as shown in the Figure 1 test circuit, system performance will be as shown in system parameters section .
- Tested junction temperature range for the LM2596 :  $T_{LOW} = -0^\circ\text{C}$   $T_{HIGH} = +125^\circ\text{C}$
- The oscillator frequency reduces to approximately 18 kHz in the event of an output short or an overload which causes the regulated output voltage to drop approximately 40% from the nominal output voltage. This self protection feature lowers the average dissipation of the IC by lowering the minimum duty cycle from 5% down to approximately 2%.
- Output (Pin 2) sourcing current. No diode, inductor or capacitor connected to output pin.
- Feedback (Pin 4) removed from output and connected to 0 V.
- Feedback (Pin 4) removed from output and connected to +12 V for the Adjustable, 3.3 V, and 5.0V versions, and +25 V for the 12 V and 15 V versions, to force the output transistor “off”.
- $V_{in} = 40\text{ V}$ .

## TYPICAL PERFORMANCE CHARACTERISTICS (Circuit of Figure 2)

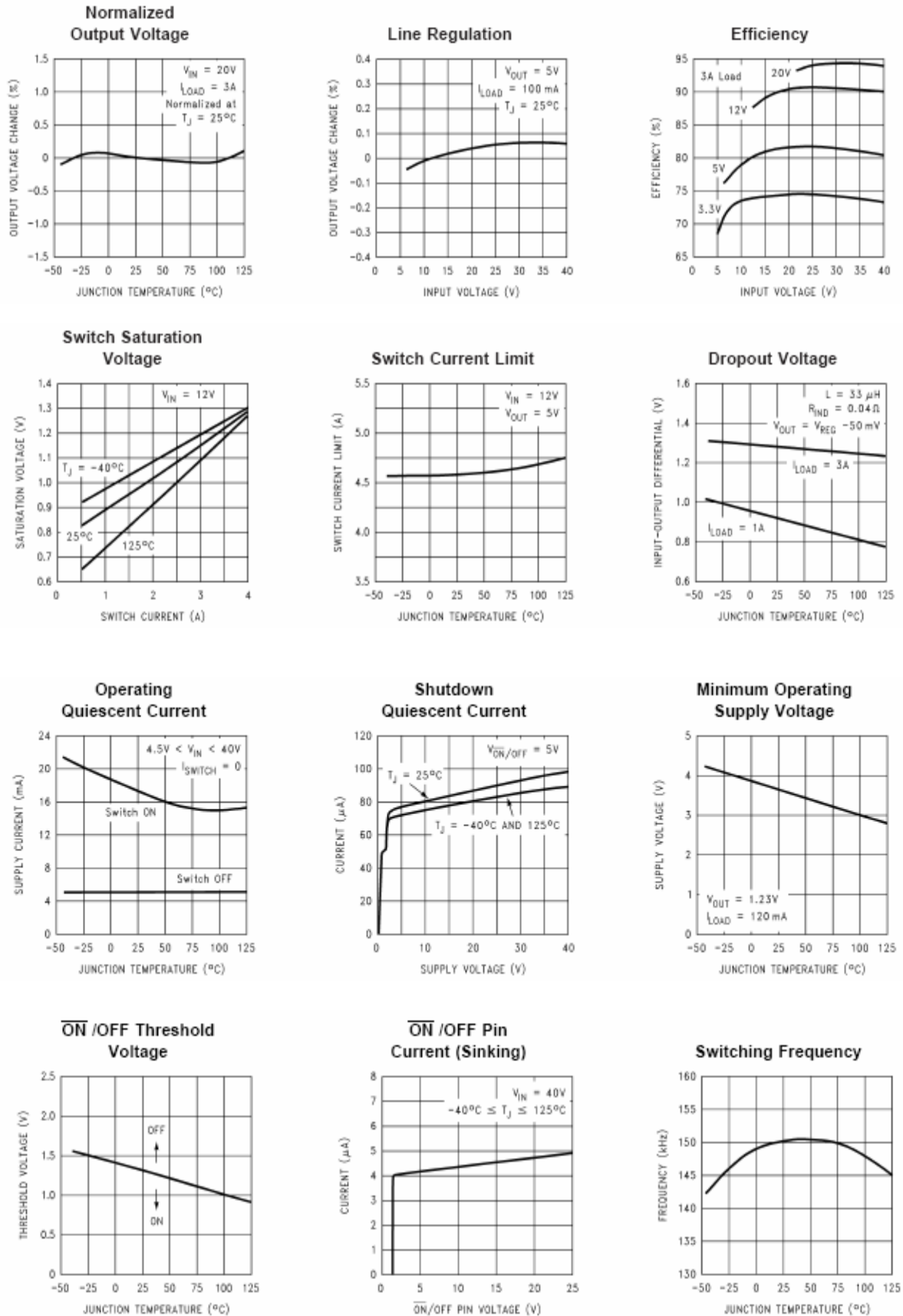

## TYPICAL PERFORMANCE CHARACTERISTICS (Circuit of Figure 2)

**Feedback Pin Bias Current**

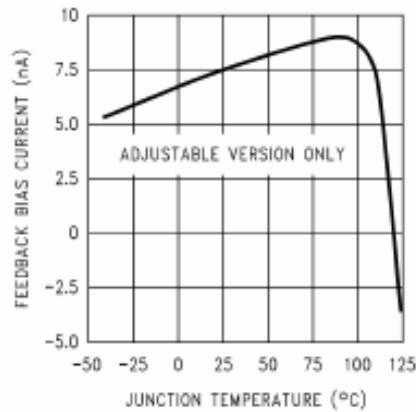

**Continuous Mode Switching Waveforms**  
 $V_{IN} = 20V, V_{OUT} = 5V, I_{LOAD} = 2A$   
 $L = 32 \mu H, C_{OUT} = 220 \mu F, C_{OUT} ESR = 50 m\Omega$

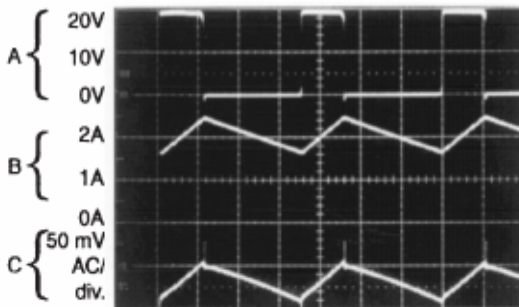

Horizontal Time Base: 2  $\mu s$ /div.

- A: Output Pin Voltage, 10V/div.
- B: Inductor Current 1A/div.
- C: Output Ripple Voltage, 50 mV/div.

**Discontinuous Mode Switching Waveforms**  
 $V_{IN} = 20V, V_{OUT} = 5V, I_{LOAD} = 500 mA$   
 $L = 10 \mu H, C_{OUT} = 330 \mu F, C_{OUT} ESR = 45 m\Omega$

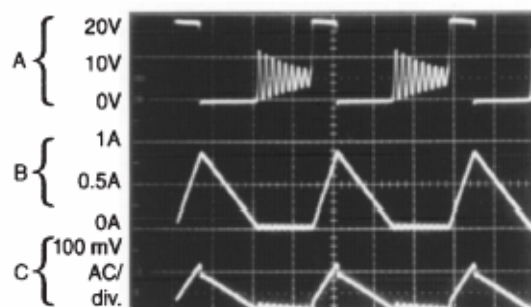

Horizontal Time Base: 2  $\mu s$ /div.

- A: Output Pin Voltage, 10V/div.
- B: Inductor Current 0.5A/div.
- C: Output Ripple Voltage, 100 mV/div.

**Load Transient Response for Continuous Mode**  
 $V_{IN} = 20V, V_{OUT} = 5V, I_{LOAD} = 500 mA$  to 2A  
 $L = 32 \mu H, C_{OUT} = 220 \mu F, C_{OUT} ESR = 50 m\Omega$

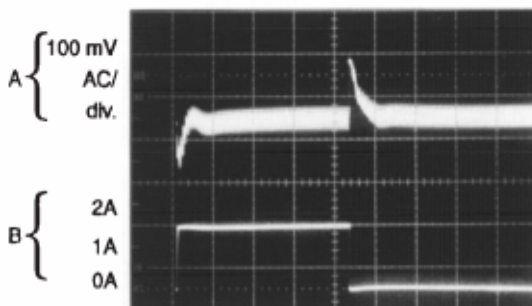

Horizontal Time Base: 100  $\mu s$ /div.

- A: Output Voltage, 100 mV/div. (AC)
- B: 500 mA to 2A Load Pulse

**Load Transient Response for Discontinuous Mode**  
 $V_{IN} = 20V, V_{OUT} = 5V, I_{LOAD} = 500 mA$  to 2A  
 $L = 10 \mu H, C_{OUT} = 330 \mu F, C_{OUT} ESR = 45 m\Omega$

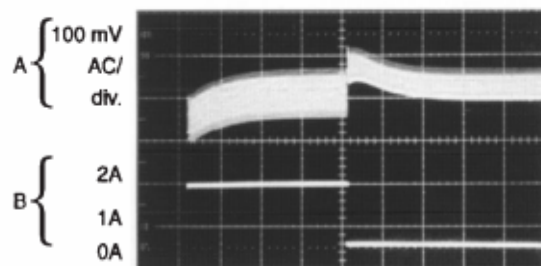

Horizontal Time Base: 200  $\mu s$ /div.

- A: Output Voltage, 100 mV/div. (AC)
- B: 500 mA to 2A Load Pulse

Test Circuit and Layout Guidelines

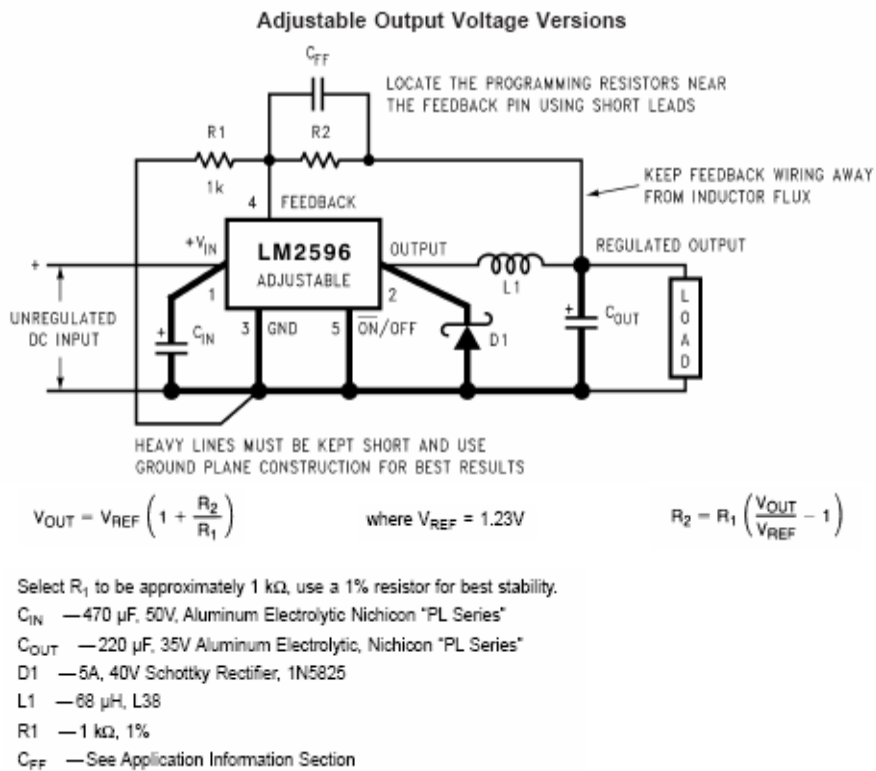
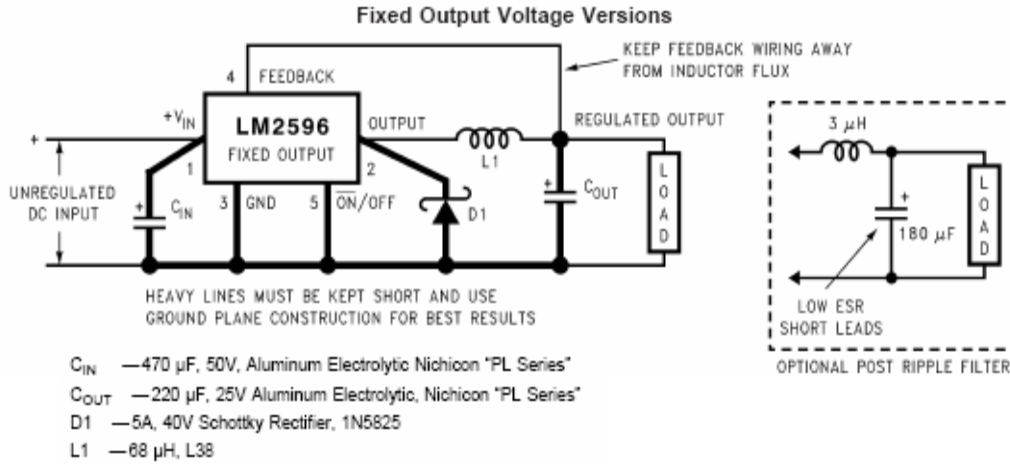

Figure 2. Typical Test Circuits and Layout Guide

As in any switching regulator, layout is very important. Rapidly switching currents associated with wiring inductance can generate voltage transients which can cause problems. For minimal inductance and ground loops, the wires indicated by heavy lines should be wide printed circuit traces and should be kept as short as possible. For best results, external components should be located as close to the switcher IC as possible using ground plane construction or single point grounding.

If open core inductors are used, special care must be taken as to the location and positioning of this type of inductor. Allowing the inductor flux to intersect sensitive feedback, IC groundpath and COUT wiring can cause problems.

When using the adjustable version, special care must be taken as to the location of the feedback resistors and the associated wiring. Physically locate both resistors near the IC, and route the wiring away from the inductor, especially an open core type of inductor.

## PIN FUNCTION DESCRIPTION

|   | Symbol   | Description   |
|---|----------|---|
| 1 | $V_{in}$ | This pin is the positive input supply for the LM2596 step-down switching regulator. In order to minimize voltage transients and to supply the switching currents needed by the regulator, a suitable input bypass capacitor must be present. ( $C_{in}$ in Figure 1).   |
| 2 | Output   | This is the emitter of the internal switch. The saturation voltage $V_{sat}$ of this output switch is typically 1.5 V. It should be kept in mind that the PCB area connected to this pin should be kept to a minimum in order to minimize coupling to sensitive circuitry.  |
| 3 | Gnd      | Circuit ground pin. See the information about the printed circuit board layout.   |
| 4 | Feedback | This pin senses regulated output voltage to complete the feedback loop. The signal is divided by the internal resistor divider network R2, R1 and applied to the non-inverting input of the internal error amplifier. In the Adjustable version of the LM2596 switching regulator this pin is the direct input of the error amplifier and the resistor network R2, R1 is connected externally to allow programming of the output voltage. |
| 5 | ON/OFF   | It allows the switching regulator circuit to be shut down using logic level signals, thus dropping the total input supply current to approximately 80 mA. The threshold voltage is typically 1.4 V. Applying a voltage above this value (up to $+V_{in}$ ) shuts the regulator off. If the voltage applied to this pin is lower than 1.4V or if this pin is left open, the regulator will be in the "on" condition                        |



PACKAGES DIMENSION : TO220-5L

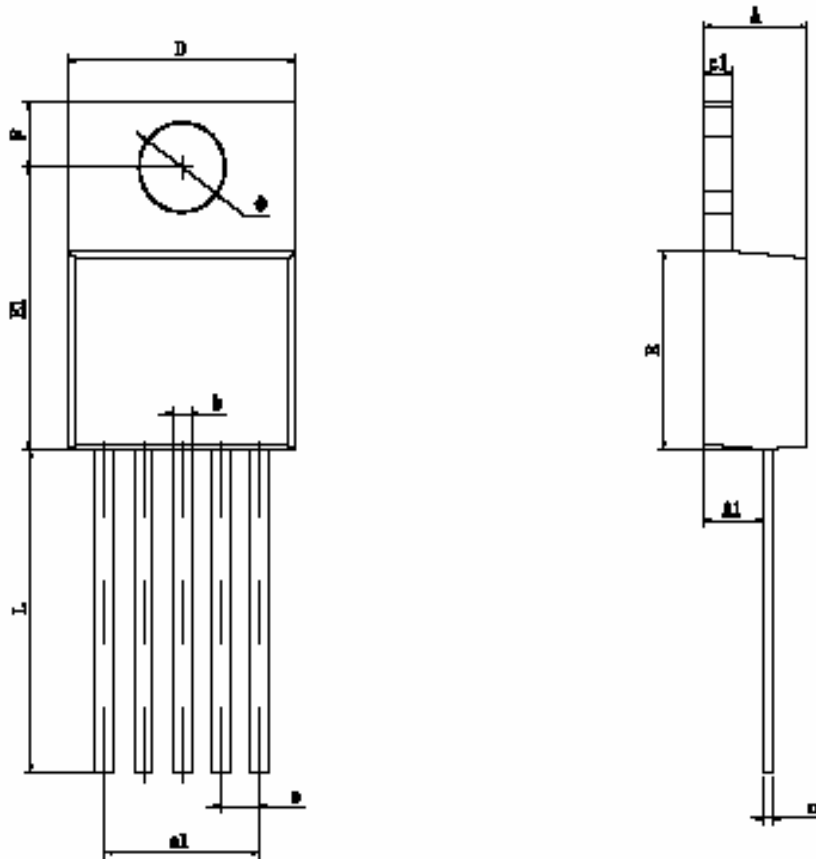

| Symbol | Dimensions In Millimeters |        | Dimensions In Inches |       |
|--------|---------------------------|--------|----------------------|-------|
|        | Min                       | Max    | Min                  | Max   |
| A      | 4.470                     | 4.670  | 0.176                | 0.184 |
| A1     | 2.520                     | 2.820  | 0.099                | 0.111 |
| b      | 0.710                     | 0.910  | 0.028                | 0.036 |
| c      | 0.310                     | 0.530  | 0.012                | 0.021 |
| c1     | 1.170                     | 1.370  | 0.046                | 0.054 |
| D      | 9.850                     | 10.150 | 0.388                | 0.400 |
| E      | 8.200                     | 8.600  | 0.323                | 0.339 |
| E1     | 11.760                    | 12.160 | 0.463                | 0.479 |
| e      | 1.700TYP                  |        | 0.067TYP             |       |
| e1     | 6.700                     | 6.900  | 0.264                | 0.272 |
| F      | 2.590                     | 2.890  | 0.102                | 0.114 |
| L      | 13.500                    | 13.900 | 0.531                | 0.547 |
| Φ      | 3.790                     | 3.890  | 0.149                | 0.153 |

### 3.0A, 15V, Step-Down Switching Regulator

LM2596

PACKAGES DIMENSION : TO220V-5L

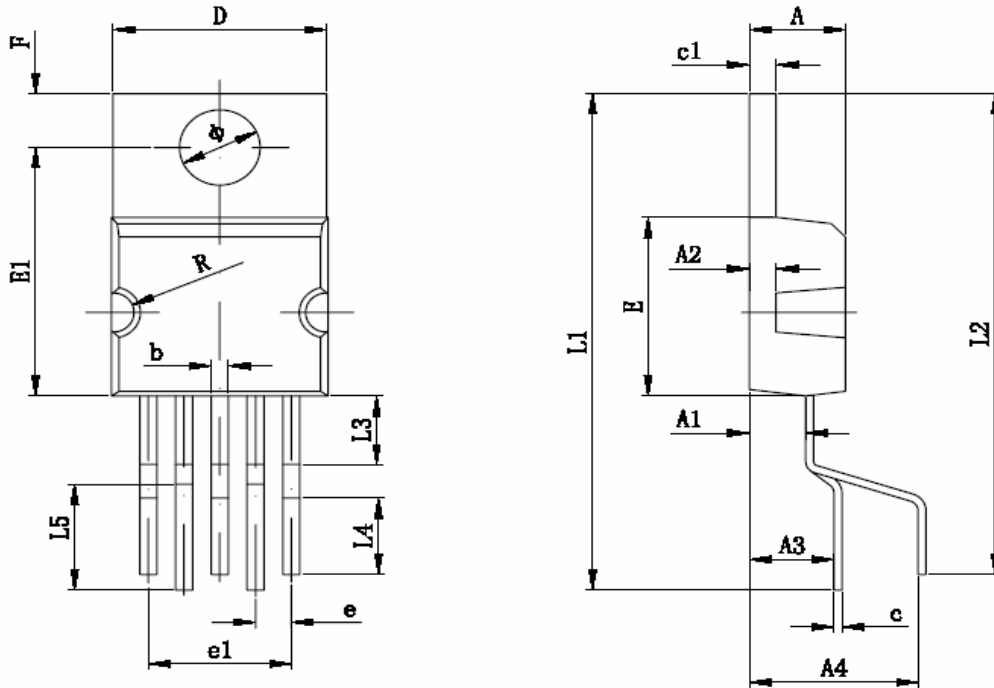

| Symbol | Dimensions In Millimeters |        | Dimensions In Inches |       |
|--------|---------------------------|--------|----------------------|-------|
|        | Min                       | Max    | Min                  | Max   |
| A      | 4.470                     | 4.670  | 0.176                | 0.184 |
| A1     | 2.520                     | 2.820  | 0.099                | 0.111 |
| A2     | 1.170                     | 1.370  | 0.046                | 0.054 |
| A3     | 4.250                     | 4.550  | 0.167                | 0.179 |
| A4     | 8.250                     | 8.550  | 0.325                | 0.337 |
| b      | 0.710                     | 0.910  | 0.028                | 0.036 |
| c      | 0.310                     | 0.530  | 0.012                | 0.021 |
| c1     | 1.170                     | 1.370  | 0.046                | 0.054 |
| D      | 10.010                    | 10.310 | 0.394                | 0.406 |
| E      | 8.900                     | 9.300  | 0.350                | 0.366 |
| E1     | 12.460                    | 12.860 | 0.491                | 0.506 |
| e      | 1.700TYP                  |        | 0.220TYP             |       |
| e1     | 6.700                     | 6.900  | 0.264                | 0.272 |
| e2     | 3.300                     | 3.500  | 0.130                | 0.138 |
| F      | 2.590                     | 2.890  | 0.102                | 0.114 |
| L1     | 25.100                    | 25.500 | 0.988                | 1.004 |
| L2     | 24.300                    | 24.700 | 0.957                | 0.972 |
| L3     | 3.400                     | 3.600  | 0.134                | 0.142 |
| L4     | 3.800                     | 4.000  | 0.150                | 0.157 |
| L5     | 5.300                     | 5.500  | 0.209                | 0.217 |
| R      | 0.950                     | 1.050  | 0.037                | 0.041 |
| $\Phi$ | 3.790                     | 3.890  | 0.149                | 0.153 |

### 3.0A, 15V, Step-Down Switching Regulator

LM2596

PACKAGES DIMENSION : TO263-5L

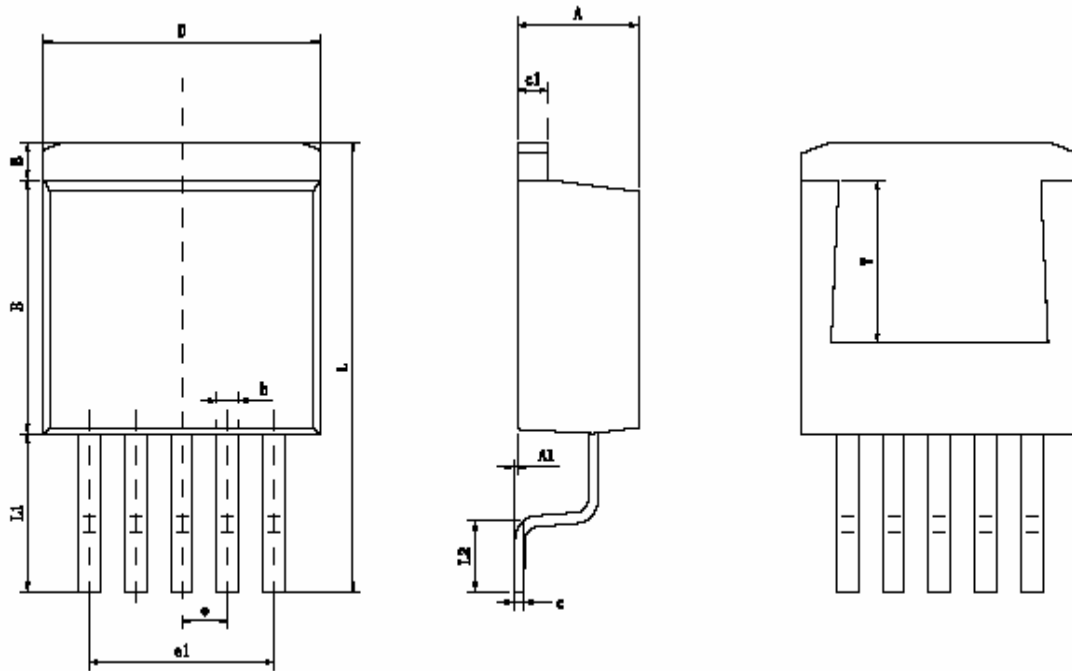

| Symbol | Dimensions In Millimeters |        | Dimensions In Inches |       |
|--------|---------------------------|--------|----------------------|-------|
|        | Min                       | Max    | Min                  | Max   |
| A      | 4.470                     | 4.670  | 0.176                | 0.184 |
| A1     | 0.000                     | 0.150  | 0.000                | 0.006 |
| B      | 1.560                     | 1.760  | 0.061                | 0.069 |
| b      | 0.710                     | 0.910  | 0.028                | 0.036 |
| c      | 0.310                     | 0.530  | 0.012                | 0.021 |
| c1     | 1.170                     | 1.370  | 0.046                | 0.054 |
| D      | 9.880                     | 10.180 | 0.389                | 0.401 |
| E      | 8.200                     | 8.600  | 0.323                | 0.339 |
| e      | 1.700TYP                  |        | 0.067TYP             |       |
| e1     | 6.700                     | 6.900  | 0.264                | 0.272 |
| L      | 15.140                    | 15.540 | 0.596                | 0.612 |
| L1     | 5.080                     | 5.480  | 0.200                | 0.216 |
| L2     | 2.340                     | 2.740  | 0.092                | 0.108 |
| V      | 5.600REF                  |        | 0.220REF             |       |