

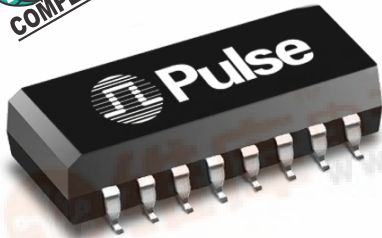





10/100 BASE-T SINGLE PORT TRANSFORMER MODULES

With 2:1 Transmit Turns Ratios Compatible with MicroLinear, MITEL, and SEEQ Transceivers



-  RoHS-5 peak reflow temperature rating 235°C
-  RoHS-6 peak reflow temperature rating 245°C
-  Patented InterlockBase design
-  Meets all IEEE 802.3 and ANSI X3.236 standards, including 350 μ H OCL with 8 mA bias
-  Various pinout options available for optimal board layout

Electrical Specifications @ 25°C — Operating Temperature 0°C to 70°C

RoHS-5 ¹ Compliant Part Number	RoHS-6 ² Compliant Part Number	Insertion Loss (dB TYP)	Rise Time (ns TYP)	Return Loss (dB TYP)		Differential to Common Mode Rejection (dB TYP)		Crosstalk (dB TYP)		Voltage Isolation (Vrms MIN)
				0.1-60 MHz	60-100 MHz	0.1-60 MHz	60-100 MHz	0.1-60 MHz	60-100 MHz	
H1038	H1038NL	-1.0	3.5	-16	-12	-35	-32	-40	-35	1500
H1090	H1090NL	-1.0	3.5	-16	-12	-35	-32	-40	-35	1500
H1094	H1094NL	-1.0	3.5	-16	-12	-35	-32	-40	-35	1500

- RoHS-5:** Product does not contain 5 out of the 6 banned substances specified in the RoHS directive (product contains lead in applications considered solder).
- RoHS-6:** Product does not contain 5 out of the 6 banned substances specified in the RoHS directive. Some internal connections may contain lead in high-temperature solder (solder alloys containing more than 85% lead).

NOTE: For Tape & Reel packaging add a "T" suffix to the part number (i.e.: H1038T).

U.S. Patent No. 5,015,981

Mechanical

H1038, H1090, H1094

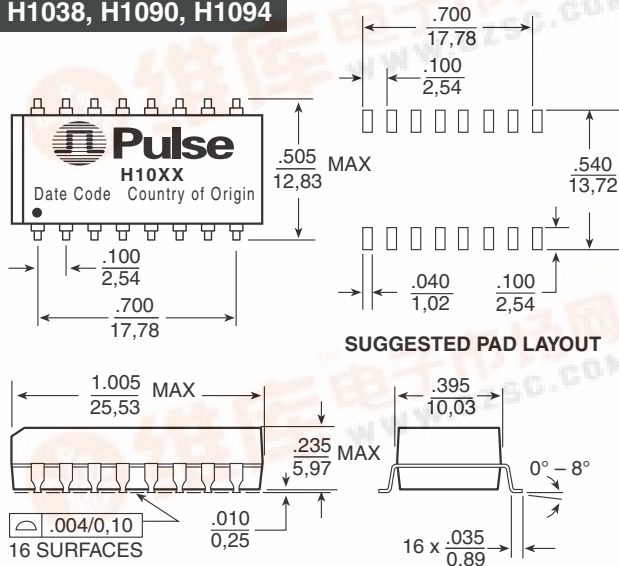

Schematics

H1038

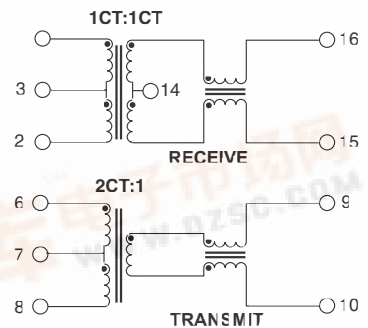

H1090

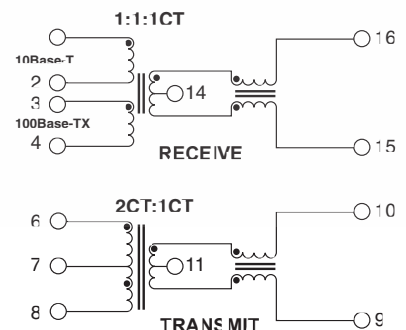

Dimensions: Inches
mm
Unless otherwise specified,
all tolerances are $\pm .010$
0,25

Weight 2.5 grams
Tube23/tube
Tape & Reel350/reel

10/100 BASE-T SINGLE PORT TRANSFORMER MODULES

With 2:1 Transmit Turns Ratios Compatible with MicroLinear, MITEL, and SEEQ Transceivers



Schematics

H1094

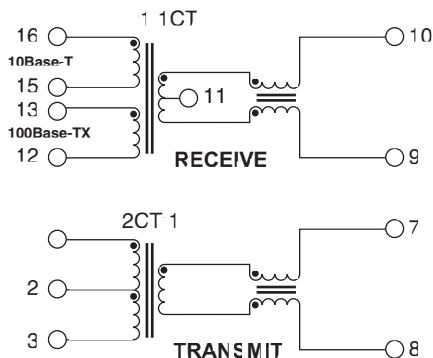

Application Notes

The magnetics modules have been specifically designed for implementation of 10/100 Mbps and 100Base-TX data links over data-grade unshielded twisted pair cable (UTP-5). The modules provide excellent EMI filtering and are targeted for adapter card and multiport applications. In designing these parts, Pulse has worked closely with members of the IEEE 802.3 and ANSI X3.236 committees to develop an analog interface that provides isolation and EMI filtering for MLT-3 and NRZ transceivers.

The H1090 and H1094 are designed to interface with the MicroLinear ML6692, ML6694, ML6697, or ML6698 in 10/100 Mbps applications. The H1038 is optimized for SEEQ or MITEL (formerly GEC Plessey) 10/100 Mbps applications.

The transformers used in the modules provide high voltage isolation, wide bandwidth, and fast rise time. They utilize stable ferrite materials to minimize the degradation of primary inductance with base-line wander. At least 350 μ H of inductance will be provided by the transformers in these modules when 0 - 8 mA is applied across the windings over a temperature range of 0° - 70°C. The High Speed LAN magnetics modules provide the designer with low cost analog components for simple and reliable designs. The parts are encased in IC-grade packaging, which shows superior performance under high temperature solder reflow conditions.

For information on TP-FDDI, Fast Ethernet, and ATM solutions, contact Pulse's HS LAN Marketing Group.

Typical Application Circuit

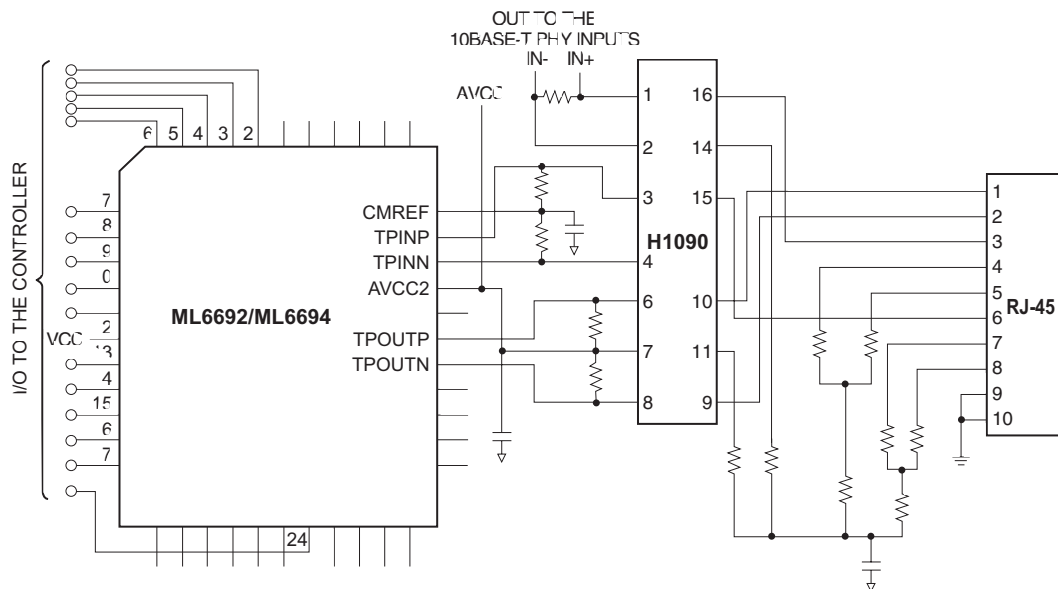

For More Information:

Pulse Worldwide Headquarters

12220 World Trade Dr.
San Diego, CA 92128
U.S.A.

www.pulseeng.com

TEL: 858 674 8100
FAX: 858 674 8262

Pulse European Headquarters

Einsteinstrasse 1
71083 Herrenberg
Germany

TEL: 49 7032 7806 0
FAX: 49 7032 7806 12

Pulse China Headquarters

No. 1
Industrial District
Changan, Dongguan
China

TEL: 86 769 85538070
FAX: 86 769 85538870

Pulse North China

Room 1503
XinYin Building
No. 888 YiShan Rd.
Shanghai 200233
China

TEL: 86 21 54643211/2
FAX: 86 21 54643210

Pulse South Asia

150 Kampong Ampat
#07-01/02
KA Centre
Singapore 368324

TEL: 65 6287 8998
FAX: 65 6280 0080

Pulse North Asia

No. 26
Kao Ching Rd.
Yang Mei Chen
Taoyuan Hsien
Taiwan, R. O. C.

TEL: 886 3 4641811
FAX: 886 3 4641911