

2001

1.0/2.3 RF Connector Series

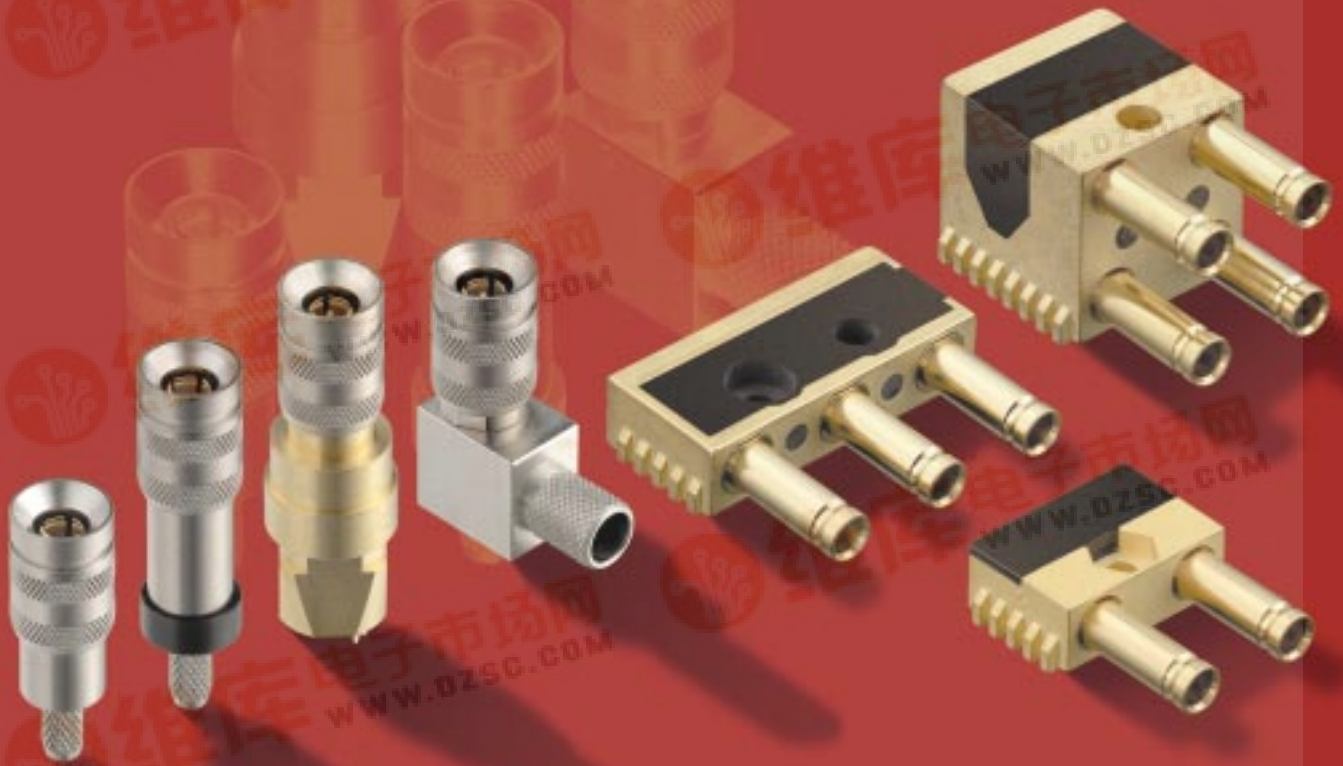

Cannon



ITT Industries
Engineered for life

Description	Page
Introduction	3
1.0/2.3 50 Ohm Range	5
1.0/2.3 75 Ohm Plugs	7
Type 54 Range	8
1.0/2.3 75 Ohm Jacks	9
MID - Surface Mount Jacks	12
Baluns	16
U - Links	17
1.0/2.3 - 1.0/2.3 In - Series Adaptors	18
1.0/2.3 - 1.6/5.6 Between - Series Adaptors	19
1.0/2.3 - BNC Between - Series Adaptors	20
Terminations & Attenuators	21
Tooling	22
Assembly Instructions	23
Part Number Index	32
Other ITT Cannon Product Listing	33
Product Safety Information	34

ITT Cannon, a Division of ITT Industries, Inc. manufactures the highest quality products available in the marketplace; however these products are intended to be used in accordance with the specifications in this publication. Any use or application that deviates from the stated operating specifications is not recommended and may be unsafe. No information and data contained in this publication shall be construed to create any liability on the part of Cannon.

Any new issue of this publication shall automatically invalidate and supersede any and all previous issues. **A limited warranty applies to Cannon products. Except for obligations assumed by Cannon under this warranty, ITT Industries shall not be liable for any loss, damage, cost of repairs, incidental or consequential damages of any kind, whether or not based on express or implied warranty, contract, negligence, or strict liability arising in connection with the design, manufacture, sale, use, or repair of the products.** Product availability, prices and delivery dates are exclusively subject to our respective order confirmation form; the same applies to orders based on development samples delivered. This publication is not to be construed as an offer. It is intended merely as an invitation to make an offer. By this publication, Cannon does not assume responsibility or any liability for any patent infringements or other rights of third parties which may result from its use. Reprinting this publication is generally permitted, indicating the source. However, Cannon's prior consent must be obtained in all cases.

Cannon is a trademark of ITT Industries, Inc.

Introduction

The ITT Industries, Cannon 1.0/2.3 Connectors are offered in both 50 ohm and 75 ohm series. These connectors are now widely used in telecommunication systems where, due to their smaller size, significant space saving can be achieved. Ideally suited to RF and high speed digital equipment, the connectors are designed to meet the requirements of CECC 22230 and DIN47247.

This range features the Push-Pull coupling mechanism to provide a secure latch that prevents accidental disconnection, whilst allowing ease of mating and unmating.

The range of parts shown in this publication includes plug and jack connectors for a variety of cables, together with PCB styles and U links. Other cable types and connector styles may be available on request.

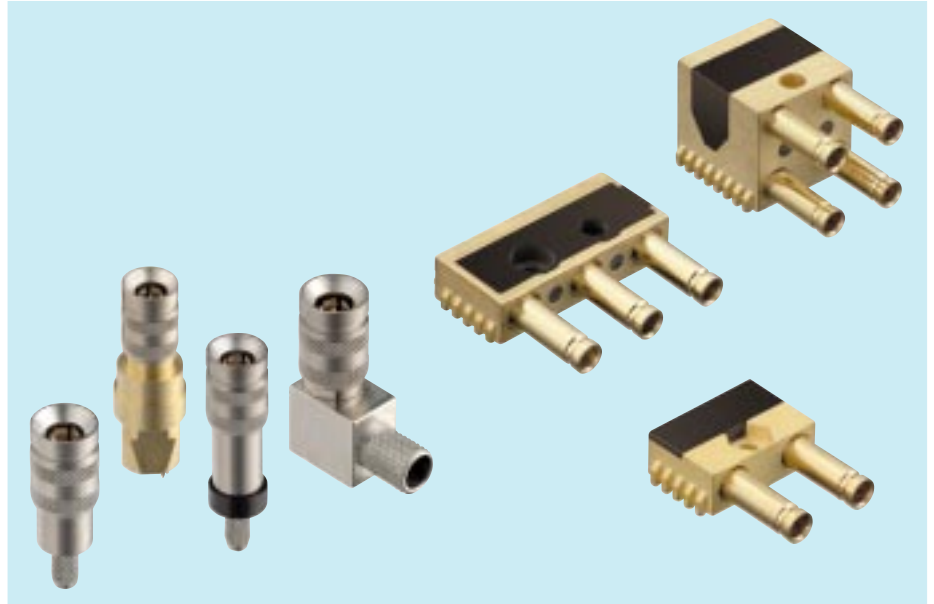

Mating Interfaces

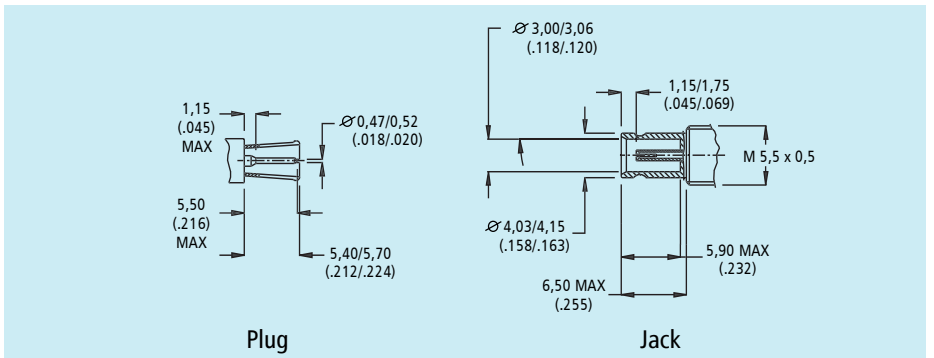

Coupling Types

Standard Push-Pull (other types: screw, snap-on, slide-in available on request)

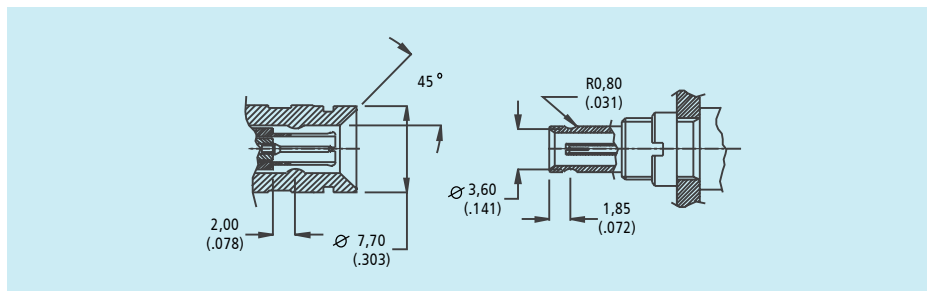

Screw Type

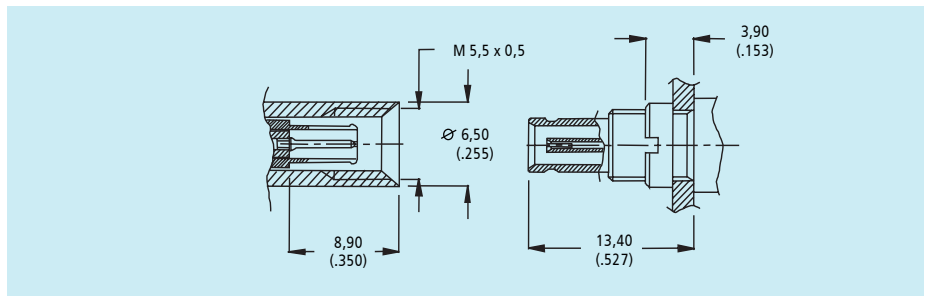

 Specification

Electrical

Impedance	50Ω / 75Ω nominal		
Frequency Range	With 50 Ω connector on 50 Ω cable = 0 - 2 Ghz With 75 Ω connector on 75 Ω cable = 0 - 2 Ghz		
Voltage Rating	At Sea level = 250 Vrms		
Insulation Resistance	1000 MΩ minimum		
Contact Resistance	Inner contact (50 Ω) = 4mΩ maximum Inner contact (75 Ω) = 6mΩ typical maximum Outer contact (50 Ω - 75 Ω) = 2.5mΩ maximum		
Reflection Coefficient (except SMD Jacks see page 12)	With 50 Ω connector on 50 Ω cable and	f = 1 GHz	= 0.05 maximum
	With 75 Ω connector on 75 Ω cable and	f = 1 GHz	= 0.1 maximum

Mechanical

Withdrawal Force, inner female contact	0.2 N (0.04 lbs.) minimum		
Withdrawal force, outer male contact	0.7 N (0.15 lbs.) minimum		
Insertion force between jacks and plugs	10 N (2.24 lbs.) maximum		
Withdrawal force between jacks and plugs	0.9 N (0.20 lbs.) minimum		
Materials	Bodies and nuts: Brass. Inner male contact: Brass or Beryllium Copper. Inner and outer female contacts: Beryllium Copper. Insulators : PTFE or Thermoplastics. Crimp ferrules: Copper alloy		
Finish/Plating	Contact surfaces: Gold over Nickel. Bodies and crimp ferrules: Nickel or Gold over Nickel.		

Environmental

Temperature Rating	-40° C to 85°C
--------------------	----------------

General

Connector Durability	500 matings minimum
Standards	CECC 22230, DIN 47297

50 Ω Cable Plugs

Straight Crimp Plug
Push-Pull Coupling
(Packed in Trays of 25)

Part Number	Cable Numbers
D55-B24-3058GDA	RG58/U
D55-B24-3060GDA	RG316/U

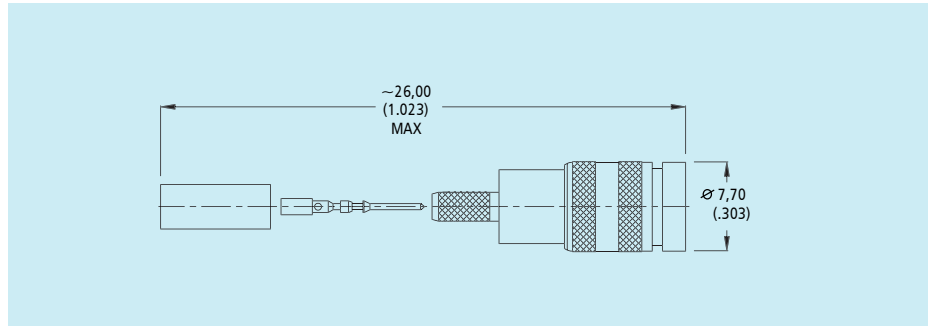

Assembly Instructions BBAI - 1289 - page 30

50 Ω Cable Jacks

Straight Crimp Bulkhead Jack
All Couplings
(Packed in Trays of 25)

Part Number	Cable Number
D51-B27-3058GEA	RG58/U
D51-B27-3060GEA	RG316/U

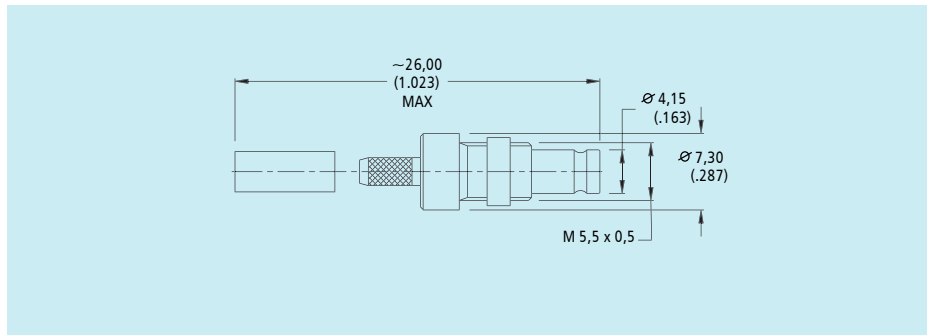

Mounting Hole Diameter 6,16 (.243) min - 6,33 (.249) max
Maximum Panel Thickness 1,50 (.059)

Assembly Instructions BBAI - 1281- page 29

50 Ω Printed Circuit Board Jacks

Straight Jack 0,95 Square Legs
Push-Pull and Snap-On Couplings
(Packed in Trays of 100)

Part Number	Cable Number
D51-B51-9002GBA	14,5 (.570)
D51-B51-9003GBA	15,5 (.610)

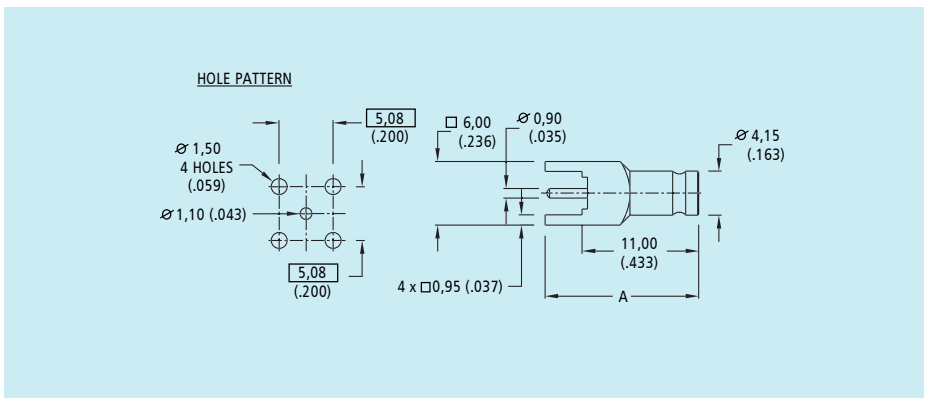

50 Ω Printed Circuit Board Jacks

Straight Bulkhead Jack
 0,95 Square Legs - All Couplings
 (Packed in Trays of 100)

Part Number
D51-B51-9001GBA

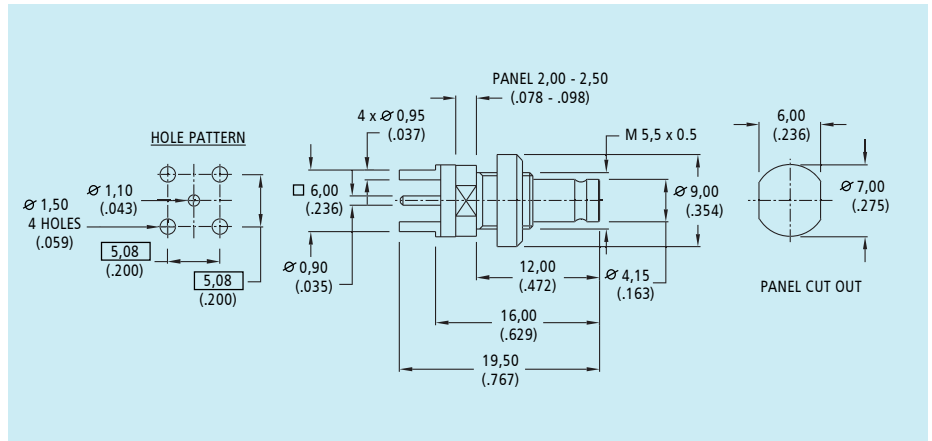

Right Angle Jack 0,95 Square Legs
 All Couplings
 (Packed in Trays of 100)

Part Number
D51-B53-9004EAA

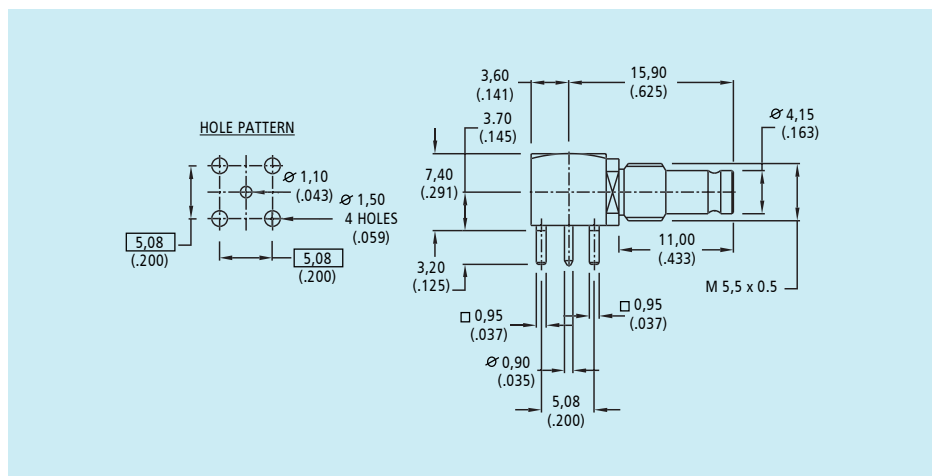

75 Ω Cable Plugs

Straight Crimp Plug
Push-Pull Coupling
(Packed in Trays of 25)

Part Number	Cable Numbers
D55-F24-3022GDA	ST212 (*)
D55-F24-3035GDA	BT3002 - TZC75024
D55-F24-3037GDA	RA7000
D55-F24-3053GDA	B 0,25/1,45
D55-F24-3054GDA	HFE2290
D55-F24-3079GDA	RG179 B/U
D55-F24-3090GDA	Flex 2
D55-F24-3091GDA	Flex 3
D55-F24-3001GDA	2YCY 0,4/2,5
D55-F24-3043GDA	2,5C - 2V
D55-F24-3095GDA	LA910

* Square Crimp optional

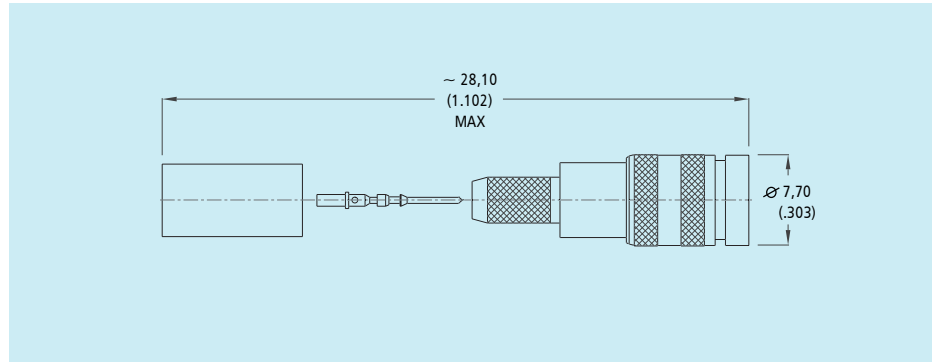

Assembly Instructions BBAI - 1269 (Indent) - page 24 - BBAI-1280 (Square*) - page 28

Part Number	Cable Numbers
D55-F24-3024GDA	ST214
D55-F24-3033GDA	BT2003
D55-F24-3036GDA	BT5000
D55-F24-3051GDA	TZC75005
D55-F24-3052GDA	0,4/2,4
D55-F24-3092GDA	Flex 5
D55-F24-3094GDA	Flex 7
D55-F24-3045GDA	3C - 2V
D55-F24-3046GDA	3C - 2W

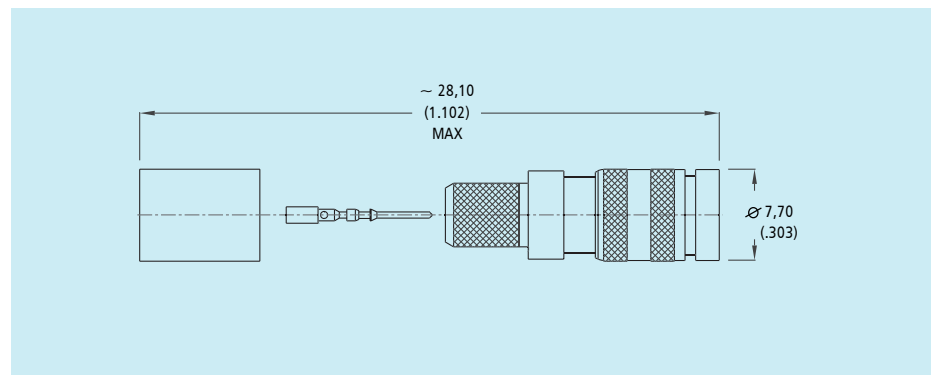

Assembly Instructions BBAI - 1269 - page 24

Right Angle Solder Crimp Plug
Push-Pull Coupling - Screw Cap
(Packed in Trays of 25)

Part Number	Cable Numbers
D55-F28-3122A9A	ST212
D55-F28-3124A9A	ST214
D55-F28-3133A9A	BT2003
D55-F28-3135A9A	BT3002 - TZC75024
D55-F28-3136A9A	BT5000
D55-F28-3137A9A	RA7000
D55-F28-3179A9A	RG179

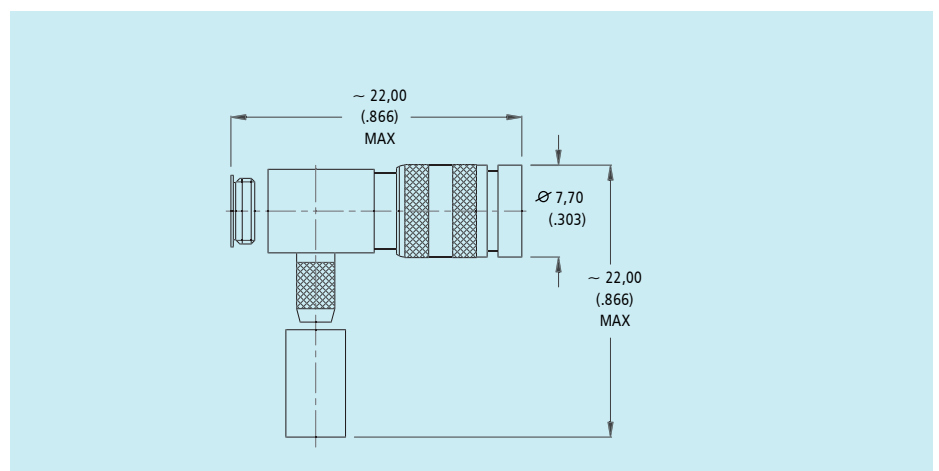

Assembly Instructions BBAI - 1277 - page 27



75 Ω Plugs

The Type 54 range of connectors has been developed by ITT Industries, Cannon in conjunction with British Telecom. The Type 54 connector is a hybrid version of the 1.0/2.3 connector that is used extensively in Telecom systems in certain parts of Europe and the USA.

The 1.0/2.3 connector interface is now being offered by a number of Telecom equipment manufacturers because of its smaller size and the obvious benefits from higher density it offers, when compared with the 1.6/5.6 & Type 43 (SMZ) ranges.

The Type 54 connector combines the 1.0/2.3 interface and locking system with the termination methods and benefits of the Type 43 (SMZ) connector. This enables the UK installation market to use the Type 54 connector without having to re-equip and re-train installers.

The Type 54 range has the standard 1.0/2.3 interface according to CECC 22230 & DIN 47297.



75 Ω Plugs

Straight Crimp Plug
Push-Pull Coupling
(Packed in Trays of 25)

Part Number	Cable Numbers
D55-F24-3133GDA	BT2003
D55-F24-3135GDA	BT3002
D55-F24-3136GDA	BT5000
D55-F24-3137GDA	RA7000
D55-F24-3138GDA	RA8000

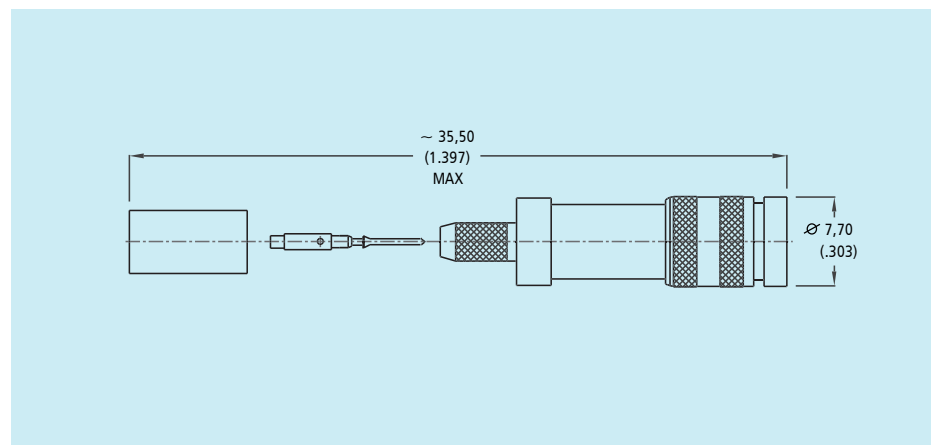

Assembly Instructions BBAI - 1265 - page 23

Right Angle Crimp Plug
Push-Pull Coupling - Press-In Cap
(Packed in Trays of 25)

Part Number	Cable Numbers
D55-F28-3233A9A	BT2003
D55-F28-3235A9A	BT3002
D55-F28-3236A9A	BT5000
D55-F28-3237A9A	RA7000
D55-F28-3238A9A	RA8000

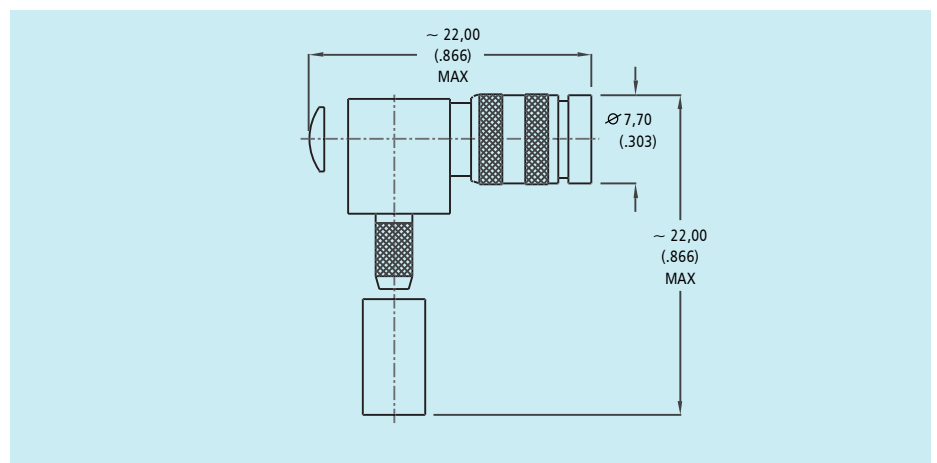

Assembly Instructions BBAI - 1276 - page 25 + 26

75 Ω Cable Jacks

Straight Bulkhead Crimp Jack
 All Couplings
 (Packed in Trays of 25)

Part Number	Cable Numbers
D55-F27-3022GEA	ST212
D55-F27-3024GEA	ST214
D55-F27-3033GEA	BT2003
D55-F27-3035GEA	BT3002
D55-F27-3036GEA	BT5000
D55-F27-3037GEA	RA7000
D55-F27-3051GEA	TZC75005
D55-F27-3052GEA	0,4/2,4
D55-F27-3053GEA	B 0,25/1,45
D55-F27-3054GEA	HFE2290
D55-F27-3079GEA	RG179 B/U
D55-F27-3090GEA	Flex 2
D55-F27-3091GEA	Flex 3
D55-F27-3092GEA	Flex 5
D55-F27-3094GEA	Flex 7
D55-F27-3095GEA	LA 910
D55-F27-3043GEA	2.5C - 2V
D55-F27-3045GEA	3C - 2V
D55-F27-3046GEA	3C - 2W

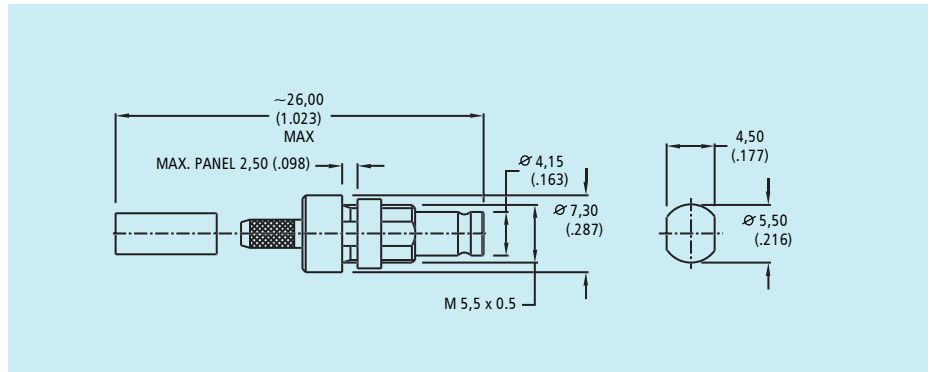

Assembly Instructions BBAI - 1281 - page 29

Right Angle Bulkhead Solder Crimp Jack
 All Couplings - Screw Cap
 (Packed in Trays of 25)

Part Number	Cable Numbers
D51-F30-3035GBA	BT3002
D51-F30-3022GBA	ST212
D51-F30-3024GBA	ST214
D51-F30-3069GBA	RG179 B/U
D51-F30-3059GBA	RG59
D51-F30-3090GBA	Flex 2
D51-F30-3091GBA	Flex 3

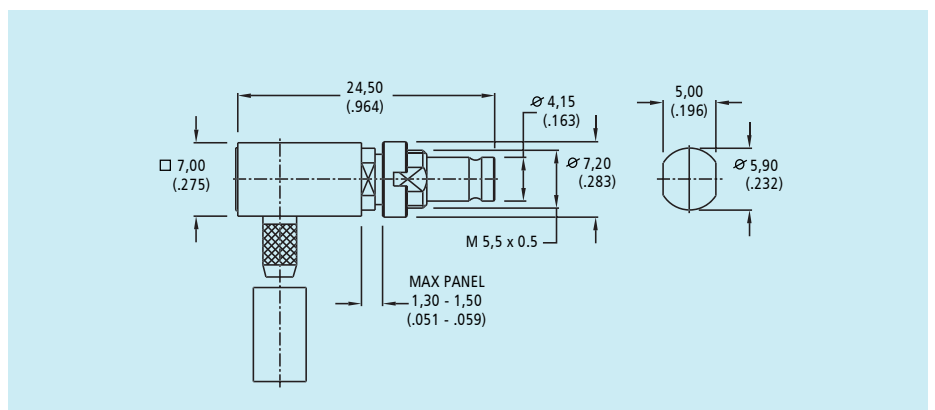

Assembly Instructions BBAI - 1277 - page 27



75 Ω Printed Circuit Board Jacks

Straight Jack 0,95 Square Legs
Push-Pull and Snap Couplings
(Packed in Trays of 100)

Part Number	A
D51-F51-9002GBA	14,5 (.571)
D51-F51-9003GBA	15,5 (.610)

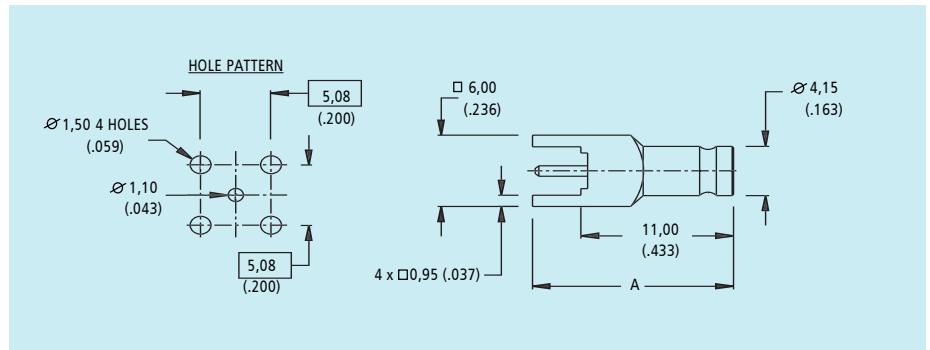

Straight Bulkhead Jack 0,95 Square Legs
All Couplings
(Packed in Trays of 100)

Part Number
D51-F51-9006GBA

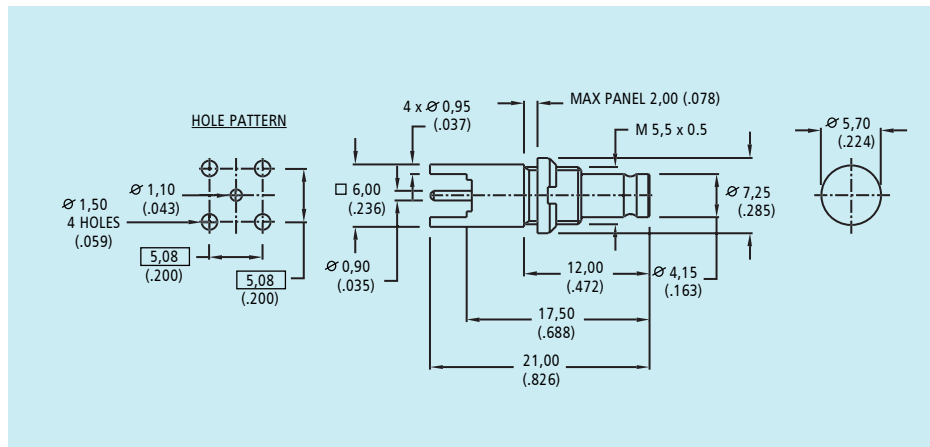

Straight Jack 0,80 Square Legs
All Couplings

Part Number
D51-F51-9001GBA

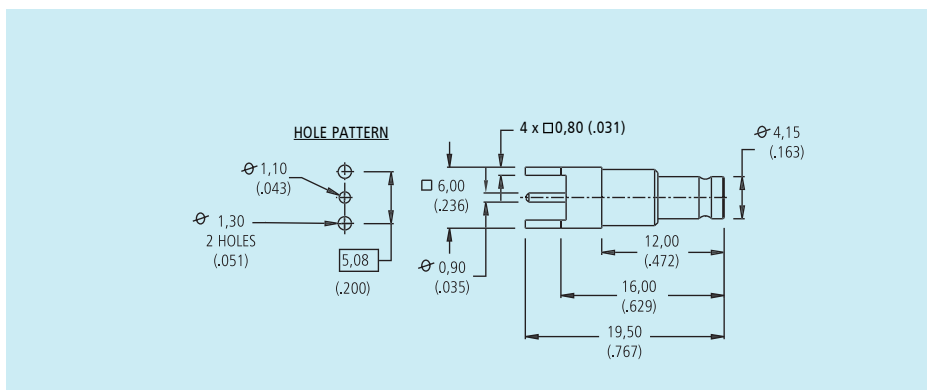

75 Ω Printed Circuit Board Jacks

Right Angle Jack
All Couplings
(Packed in Trays of 100)

Part Number
D51-F53-9004GBA

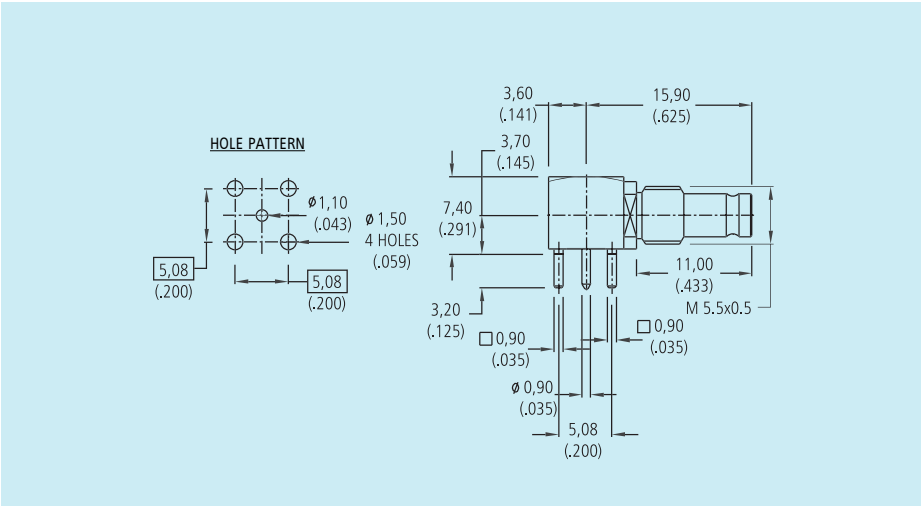

Description

ITT Industries, Cannon can now offer a range of surface mount coaxial connectors developed to suit the requirements of modern interconnect systems. Currently being produced with the emerging standard, 1.0/2.3 75Ω interface for telecommunication equipments, these new connectors can be used in fully automated production processes.

Featuring the new MID plated plastic bodies, these new connectors are constructed in modules comprising 2, 3 or 4 ports. The modules are light in weight, enabling them to be handled by suction pick and place, and because all PCB contact pads are formed as part of the moulding, exceptional coplanarity can be assured.

The provision for additional mechanical fixing of the connector, through the PCB by rivet or screw is included, which will increase the connector to board retention. With this additional fixing, a total axial force of 150N per port can be applied.

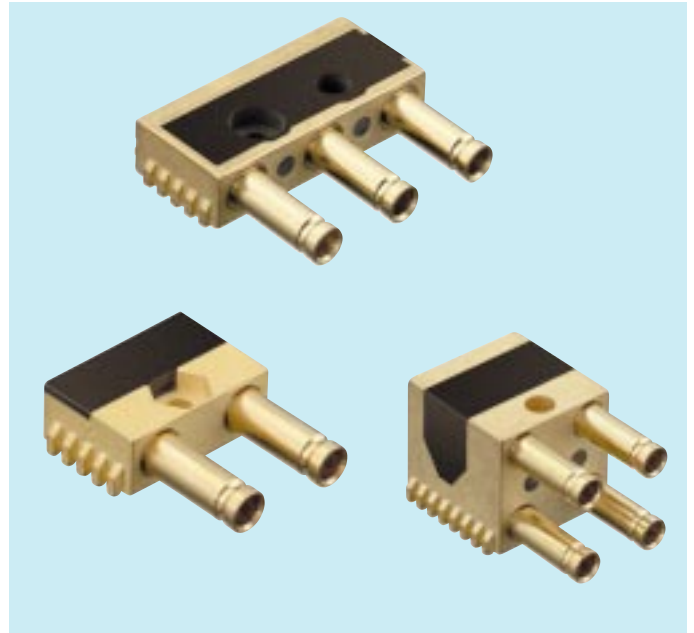

Features

- 2,3 or 4 port configurations
- 1.0/2.3 jack interface
- Coplanarity of +/- 0.05mm
- Flat top for suction pick-up
- Light weight (2 port < 5g, 4 port < 13g)
- Tape and reel packed
- Resistant to normal soldering temperatures
- Resistant to most PCB cleaning processes
- Common Grounds

Specification

- 75 ohm nominal impedance
- Interface to CECC 22230 & DIN 47247
- Reflection factor: $r = 0.1$ up to 500 MHz
- Inner contact resistance : <20m ohm
- Outer contact resistance : <30m ohm
- Proof voltage: 750 Vrms
- Connector to board solder retention : 3N/mm²

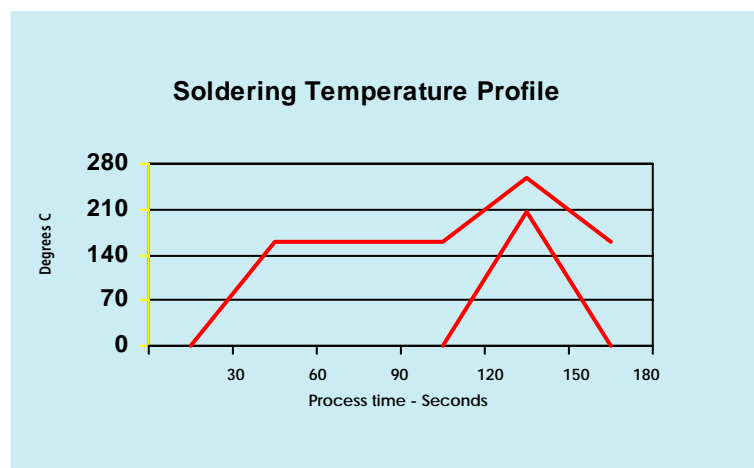

75 Ω MID Surface Mount Jacks

2 Way Coaxial Module

Part Number
051-F53-9029A9H
(Packed in Reels of 400)

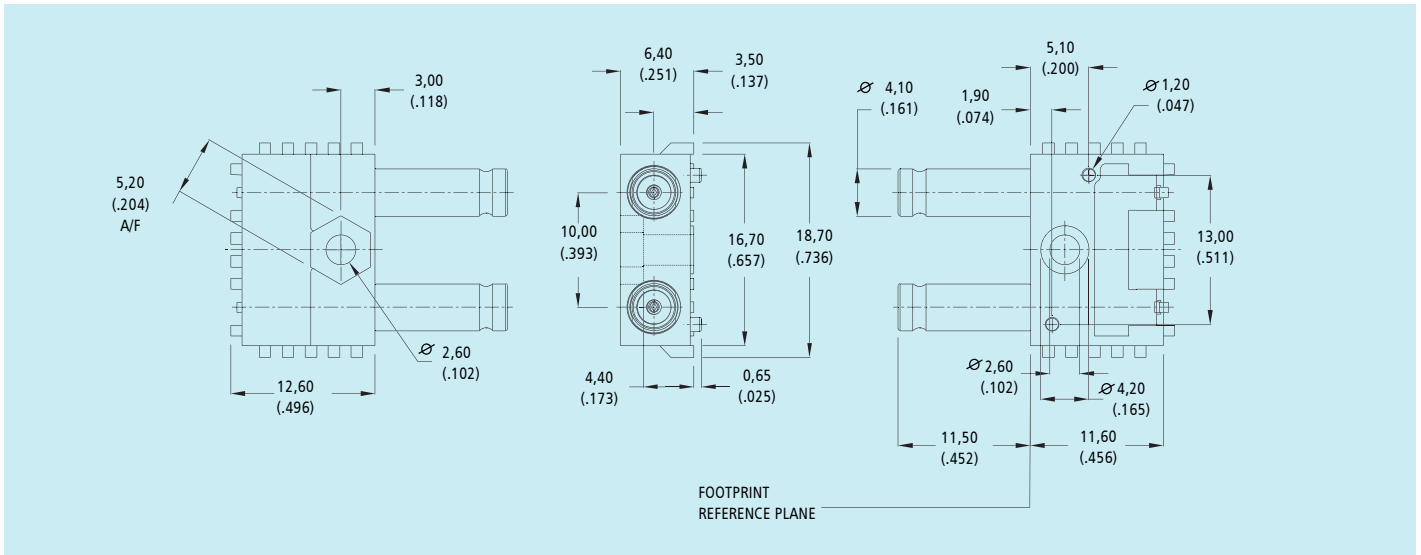

3 Way Coaxial Module

Part Number
051-F53-9069A9H
(Packed in Reels of 300)

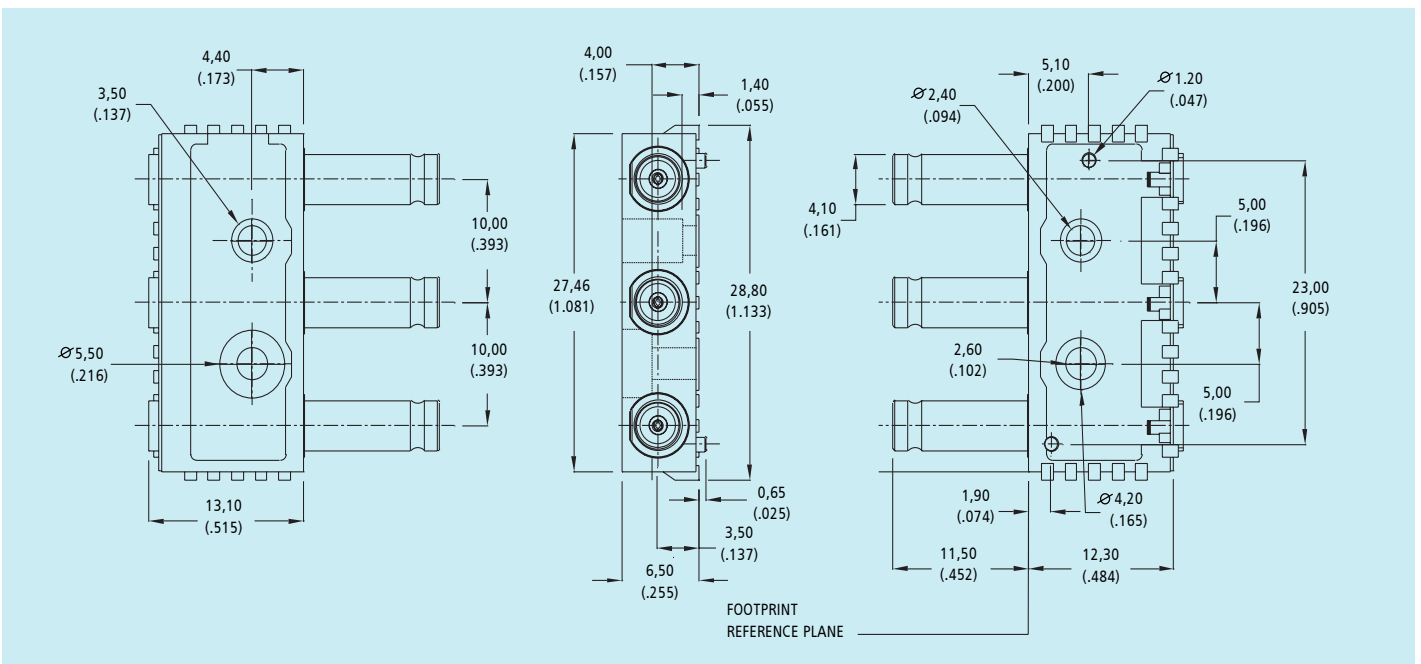

75 MID Surface Mount Jacks

4 Way Coaxial Module

Part Number
051-F53-9019A9H
(Packed on Reels of 100)

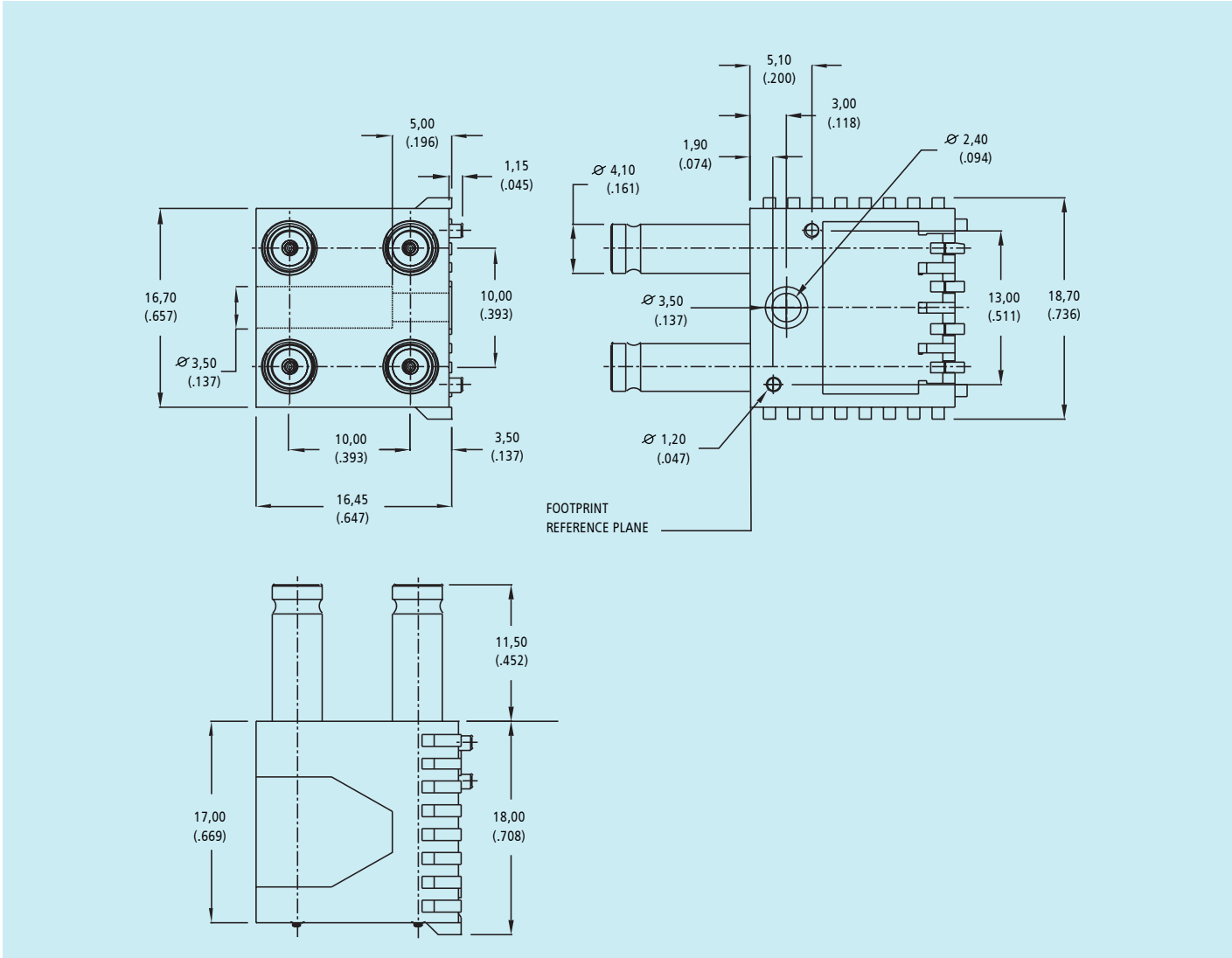

Footprints

CONNECTOR FOOTPRINT

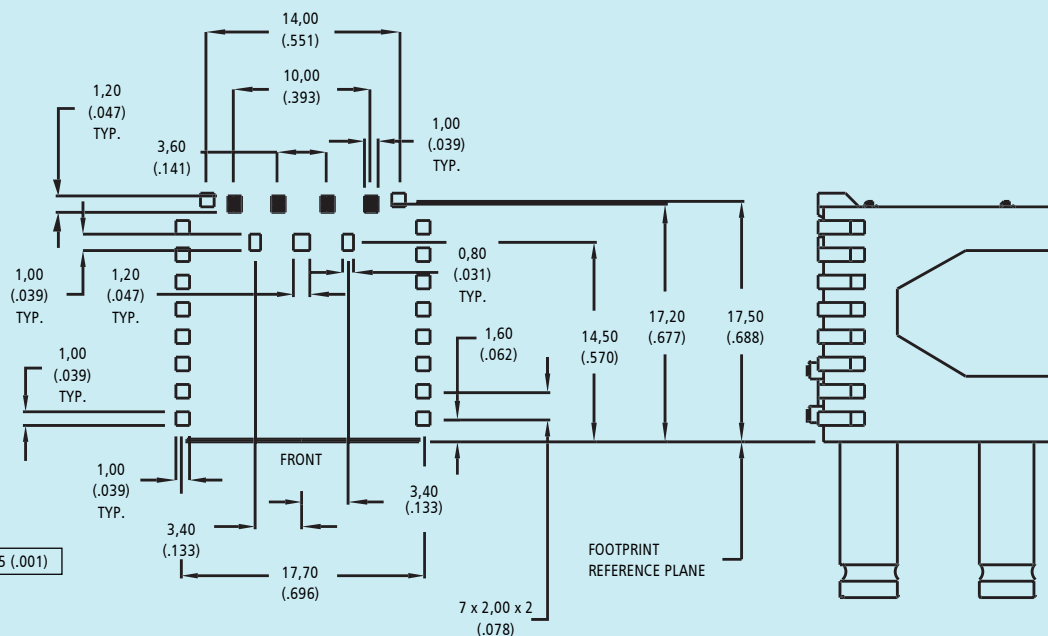
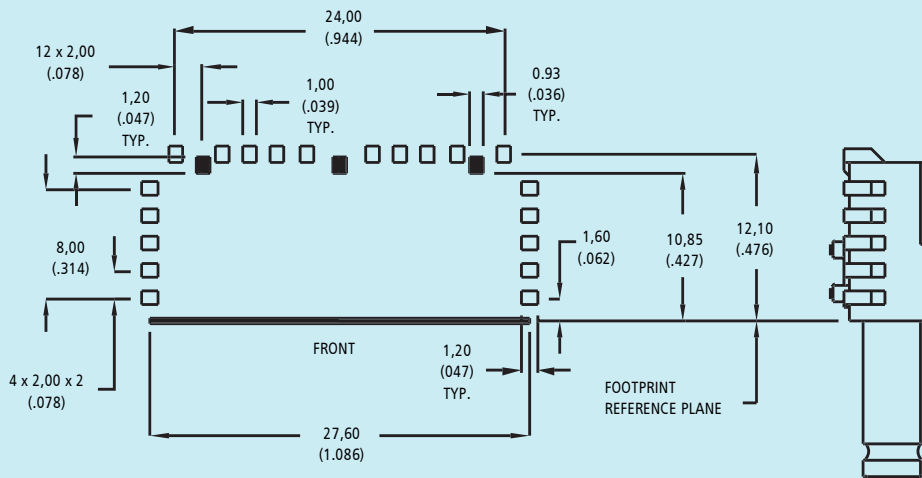
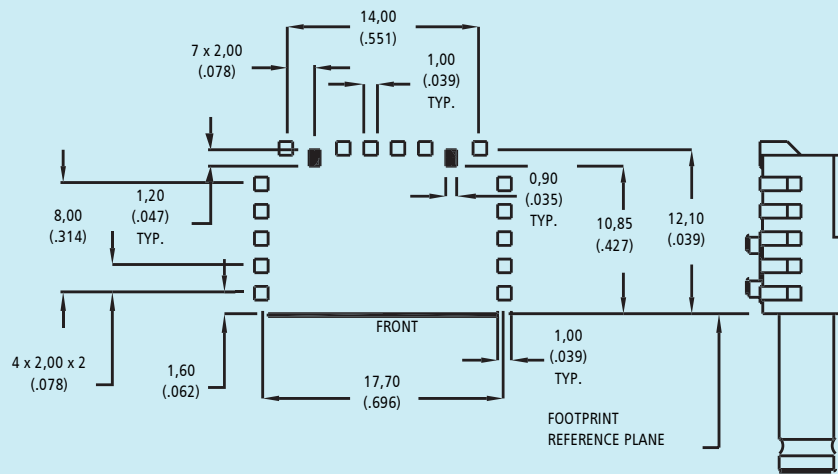

NOTE:
 - PITCH CONCENTRICITY \oplus 0,05 (.001)
 - SIGNAL FEET ARE SHADED

Telecom Balun

The ITT Industries, Cannon 1.0/2.3 Telecom Balun, for use in ITU G.703 applications, converts between a 120 ohm twisted pair and a 75 ohm coaxial transmission line.

This connector has a 1.0/2.3 Push-Pull plug interface with the transformer built into the body, it can be quickly connected to screened or unshielded twisted pair cables through IDC terminations, using a simple assembly tool. The small size allows these connectors to be mounted on a pitch of 10 mm.

This balun is ideal for use where it is necessary to interconnect an equipment with 75 ohm coaxial outputs to a 120 ohm cable distribution system. The balun is only a little larger than the connector that it would replace.

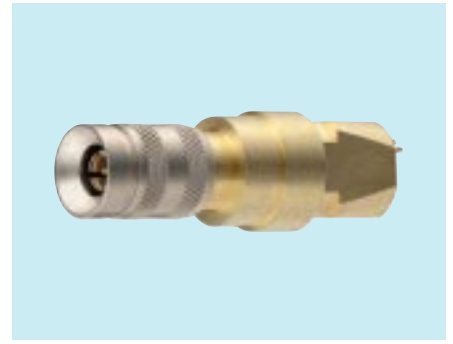

Features

- 1.0/2.3 Push-Pull plug coupling
- Quick and simple termination procedure
- Small size
- Meets G.703 standards

Specifications

- | | |
|------------------------------------|---|
| • Push-Pull plug Interface - | CECC 222 30 |
| • Nominal Impedance - | Coaxial 75 ohm
Twisted Pair 120 ohm |
| • Frequency range - | 50 kHz - 10MHz |
| • Return loss 75 ohm and 120 ohm - | 51 - 102 kHz >18 dB
102 - 2048 kHz >25 dB
2048 - 3072 kHz >23 dB
3072 - 10000 kHz >16 dB |
| • Wire size - | Conductor 0.5 mm copper
Insulation 1.4 mm |

Circuit Diagram:

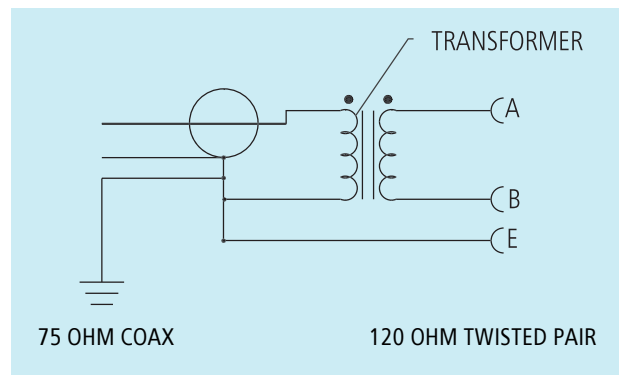

Plug Balun

Part Number
055-F24-9019A9G
(Packed in Trays of 16)

Please contact Cannon for assembly instructions

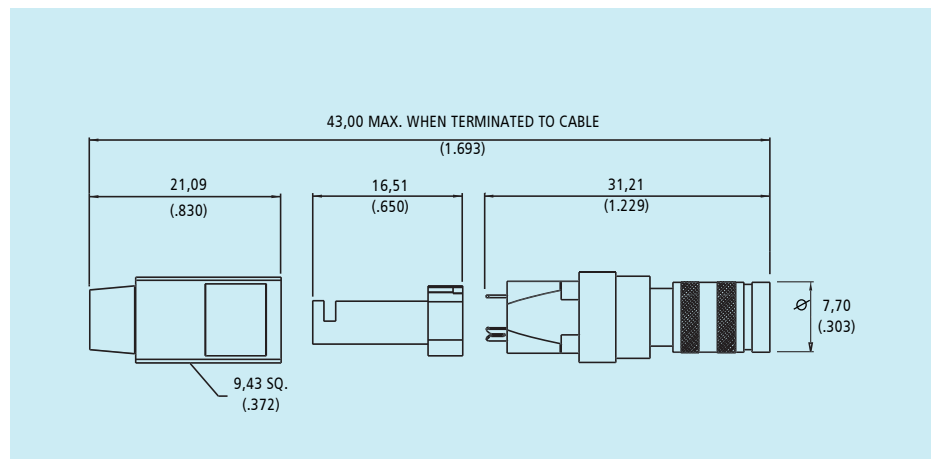

75 Ω U - Link

Plug to Plug U - Link
Screw and Push - Pull Couplings

- Available on request

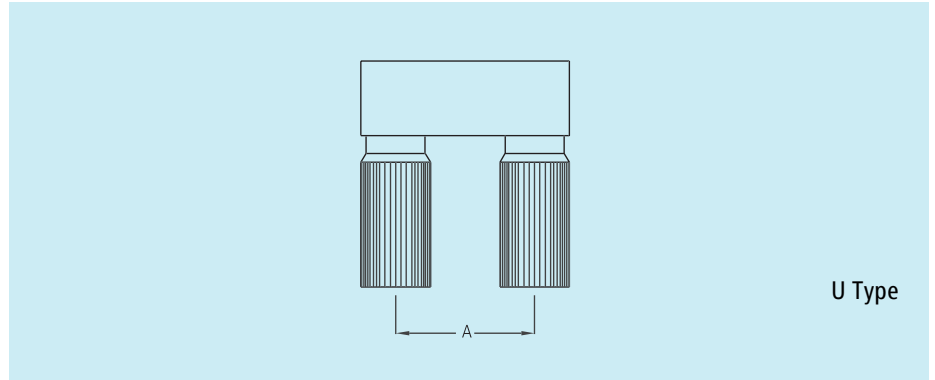

75 Ω Monitor Points

We can produce different types of Monitor Points: standard, decoupled and adapted on request.

They are available in different styles: T, TL and Y.

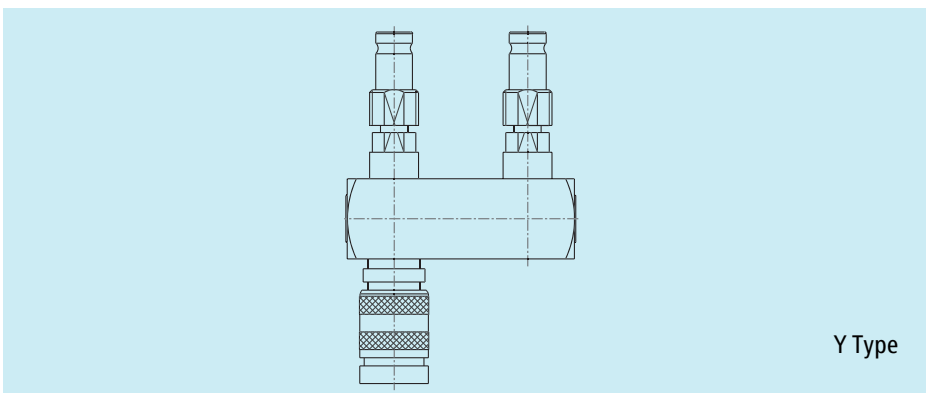
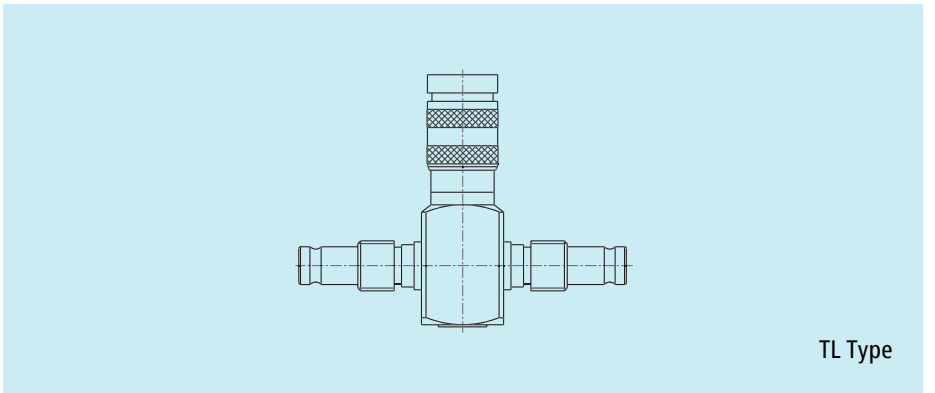
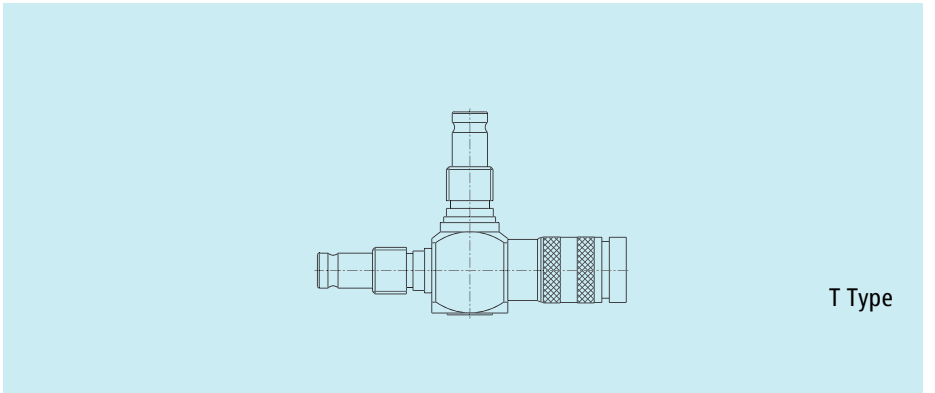

1.0/2.3 In-Series Adaptors

1.0/2.3 Push-Pull Plug to Push-Pull Plug

Part Number
D55-F73-0000A9A

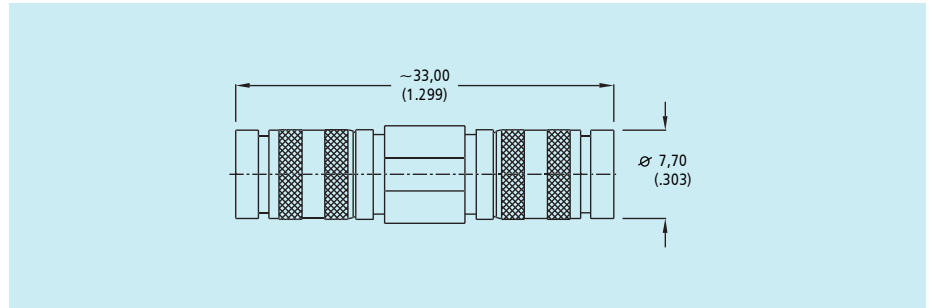

1.0/2.3 Push-Pull Plug to Jack

Part Number
D55-F74-0000A9A

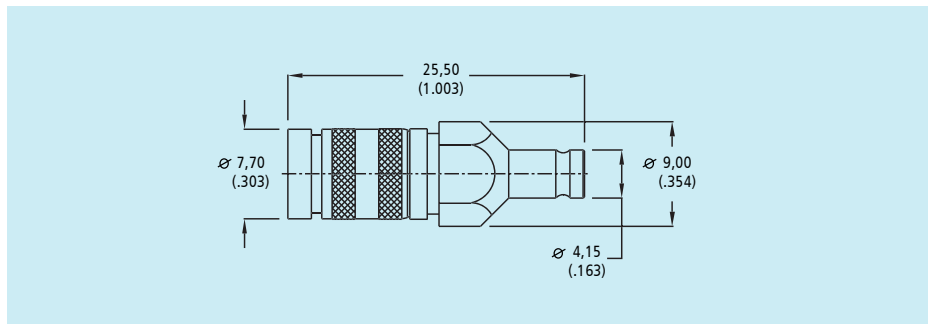

1.0/2.3 Jack to Bulkhead Jack

Part Number
D55-F77-0000A9A

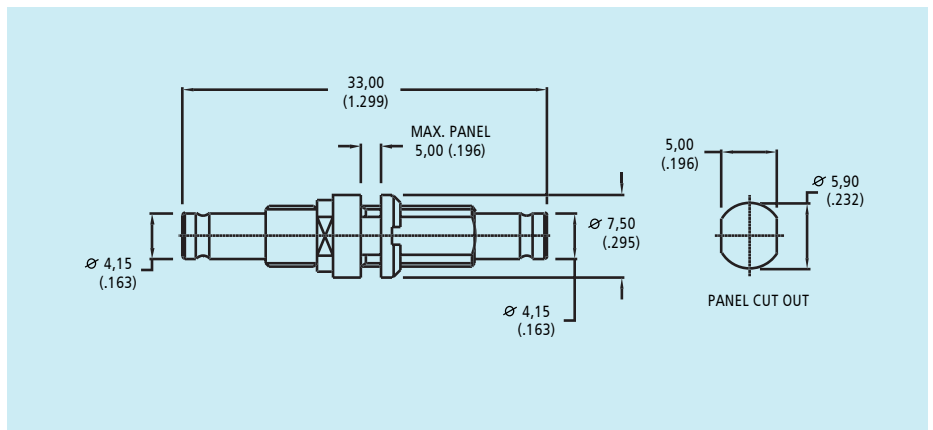

1.0/2.3 To 1.6/5.6 Between Series Adaptors

1.0/2.3 Push-Pull Plug To 1.6/5.6 Plug

Part Number
D55-F73-6000A9A

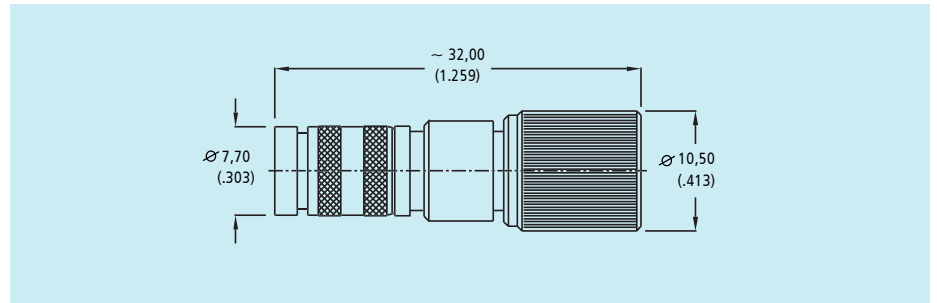

1.0/2.3 Push-Pull Plug To 1.6/5.6 Jack

Part Number
D55-F74-6000A9A

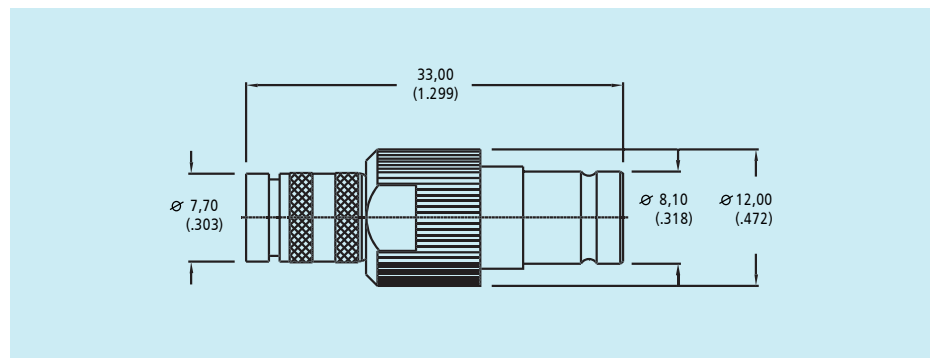

1.0/2.3 Jack To 1.6/5.6 Plug

Part Number
D55-F74-6010A9A

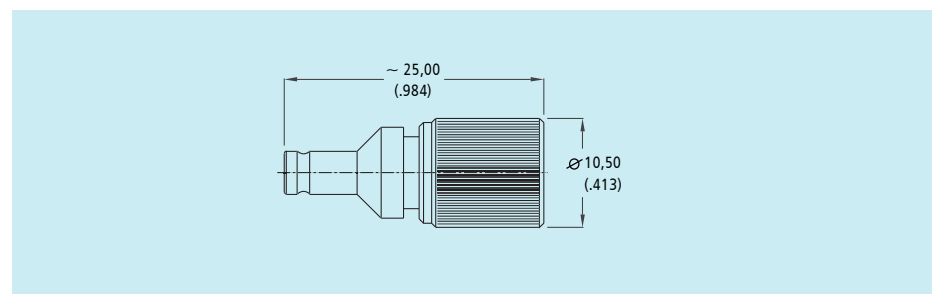

1.0/2.3 Jack To 1.6/5.6 Jack

Part Number
D55-F72-6000A9A

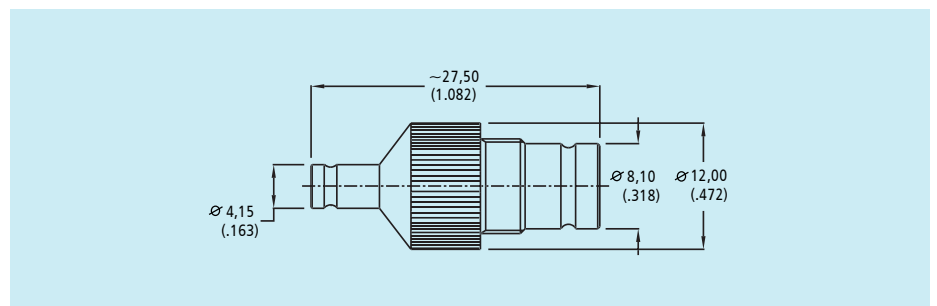

1.0/2.3 To BNC Between Series Adaptors

1.0/2.3 Push-Pull Plug To BNC Jack

Part Number
D55-F74-6002A9A

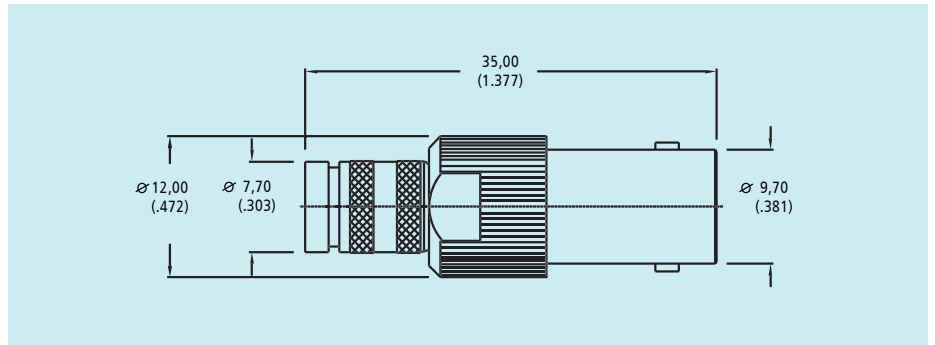

1.0/2.3 Jack To BNC Plug

Part Number
D55-F74-6012A9A

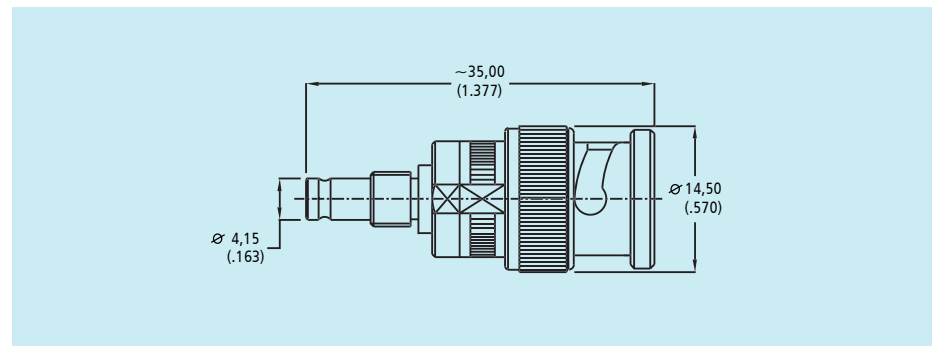

1.0/2.3 Jack To BNC Jack

Part Number
D55-F72-6002A9A

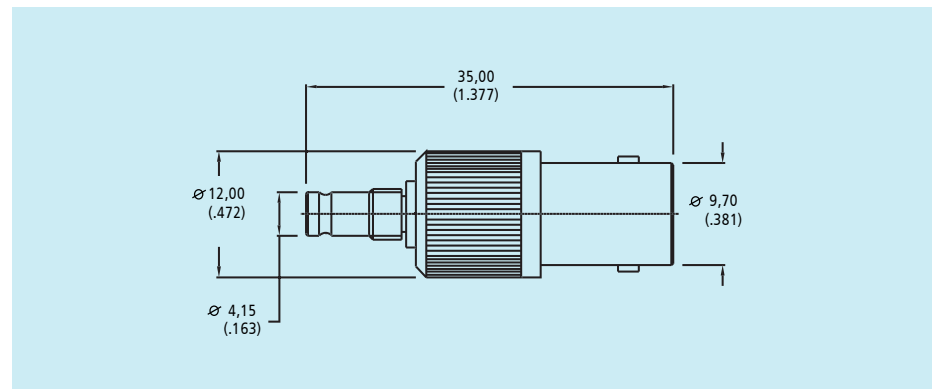

75 Ω Terminations

Termination Plug 1/8W
Push-Pull Coupling

Part Number
D65-F01-0000A9A

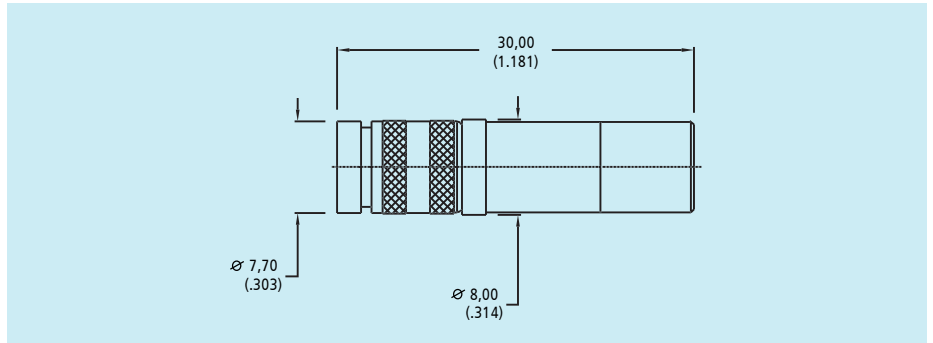

Termination Jack 1/8W
All Couplings

Part Number
D65-F02-0000A9A

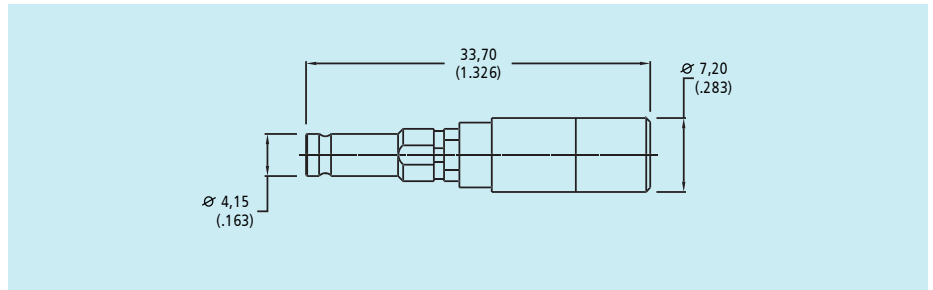

75 Ω Attenuators

1.0/2.3 Push-Pull Plug 1.0/2.3 Jack 20 dB

Part Number
D65-F74-0020A9A

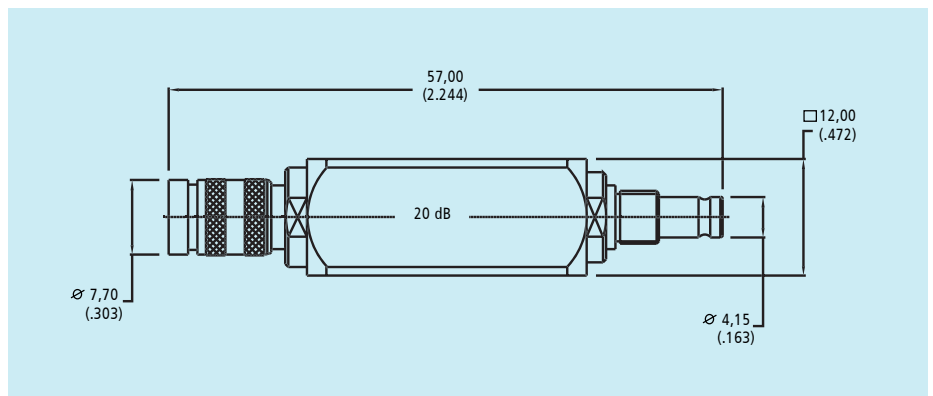

1.0/2.3 Push-Pull Plug 1.6/5.6 Jack 20 dB

Part Number
D65-F74-6020A9A

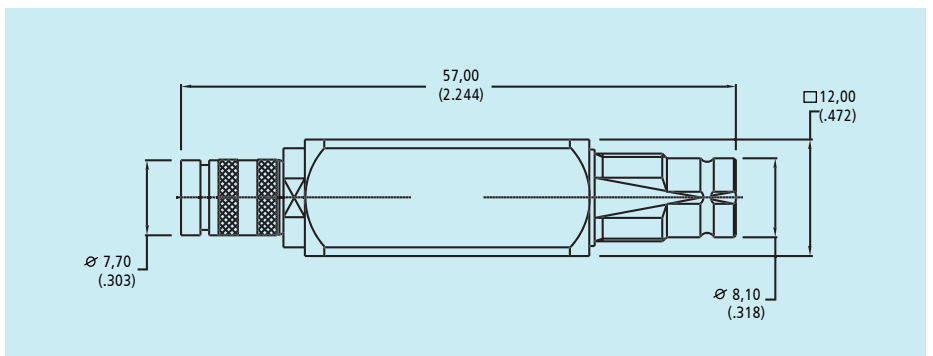

Tooling

Extraction tool for Straight and Right Angle Push-Pull Plugs

Part Number
T4869

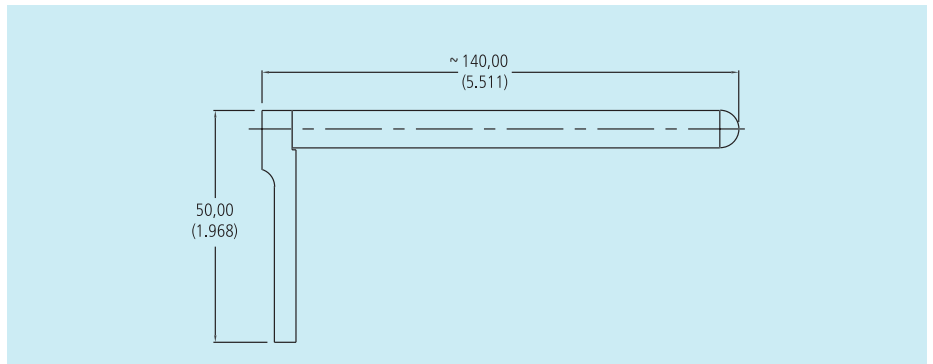
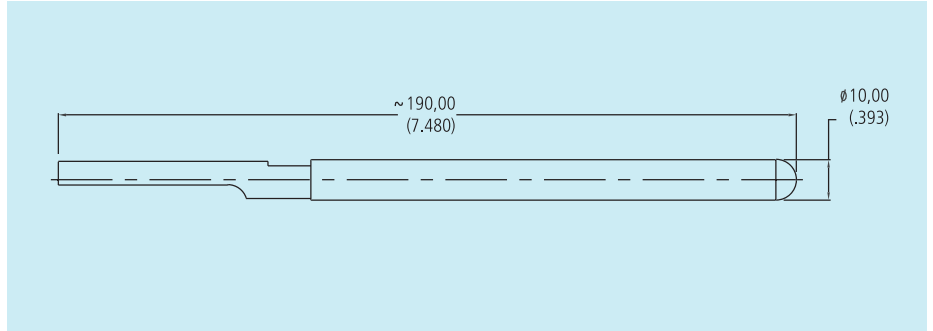

Extraction tool for Straight and Right Angle Push-Pull Plugs

Part Number
T4839

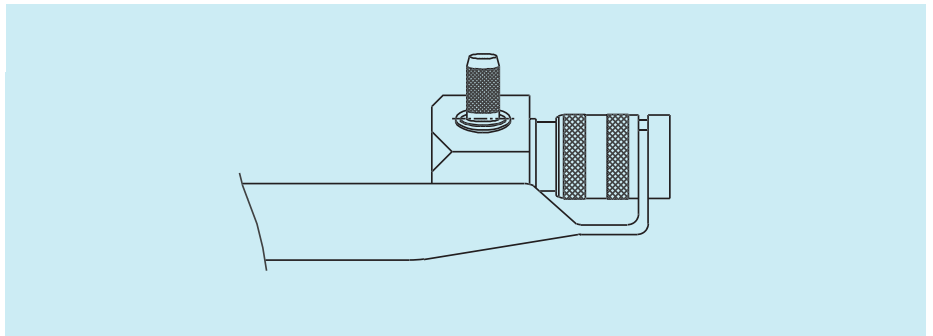

Screw tool for Bulkhead Jacks

Part Number
T4882

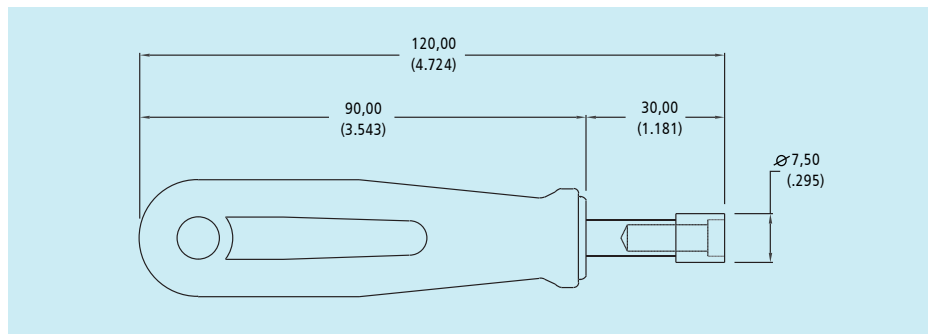

RF Coaxial Connectors

Assembly Instructions

BBAI NO.: 1265 Type 43 (SMZ) single body and Type 54 straight

Tools Required:	Locator: T4841 and T4881 (5000 cable only)	Crimp Tool: T4519
-----------------	--	-------------------

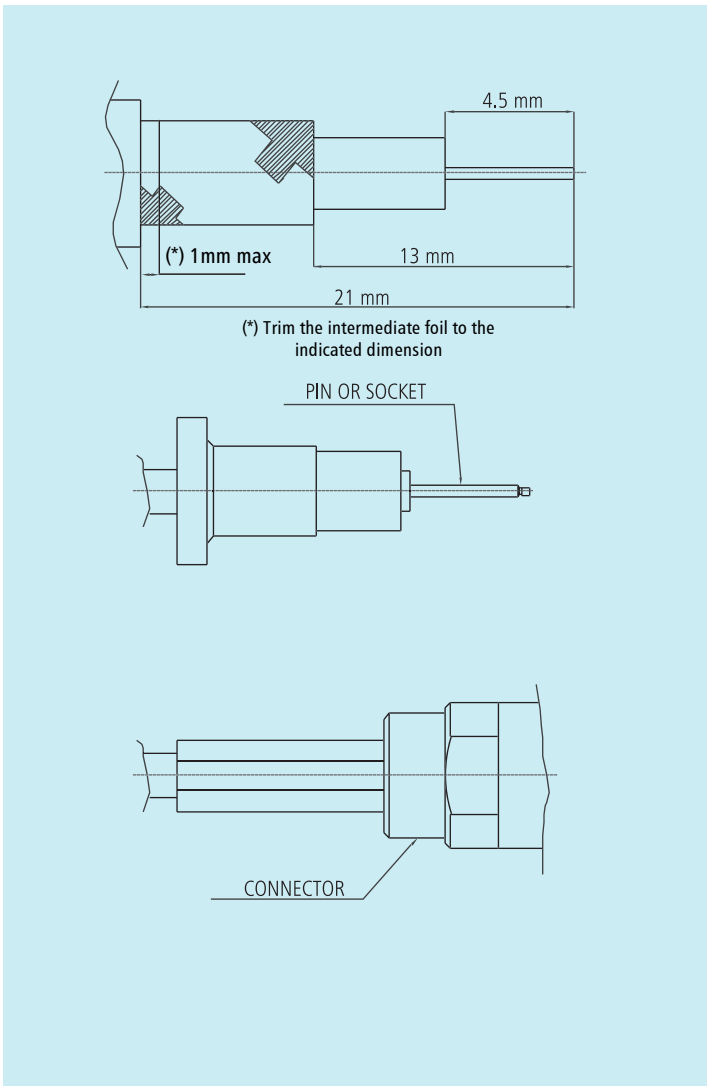
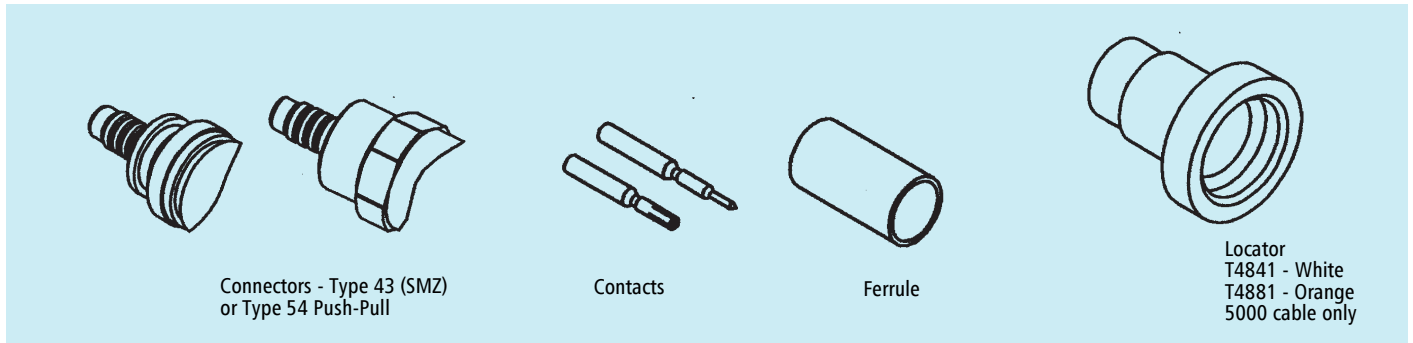

1. Strip the cable to the dimensions shown taking care not to damage the braid, dielectric or inner conductor.

NOTE:

For RA7000 and 5000 cable, leave the foil in place over the dielectric.

2. Insert the cable centre conductor into the back of the contact. Ensure the dielectric butts against the contact. Insert the cable/contact into the locator and load to the crimp tool (T4519).

Crimp the contact to the cable. Ensure that the cable is visible through the Contact Inspection Hole.

3. Slide the ferrule over the cable. Insert the cable/contact assembly into the tubular extension of the body, gently twisting and rocking the connector body to spread the braid will help.

The contact will snap into position in the connector. Slide the ferrule over the braid and crimp using tool no. T1025/- fitted with the appropriate die set (see table below).

cable	across flats dim.	die set no.
2001	4.52 mm	T1025/5
2002	5.18 mm	T1025/6
2003	6.81 mm	T1025/8
RD179B/U	3.84 mm	T1025/9
5000	8.23 mm	T1025/17

cable	across flats dim.	die set no.
RG179B/U	3.25 mm	K29263
TZC75024	4.52 mm	T1025/5
3002	4.52 mm	T1025/5
RA7000	5.18 mm	T1025/6

RF Coaxial Connectors

Assembly Instructions

BBAI NO.: 1269 1.0/2.3 full - crimp/solder - crimp straight plugs

Tools Required:

Locator: T4852

Crimp Tool: see table

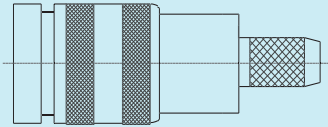

BODY ASSEMBLY

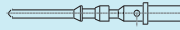

INNER MALE CONTACT



FERRULE

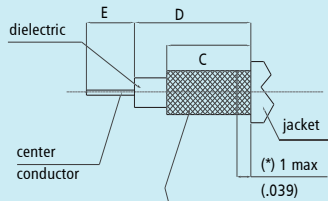

(* Trim the intermediate foil to the indicated dimension

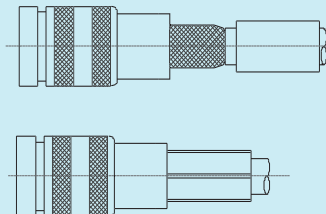
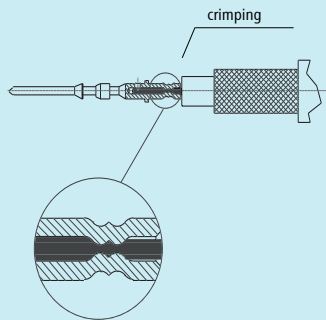

1. Prepare cable to the dimensions shown, being careful not to damage the braid, dielectric, foil or inner conductor.

Stripping Detail	C $+0.00 (+.000)$ $-0.50 (-.019)$	D $+0.00 (+.000)$ $-0.30 (-.012)$	E $+0.00 (+.000)$ $-0.20 (-.008)$
A	6.00 (.236)	8.30 (.327)	3.50 (.138)
B	8.00 (.315)	10.50 (.413)	3.50 (.138)

For cables with a foil under the braid, spread braid and trim back to dimension shown. Except RA 7000 cable where the foil should be left in place over the dielectric.

2. Crimp contact onto inner conductor using a M22520/2-01 (Cannon part number 995-0001-584) set to the selector number shown in the table below, fitted with positioner T4852.

Ensure that the conductor is visible through the inspection hole in the side of the contact.

This contact may also be soldered.

3. Place the crimp ferrule over the cable sheath.

4. Fit the connector body onto the cable/conductor so that the rear body slides between the dielectric and braid (gently twisting and rocking the connector body to spread the braids will help). Push home until a click is felt.

5. Slide the crimp ferrule forward, over the braid until it butts against the rear of the connector. Crimp using Cannon crimp tool T1025/- fitted with a suitable die set (see table).

Cable Type	Stripping Detail	Selector Setting	Die Size	Die Part Number
A (0.4/2.4)	B	3	5.4 (.213)	K29265
B (0.25/1.45)	A	3	3.25 (.128)	K29263
BT2003	B	4	6.8 (.268)	T1025/8
BT3002	A	3	4.3 (.170)	T1025/36
FLEX 2	A	3	3.25 (.128)	K29263
RG179B/U	A	3	3.25 (.128)	K29263
ST212	A	3	3.8 (.151)	T1025/9
ST214	B	4	6.8 (.268)	T1025/8
TZC75005	B	4	6.5 (.255)	T1025/11
RA7000	B	4	5.18 (.204)	T1025/6
RD179	A	3	3.84 (.151)	T1025/9

Tools Required:	Locator: -	Crimp Tool: see instruction 5
-----------------	------------	-------------------------------

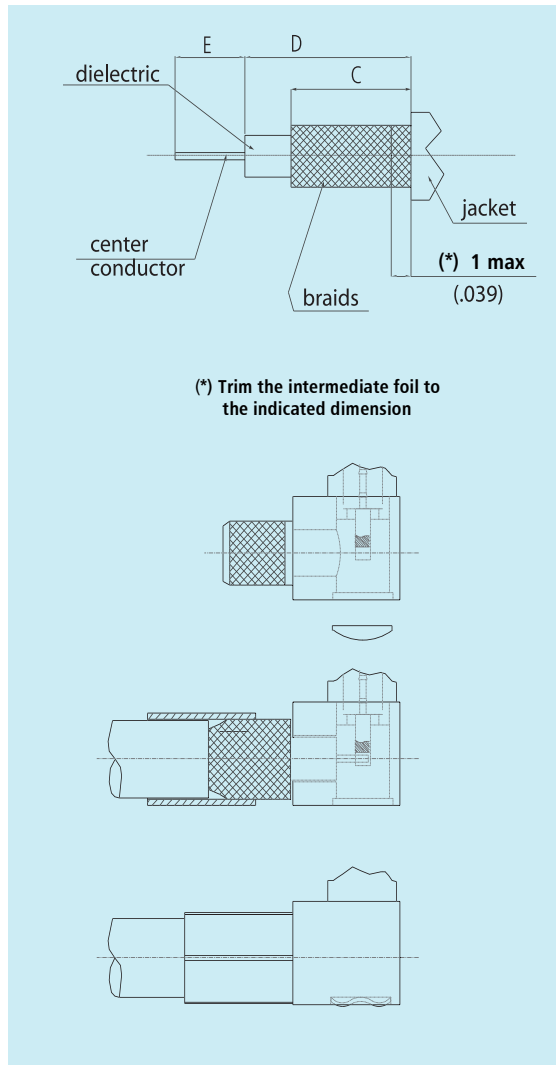
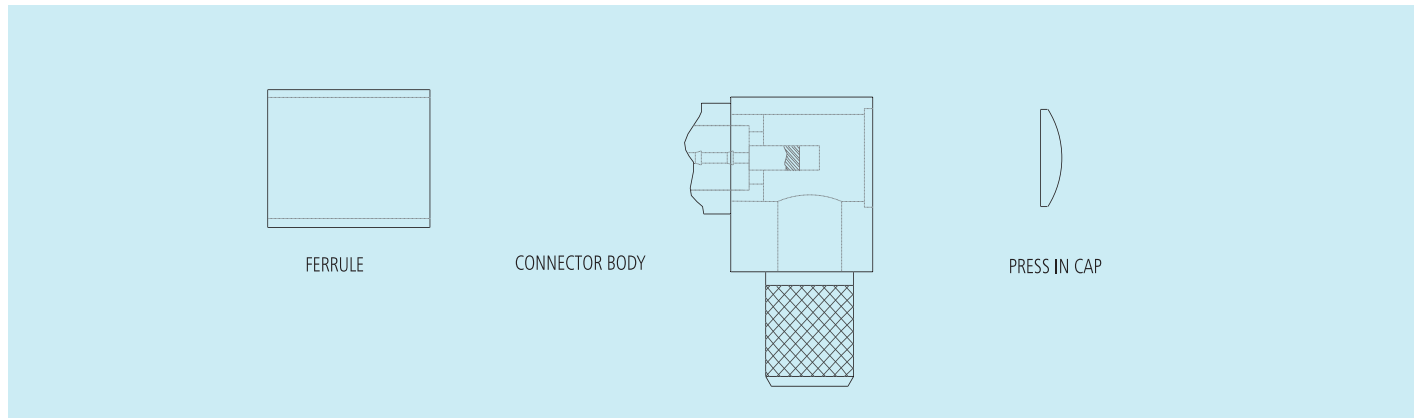

1. Trim cable to the dimensions shown, being careful not to damage the braid, dielectric, foil or inner conductor.

Stripping Detail	C $+0.00 (+.000)$ $-0.50 (-.019)$	D $+0.20 (+.008)$ $-0.00 (-.000)$	E $+0.00 (+.000)$ $-0.20 (-.008)$
A	6.00 (.236)	7.00 (.276)	3.00 (.118)

For cables with a foil under the braid, spread braid and trim back to dimensions shown. The foil should be left in place over the dielectric, except for RA 7000 and 5000 cable, where the foil should be left in place over the dielectric.

2. If fitted, remove the cap from the body of the connector.

3. Place the crimp ferrule over the cable sheath.

4. Fit the connector body onto the cable/conductor so that the rear body slides between the dielectric and braid (gently twisting and rocking the connector body to spread the braids will help) and ensure that the conductor fits into the slot in the rear of the contact.

5. Slide the crimp ferrule forward, over the braid until it butts against the rear of the connector. Crimp using Cannon crimp tool T1025/- fitted with a suitable die set (see table).

Cable Type	Stripping Detail	Die Size	Die Part Number
BT 3002	A	4.52 (.178)	T1025/5
BT 2003	A	6.81 (.268)	T1025/8
BT 5000	A	8.23 (.324)	T1025/17
RA 7000	A	5.18 (.204)	T1025/6

6. Solder the conductor to the contact and press in the cap using Cannon tool T2921 equipped with the tool adaptor T4872 and with the bolt adaptor T4880 (see next page).

Tools Required:	Locator: -	Crimp Tool: see instruction 5
-----------------	------------	-------------------------------

**CannonTool
T2921**

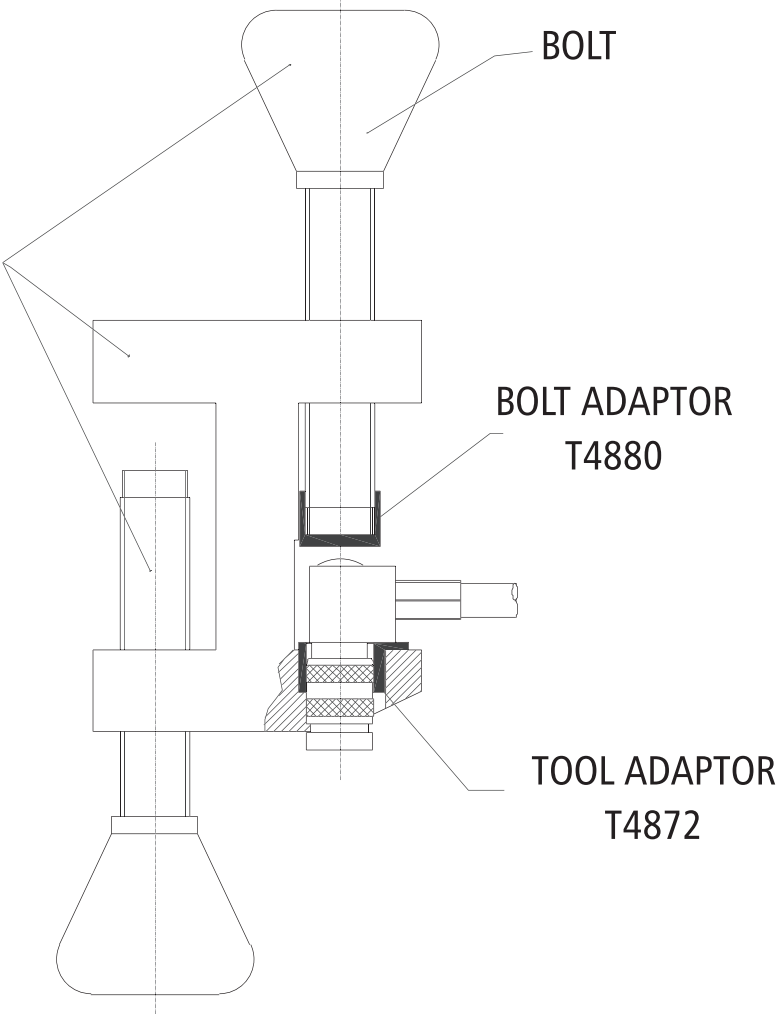

RF Coaxial Connectors

Assembly Instructions

BBAI NO.: 1277 1.0/2.3 Solder - crimp right angle plug

Tools Required:	Locator: -	Crimp Tool: see instruction 5
-----------------	------------	-------------------------------

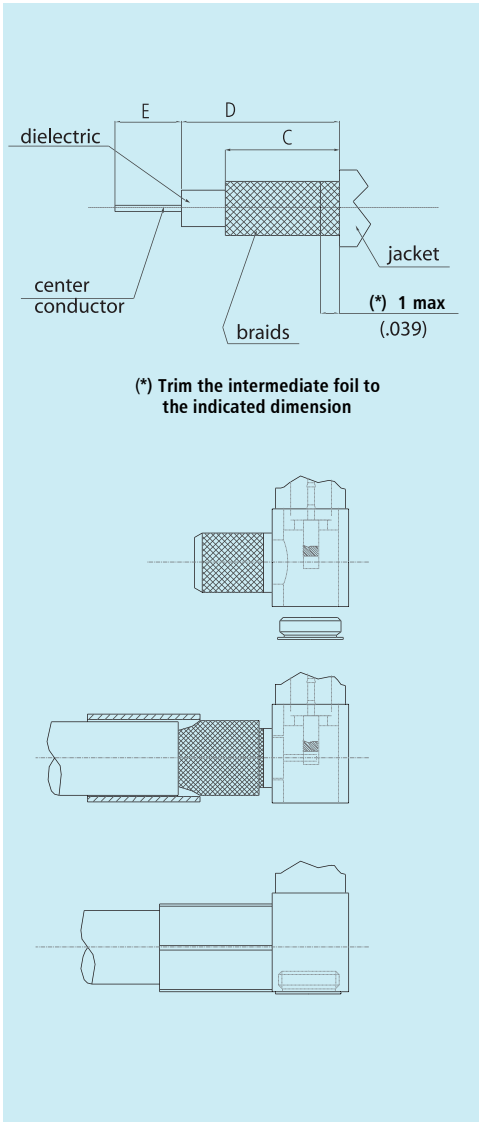
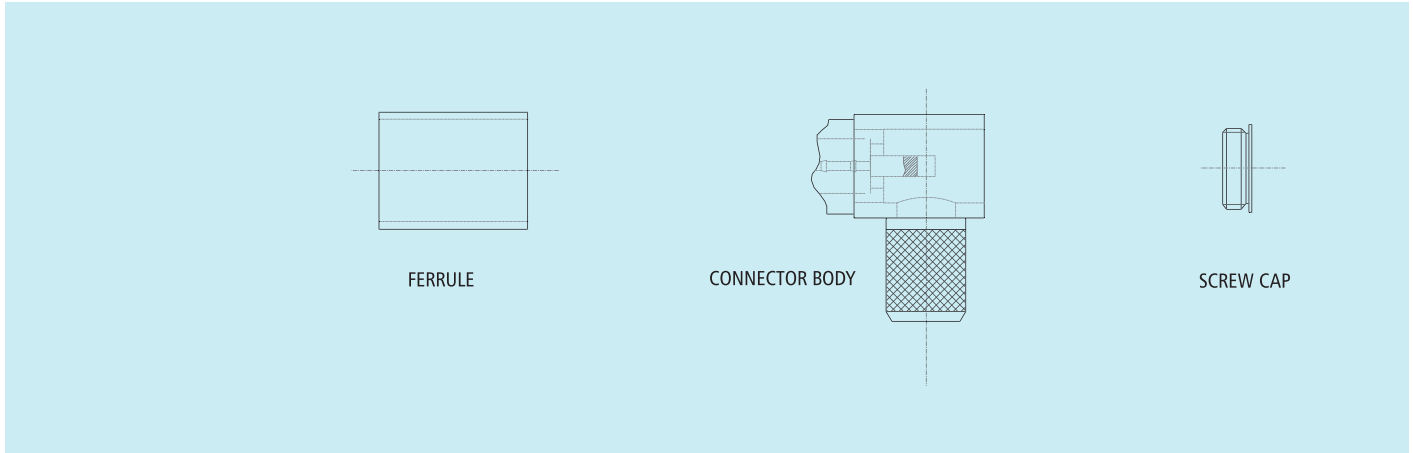

1. Trim cable to the dimensions shown, being careful not to damage the braid, dielectric, foil or inner conductor.

Stripping Detail	C $+0.00 (+.000)$ $-0.50 (-.019)$	D $+0.20 (+.008)$ $-0.00 (-.000)$	E $+0.00 (+.000)$ $-0.20 (-.008)$
A	11.00 (.433)	5.00 (.197)	3.00 (.118)
B	12.50 (.492)	5.00 (.197)	3.00 (.118)

For cables with a foil under the braid, spread braid and trim back to dimensions shown; being careful not to damage the braid, dielectric, foil or inner conductor. Except RA 7000 and 5000 cable, where the foil should be left in place over the dielectric.

2. If fitted, remove the cap from the body of the connector.
3. Place the crimp ferrule over the cable sheath.
4. Fit the connector body onto the cable/conductor so that the rear body slides between the dielectric and braid (gently twisting and rocking the connector body to spread the braids will help) and ensure that the conductor fits into the slot in the rear of the contact.
5. Slide the crimp ferrule forward, over the braid until it butts against the rear of the connector. Crimp using Cannon crimp tool T1025/- fitted with a suitable die set (see table).

Cable Type	Stripping Detail	Die Size	Die Part Number
BT 3002	A	4,3 (.170)	T1025/36
BT 2003	B	6,81 (.268)	T1025/8
BT 5000	B	8,23 (.324)	T1025/17
RA 7000	B	5,18 (.204)	T1025/6
ST212	A	3,80 (.151)	T1025/9
RG179	A	3,25 (.128)	K29263

6. Solder the conductor to the contact and screw in the cap.

RF Coaxial Connectors

Assembly Instructions

BBAI NO.: 1280 Full - crimp/Solder - crimp straight plugs

Tools Required:	Locator: -	Crimp Tool: see table
-----------------	------------	-----------------------

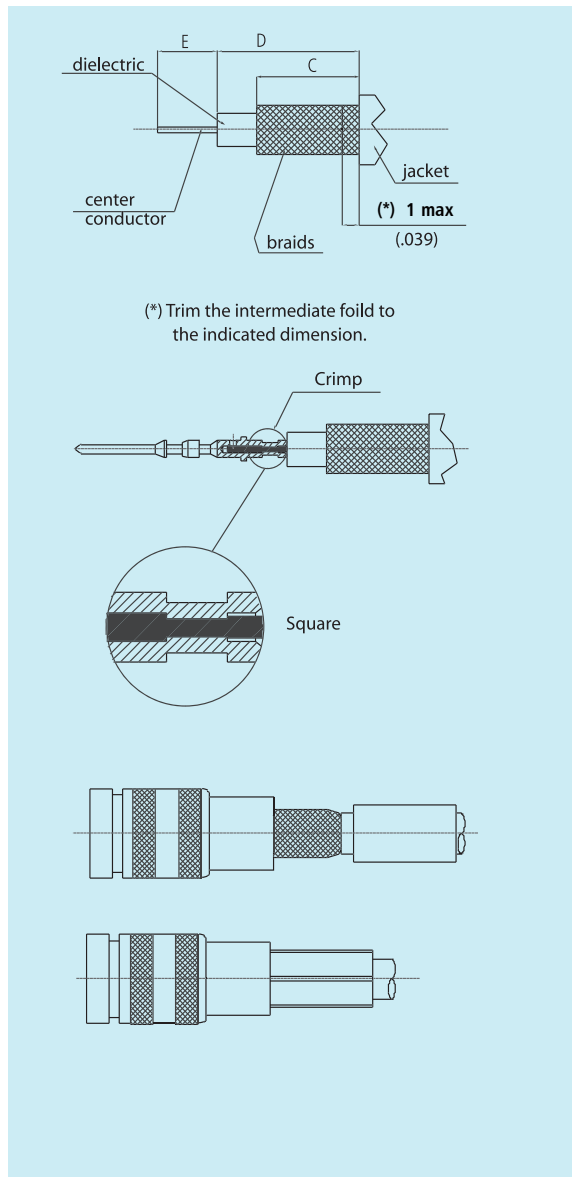
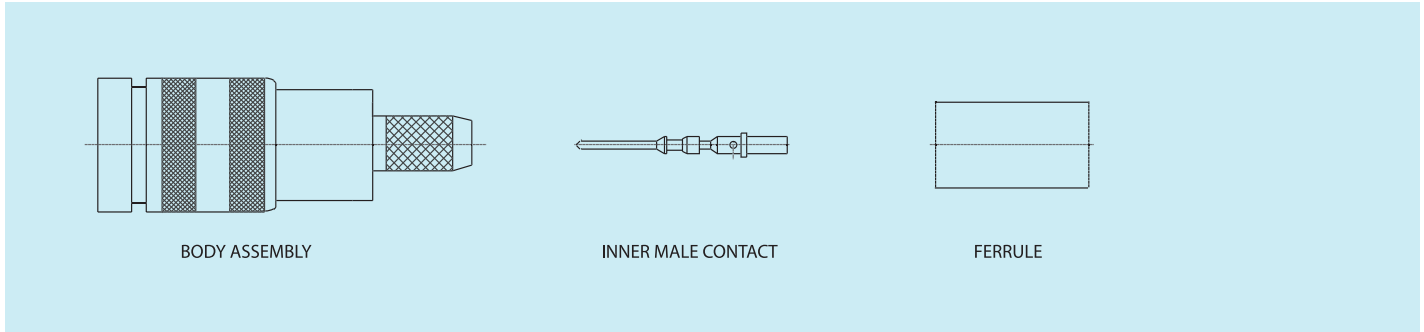

1. Prepare cable to the dimensions shown, being careful not to damage the braid, dielectric, foil or inner conductor.

Stripping Detail	C		D		E	
	+0.00 (+.000)	-0.50 (-.019)	+0.20 (+.008)	-0.00 (-.000)	+0.00 (+.000)	-0.20 (-.008)
A	6.00 (.236)		8.30 (.327)		3.50 (.138)	
B	8.00 (.315)		10.50 (.413)		3.50 (.138)	

For cables with a foil under the braid, spread braid and trim back to dimensions shown.

2. Crimp contact onto inner conductor using a T4870 (Cannon part number , square dimension shown in the table below).

Ensure that the conductor is visible through the inspection hole in the side of the contact.

This contact may also be soldered.

3. Place the crimp ferrule over the cable sheath.

4. Fit the connector body onto the cable/conductor so that the rear body slides between the dielectric and braid (gently twisting and rocking the connector body to spread the braids will help). Push home until a click is felt.

5. Slide the crimp ferrule forward, over the braid until it butts against the rear of the connector. Crimp using Cannon crimp tool T1025/- fitted with a suitable die set (see table).

Cable Type	Stripping Detail	Square Dimension (mm)	Die Size	Die Part Number
ST212	A	0.7 x 0.7	3.8 (.151)	T1025/9
ST214	B	1.0 x 1.0	6.8 (.268)	T1025/8

RF Coaxial Connectors

Assembly Instructions

BBAI NO.: 1281 1.0/2.3 Straight jack full - crimp 50 ohm and 75 ohm

Tools Required:	Locator: T4852	Crimp Tool: see table
-----------------	----------------	-----------------------

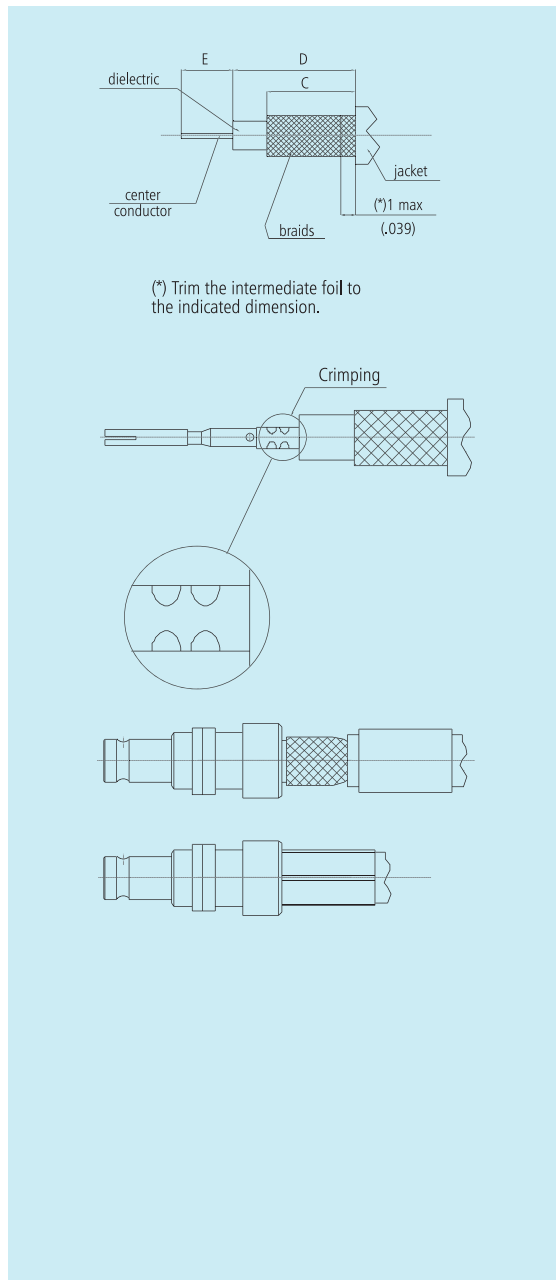
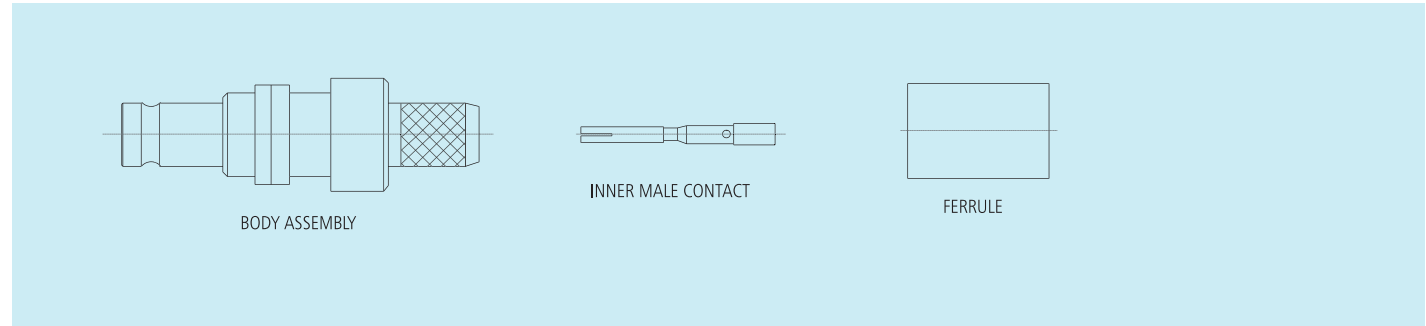

1. Prepare cable to the dimensions shown, being careful not to damage the braid, dielectric, foil or inner conductor.

Stripping Detail	C ^{+0.00 (+.000)} _{-0.50 (-.019)}	D ^{+0.00 (+.000)} _{-0.30 (-.012)}	E ^{+0.00 (+.000)} _{-0.20 (-.008)}
A	6.00 (.236)	9.50 (.374)	3.50 (.138)
B	8.00 (.315)	11.7 (.460)	3.50 (.138)

For cables with a foil under the braid, spread braid and trim back to dimension shown. The foil should be left in place over the dielectric, except RA 7000 cable where the foil should be left in place over the dielectric.

2. Crimp contact onto inner conductor using a M22520/2-01 (Cannon part number 995-0001-584) set to the selector number shown in the table below, fitted with positioner T4852.

Ensure that the conductor is visible through the inspection hole in the side of the contact. This contact may also be soldered.

3. Place the crimp ferrule over the cable sheath.

4. Fit the connector body onto the cable/conductor so that the rear body slides between the dielectric and braid (gently twisting and rocking the connector body to spread the braids will help). Push home until a click is felt.

5. Slide the crimp ferrule forward, over the braid until it butts against the rear of the connector. Crimp using Cannon crimp tool T1025/- fitted with a suitable die set (see table).

Cable Type	Stripping Detail	Selector Setting	Die Size	Die Part Number
RG 58	A	4	5.41 (.213)	K29265
RG 316	A	4	3.25 (.128)	K29263
ST 212	A	3	3.80 (.151)	T1025/9
ST 214	B	4	6.80 (.268)	T1025/8
BT 2003	B	4	6.80 (.268)	T1025/8
BT 3002	A	3	4.30 (.170)	T1025/36
RA 7000	B	4	5.18 (.204)	T1025/6
TZC 75005	B	4	6.50 (.255)	T1025/11
A (04/2.4)	B	3	5.40 (.213)	K29265
B (0.25/1.45)	A	3	3.25 (.128)	K29263
RG179	A	3	3.25 (.128)	K29263
FLEX 2	A	3	3.25 (.128)	K29263

RF Coaxial Connectors

Assembly Instructions

BBAI NO.: 1289 1.0/2.3 Full - crimp/Solder - crimp straight plugs 50 ohm

Tools Required:	Locator: T4852	Crimp Tool: see table
-----------------	----------------	-----------------------

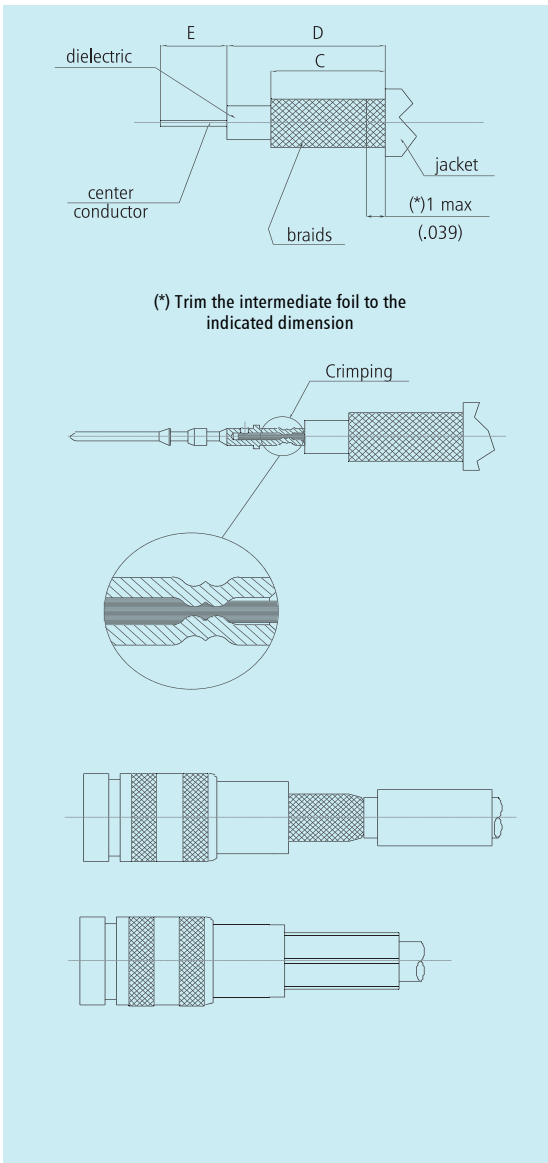
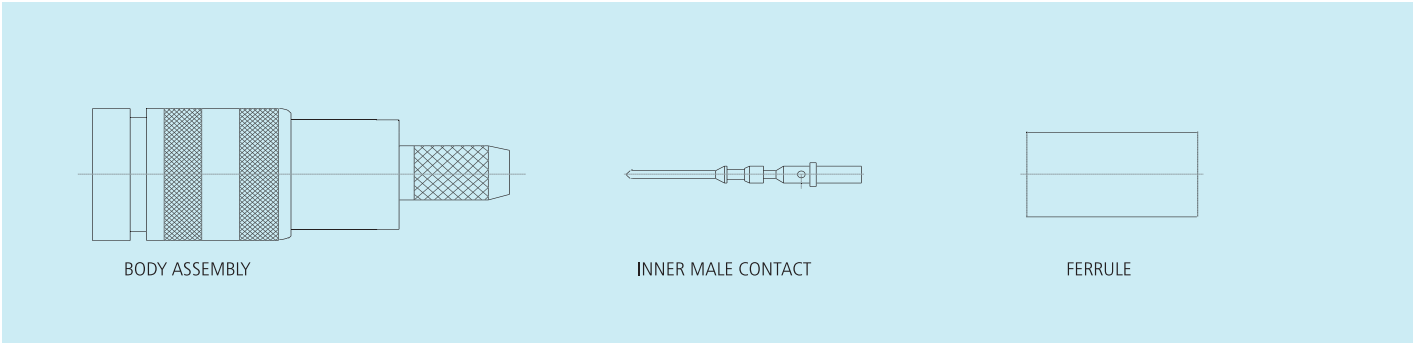

1. Prepare cable to the dimensions shown, being careful not to damage the braid, dielectric, foil or inner conductor.

Stripping Detail	C $\begin{matrix} +0.00 (+.000) \\ -0.50 (-.019) \end{matrix}$	D $\begin{matrix} +0.00 (+.000) \\ -0.30 (-.012) \end{matrix}$	E $\begin{matrix} +0.00 (+.000) \\ -0.20 (-.008) \end{matrix}$
A	6.00 (.236)	8.30 (.327)	3.50 (.138)

For cables with a foil under the braid, spread braid and trim back to dimension shown.

2. Crimp contact onto inner conductor using a M22520/2-01 (Cannon part number 995-0001-584) set to the selector number shown in the table below, fitted with positioner T4852 .

Ensure that the conductor is visible through the inspection hole in the side of the contact. This contact may also be soldered.

3. Place the crimp ferrule over the cable sheath.

4. Fit the connector body onto the cable/conductor so that the rear body slides between the dielectric and braid (gently twisting and rocking the connector body to spread the braids will help). Push home until a click is felt.

5. Slide the crimp ferrule forward, over the braid until it butts against the rear of the connector. Crimp using Cannon crimp tool T1025/- fitted with a suitable die set (see table).

Cable Type	Stripping Detail	Selector Setting	Die Size	Die Part Number
RG 58/U	A	4	5.41 (.213)	K29265
RG 316/U	A	4	3.25 (.128)	K29263

BBAI NO.: 1293 1.0/2.3 Solder crimp Right Angle Jack

Tools Required:	Locator:	Crimp Tool: see instruction 5
-----------------	----------	-------------------------------

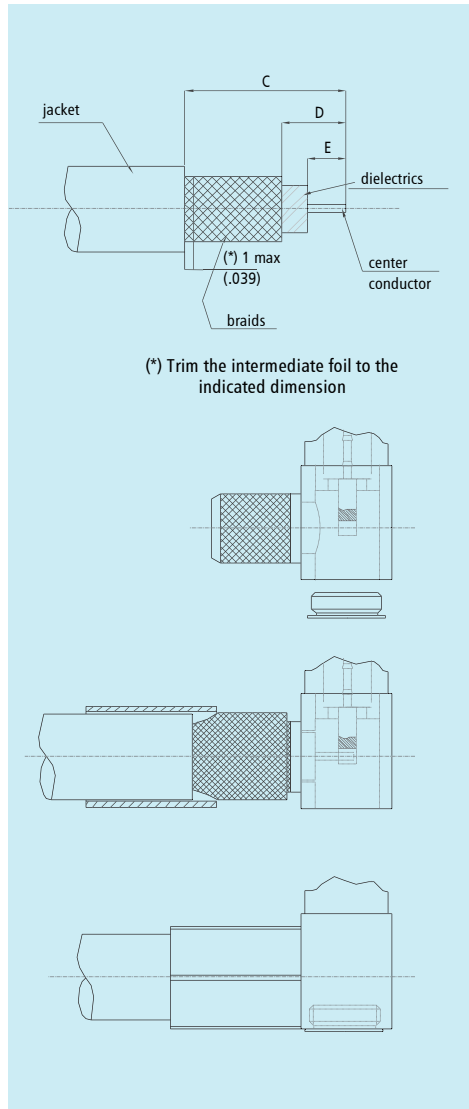
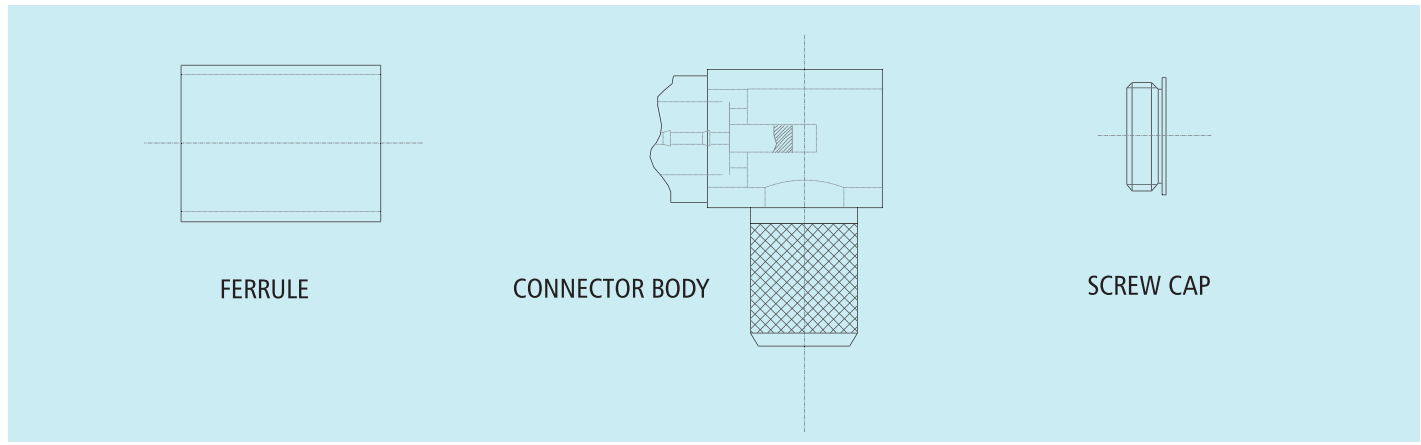

1. Trim cable to the dimensions shown, being careful not to damage the braid, dielectric, foil or inner conductor.

Stripping Detail	C $+0.00 (+.000)$ $-0.50 (-.019)$	D $+0.20 (+.008)$ $-0.00 (-.000)$	E $+0.00 (+.000)$ $-0.20 (-.008)$
A	11.00 (.433)	5.00 (.197)	3.00 (.118)
B	12.50 (.492)	5.00 (.197)	3.00 (.118)

For cables with a foil under the braid, spread braid and trim back to dimensions shown. The foil should be left in place over the dielectric.

2. If fitted, remove the cap from the body of the connector.

3. Place the crimp ferrule over the cable sheath.

4. Fit the connector body onto the cable/conductor so that the rear body slides between the dielectric and braid (gently twisting and rocking the connector body to spread the braids will help) and ensure that the conductor fits into the slot in the rear of the contact.

5. Slide the crimp ferrule forward, over the braid until it butts against the rear of the connector. Crimp using Cannon crimp tool T1025/- fitted with a suitable die set (see table).

Cable Type	Stripping Detail	Die Size	Die Part Number
BT 3002	A	4.30 (.170)	K29265
ST214	A	3.25 (.128)	K29263
ST 212	A	3.80 (.151)	T1025/9
RG 179 B/U	A	3.25 (.128)	K29263

Part Number-Index

Part Number	Page Number	Part Number	Page Number	Part Number	Page Number
051-F53-9019A9H	14	D55-F24-3092GDA	7	D55-F73-0000A9A	18
051-F53-9029A9H	13	D55-F24-3094GDA	7	D55-F73-6000A9A	19
051-F53-9069A9H	13	D55-F24-3095GDA	7	D55-F74-0000A9A	18
055-F24-9019A9G	16	D55-F24-3133GDA	8	D55-F74-6000A9A	19
D51-B27-3058GEA	5	D55-F24-3135GDA	8	D55-F74-6002A9A	20
D51-B27-3060GEA	5	D55-F24-3136GDA	8	D55-F74-6010A9A	19
D51-B51-9001GBA	6	D55-F24-3137GDA	8	D55-F74-6012A9A	20
D51-B51-9002GBA	5	D55-F24-3138GDA	8	D55-F77-0000A9A	18
D51-B51-9003GBA	5	D55-F27-3022GEA	9	D65-F01-0000A9A	21
D51-B53-9004EAA	6	D55-F27-3024GEA	9	D65-F02-0000A9A	21
D51-F30-3022GBA	9	D55-F27-3033GEA	9	D65-F74-0020A9A	21
D51-F30-3024GBA	9	D55-F27-3035GEA	9	D65-F74-6020A9A	21
D51-F30-3035GBA	9	D55-F27-3036GEA	9	T4869	22
D51-F30-3059GBA	9	D55-F27-3037GEA	9	T4839	22
D51-F30-3069GBA	9	D55-F27-3043GEA	9	T4882	22
D51-F30-3090GBA	9	D55-F27-3045GEA	9		
D51-F30-3091GBA	9	D55-F27-3046GEA	9		
D51-F51-9001GBA	10	D55-F27-3051GEA	9		
D51-F51-9002GBA	10	D55-F27-3052GEA	9		
D51-F51-9003GBA	10	D55-F27-3053GEA	9		
D51-F51-9006GBA	10	D55-F27-3054GEA	9		
D51-F53-9004GBA	11	D55-F27-3079GEA	9		
D55-B24-3058GDA	5	D55-F27-3090GEA	9		
D55-B24-3060GDA	5	D55-F27-3091GEA	9		
D55-F24-3001GDA	7	D55-F27-3092GEA	9		
D55-F24-3022GDA	7	D55-F27-3094GEA	9		
D55-F24-3024GDA	7	D55-F27-3095GEA	9		
D55-F24-3033GDA	7	D55-F28-3122A9A	7		
D55-F24-3035GDA	7	D55-F28-3124A9A	7		
D55-F24-3036GDA	7	D55-F28-3133A9A	7		
D55-F24-3037GDA	7	D55-F28-3135A9A	7		
D55-F24-3043GDA	7	D55-F28-3136A9A	7		
D55-F24-3045GDA	7	D55-F28-3137A9A	7		
D55-F24-3046GDA	7	D55-F28-3179A9A	7		
D55-F24-3051GDA	7	D55-F28-3233A9A	8		
D55-F24-3052GDA	7	D55-F28-3235A9A	8		
D55-F24-3053GDA	7	D55-F28-3236A9A	8		
D55-F24-3054GDA	7	D55-F28-3237A9A	8		
D55-F24-3079GDA	7	D55-F28-3238A9A	8		
D55-F24-3090GDA	7	D55-F72-6000A9A	19		
D55-F24-3091GDA	7	D55-F72-6002A9A	20		

OTHER PRODUCTS AVAILABLE FROM ITT INDUSTRIES, CANNON

1. **Circular Connectors**

MS
KPT/KPSE
KPTC
MC/KO
CA-COM
Hermetic
CGK
CGL
PVX
PVXT

2 **'D' Connectors**

D Subminiature
DPXJ/DPX*J
DPD/DPDMA
D*M/D*MA
D*
D*A
D*JK
D*PF
D*T
D*U
D*W
Solda D

3 **RPX Rectangular Connectors**

4 **Sockets for Chip Carriers**

5 **LAN Connect Data Components**

6 **Tempus Connectors**

7 **DIN 41612 Connectors**

8 **Smart Card Connectors**

9 **Rack & Panel Connectors**



Product Safety Information

THIS NOTE MUST BE READ IN CONJUNCTION WITH THE PRODUCT DATA SHEET/CATALOG.

FAILURE TO OBSERVE THE ADVICE IN THIS INFORMATION SHEET AND THE OPERATING CONDITIONS SPECIFIED IN THE PRODUCT DATA SHEET/CATALOG COULD RESULT IN HAZARDOUS SITUATIONS.

1 MATERIAL CONTENT AND PHYSICAL FORM

Electrical connectors do not usually contain hazardous materials. They contain conducting and non-conducting materials and can be divided into two groups.

a) Printed circuit types and low cost audio types which employ all plastic insulators and casings.

b) Rugged, Fire Barrier and High Reliability types with metal casings and either natural rubber, synthetic rubber, plastic or glass insulating materials. Contact materials vary with type of connector and also application and are usually manufactured from either: Copper, copper alloys, nickel, alumel, chromel or steel. In special applications, other alloys may be specified.

2 FIRE CHARACTERISTICS AND ELECTRIC SHOCK HAZARD

There is no fire hazard when the connector is correctly wired and used within the specified parameters. Incorrect wiring or assembly of the connector or careless use of metal tools or conductive fluids, or transit damage to any of the component parts may cause electric shock or burns. Live circuits must not be broken by separating mated connectors as this may cause arcing, ionisation and burning.

Heat dissipation is greater at maximum resistance in a circuit. Hot spots may occur when resistance is raised locally by damage, e.g. cracked or deformed contacts, broken strands of wire. Local overheating may also result from the use of the incorrect application tools or from poor quality soldering or slack screw terminals. Overheating may occur if the ratings in the product Data Sheet/Catalog are exceeded and can cause breakdown of insulation and hence electric shock.

If heating is allowed to continue it intensifies by further increasing the local resistance through loss of temper of spring contacts, formation of oxide film on contacts and wires and leakage currents through carbonisation of insulation and tracking paths.

Fire can then result in the presence of combustible materials and this may release noxious fumes. Overheating may not be visually apparent. Burns may result from touching overheated components.

3 HANDLING

Care must be taken to avoid damage to any component parts of electrical connectors during installation and use. Although there are normally no sharp edges, care must be taken when handling certain components to avoid injury to fingers.

Electrical connectors may be damaged in transit to the customers, and damage may result in creation of hazards. Products should therefore be examined prior to installation/use and rejected if found to be damaged.

4 DISPOSAL

Incineration of certain materials may release noxious or even toxic fumes.

5 APPLICATION

Connectors with exposed contacts should not be selected for use on the current supply side of an electrical circuit, because an electric shock could result from touching exposed contacts on an unmated connector. Voltages in excess of 30 V ac. or 42.5 V dc are potentially hazardous and care should be taken to ensure that such voltages cannot be transmitted in any way to exposed metal parts of the connector body. The connector and wiring should be checked, before making live, to have no damage to metal parts or insulators, no solder blobs, loose strands, conducting lubricants, swarf, or any other undesired conducting particles. Insulation resistance should be checked to make certain that no low resistance joints or spurious conducting paths are existing between contacts and exposed metal parts of the connector body. Further, the contact resistance of the connectors should be measured within the electrical circuit in order to identify high resistances, which result in excessive connector heating.

Always use the correct application tools as specified in the Data Sheet/Catalogue.

Do not permit untrained personnel to wire, assemble or tamper with connectors.

For operation voltage please see appropriate national regulations.

IMPORTANT GENERAL INFORMATION

(i) Air and creepage paths/Operating voltage

The admissible operating voltages depend on the individual applications and the valid national and other applicable safety regulations.

For this reason the air and creepage path data are only reference values. Observe reduction of air and creepage paths due to PC board and/or harnessing.

(ii) Temperature

All information given are temperature limits. The operation temperature depends on the individual application.

(iii) Other important information

ITT Industries continuously endeavours to improve their products. Therefore, ITT Industries products may deviate from the description, technical data and shape as shown in this catalog and data sheets.

(iv) Harnessing and Assembly Instructions

If applicable, our special harnessing and/or assembly instruction has to be adhered to. This is provided on request.

Cannon Worldwide Facilities

Austria:

Afrikanergasse 3
1020 Vienna
FAX: 43.1.2160948 PH: 43.1.2160947

Belgium:

Residence Leopold
Genevestreet 10
1140 Brussels
FAX: 32.2.7269201 PH: 32.2.7267594

China:

No. 24, Block 2
Taohuawu New District
Zhenjiang, Jiangsu 212003
FAX: 86.511.442.8616 PH: 86.511.443.3399

Denmark:

Park Allé 287 A
2605 Brøndby
FAX: 45.43.43.58.58 PH: 45.43.45.52.88

France:

2, Ave des Sablons Bouillants,
77109 Meaux Cedex
FAX: 33.1.64.33.16.82 PH: 33.1.60.24.51.51

Germany:

Postfach 11 20
71365 Weinstadt (letters)
Cannonstrasse 1
71384 Weinstadt (parcels)
FAX: 49.7151.699.217 PH: 49.7151.699.0

Hong Kong:

Unit 901 & 912, West Tower, Shun Tak Center
168-200 Connaught Road Central, Hong Kong
FAX: 852.2732.2919 PH: 852.2732.2720

Italy:

Via Panzeri 10
20123 Milano
FAX: 39.2.8372036 PH: 39.2.58180.1

Japan:

5362-1, 5-chome, Hibarigaoka,
Zama-shi, Kanagawa 228-0003
FAX: 81.462.57.1680 PH: 81.462.57.2010

Korea:

620 Changkang Bldg.
#22, Dohwa-dong, Mapo-ku
Seoul
FAX: 82.2.717.7330 PH: 82.2.702.7111

The Netherlands

FAX: 31.35.691.8796 PH: 31.35.691.6855

Spain:

Edificio Italia 1a Planta
Parque Empresarial San Fernando
San Fernando de Henares, Spain 28831
FAX: 34.91.656.15.83 PH: 34.91.656.03.11

Switzerland:

Herzogenmühle 18
8304 Wallisellen PH: 41.1.830.3888
FAX: 41.1.830.3104 PH: 41.1.830.3613

United Kingdom:

Jays Close, Viables Estate
Basingstoke, Hants, RG22 4BA
FAX: 44.1256.323356 PH: 44.1256.311200

United States:

100 Sebeth Drive
Cromwell, CT 06416
FAX: 1.860.635.2010 PH: 1.860.635.1500

Internet:

www.ittcannon.com

Cannon



ITT Industries

Engineered for life