

MICREL[®]

**÷2/4, ÷4/5/6 CLOCK
GENERATION CHIP**

**Precision Edge[®]
SY100S839V**

FEATURES

- 3.3V and 5V power supply option
- 50ps output-to-output skew
- 50% duty cycle outputs
- Synchronous enable/disable
- Master Reset for synchronization
- Internal 75KΩ input pull-down resistors
- Available in 20-pin SOIC package



Precision Edge[®]

DESCRIPTION

The SY100S839V is a low skew ÷2/4, ÷4/5/6 clock generation chip designed explicitly for low skew clock generation applications. The internal dividers are synchronous to each other, therefore, the common output edges are all precisely aligned. The device can be driven by either a differential or single-ended ECL/LVECL or, if positive power supplies are used, PECL/LVPECL input signal. In addition, by using the VBB output, a sinusoidal source can be AC-coupled into the device. If a single-ended input is to be used, the VBB output should be connected to the /CLK input and bypassed to ground via a 0.01μF capacitor. The VBB output is designed to act as the switching reference for the input of the S839V under single-ended input conditions. As a result, this pin can only source/sink up to 0.5mA of current.

The common enable (/EN) is synchronous so that the internal dividers will only be enabled/disabled when the internal clock is already in the LOW state. This avoids any chance of generating a runt clock pulse on the internal clock when the device is enabled/disabled as can happen with an asynchronous control. An internal runt pulse could lead to losing synchronization between the internal divider stages. The internal enable flip-flop is clocked on the falling edge of the input clock, therefore, all associated specification limits are referenced to the negative edge of the clock input.

Upon start-up, the internal flip-flops will attain a random state; the master reset (MR) input must be asserted to ensure synchronization. For systems which only use one S839V, the MR pin need not be exercised as the internal divider designs ensures synchronization between the ÷2/4, and the ÷4/5/6 outputs of a single device.



PACKAGE/ORDERING INFORMATION

Ordering Information

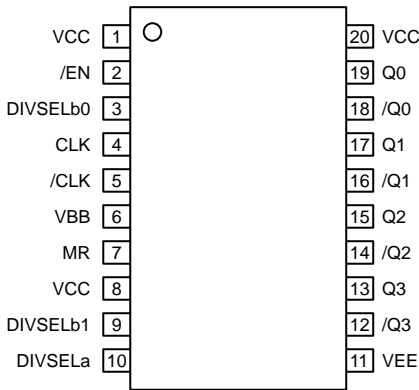

20-Pin SOIC (Z20-1)

Part Number	Package Type	Operating Range	Package Marking	Lead Finish
SY100S839VZC	Z20-1	Commercial	SY100S839VZC	Sn-Pb
SY100S839VZCTR ⁽¹⁾	Z20-1	Commercial	SY100S839VZC	Sn-Pb
SY100S839VZG ⁽²⁾	Z20-1	Industrial	SY100S839VZG with Pb-Free bar-line indicator	Pb-Free NiPdAu
SY100S839VZGTR ^(1, 2)	Z20-1	Industrial	SY100S839VZG with Pb-Free bar-line indicator	Pb-Free NiPdAu

Notes:

1. Tape and Reel.
2. Pb-Free package is recommended for new designs.

TRUTH TABLE

CLK	/EN	MR	Function
Z	L	L	Divide
ZZ	H	L	Hold Q ₀₋₃
X	X	H	Reset Q ₀₋₃

Note:

Z = LOW-to-HIGH transition
ZZ = HIGH-to-LOW transition

DIVSELa	Q ₀ , Q ₁ OUTPUTS
0	Divide by 2
1	Divide by 4

DIVSELb1	DIVSELb0	Q ₂ , Q ₃ OUTPUTS
0	0	Divide by 4
0	1	Divide by 6
1	0	Divide by 5
1	1	Divide by 5

PIN NAMES

Pin	Function
CLK	Differential Clock Inputs
/EN	Synchronous Enable
MR	Master Reset
VBB	Reference Output
Q ₀ , Q ₁	Differential ±2/4 Outputs
Q ₂ , Q ₃	Differential ±4/5/6 Outputs
DIVSEL	Frequency Select Input

DC ELECTRICAL CHARACTERISTICS⁽¹⁾

VEE = VEE (min) to VEE (max); VCC = GND

Symbol	Parameter	TA = -40°C			TA = 0°C			TA = +25°C			TA = +85°C			Unit
		Min.	Typ.	Max.	Min.	Typ.	Max.	Min.	Typ.	Max.	Min.	Typ.	Max.	
IEE	Power Supply Current	—	50	95	—	50	95	—	50	95	—	54	95	mA
VBB	Output Reference Voltage	-1.38	—	-1.26	-1.38	—	-1.26	-1.38	—	-1.26	-1.38	—	-1.26	V
I _{IH}	Input High Current	—	—	150	—	—	150	—	—	150	—	—	150	μA
V _{OH}	Output HIGH Voltage ⁽²⁾	-1085	-1005	-880	-1025	-955	-880	-1025	-955	-880	-1025	-955	-880	mV
V _{OL}	Output LOW Voltage ⁽²⁾	-1830	-1695	-1555	-1810	-1705	-1620	-1810	-1705	-1620	-1810	-1705	-1620	mV
V _{OHA}	Output HIGH Voltage ⁽³⁾	-1095	—	—	-1035	—	—	-1035	—	—	-1035	—	—	mV
V _{OLA}	Output LOW Voltage ⁽³⁾	—	—	-1555	—	—	-1610	—	—	-1610	—	—	-1610	mV
V _{IH}	Input HIGH Voltage	-1165	—	-880	-1165	—	-880	-1165	—	-880	-1165	—	-880	mV
V _{IL}	Input LOW Voltage	-1810	—	-1475	-1810	—	-1475	-1810	—	-1475	-1810	—	-1475	mV
I _{IL}	Input LOW Current ⁽⁴⁾	0.5	—	—	0.5	—	—	0.5	—	—	0.5	—	—	μA

Note:

1. Parametric values specified at: -3.0V to -3.8V or -4.2V to -5.5V.
2. V_{IN} = V_{IH}(Max) or V_{IL}(Min): Loading with 50Ω to -2.0V.
3. V_{IN} = V_{IH}(Min) or V_{IL}(Max): Loading with 50Ω to -2.0V.
4. V_{IN} = V_{IL}(Min).

AC ELECTRICAL CHARACTERISTICS⁽¹⁾

VEE = VEE (min) to VEE (max); VCC = GND

Symbol	Parameter	TA = -40°C			TA = 0°C			TA = +25°C			TA = +85°C			Unit	
		Min.	Typ.	Max.	Min.	Typ.	Max.	Min.	Typ.	Max.	Min.	Typ.	Max.		
fMAX	Maximum Toggle Frequency	1000	—	—	1000	—	—	1000	—	—	1000	—	—	MHz	
tPD	Propagation Delay to Output													ps	
	CLK → Output (Diff.)	725	—	925	725	—	925	725	—	925	725	—	925		
	CLK → Output (S.E.)	675	—	975	675	—	975	675	—	975	675	—	975		
	MR → Output	600	—	900	600	—	900	610	—	910	630	—	930		
tskew	Within-Device Skew ⁽²⁾ Q0 — Q3	—	—	50	—	—	50	—	—	50	—	—	50	ps	
	Part-to-Part Q0 — Q3 (Diff.)	—	—	200	—	—	200	—	—	200	—	—	200		
ts	Set-up Time /EN → /CLK	250	—	—	250	—	—	250	—	—	250	—	—	ps	
	DIVSEL → CLK	400	—	—	400	—	—	400	—	—	400	—	—		
tH	Hold Time /CLK → /EN	100	—	—	100	—	—	100	—	—	100	—	—	ps	
	CLK → DIVSEL	150	—	—	150	—	—	150	—	—	150	—	—		
VPP	Minimum Input Swing ⁽³⁾ CLK	250	—	—	250	—	—	250	—	—	250	—	—	mV	
VCMR	Common Mode Range ^{(4), (5)}	-1.6	—	-0.4	-1.7	—	-0.4	-1.7	—	-0.4	-1.7	—	-0.4	V	
tRR	Reset Recovery Time	—	—	100	—	—	100	—	—	100	—	—	100	ps	
tPW	Minimum Pulse Width CLK	500	—	—	500	—	—	500	—	—	500	—	—	ps	
	MR	700	—	—	700	—	—	700	—	—	700	—	—		
tr	Output Rise/Fall Times (20% —80%)	Q	280	—	550	280	—	550	280	—	550	280	—	550	ps
tf															

Notes:

1. Parametric values specified at: -3.0V to -3.8V or -4.2V to -5.5V.
2. Skew is measured between outputs under identical transitions.
3. Minimum input swing for which AC parameters are guaranteed. The device will function reliably with differential inputs down to 100mV.
4. The CMR range is referenced to the most positive side of the differential input signal. Normal operation is obtained if the HIGH level falls within the specified range and the peak-to-peak voltage lies between VPP min. and 1V. The lower end of the CMR range varies 1:1 with VEE. The numbers in the spec table assume a nominal VEE = -3.3V. Note for PECL operation, the VCMR (min) will be fixed at 3.3V - IVCMR (min)I.
5. Duty Cycle: (Min. 48%; Max. 52%) } over temp.

LOGIC DIAGRAM

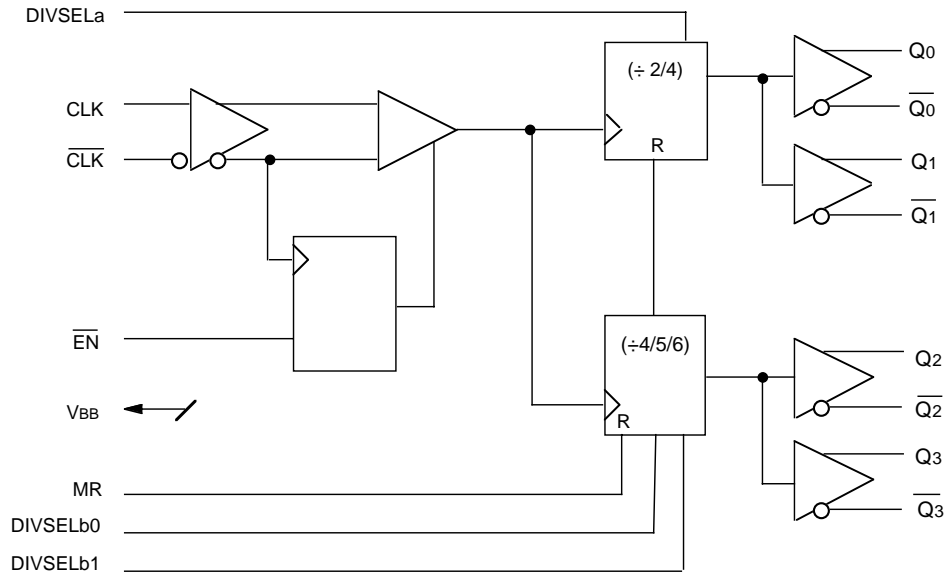

TIMING DIAGRAMS

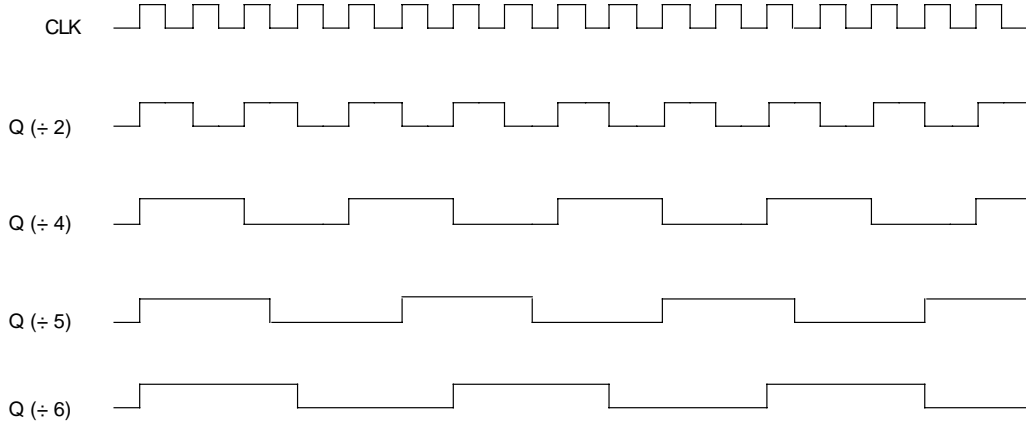

20-PIN SOIC .300" WIDE (Z20-1)

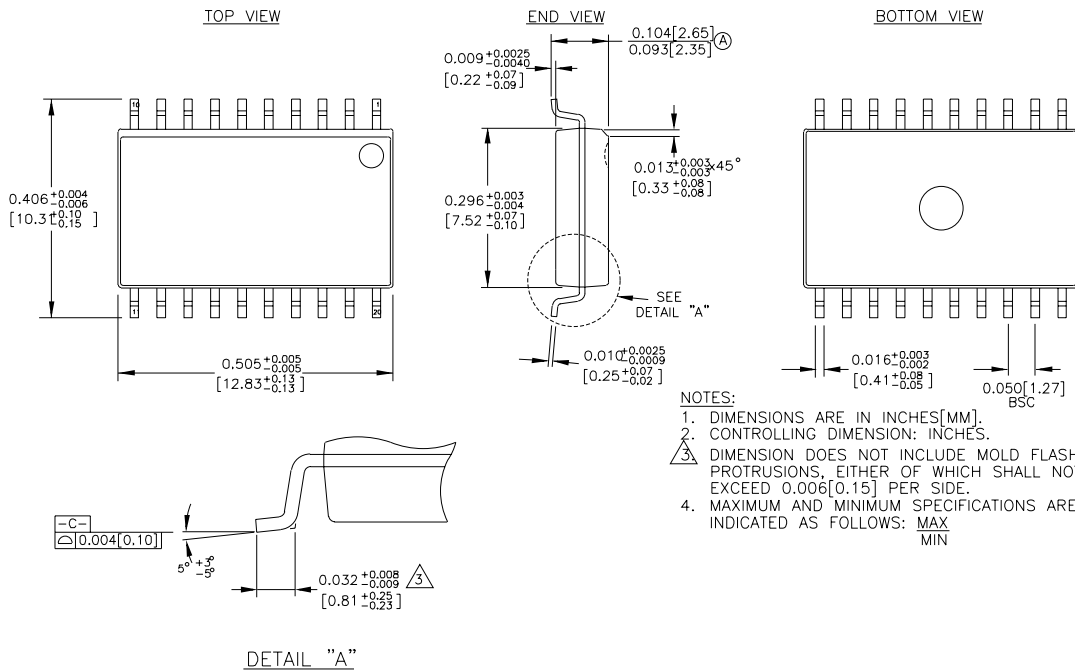

Rev. 03

MICREL, INC. 2180 FORTUNE DRIVE SAN JOSE, CA 95131 USA

TEL + 1 (408) 944-0800 FAX + 1 (408) 474-1000 WEB <http://www.micrel.com>

The information furnished by Micrel in this datasheet is believed to be accurate and reliable. However, no responsibility is assumed by Micrel for its use. Micrel reserves the right to change circuitry and specifications at any time without notification to the customer.

Micrel Products are not designed or authorized for use as components in life support appliances, devices or systems where malfunction of a product can reasonably be expected to result in personal injury. Life support devices or systems are devices or systems that (a) are intended for surgical implant into the body or (b) support or sustain life, and whose failure to perform can be reasonably expected to result in a significant injury to the user. A Purchaser's use or sale of Micrel Products for use in life support appliances, devices or systems is at Purchaser's own risk and Purchaser agrees to fully indemnify Micrel for any damages resulting from such use or sale.