

16-Channel Serial to Parallel Converter with High Voltage Backplane Driver and Push-Pull Outputs

Features

- ▶ HVCMOS® technology
- ▶ Output voltage up to +200V
- ▶ Shift register speed 500kHz @ $V_{DD} = 2.0V$
- ▶ 16 high voltage outputs
- ▶ High voltage backplane driver
- ▶ CMOS input levels

Applications

- ▶ Multiple segment EL display
- ▶ Piezoelectric transducer driver
- ▶ Braille driver

General Description

The HV509 is a 200V, 16-channel serial to parallel converter. The high voltage outputs and the backplane driver are designed to source and sink $\pm 1.0mA$.

The high voltage outputs are controlled by a 16-bit serial shift register, followed by a 16-bit latch. Data is shifted through the shift registers during the low to high clock transition. A data output buffer is provided for cascading multiple devices. Data is transferred to the 16-bit latch when a logic level low is applied to the \overline{LE} input. Data is stored in the latch when \overline{LE} is high. Output states are controlled by the data in the latch and by the \overline{POL} pin.

Typical Application Circuit

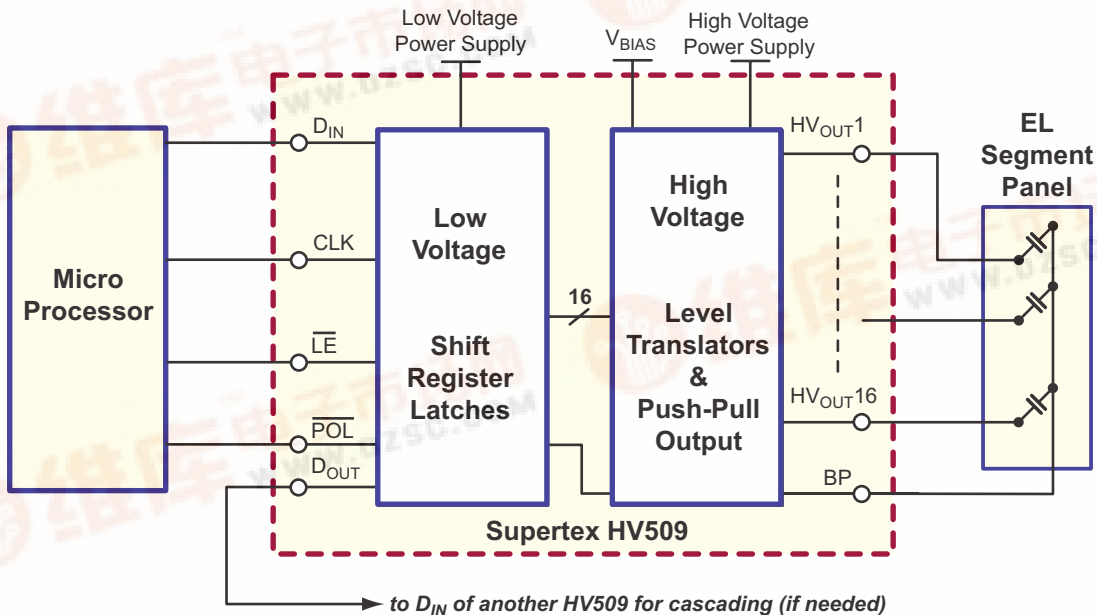

Ordering Information

Device	Package Options
	32-Lead QFN 5x5mm body, 1.0mm height (max), 0.50 pitch
HV509	HV509K6-G

-G indicates package is RoHS compliant ("Green")



Pin Configuration

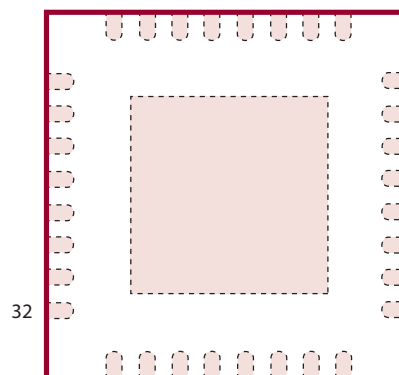

1 **32-Lead QFN**
(top view)

Pads are at the bottom of the package.
Exposed heat slug is at V_{PP} potential.

Absolute Maximum Ratings

Parameter	Value
Logic supply, V _{DD}	-0.5V to 7.0V
High voltage supply, V _{PP}	215V
Translator supply voltage, V _{BIAS}	-0.5V to 7.0V
Logic input levels	-0.5V to V _{DD} + 0.5V
Operating junction temperature	-40°C to +125°C
Storage temperature range	-65°C to +150°C

Absolute Maximum Ratings are those values beyond which damage to the device may occur. Functional operation under these conditions is not implied. Continuous operation of the device at the absolute rating level may affect device reliability. All voltages are referenced to device ground.

Product Marking

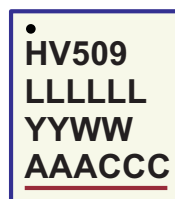

L = Lot Number
YY = Year Sealed
WW = Week Sealed
A = Assembler ID
C = Country of Origin
— = "Green" Packaging

32-Lead QFN

Operating Supply Voltages and Conditions

Symbol	Parameter	Min	Typ	Max	Units	Conditions
V _{DD}	Logic supply voltage	2.0	3.0	5.5	V	---
V _{BIAS}	Level translator supply voltage	2.6	-	6.6	V	---
V _{PP}	Positive high voltage supply	50	-	200	V	---
V _{IH}	High-level input voltage	0.9V _{DD}	-	V _{DD}	V	---
V _{IL}	Low-level input voltage	0	-	0.1V _{DD}	V	---
T _A	Operating temperature	0	-	+70	°C	---

Notes:

- (1) External ground noise reduction circuit will be provided by design upon characterization.
- (2) Power-up sequence should be the following*:
 1. Apply ground
 2. Apply V_{DD}
 3. Set all inputs (D_{IN}, CLK, \overline{LE} , \overline{POL}) to a known state
 4. Apply V_{BIAS}
 5. Apply V_{PP}
- (3) Power-down sequence should be the reverse of the above

*This power up sequence requires an external high voltage diode between VDD and VPP. Without the diode, power up VPP to a VDD level first to bias the silicon substrate. After all other signals are powered, finish raising the V_{PP} to its final level.

DC Electrical Characteristics (Over operating supply voltages and temperature, unless otherwise noted)

Symbol	Parameter	Min	Typ	Max	Units	Conditions	
I_{DD}	V_{DD} supply current	-	-	1.0	mA	$f_{CLK} = 500kHz$	
I_{DDQ}	Quiescent V_{DD} supply current	-	-	10	μA	All logic inputs = V_{DD} or 0V	
I_{BIAS}	V_{BIAS} supply current	-	-	100	μA	All HV _{OUTS} switching at 1kHz. Peak $I_{BIAS} = 200mA$ with all channels switching	
I_{BIASQ}	Quiescent V_{BIAS} current	-	-	10	μA	No HV _{OUT} switching	
I_{PPQ}	Quiescent V_{PP} supply current	-	-	100	μA	$V_{PP} = 200V$, outputs are static	
I_{IH}	High-level logic input current	-	-	10	μA	$V_{IH} = V_{DD}$	
I_{IL}	Low-level logic input current	-	-	-10	μA	$V_{IL} = 0V$	
V_{OH}	High level output	HV _{OUT} & BP	$V_{PP} - 12V$	-	-	V	IHV _{OUT} = -1.0mA, $V_{PP} = +200V$
			$V_{PP} - 12V$	--	-	V	IHV _{OUT} = -1.0mA, $V_{PP} = +50V$
		D _{OUT}	$V_{DD} - 1.0V$	-	-	V	ID _{OUT} = -1.0mA
V_{OL}	Low level output	HV _{OUT} & BP	-	-	12	V	IHV _{OUT} = 1.0mA, $V_{BIAS} = 5.4V$, $V_{PP} = +50$ to $+200V$
		D _{OUT}	-	-	1.0	V	ID _{OUT} = 1.0mA
C_{DIN}	Logic input capacitance	-	-	10	pF	---	
C_{DOUT}	Logic output capacitance	-	-	10	pF	---	

AC Electrical Characteristics (Over operating supply voltages and temperature, unless otherwise noted)

Symbol	Parameter	Min	Typ	Max	Units	Conditions
f_{CLK}	Clock frequency	0	-	500	kHz	---
t_C	Clock high / low pulse width	1	-	-	μs	---
t_{SU}	Data setup time before clock rises	50	-	-	ns	---
t_H	Data hold time after clock rises	-	-	50	ns	---
t_{CLE}	\overline{LE} from CLK setup time	15	-	-	ns	---
t_{WLE}	\overline{LE} pulse width	100	-	-	ns	---
t_{DD}	Clock negative edge to D _{OUT} delay	-	-	150	ns	$C_{LDOUT} = 50pF$, (C_{LDOUT} includes C_{DIN} and C_{DOUT})
t_{PHV}	Delay time from inputs for HV _{OUT} / BP to start rise/fall	-	-	500	ns	$V_{PP} = 200V$, $V_{BIAS} = 5.4V$
t_{OR}	HV _{OUTPUT} / BP rise time	-	-	300	μs	$C_L = 1500pF$, $V_{PP} = 200V$
t_{OF}	HV _{OUTPUT} / BP fall time	-	-	300	μs	$C_L = 1500pF$, $V_{BIAS} = 5.4V$, $V_{PP} = 200V$
t_{OC}	Width of \overline{POL} pulses	$t_{PHV} + t_{OR}/t_{OF}$	-	-	μs	---

Input and Output Equivalent Circuits

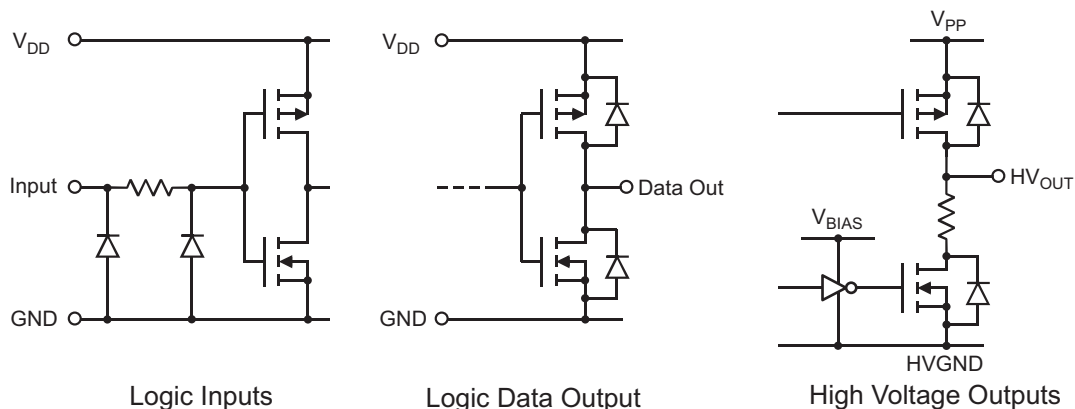

V_{BIAS} SUPPLY

The V_{BIAS} supply operates from 2.6V to 6.6V. It is the gate drive voltage for all of the output N-channel MOSFETs. This allows the output peak current sink to be set by varying the V_{BIAS} voltage. A higher V_{BIAS} voltage will increase the current sinking capability.

If large peak currents are not required, V_{DD} and V_{BIAS} can be connected to the same power supply, provided they are both within the operating range. The operating V_{DD} range is 2.0V to 5.5V. A plot showing the typical characteristics of I_{SINK} vs V_{BIAS} is shown below.

Typical HV_{OUT} I_{SINK} vs V_{BIAS}

(V_{PP} = 200V, C_{LOAD} = 1nF)

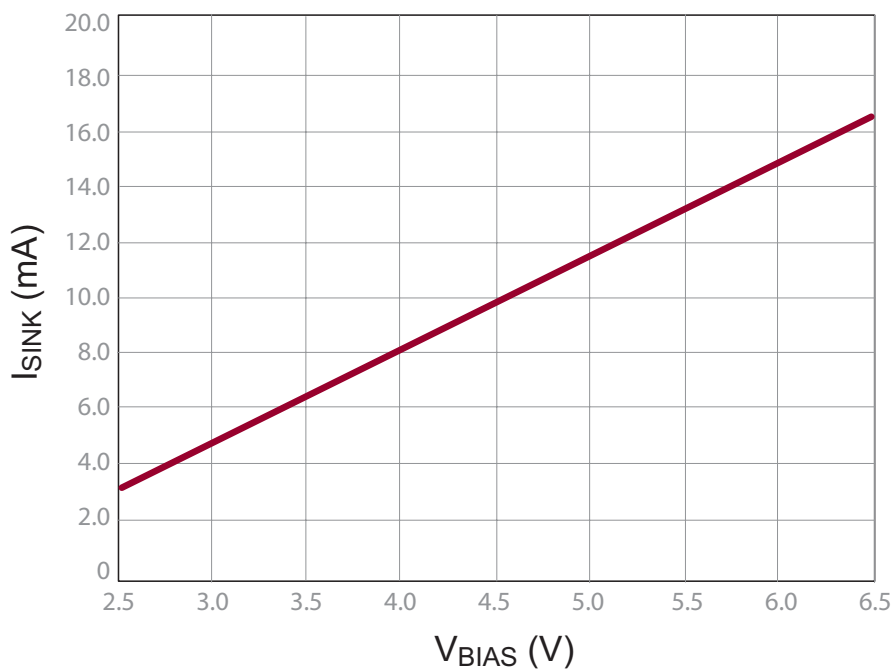

Switching Waveforms

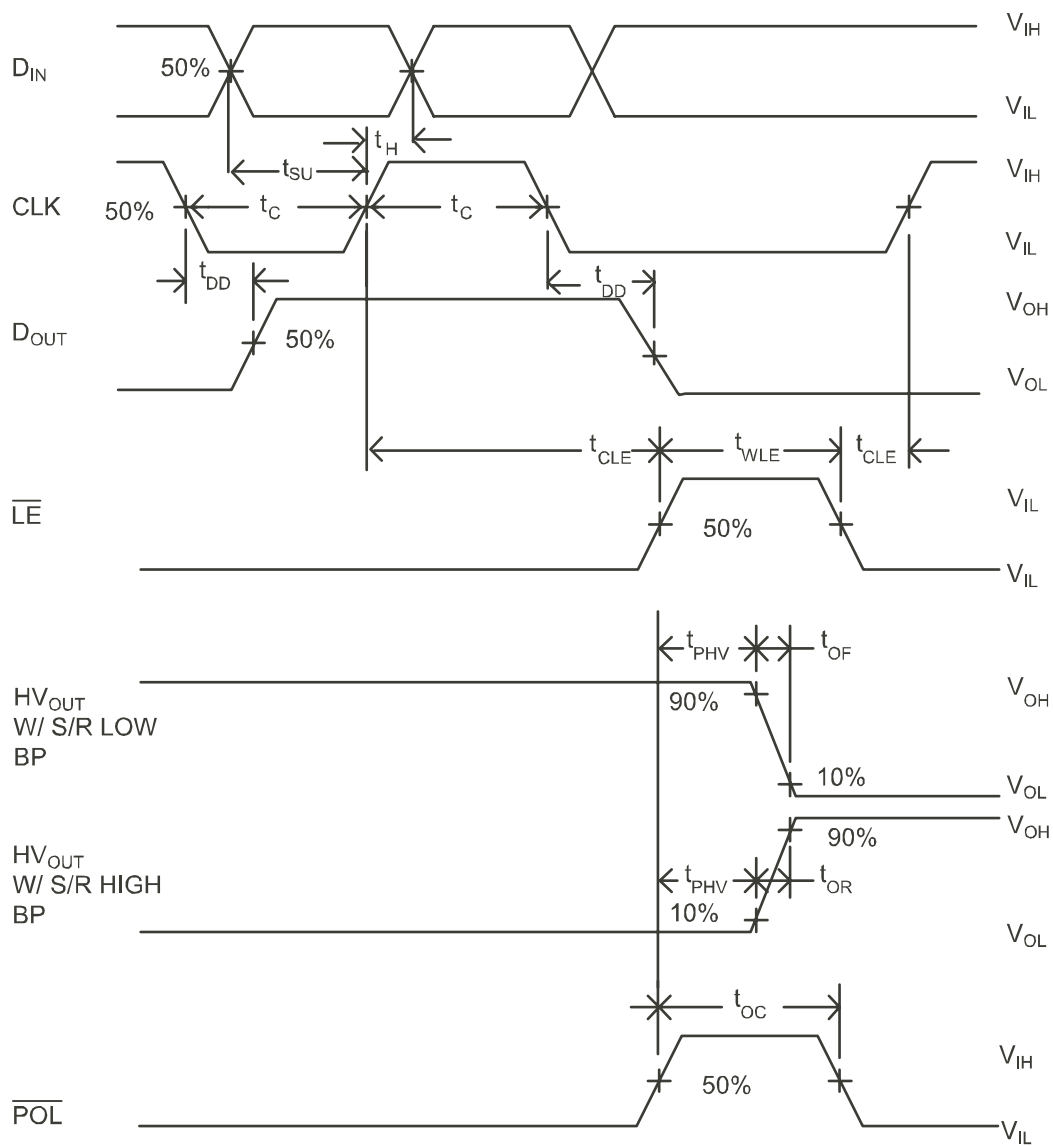

Functional Block Diagram

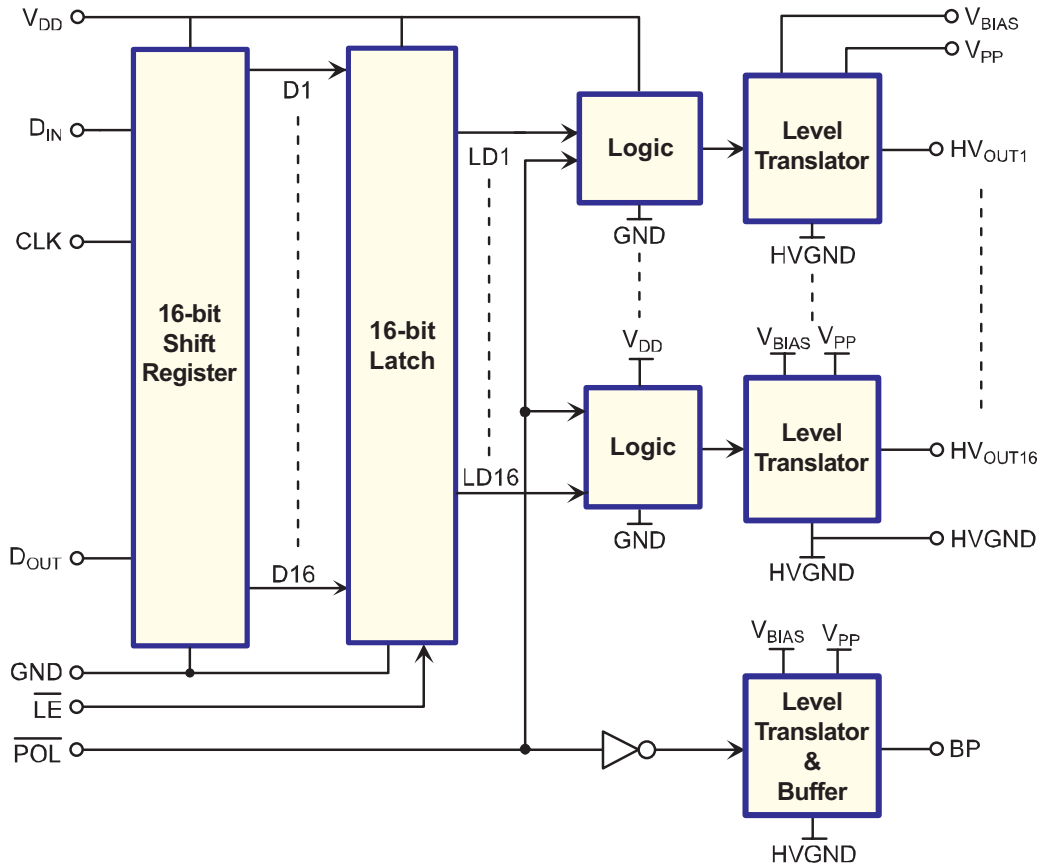

Function Table

Function	Inputs				Outputs			
	D _{IN}	CLK	\overline{LE}	\overline{POL}	Shift Reg 1 2...16	HV Outputs 1 2...16	BP	D _{OUT}
Load S/R	H OR L	↑	H	X	H or L ●...●	● ●...●	X	●
Transfer data in latch	X	L	L	H	* *.....*	* *.....*	L	●
	X	L	L	L	* *.....*	* *.....*(b)	H	●
Store data in latches	X	X	H	H	● ●...●	● ●...●	L	●
	X	X	H	L	● ●...●	● ●...●(b)	H	●
Transparent mode	L	↑	L	H	L ●...●	L ●...●	L	●
	H	↑	L	H	H ●...●	H ●...●	L	●
Invert mode	X	X	H	L	● ●...●	● ●...●(b)	H	X
	X	X	H	H	● ●...●	● ●...●	L	X

Notes:

- H = high level, L = low level, X = irrelevant, ↑ = low-to-high transition
- = dependent on previous stage's state before the last CLK or last \overline{LE} low
- * = data at the last CLK ↑
- (b) = bar over all symbols

Pin Description

Pin #	Function	Description
1	HV _{OUT} 12	High voltage push-pull output
2	HV _{OUT} 11	High voltage push-pull output
3	HV _{OUT} 10	High voltage push-pull output
4	HV _{OUT} 9	High voltage push-pull output
5	HV _{OUT} 8	High voltage push-pull output
6	HV _{OUT} 7	High voltage push-pull output
7	HV _{OUT} 6	High voltage push-pull output
8	HV _{OUT} 5	High voltage push-pull output
9	HV _{OUT} 4	High voltage push-pull output
10	HV _{OUT} 3	High voltage push-pull output
11	HV _{OUT} 2	High voltage push-pull output
12	HV _{OUT} 1	High voltage push-pull output
13	NC	No connect
14	VPP	High voltage supply
15	GND	Logic ground
16	NC	No connect
17	DIN	Data in
18	NC	No connect
19	CLK	Clock input logic
20	VDD	Logic supply voltage
21	$\overline{\text{POL}}$	Polarity bar input logic
22	$\overline{\text{LE}}$	Latch enable bar input logic
23	NC	No connect
24	DOUT	Data out
25	NC	No connect
26	VBIAS	Level translator bias voltage
27	HVGND	High voltage ground
28	BP	High voltage backplane output
29	HV _{OUT} 16	High voltage push-pull output
30	HV _{OUT} 15	High voltage push-pull output
31	HV _{OUT} 14	High voltage push-pull output
32	HV _{OUT} 13	High voltage push-pull output

32-Lead QFN Package Outline (K6)

5x5mm body, 1.0mm height (max), 0.50mm pitch

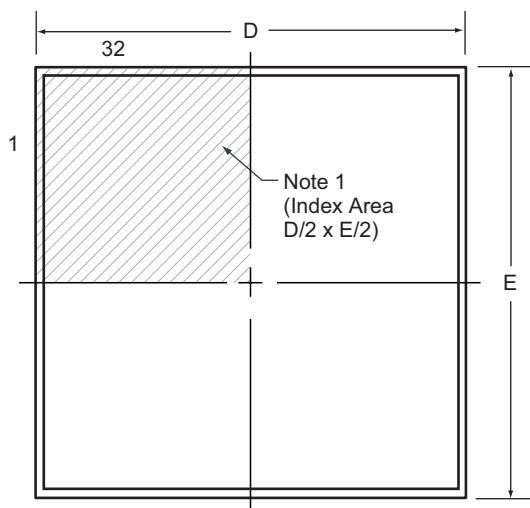

Top View

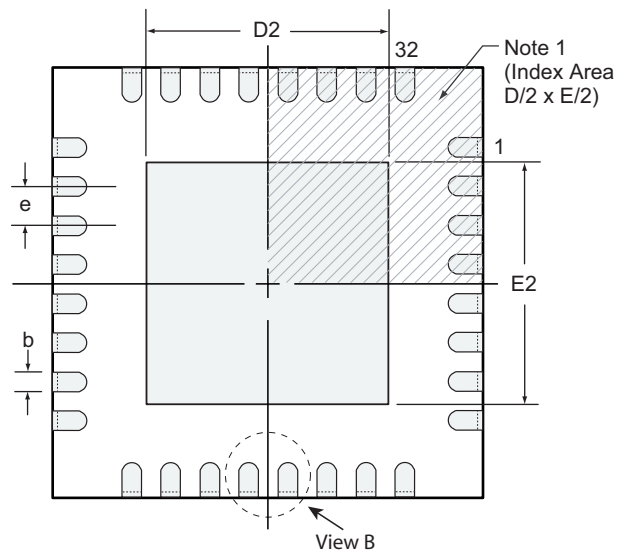

Bottom View

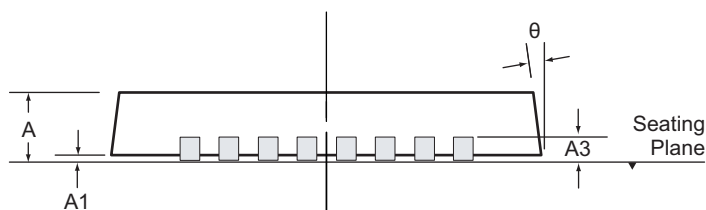

Side View

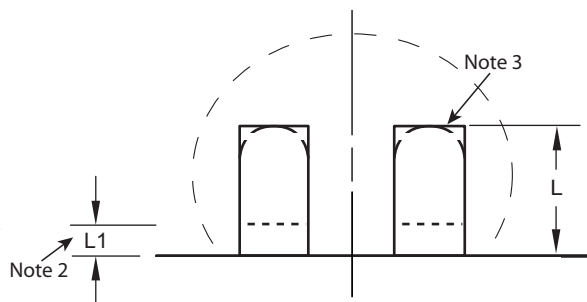

View B

Notes:

1. Details of Pin 1 identifier are optional, but must be located within the indicated area. The Pin 1 identifier may be either a mold, or an embedded metal or marked feature.
2. Depending on the method of manufacturing, a maximum of 0.15mm pullback (L1) may be present.
3. The inner tip of the lead may be either rounded or square.

Symbol		A	A1	A3	b	D	D2	E	E2	e	L	L1	θ
Dimension (mm)	MIN	0.80	0.00	0.20 REF	0.18	4.85	3.20	4.85	3.20	0.50 BSC	0.30	0.00	0°
	NOM	0.90	0.02		0.25	5.00	-	5.00	-		0.40	-	-
	MAX	1.00	0.05		0.30	5.15	3.70	5.15	3.70		0.50	0.15	14°

JEDEC Registration MO-220, Variation VHHD-5, Issue K, June 2006.

Drawings not to scale.

(The package drawing(s) in this data sheet may not reflect the most current specifications. For the latest package outline information go to <http://www.supertex.com/packaging.html>.)

Supertex inc. does not recommend the use of its products in life support applications, and will not knowingly sell its products for use in such applications, unless it receives an adequate "product liability indemnification insurance agreement". **Supertex** does not assume responsibility for use of devices described and limits its liability to the replacement of the devices determined defective due to workmanship. No responsibility is assumed for possible omissions or inaccuracies. Circuitry and specifications are subject to change without notice. For the latest product specifications, refer to the **Supertex** website: <http://www.supertex.com>.