

DAC729

Ultra-High Resolution 18-BIT DIGITAL-TO-ANALOG CONVERTER

FEATURES

- 16-BIT LINEARITY GUARANTEED (K Grade)
- USER ADJUSTABLE TO 18-BIT LINEARITY
- PRECISION INTERNAL REFERENCE
- FAST SETTLING, LOW NOISE INTERNAL OP AMP
- LOW DRIFT
- HERMETIC 40-PIN CERAMIC PACKAGE
- I_{OUT} OR V_{OUT} OPERATION

DESCRIPTION

The DAC729 sets the standard in very high accuracy digital-to-analog conversion. It is supplied from the factory at a guaranteed linearity of 16 bits, and is user-adjustable to 18-bit linearity (1LSB = FSR/262144).

To attain this high level of accuracy, the design takes advantage of Burr-Brown's thin-film monolithic DAC process, dielectric op amp process, hybrid capabilities, and advanced test and laser-trim techniques.

The DAC729 hybrid layout is specifically partitioned to minimize the effects of external load-current-induced thermal errors. The op amp design consists of a fast settling precision op amp with a current buffer within the feedback loop. This buffer isolates the load from the precision op amp, which results in a fast settling (8 μ s to 16 bits) output. The standard 40-pin package offers full hermeticity, contributing to the excellent reliability of the DAC729.

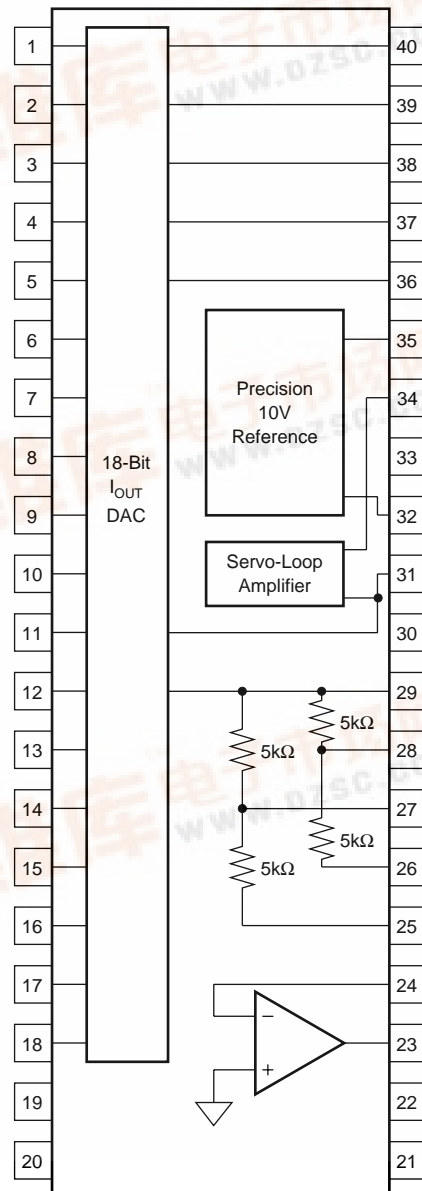

SPECIFICATIONS

ELECTRICAL

At $T_A = +25^\circ\text{C}$, $V_{CC} = \pm 15\text{V}$, $V_{DD} = +5\text{V}$, using internal reference op amp, unless otherwise noted. COB = $\pm 10\text{V FSR}$, CSB = $0\text{V to } +10\text{V FSR}$.

PARAMETER	DAC729JH			DAC729KH			UNITS
	MIN	TYP	MAX	MIN	TYP	MAX	
DIGITAL INPUT							
Resolution		18			*	*	Bits
Digital Inputs ⁽¹⁾ : V_{IH}	+2.4		$+V_L$	*		*	V
V_{IL}	0		+0.8	*		*	V
$I_{IH}, V_{IN} = +2.7\text{V}$			+5			*	μA
$I_{IL}, V_{IN} = +0.4\text{V}$			-300			*	μA
TRANSFER CHARACTERISTICS⁽²⁾							
ACCURACY							
Linearity Error ⁽³⁾			± 0.0015			± 0.00076	% of FSR ⁽⁴⁾
Differential Linearity Error			± 0.003			± 0.0015	% of FSR
Gain Error ⁽⁵⁾		± 0.05	± 0.10		*	*	%
Offset Error: ⁽⁵⁾ Voltage, COB ⁽⁶⁾		± 5	± 10		*	*	mV
CSB ⁽⁶⁾		± 3	± 5		*	*	mV
Current, COB			± 5			*	μA
CSB			± 1			*	μA
Power Supply Sensitivity, Unipolar: $\pm 15\text{VDC}$		± 0.0001	± 0.0005		*	*	% of FSR/% V_S
+5VDC		± 0.0001	± 0.0005		*	*	% of FSR/% V_S
Bipolar Offset: $\pm 15\text{VDC}$		± 0.0004	± 0.0015		*	*	% of FSR/% V_S
+5VDC		± 0.0001	± 0.0005		*	*	% of FSR/% V_S
Bipolar Gain: $\pm 15\text{VDC}$		± 0.0005	± 0.0015		*	*	% of FSR/% V_S
+5VDC		± 0.0001	± 0.0005		*	*	% of FSR/% V_S
Output Noise (10Hz to 100kHz), Voltage: Bipolar Offset		29			*		μVrms
Bipolar Gain		37			*		μVrms
Current: Bipolar Offset		2.9			*		nArms
Bipolar Gain		3			*		nArms
Monotonicity (0°C to $+70^\circ\text{C}$)	15	16		16	17		Bits
Differential Linearity Adjustment Resolution ⁽⁷⁾		18			*		Bits
DRIFT (Over Specification Temperature Range)							
Gain Drift (Excluding Reference Drift)		± 3	± 5		*	*	ppm/ $^\circ\text{C}$
Offset Drift (Excluding Reference Drift): COB (Bipolar)		± 2	± 5		*	*	ppm of FSR/ $^\circ\text{C}$
CSB (Unipolar)		± 2	± 3		*	*	ppm of FSR/ $^\circ\text{C}$
Linearity Error (at 0°C and $+70^\circ\text{C}$)		± 0.3	± 1		± 0.3	± 0.5	ppm of FSR/ $^\circ\text{C}$
Differential Linearity Error (at 0°C and $+70^\circ\text{C}$)		± 0.5	± 2		± 0.5	± 1	ppm of FSR/ $^\circ\text{C}$
STABILITY, LONG TERM (at $+25^\circ\text{C}$)							
Gain (Exclusive of Reference)		± 5			± 5		ppm/1000hr
Offset: COB (Exclusive of Reference)		± 5			± 5		ppm of FSR/1000hr
CSB		± 5			± 5		ppm of FSR/1000hr
Linearity		± 2			± 2		ppm of FSR/1000hr
Reference		± 5			± 5		ppm/1000hr
OUTPUT							
VOLTAGE OUTPUT MODE							
Ranges: COB		$\pm 2.5, \pm 5, \pm 10$				*	V
CSB		0 to +10, 0 to +5				*	V
Output Current	± 5			*			mA
Output Impedance		0.15			*		Ω
Short Circuit Duration		Indefinite to Common			Indefinite to Common		
CURRENT OUTPUT MODE							
COB Ranges		± 1			*		mA
Output Impedance		2.86			*		k Ω
CSB Ranges		0 to -2			*		mA
Output Impedance		4.0			*		k Ω
Output Current Tolerance			± 0.1			*	% of FSR
Compliance Voltage		-1 to +5			*		V
SETTLING TIME ($T_o \pm 0.00076\%$ of FSR) ⁽⁸⁾							
Voltage (Load = $2\text{k}\Omega \parallel 100\text{pF}$): Full-Scale Step		5	8		*	*	μs
1LSB Step (Major Carry) ⁽⁹⁾		4	7		*	*	μs
Slew Rate		20			*		V/ μs
Switching Transient Peak		500			*		mV
Switching Transient Energy		0.45			*		V- μs
Current Full-Scale Step ($2\text{mA} \times 10\Omega \parallel 1\text{pF}$)		300			*		ns

SPECIFICATIONS (CONT)

ELECTRICAL

At $T_A = +25^\circ\text{C}$, $V_{CC} = \pm 15\text{V}$, $V_{DD} = +5\text{V}$, using internal reference op amp, unless otherwise noted. COB = $\pm 10\text{V FSR}$, CSB = $0\text{V to } +10\text{V FSR}$.

PARAMETER	DAC729JH			DAC729KH			UNITS
	MIN	TYP	MAX	MIN	TYP	MAX	
REFERENCE							
Output (pin 32) : Voltage	+9.990	+10.000	+10.010	*	*	*	V
Source Current ⁽¹⁰⁾			+4			*	mA
Temperature Coefficient		± 2	± 4		*	*	ppm/ $^\circ\text{C}$
Short-Circuit Duration		Indefinite to Common				*	
Power Supply Sensitivity		0.00025	0.003		*	*	%/V
POWER SUPPLY REQUIREMENTS							
Voltage: $+V_{CC}$	+13.5	+15	+16.5	*	*	*	V
$-V_{CC}$	-16.5	-15	-13.5	*	*	*	V
V_{DD}	+4.75	+5	+5.25	*	*	*	V
Current: $+V_{CC}$		+30	+40		*	*	mA
$-V_{CC}$		-45	-60		*	*	mA
V_{DD}		+18	+25		*	*	mA
Power Dissipation (Rated Supplies)		1.22	1.63		*	*	W
ENVIRONMENTAL SPECIFICATIONS							
Temperature Range: Specification	0		+70	*		*	$^\circ\text{C}$
Storage	-60		+150	*		*	$^\circ\text{C}$

* Specifications same as DAC729JH.

NOTES: (1) TTL- and CMOS-compatible. (2) Specified for V_{OUT} mode using the internal op amp. (3) $\pm 0.00076\%$ of full-scale range is 1/2LSB for 16-bit resolution. (4) FSR means full-scale range, 20V for $\pm 10\text{V}$ range, etc. (5) Adjustable to zero error with an external potentiometer. (6) COB is complementary offset binary (bipolar); CSB is complementary straight binary (unipolar). (7) Using the MSB adjustment circuit, the user may improve the DAC linearity to 1/2LSB of this specification with gain and offset errors adjusted to zero at 25°C . (8) Maximum represents 3 σ limit, not 100% production tested. (9) At the major carry; 20000 to 1FFFF_{HEX} and from 1FFFF to 20000_{HEX}. (10) Maximum with no degradation in specifications. External loads must be constant.

ABSOLUTE MAXIMUM RATINGS⁽¹⁾

V_{DD} to Common	0V to +7V
$+V_{CC}$ to Common	0V to +18V
$-V_{CC}$ to Common	0V to -18V
Digital Data Inputs (pins 1-18) to Common	-0.5V to V_{DD}
Reference Voltage In (pin 31)	+9V to +11V
Reference Out (pin 32) to Common	Indefinite Short to Common
External Voltage Applied to D/A Output (pin 29)	-5V to +5V
External Voltage Applied to Feedback Resistors (pins 25, 26, 27, 28)	-15V to +15V
V_{OUT} (pin 23)	Indefinite Short to Common
Power Dissipation	3000mW
Storage Temperature	-60 $^\circ\text{C}$ to +150 $^\circ\text{C}$
Lead Temperature (soldering, 10s)	+300 $^\circ\text{C}$

NOTE: (1) Stresses above those listed under "Absolute Maximum Ratings" may cause permanent damage to the device. Exposure to absolute maximum conditions for extended periods may affect device reliability.

ORDERING INFORMATION

PRODUCT	PACKAGE	TEMPERATURE RANGE
DAC729JH	40-Pin Hermetic DIP	0 $^\circ\text{C}$ to +70 $^\circ\text{C}$
DAC729KH	40-Pin Hermetic DIP	0 $^\circ\text{C}$ to +70 $^\circ\text{C}$
DAC729KH-BI	40-Pin Hermetic DIP	0 $^\circ\text{C}$ to +70 $^\circ\text{C}$

PACKAGE INFORMATION

PRODUCT	PACKAGE	PACKAGE DRAWING NUMBER ⁽¹⁾
DAC729JH	40-Pin Hermetic DIP	214
DAC729KH	40-Pin Hermetic DIP	214
DAC729KH-BI	40-Pin Hermetic DIP	214

NOTE: (1) For detailed drawing and dimension table, please see end of data sheet, or Appendix C of Burr-Brown IC Data Book.

PIN CONNECTIONS

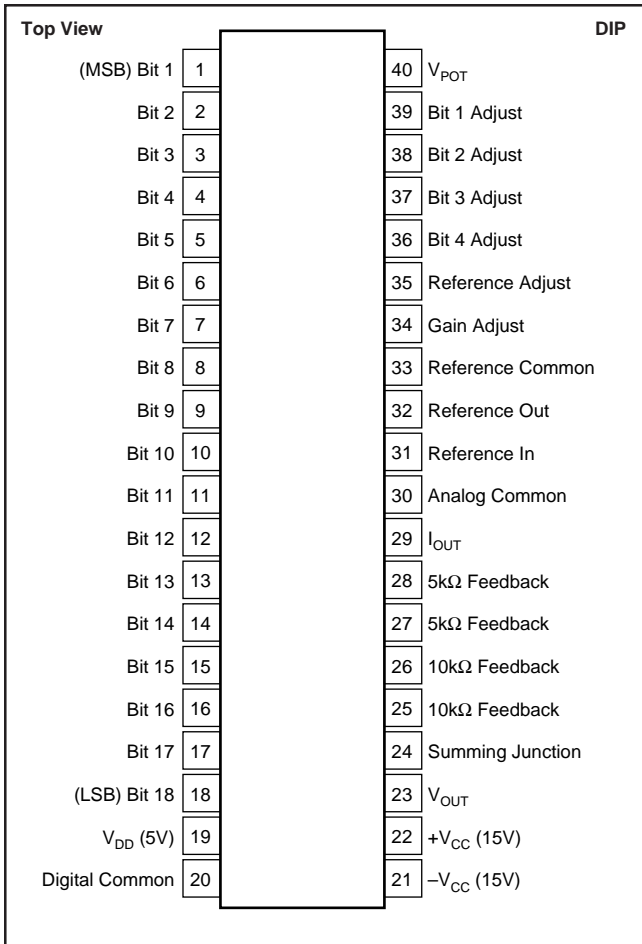



ELECTROSTATIC DISCHARGE SENSITIVITY

Any integral circuit can be damaged by ESD. Burr-Brown recommends that all integrated circuits be handled with appropriate precautions. Failure to observe proper handling and installation procedures can cause damage.

ESD damage can range from subtle performance degradation to complete device failure. Precision integrated circuits may be more susceptible to damage because very small parametric changes could cause the device not to meet published specifications.

BURN-IN SCREENING

Burn-in screening is an option available for the DAC729 family of products. Burn-in duration is 160 hours at 100°C (or equivalent combination of time and temperature).

All units are tested after burn-in to ensure that grade specifications are met.

THEORY OF OPERATION

The DAC729 is an 18-bit digital-to-analog converter system, including a precision reference, low noise, fast settling operational amplifier, and an 18-bit current source/DAC chip contained in a hermetic 40-pin ceramic dual-in-line package. Refer to Figure 11 for a schematic diagram of the DAC729.

THE INTERNAL REFERENCE

The reference consists of a very low temperature coefficient closed-loop reference zener circuit that has been temperature-drift-compensated by laser-trimming a zener current to achieve less than 1ppm/°C temperature drift of V_{REF} .

By strapping pin 32 (Reference Out) to pin 31 (Reference In), the DAC will be properly biased from the internal reference. The internal reference may be fine adjusted using pin 35 as shown in Figure 7. The reference has an output buffer that will supply 4mA for use external to the DAC729. This load must remain constant because changing load on the reference may change the reference current to the DAC.

In systems where several components need to track the same system reference, the DAC729 may be used with an external 10V reference, however, the internal reference has lower noise (6μVp-p) and better stability than other references available.

THE OPERATIONAL AMPLIFIER

To support a DAC of this accuracy, the operational amplifier must have a maximum gain-induced error of less than 1/3LSB, independent of output swing (the op amp must be linear!) To support 15 bits (1/2-bit linearity), the op amp must have a gain of 130,000V/V. For 18 bits, the minimum

gain is well over 500,000V/V. Since thermal feedback is the major limitation of gain for mono op amps, the amplifier was designed as a high gain, fast settling mono op amp, followed by a monolithic, unity-gain current buffer to isolate the thermal effects of external loads from the input stage gain transistors. The op amp and buffer are separated from the DAC chip, minimizing thermally-induced linearity errors in the DAC circuit. The op amp, like the reference, is not dedicated to the DAC729. The user may want to add a network, or select a different amplifier. The DAC729 internal op amp is intended to be the best choice for accuracy, settling time, and noise.

THE DAC CHIP

The heart of the DAC729 is a monolithic current source and switch integrated circuit. The absolute linearity, differential linearity, and the temperature performance of the DAC729 are the result of the design, which utilizes the excellent element matching of the current sources and switch transistors to each other, and the tracking of the current setting resistors to the feedback resistors. Older discrete designs cannot achieve the performance of this monolithic DAC design.

The two most significant bits are binarily weighted interdigitated current sources. The currents for bits 3 through 18 are scaled with both current source weighting and an R-2R ladder. The circuit design is optimized for low noise and low superposition error, with the current sources arranged to minimize both code-dependent thermal errors and IR drop errors. As a result, the superposition errors are typically less than 20μV.

The DAC chip is biased from a servo amplifier feeding into the base line of the current sources. This servo amplifier sets the collector current to be mirrored and scaled in the DAC chip current sources, as shown in Figure 11. The reference current for the servo is established by the reference voltage applied to pin 31 feeding an internal resistor (20kΩ) to the virtual ground of the servo amplifier.

DISCUSSION OF SPECIFICATIONS

DIGITAL INPUT CODES

The DAC729 accepts complementary digital input codes in either binary format (CSB for Unipolar or COB for Bipolar; see Table I).

DIGITAL INPUT	DAC ANALOG OUTPUT			
	COB	20V FSR	CSB	10V FSR
00 0000 0000 0000 0000	+ Full Scale	9.999924V	+ Full Scale	9.999962V
11 1111 1111 1111 1111	- Full Scale	-10V	- Full Scale	0V

TABLE I. Digital Input Coding.

ACCURACY

Linearity

This specification describes one of the most important measures of performance of a D/A converter. Linearity error is the deviation of the analog output versus code transfer function from a straight line drawn through the end points (all bits ON point and all bits OFF point).

Differential Linearity Error

Differential Linearity Error (DLE) of a D/A converter is the deviation from an ideal 1LSB change in the output from one adjacent output state to the next. A differential linearity error specification of $\pm 1/2$ LSB means that the output step sizes can be between $1/2$ LSB and $3/2$ LSB when the input changes from one adjacent input state to the next. A negative DLE specification of no more than -1 LSB (-0.0015% for 16-bit resolution) insures monotonicity to 16 bits.

Monotonicity

Monotonicity assures that the analog output will increase or remain the same for increasing input digital codes. The DAC729KH is specified to be monotonic to 16 bits over the entire specification temperature range.

DRIFT

Gain Drift

Gain drift is a measure of the change in the full-scale range output over temperature expressed in parts per million per degree centigrade (ppm/ $^{\circ}$ C). Gain drift is measured by: (1) testing the end point differences for each D/A at t_{MIN} , $+25^{\circ}$ C, and t_{MAX} ; (2) calculating the gain error with respect to the $+25^{\circ}$ C value; and (3) dividing by the temperature change.

Offset Drift

Offset drift is a measure of the change in the output with 3FFFF_H applied to the digital inputs over the specified temperature range. The maximum change in offset at t_{MIN} or t_{MAX} is referenced to the offset error at $+25^{\circ}$ C and is divided by the temperature change. This drift is expressed in parts per million of full-scale range per degree centigrade (ppm of FSR/ $^{\circ}$ C).

SETTLING TIME

Settling time of the D/A is the total time required for the analog output to settle within an error band around its final value after a change in digital input. Settling time includes the slew time of the op amp.

Voltage Output

Settling times are specified to $\pm 0.00076\%$ of FSR scale range change of 20V (COB) or 10V (CSB) and a 1LSB change at the “major carry,” the point at which the worst-case settling time occurs. (This is the worst-case point since all of the input bits change when going from one code to the next.)

Current Output

Settling times are specified to $\pm 0.00076\%$ of FSR for a full-scale range change with an output load resistance of 10Ω .

COMPLIANCE VOLTAGE

Compliance voltage applies only to the current output mode of operation. It is the maximum voltage swing allowed on the output current pin while still being able to maintain specified linearity.

POWER SUPPLY SENSITIVITY

Power supply sensitivity is a measure of the effect of a change in a power supply voltage on the D/A converter full-scale output. It is defined as a percent of FSR change in the output per percent of change in either the positive supply ($+V_{CC}$), negative supply ($-V_{CC}$), or logic supply (V_{DD}) about the nominal power supply voltages (see Figure 1). It is specified for DC or low frequency changes. The typical performance curve in Figure 1 shows the effect of high frequency changes in power supply voltages using internal reference, DAC, and op amp.



FIGURE 1. Power Supply Sensitivity vs Frequency Using Internal Reference and Op Amp.

OPERATING INSTRUCTIONS

POWER SUPPLY CONNECTIONS

For optimum performance and noise rejection, power supply decoupling capacitors should be added as shown in Figure 2. These capacitors ($1\mu\text{F}$ to $10\mu\text{F}$ tantalum recommended) should be located at the DAC729.

EXTERNAL OFFSET AND GAIN ADJUSTMENT

Offset and gain may be trimmed by installing external offset and gain potentiometers. Connect these potentiometers as shown in Figure 3 and adjust as described below. TCR of the potentiometers should be $100\text{ppm}/^{\circ}\text{C}$ or less. The $3.9\text{M}\Omega$ and $510\text{k}\Omega$ resistors (20% carbon or better) should be located close to the DAC729 to prevent noise pickup. If it is not convenient to use these high-value resistors, an equivalent “T” network, as shown in Figure 4, may be substituted in place of the $3.9\text{M}\Omega$. A $0.001\mu\text{F}$ to $0.01\mu\text{F}$ capacitor should be connected from Gain Adjust (pin 34) to

common to shunt noise pickup. This capacitor should be a low leakage film type (such as Mylar™ or Teflon™).

Refer to Figures 5 and 6 for relationship of offset and gain adjustments to unipolar and bipolar D/A converters.

OFFSET ADJUSTMENT

For unipolar (CSB) configurations, apply the digital input code that should produce zero potential output and adjust the offset potentiometer for zero output.

For bipolar (COB) configurations, apply the digital input code that should produce the maximum negative output voltage. See Table II for corresponding codes and Figures 2 and 3 for offset adjustment connections. Offset adjust should be made prior to gain adjust.

Mylar™, Teflon™ E.I. du Pont de Nemours & Co.

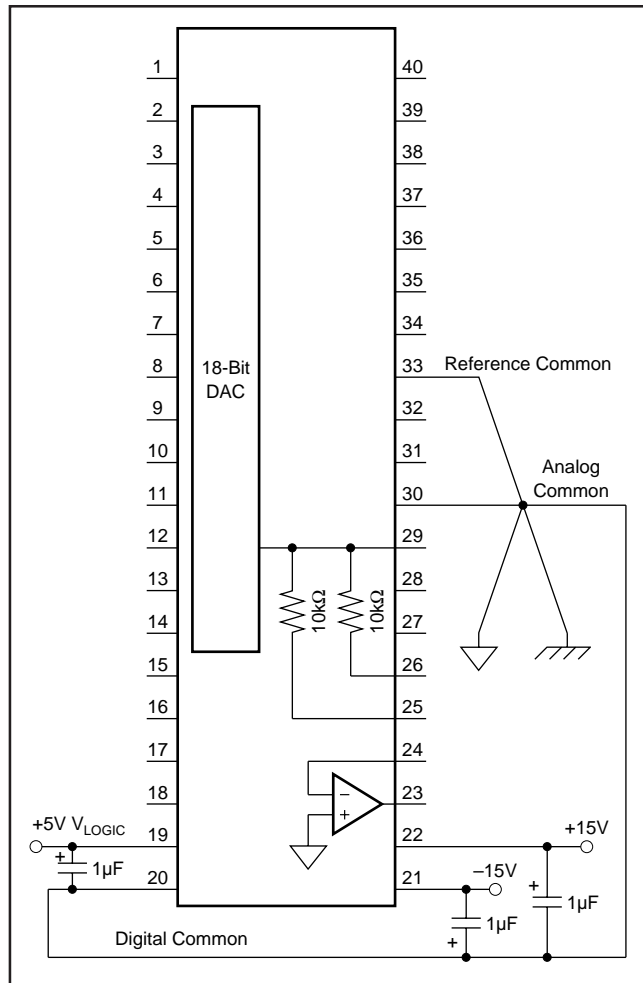

FIGURE 2. Ground Connections and Supply Bypass.

GAIN ADJUSTMENT

For either unipolar or bipolar configurations, apply the digital input that should give the maximum positive output voltage. Adjust the gain potentiometer for this positive full-scale voltage. See Table II for positive full-scale voltages and Figure 3 for gain adjustment connections.

OUTPUT RANGE	CODE	CONNECT PIN 23	CONNECT PIN 31	CONNECT PIN 24	GAIN ADJUST	
					16-BITS	18-BITS
±10V	COB	to Pin 25	to Pin 26	to Pin 29	9.9969V	9.99992V
±5V	COB	to Pin 27	to Pin 26	to Pin 29	4.9998V	9.99996V
±2.5V	COB	to Pin 27	to Pin 26	to Pins 29 & 25	2.4992V	2.49998V
0 to 10V	CSB	to Pins 25 & 26	N/C	to Pin 29	9.9998V	9.99996V
0 to 5V	CSB	to Pins 27 & 28	N/C	to Pin 29	4.9999V	4.99998V

TABLE II. Output Range Connections and Gain Adjust Voltage.

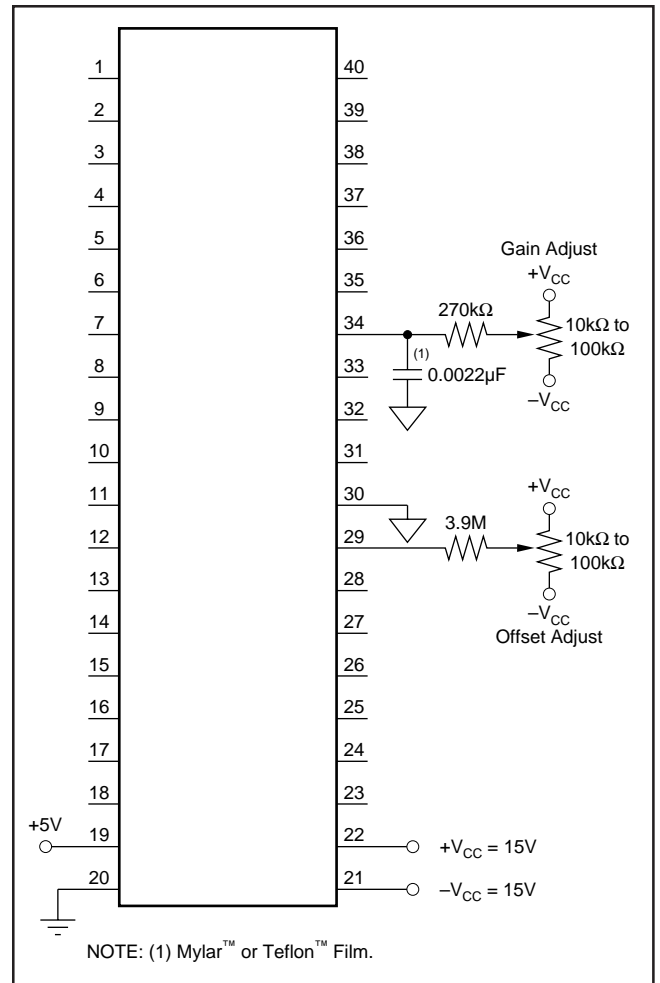

FIGURE 3. Gain and Offset Adjust Hook-Up.

NOTE: (1) Mylar™ or Teflon™ Film.

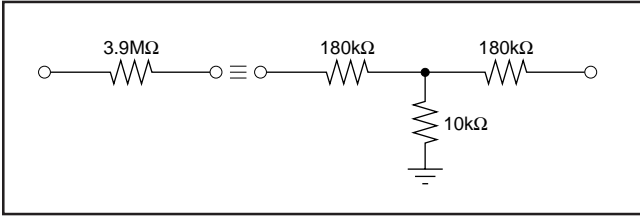

FIGURE 4. Equivalent Resistances.

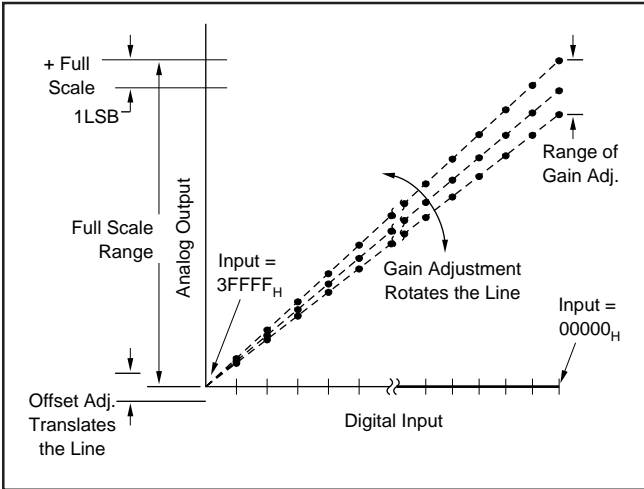

FIGURE 5. Relationship of Offset and Gain Adjustments for a Unipolar D/A Converter.

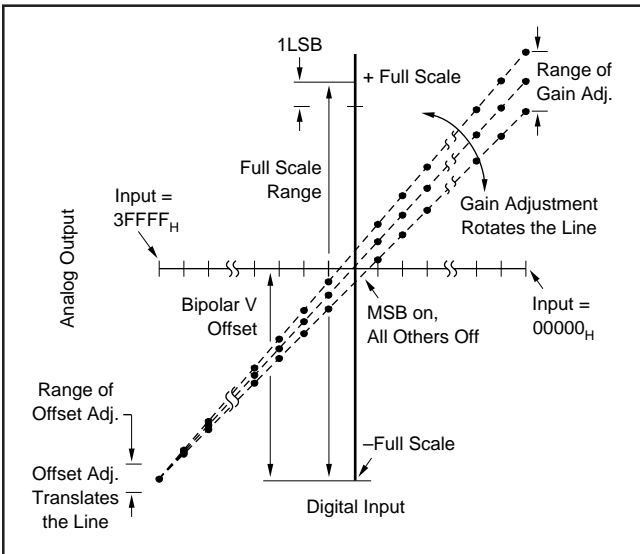

FIGURE 6. Relationship of Offset and Gain Adjustments for a Bipolar D/A Converter.

REFERENCE ADJUSTMENT

The internal reference may be fine adjusted using pin 35 as shown in Figure 7. Adjusting the reference has a similar effect on the DAC as gain adjust, except the transfer characteristic rotates around bipolar zero for a bipolar connection as shown in Figure 8.

LAYOUT/APPLICATIONS SUGGESTIONS

Obviously, the management of IR drops, power supply noise, thermal stability, and environmental noise becomes

much more critical as the accuracy of the system increases. The DAC729 has been designed to minimize these applications problems to a large degree. The basics of “Kelvin sensing” and “holy point” grounding will be the most important considerations in optimizing the absolute accuracy of the system. Figure 9 shows the proper connection of the DAC with the holy-point ground and the Kelvin-sensed-output connection at the load.

The DAC729 has three separate supply common (ground) pins. Reference common (pin 33) carries the return current from the internal reference and the output I/V converter common. The current in pin 33 is stable and independent of code or load. Digital common (pin 20) carries the variable currents of the biasing circuits. Analog common (pin 30) is the termination of the R-2R ladder and also carries the “waste current” from the off side of the current switches. These three ground pins must be star connected to system ground for the DAC to bias properly and accurately. Good ground connections are essential, because an IR drop of just $39\mu\text{V}$ completely swamps out a 10V FSR 18-bit LSB.

When the application is such that the DAC must control loads of greater than $\pm 5\text{mA}$ with rated accuracy, it is recommended that an external op amp or op amp buffer combination be used to dissipate the variable power external to the DAC729. This minimizes the temperature variations on the precision D/A converter. Figure 10 illustrates a method of connecting the external amplifier for $\pm 10\text{V}$ operation, while using an external reference.

When driving loads to greater than $\pm 10\text{V}$, care must be taken that the internal resistors are never exposed to greater than $\pm 10\text{V}$, and that the summing junction is clamped to insure that the voltage never exceeds $\pm 5\text{V}$. Clamping the summing junction with diodes (parallel opposing connection) to ground will give the best transient response and settling times.

TRUE 18-BIT PERFORMANCE (Differential Linearity Adjustment)

To take full advantage of the DAC729’s accuracy, the four MSBs have adjustment capabilities. A simplified schematic (Figure 11) shows the internal structure of the DAC current source and the adjustment input terminal. The suggested network for adjusting the linearity is shown in Figure 12. This circuit has nearly twice the range that is required for the DAC729JH. The range is intentionally narrow so as to minimize the effect of temperature drift or stability problems in the potentiometers. The potentiometers are biased in an identical fashion to the internal DAC current sources to minimize power supply sensitivity and drift over temperature. Low leakage capacitors such as Mylar or Teflon film are essential.

The linearity adjustment requires a digital voltmeter with 7 digits of resolution on the 10V range ($1\mu\text{V}$ resolution) and excellent linearity. For the DAC, 1LSB of the 0V to 10V scale (10 FSR) is $38\mu\text{V}$. To be $1/2\text{LSB}$ linear, the measurement must resolve $19\mu\text{V}$. The meter must be properly calibrated and linear to 1ppm of range.

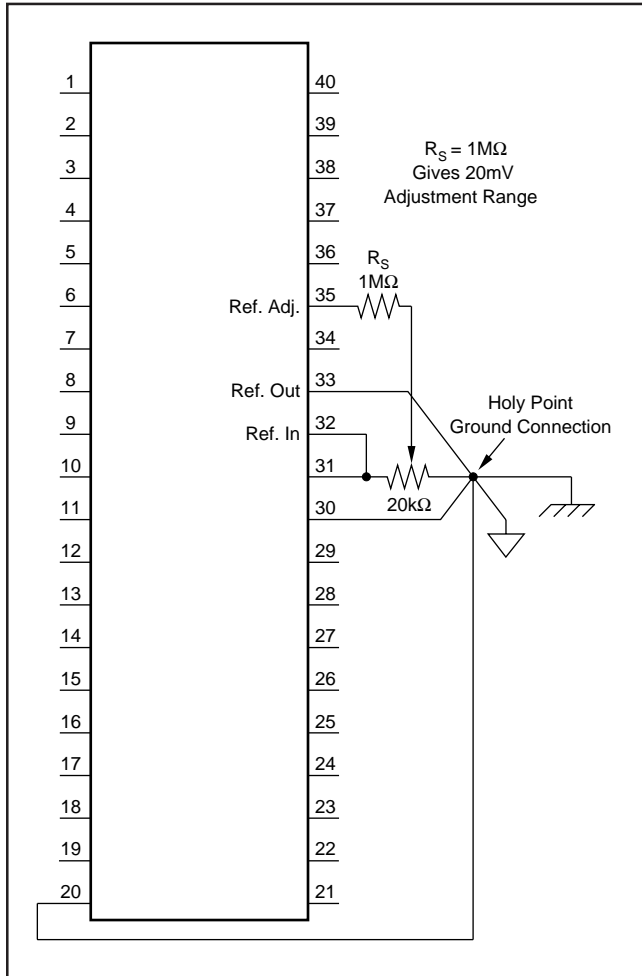

FIGURE 7. V_{REF} Adjust.

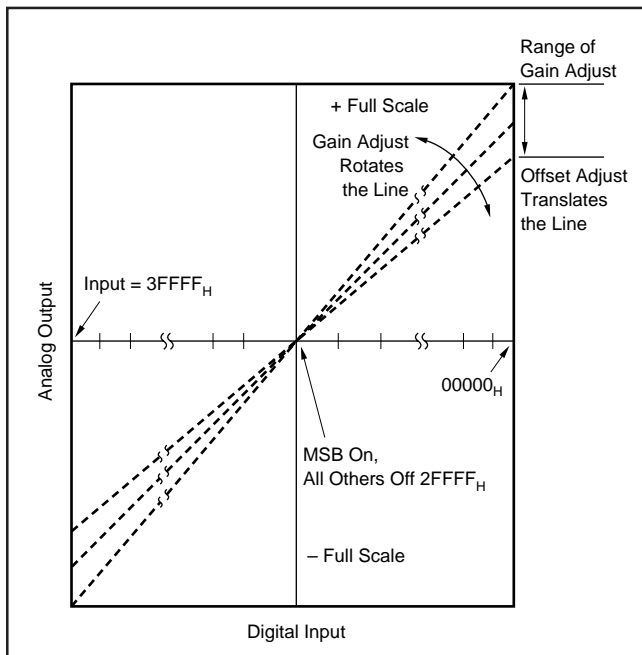

FIGURE 8. Effect of V_{REF} Adjust on a COB Connected DAC729.

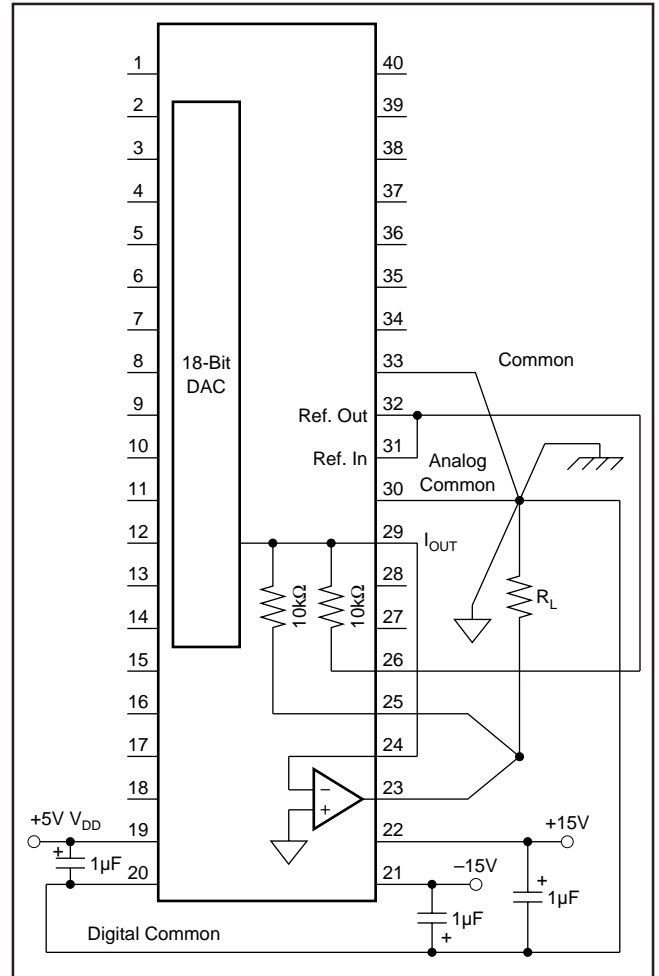

FIGURE 9. Typical Hook-Up Diagram with “Holy Point” Ground and Kelvin Sense Load, Using Internal Op Amp and Reference.

With the DAC connected for 0 to 10V output (Figure 13), the adjustment procedure is to set the DAC code and measure as follows:

FOURTH MSB ADJUSTMENT (Pin 36)

1. Set Code = 11 1100 0000 0000 0000
2. Measure V_{OUT}
3. Set Code = 11 1011 1111 1111 1111
4. Measure V_{OUT} and record the difference.
5. Adjust 4th MSB potentiometer to make difference +38 μ V.
6. Repeat steps 1 through 5 to confirm.

THIRD MSB ADJUSTMENT (Pin 37)

1. Set Code = 11 1000 0000 0000 0000
2. Measure V_{OUT}
3. Set Code = 11 0111 1111 1111 1111
4. Measure V_{OUT} and record the difference.
5. Adjust 3rd MSB potentiometer to make difference +38 μ V.
6. Repeat steps 1 through 5 to confirm.

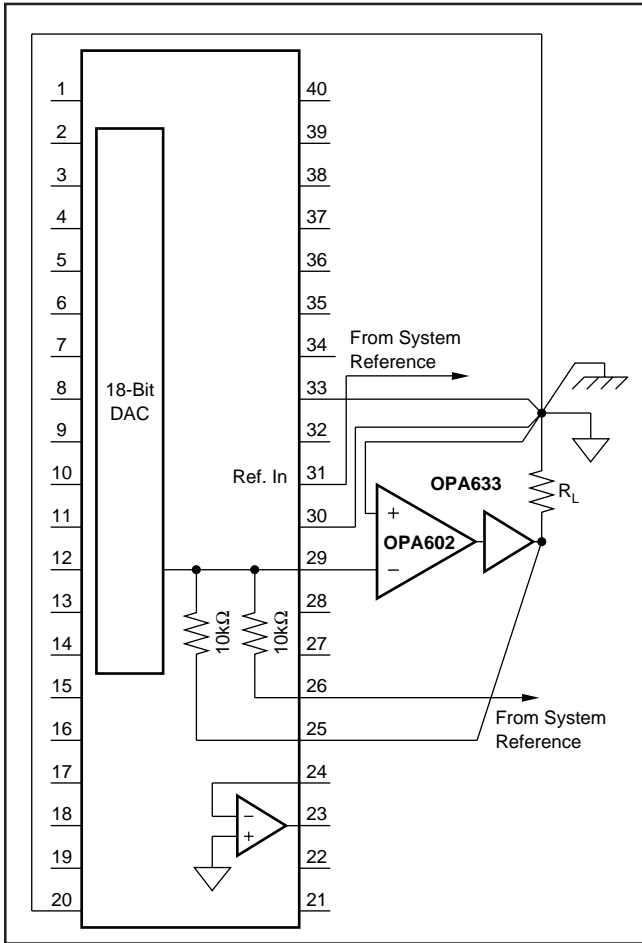

FIGURE 10. Using an External Op Amp with Buffer and External Reference for $\pm 10V$ Output.

SECOND MSB ADJUSTMENT (Pin 38)

1. Set Code = 11 0000 0000 0000 0000
2. Measure V_{OUT}
3. Set Code = 10 1111 1111 1111 1111
4. Measure V_{OUT} and record the difference.
5. Adjust 2nd MSB potentiometer to make difference $+38\mu V$.
6. Repeat steps 1 through 5 to confirm.

MSB ADJUSTMENT (Pin 39)

1. Set Code = 10 0000 0000 0000 0000
2. Measure V_{OUT}
3. Set Code = 01 1111 1111 1111 1111
4. Measure V_{OUT} and record the difference.
5. Adjust the MSB potentiometer to make difference $+38\mu V$.
6. Repeat steps 1 through 5 to confirm.

APPLICATIONS

The DAC729 is the DAC of choice for applications requiring very high resolution, accuracy, and wide dynamic range.

DIGITAL AUDIO

The excellent linearity and differential linearity are ideal for PCM professional audio and waveform generation applications.

FIGURE 11. DAC729 Simplified Schematic.

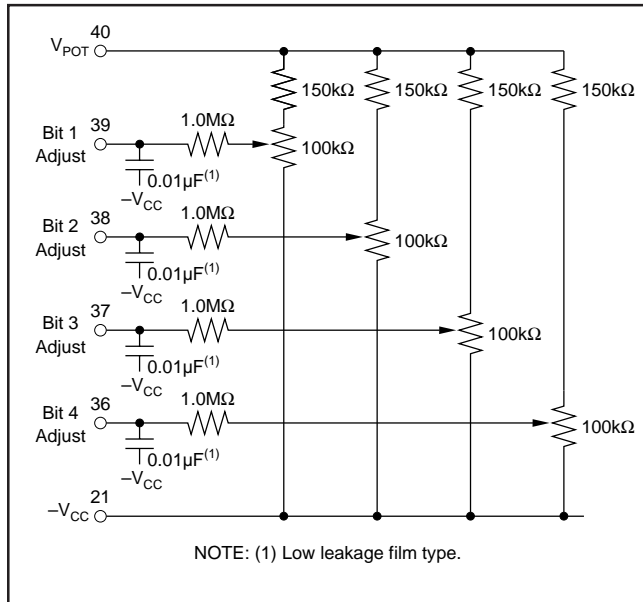

FIGURE 12. Differential Linearity Adjustment Circuit for the 4MSBs.

The DAC729 offers superb dynamic range. Dynamic range is a measure of the ratio of the smallest signals the converter can produce to the full-scale range, usually expressed in decibels (dB). The theoretical dynamic range of a converter is approximately 6dB per bit. For the DAC729 the theoretical range is 108dB! The actual dynamic range is limited by noise (signal-to-noise) and linearity errors. The DAC729's 6μV typical noise floor, fast settling op amp, and adjustable 18-bit linearity minimize the limitation.

Total harmonic distortion (THD) is the measure of the magnitude and distribution of the linearity error, differential linearity error, noise, and quantization error. The THD is defined as the ratio of the square root of the sum of the squares of the harmonics to the values of the input fundamental frequency. The rms value of a DAC error can be shown to be

$$\epsilon_{\text{RMS}} = \sqrt{\frac{1}{n} \sum_{i=1}^n [E_L(i) + E_Q(i)]^2}$$

where n is the number of samples in one cycle of any given sine wave, $E_L(i)$ is the linearity error of the DAC729 at each sampling point, and $E_Q(i)$ is the quantization error at each sampling point. The THD can then be expressed as

$$\text{THD} = \frac{\epsilon_{\text{RMS}}}{E_{\text{RMS}}} = \frac{\sqrt{\frac{1}{n} \sum_{i=1}^n [E_L(i) + E_Q(i)]^2}}{E_{\text{RMS}}} \times 100\%(2)$$

where E_{RMS} is the rms signal-voltage level.

This expression indicates that, in general, there is a correlation between the THD and the square root of the sum of the squares of the linearity errors at each digital word of interest. However, this expression does not mean that the worst-case linearity error of the D/A is directly correlated to the THD.

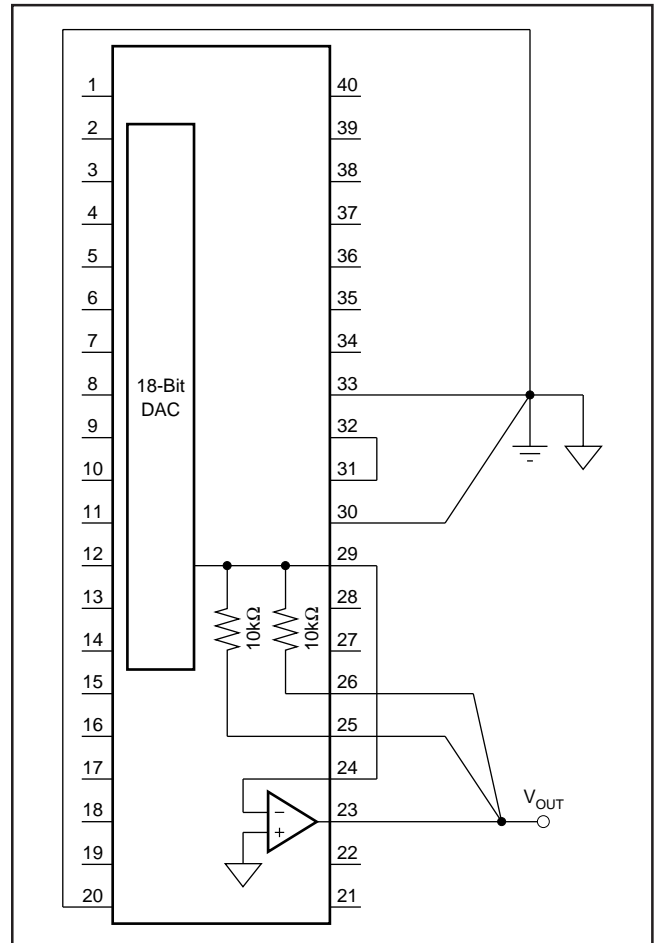

FIGURE 13. 0 to 10V FSR.

The DAC729 has demonstrated THD of 0.0009% at full scale (at 1kHz). This is the level of distortion that is desired to test other professional audio products, making the DAC729 ideal for professional audio test equipment.

The ability to adjust the linearity of the 4MSBs, the 18-bit resolution, fast settling and low noise give the DAC729 unmatched performance.

AUTOMATIC TEST EQUIPMENT

The pin functions of the DAC729 are convenient for use in automatic test equipment systems. The ability to use internal or external reference and internal or external op amp means versatility for the system designer. For example, in automatic test systems with several DACs and ADCs, it is desirable to operate all of the high accuracy converters from the same reference, improving the tracking characteristics of those components to one another. The reference in the DAC729 is a very stable precision reference, and is suitable for use as the system reference.

Test systems, and other large systems are the ideal application for a DAC of this accuracy, because the DAC will be calibrated in the environment in which it will be used. Since the environment is very stable, the manual calibration (Figure 12) may be adequate. However, highly automated systems will go to an automatic calibration routine. Replacing

the potentiometers in Figure 12 with V_{OUT} DACs, and using sample and difference measurements, the major carry bit weights can be measured, and external DACs used to adjust the differential linearity of the DAC729. A successive approximation routine yields the fastest calibration. The output voltage of the external DACs will have to be level shifted, as the bit adjustment potentiometer must be able to achieve $-V_{CC}$ to give the full adjust range.

Because the DAC729 feedback resistors have a tolerance of $\pm 0.1\%$, the output range can be rescaled slightly with small-value fixed external resistors to give convenient ranges. A popular range is 0V to +10.24V which gives even 5mV steps at 11 bits. In this case, the LSB size is $39.06\mu V$. Figure 14 shows how to connect two 240Ω resistors in series with the internal $10k\Omega$ resistors to give a 0V to 10.24V full-scale range. Another convenient range might be 0V to +10.48576V which gives an even $40\mu V$ LSB step size.

THE HEART OF AN 18-BIT ADC

The DAC729 makes a good building block in ADC applications. The key to ADC accuracy is differential linearity of the DAC. The ability to adjust to 18-bit linearity, coupled with the fast settling time of the DAC729 makes the design cycle for an 18-bit successive approximation ADC much faster, and the production more consistent. Figure 15 shows the DAC as the heart of a successive approximation ADC. The clock and successive approximation register could be implemented in 7400 series TTL, as a simple gate-array or standard cell, or part of a local processor.

With the DAC out of the way, the comparator is the toughest part of the ADC design. To resolve an 18-bit LSB, and interface to a TTL-logic device, the comparator must have a gain of $500kV/V$ (5X actual) as well as low hysteresis, low noise, and low thermally induced offsets. With this much gain, a slow comparator may be desired to reduce the risk of instability.

The feedback resistors of the DAC are the input scaling resistors of the ADC. An OPA602 and an OPA633 make an excellent buffer for the input signal, giving a very high input impedance to the signal (minimizing IR drop) while maintaining the linearity.

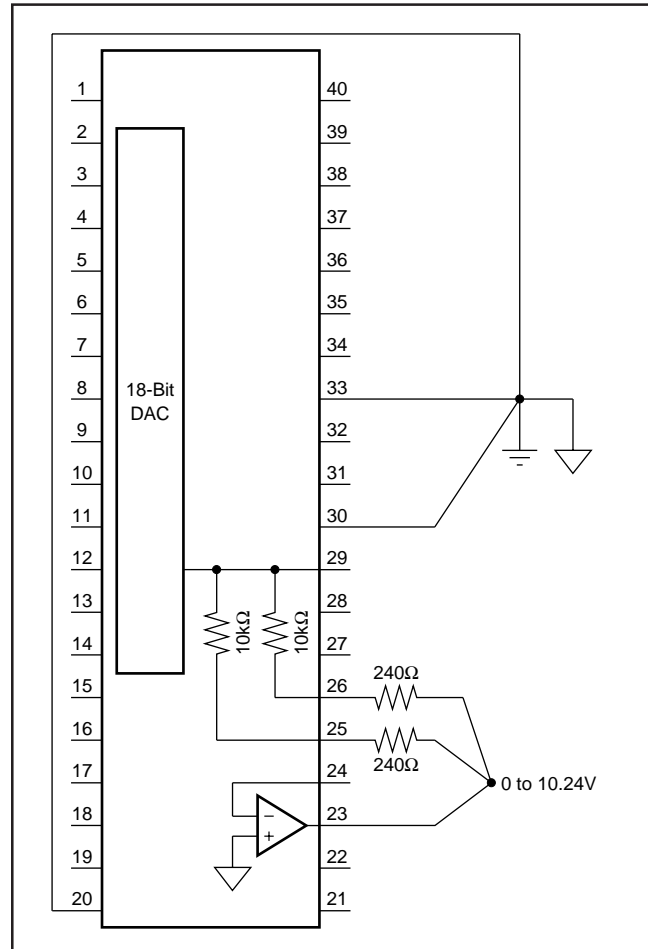

FIGURE 14. 0V to 10.24V Using Internal Op Amp and Internal Reference.

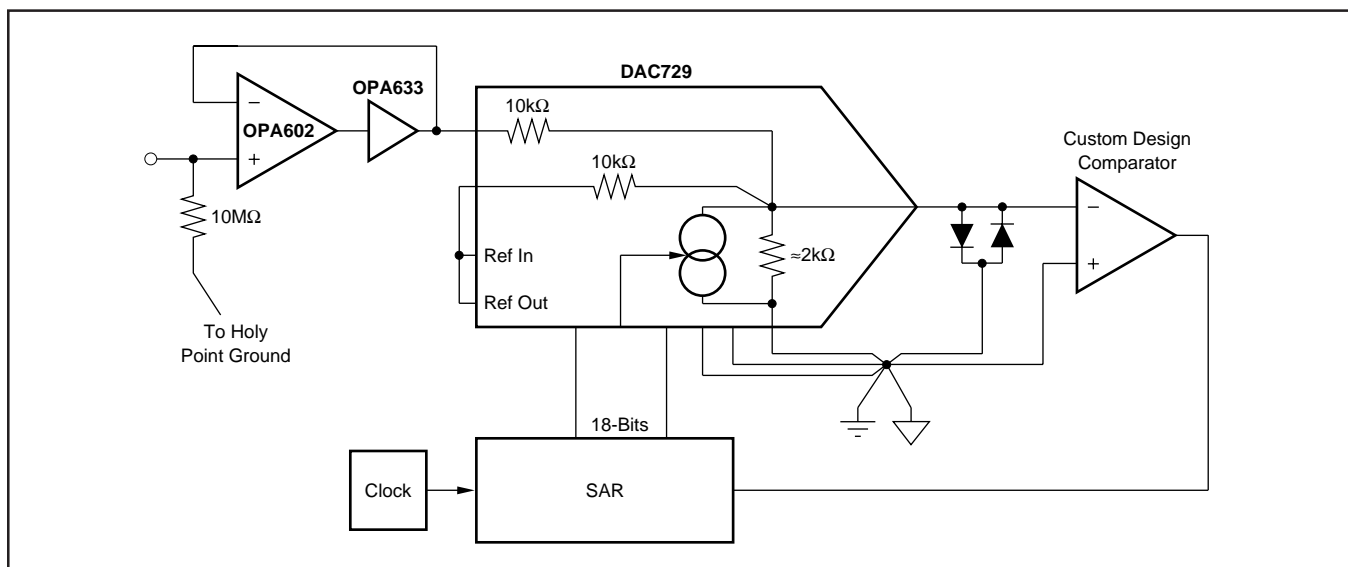

FIGURE 15. Block Diagram of an 18-Bit Resolution $\pm 10V_{IN}$ ADC.