

ZXCT1009

HIGH-SIDE CURRENT MONITOR

DESCRIPTION

The ZXCT1009 is a high side current sense monitor. Using this device eliminates the need to disrupt the ground plane when sensing a load current.

It takes a high side voltage developed across a current shunt resistor and translates it into a proportional output current.

A user defined output resistor scales the output current into a ground-referenced voltage.

The wide input voltage range of 20V down to as low as 2.5V make it suitable for a range of applications. A minimum operating current of just 4 μ A, combined with its SOT23 package make it a unique solution for portable battery equipment.

FEATURES

- Low cost, accurate high-side current sensing
- Output voltage scaling
- Up to 2.5V sense voltage
- 2.5V – 20V supply range
- 4 μ A quiescent current
- 1% typical accuracy
- SOT23 and SM8 packages

APPLICATIONS

- Battery chargers
- Smart battery packs
- DC motor control
- Over current monitor
- Power management
- Level translating
- Programmable current source

APPLICATION CIRCUIT

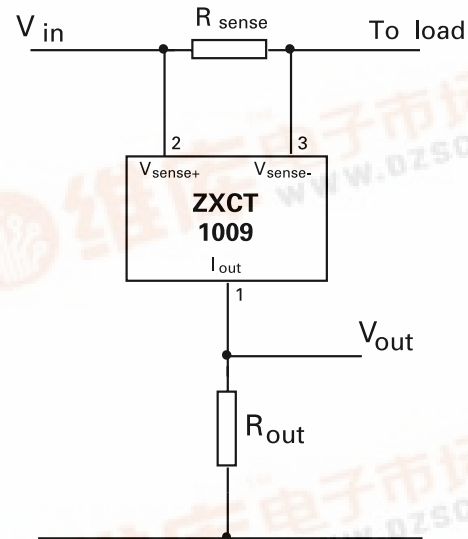

ORDERING INFORMATION

DEVICE	REEL SIZE	TAPE WIDTH	QUANTITY PER REEL	PARTMARKING	PACKAGE
ZXCT1009FTA	7"	8mm	3,000 units	109	SOT23
ZXCT1009T8TA	7"	12mm	1,000 units	ZXCT1009	SM8

ZXCT1009

ABSOLUTE MAXIMUM RATINGS

Voltage on any pin	-0.6V to 20V (relative to I _{out})
Continuous output current	25mA
Continuous sense voltage	$V_{in} + 0.5V > V_{sense}^{\dagger} > V_{in} - 5V$
Operating temperature	-40 to 85°C
Storage temperature	-55 to 125°C
Package power dissipation	(T _A = 25°C)
SOT23	450mW - derate to zero at 125°C
SM8	2W

Operation above the absolute maximum rating may cause device failure. Operation at the absolute maximum ratings for extended periods may reduce device reliability.

ELECTRICAL CHARACTERISTICS

Test Conditions T_A = 25°C, V_{in} = 5V, R_{out} = 100Ω.

SYMBOL	PARAMETER	CONDITIONS	LIMITS			UNIT
			Min	Typ	Max	
V _{in}	V _{CC} range		2.5		20	V
I _{out} ¹	Output current	V _{sense} =0V	1	4	15	μA
		V _{sense} =10mV	90	104	120	μA
		V _{sense} =100mV	0.975	1.002	1.025	mA
		V _{sense} =200mV	1.95	2.0	2.05	mA
		V _{sense} =1V	9.6	9.98	10.2	mA
V _{sense} [†]	Sense voltage		0		2500	mV
I _{sense} ⁻	V _{sense} - input current				100	nA
Acc	Accuracy	R _{sense} = 0.1Ω V _{sense} =200mV	-2.5		2.5	%
G _m	Transconductance, I _{out} / V _{sense}			10000		μA/V
BW	Bandwidth	RF P _{in} = -20dBm‡		300		kHz
		V _{sense} = 10mV dc V _{sense} = 100mV dc		2		MHz

¹ Includes input offset voltage contribution

[†] V_{sense}=V_{in}-V_{load}

‡ -20dBm=63mVp-p into 50Ω

TYPICAL CHARACTERISTICS

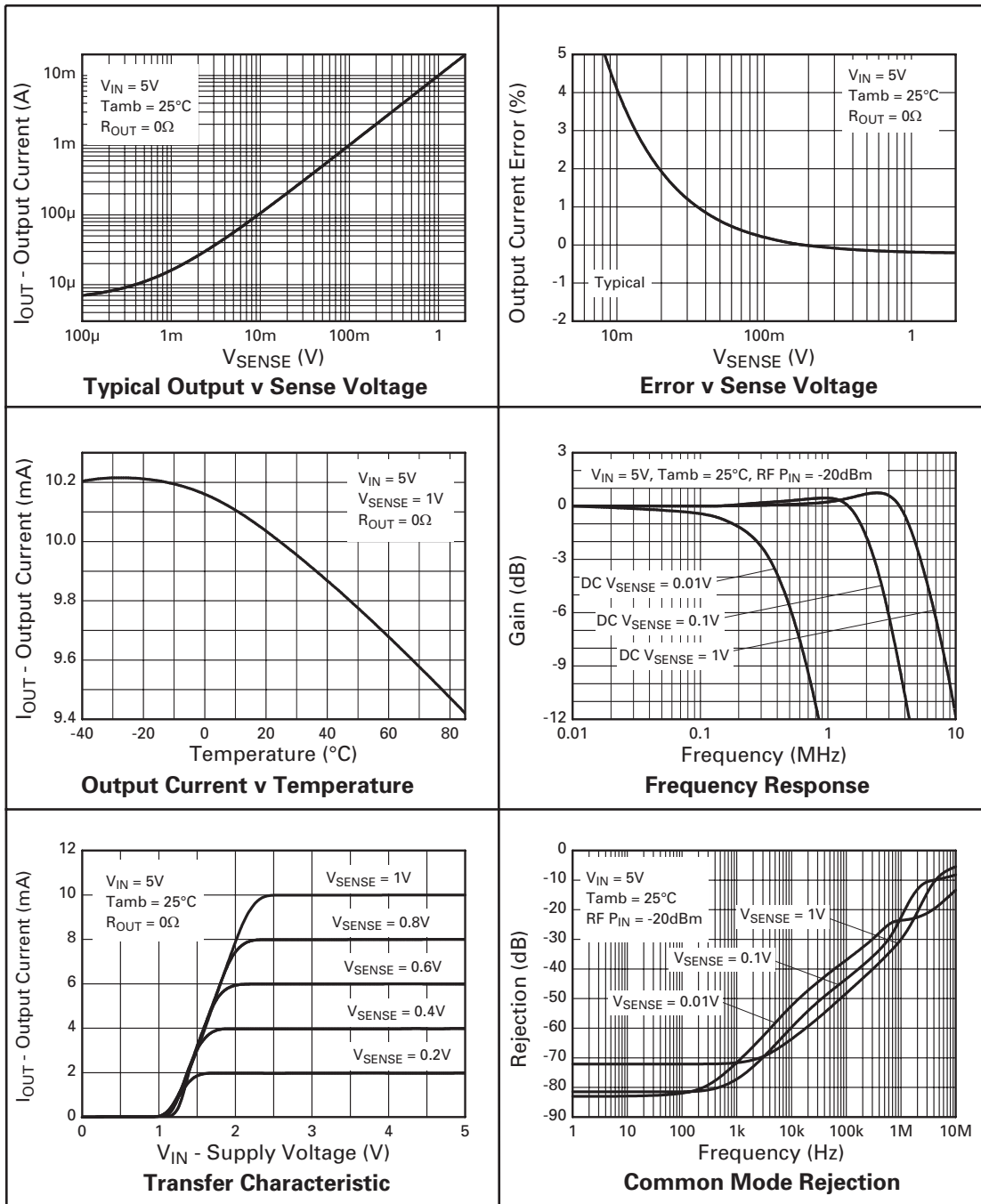

ZXCT1009

TYPICAL CHARACTERISTICS (Cont.)

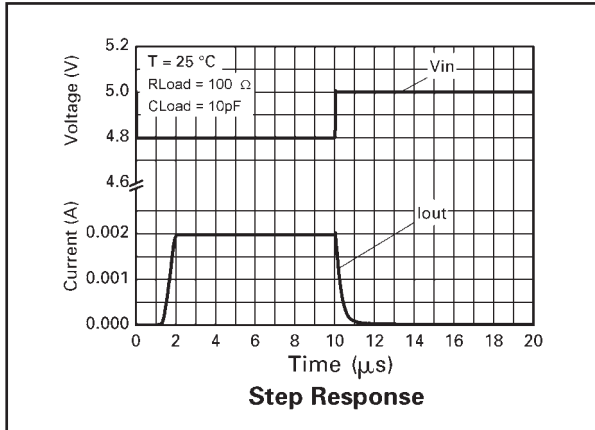

SCHEMATIC DIAGRAM

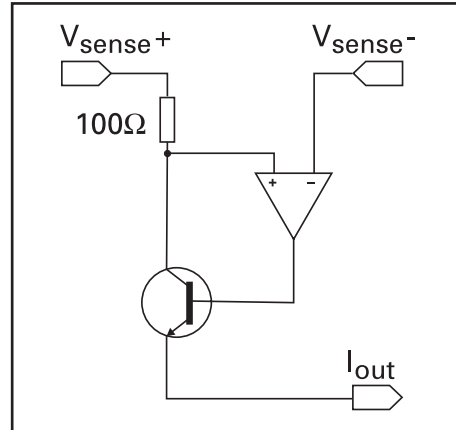

PIN DESCRIPTION

Pin Name	Pin Function
V_{sense+}	Supply voltage
V_{sense-}	Connection to load/battery
I_{out}	Output current, proportional to $V_{in} - V_{load}$

CONNECTION DIAGRAMS

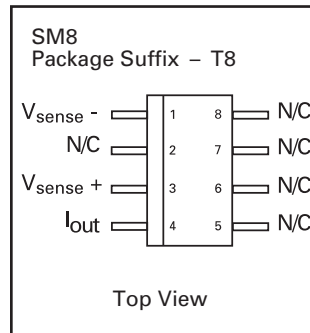
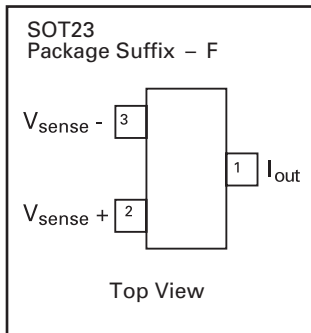

ZXCT1009

POWER DISSIPATION

The maximum allowable power dissipation of the device for normal operation (P_{max}), is a function of the package junction to ambient thermal resistance (θ_{ja}), maximum junction temperature (T_{jmax}), and ambient temperature (T_{amb}), according to the expression:

$$P_{max} = (T_{jmax} - T_{amb}) / \theta_{ja}$$

The device power dissipation, P_D is given by the expression:

$$P_D = I_{out} \cdot (V_{in} - V_{out}) \text{ Watts}$$

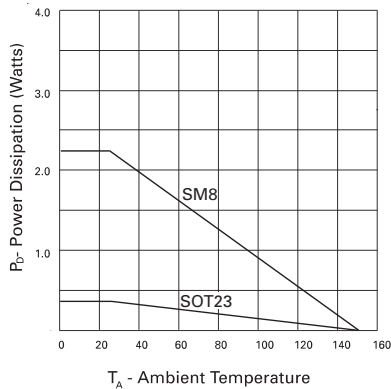

APPLICATIONS INFORMATION

The following lines describe how to scale a load current to an output voltage.

$$V_{sense} = V_{in} - V_{load}$$

$$V_{out} = 0.01 \times V_{sense} \times R_{out}^1$$

E.g.

A 1A current is to be represented by a 100mV output voltage:

1) Choose the value of R_{sense} to give $50mV > V_{sense} > 500mV$ at full load.

For example $V_{sense} = 100mV$ at 1.0A. $R_{sense} = 0.1/1.0 \Rightarrow 0.1$ ohms.

2) Choose R_{out} to give $V_{out} = 100mV$, when $V_{sense} = 100mV$.

Rearranging ¹ for R_{out} gives:
 $R_{out} = V_{out} / (V_{sense} \times 0.01)$

$$R_{out} = 0.1 / (0.1 \times 0.01) = 100 \Omega$$

TYPICAL CIRCUIT APPLICATION

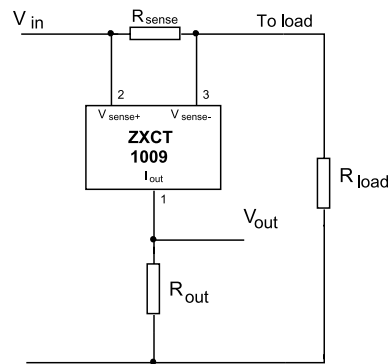

Where R_{load} represents any load including DC motors, a charging battery or further circuitry that requires monitoring, R_{sense} can be selected on specific requirements of accuracy, size and power rating.

ZXCT1009

APPLICATIONS INFORMATION (Continued)

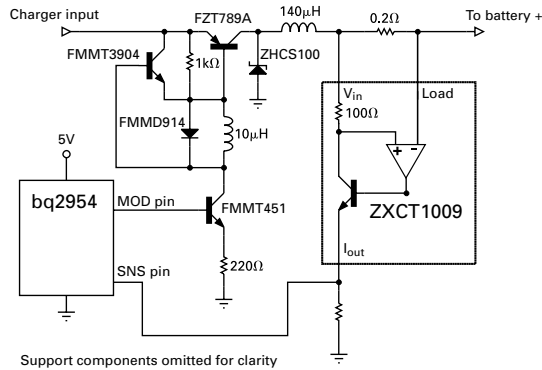

Li-Ion Charger Circuit

The above figure shows the ZXCT1009 supporting the Benchmark bq2954 Charge Management IC. Most of the support components for the bq2954 are omitted for clarity. This design also uses the Zetex FZT789A high current Super-β PNP as the switching transistor in the DC-DC step down converter and the FMMD451 as the drive NPN for the FZT789A. The circuit can be configured to charge up to four Li-Ion cells at a charge current of 1.25A. Charge can be terminated on maximum voltage, selectable minimum current, or maximum time out. Switching frequency of the PWM loop is approximately 120kHz.

The ZXCT1009 is intended as a direct functional replacement for the ZDS1009, which is featured in a complete design from Unirode/Texas Instruments on the Li-Ion charger circuit shown above. Reference: DVS2954S1H Li-Ion Charger Development System.

Transient Protection

An additional resistor, R_{lim} can be added in series with R_{out} (figure 1.0), to limit the current from I_{out} . Any circuit connected to V_{out} will be protected from input voltage transients. This can be of particular use in automotive applications where load dump and other common transients need to be considered.

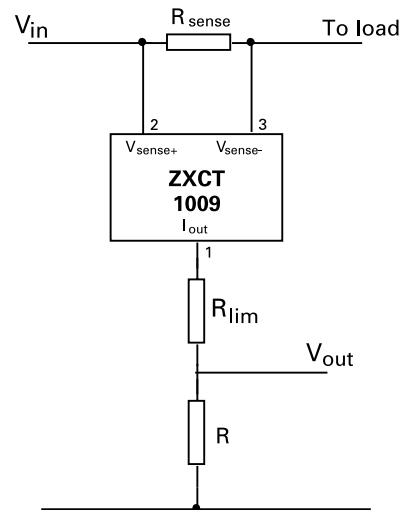

Figure 1.0
ZXCT1009 with additional current limiting Resistor R_{lim} .

Assuming the worst case condition of $V_{out} = 0V$; providing a low impedance to a transient, the minimum value of R_{lim} is given by:-

$$R_{lim}(\min) = \frac{V_{pk} - V_{max}}{I_{pk}}$$

V_{pk} = Peak transient voltage to be withstood
 V_{max} = Maximum working Voltage = 20V
 I_{pk} = Peak output current = 40mA

The maximum value of R_{lim} is set by $V_{in}(\min)$, $V_{out}(\max)$ and the dropout voltage (see transfer characteristic on page 3) of the ZXCT1009 :-

$$R_{lim}(\max) = \frac{R_{out}[V_{in}(\min) - (V_{dp} + V_{out}(\max))]}{V_{out}(\max)}$$

$V_{in}(\min)$ = Minimum Supply Operating Voltage
 V_{dp} = Dropout Voltage
 $V_{out}(\max)$ = Maximum Operating Output Voltage

APPLICATIONS INFORMATION (Continued)

ZXCT1009

PCB trace shunt resistor for low cost solution

The figure below shows output characteristics of the device when using a PCB resistive trace for a low cost solution in replacement for a conventional shunt resistor. The graph shows the linear rise in voltage across the resistor due to the PTC of the material and demonstrates how this rise in resistance value over temperature compensates for the NTC of the device.

The figure opposite shows a PCB layout suggestion. The resistor section is 25mm x 0.25mm giving approximately 150mΩ using 1oz copper. The data for the normalised graph was obtained using a 1A load current and a 100Ω output resistor. An electronic version of the PCB layout is available at www.zetex.com/isense.

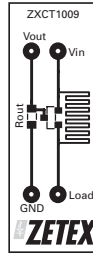

Actual Size

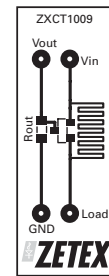

Layout shows area of shunt resistor compared to SOT23 package. Not actual size

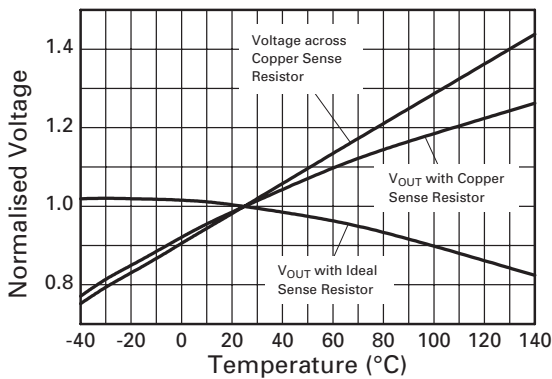

Effect of Sense Resistor Material on Temperature Performance

ZXCT1009

PACKAGE DIMENSIONS SOT23

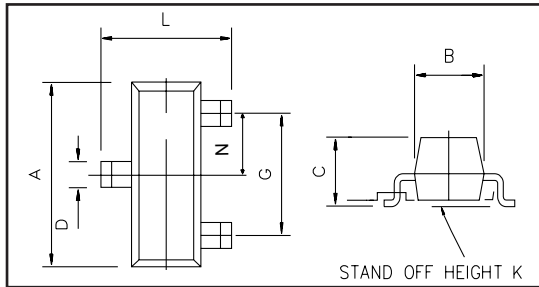

DIM	Millimeters		Inches	
	Min	Max	Min	Max
A	2.67	3.05	0.105	0.120
B	1.20	1.40	0.047	0.055
C	-	1.10	-	0.043
D	0.37	0.53	0.0145	0.021
F	0.085	0.15	0.0033	0.0059
G	NOM 1.9		NOM 0.075	
K	0.01	0.10	0.0004	0.004
L	2.10	2.50	0.0825	0.0985
N	NOM 0.95		NOM 0.037	

PACKAGE DIMENSIONS SM8

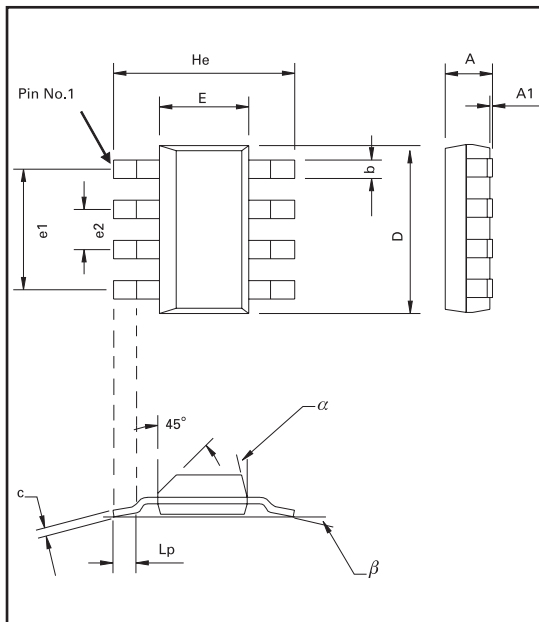

DIM	Millimeters			Inches		
	Min	Typ	Max	Min	Typ	Max
A	-	-	1.7	-	-	0.067
A1	0.02	-	0.1	0.0008	-	0.004
b	-	0.7	-	-	0.028	-
c	0.24	-	0.32	0.009	-	0.013
D	6.3	-	6.7	0.248	-	0.264
E	3.3	-	3.7	0.130	-	0.145
e1	-	4.59	-	-	0.180	-
e2	-	1.53	-	-	0.060	-
He	6.7	-	7.3	0.264	-	0.287
Lp	0.9	-	-	0.035	-	-
alpha	-	-	15°	-	-	15°
beta	-	10°	-	-	10°	-

© Zetex Semiconductors plc 2005

Europe	Americas	Asia Pacific	Corporate Headquarters
Zetex GmbH Streitfeldstraße 19 D-81673 München Germany	Zetex Inc 700 Veterans Memorial Hwy Hauppauge, NY 11788 USA	Zetex (Asia) Ltd 3701-04 Metroplaza Tower 1 Hing Fong Road, Kwai Fong Hong Kong	Zetex Semiconductors plc Zetex Technology Park Chadderton, Oldham, OL9 9LL United Kingdom
Telefon: (49) 89 45 49 49 0 Fax: (49) 89 45 49 49 49 europa.sales@zetex.com	Telephone: (1) 631 360 2222 Fax: (1) 631 360 8222 usa.sales@zetex.com	Telephone: (852) 26100 611 Fax: (852) 24250 494 asia.sales@zetex.com	Telephone (44) 161 622 4444 Fax: (44) 161 622 4446 hq@zetex.com

These offices are supported by agents and distributors in major countries world-wide.

This publication is issued to provide outline information only which (unless agreed by the Company in writing) may not be used, applied or reproduced for any purpose or form part of any order or contract or be regarded as a representation relating to the products or services concerned. The Company reserves the right to alter without notice the specification, design, price or conditions of supply of any product or service.

For the latest product information, log on to www.zetex.com



ISSUE 9 - OCTOBER 2005