

## 400-mA, 1.25-MHz, HIGH-EFFICIENCY, STEP-DOWN CONVERTER IN THIN-SOT23

### FEATURES

- High-Efficiency Synchronous Step-Down Converter With up to 95% Efficiency
- 2.5-V to 6-V Input Voltage Range
- Adjustable Output Voltage Range From 0.7 V to  $V_I$
- Fixed Output Voltage Options Available
- Up to 400-mA Output Current
- 1.25-MHz Fixed Frequency PWM Operation
- Highest Efficiency Over Wide Load Current Range Due to Power-Save Mode
- 15- $\mu$ A Typical Quiescent Current
- Soft Start
- 100% Duty Cycle Low-Dropout Operation
- Dynamic Output-Voltage Positioning
- Available in TSOT23 Package

### APPLICATIONS

- PDAs and Pocket PC
- Cellular Phones, Smart Phones
- OMAP™ and Low Power DSP Supply
- Digital Cameras
- Portable Media Players
- Portable Equipment
- WLAN PC Cards

### DESCRIPTION

The TPS6222x devices are a family of high-efficiency, synchronous step-down converters ideally suited for portable systems powered by 1-cell Li-Ion or 3-cell NiMH/NiCd batteries. The devices are also suitable to operate from a standard 3.3-V or 5-V voltage rail.

With an output voltage range of 6 V down to 0.7 V and up to 400-mA output current, the devices are ideal for powering the low voltage TMS320™ DSP family and processors used in PDAs, pocket PCs, and smart phones. Under nominal load current, the devices operate with a fixed switching frequency of typically 1.25 MHz. At light load currents, the part enters the power-save mode operation; the switching frequency is reduced and the quiescent current is typically only 15  $\mu$ A; therefore, the device achieves the highest efficiency over the entire load current range. The TPS6222x needs only three small external components. Together with the tiny TSOT23 package, a minimum system solution size can be achieved. An advanced fast response voltage mode control scheme achieves superior line and load regulation with small ceramic input and output capacitors.

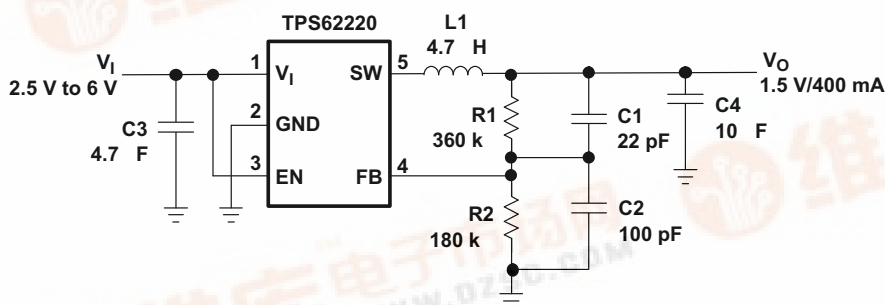

Typical Application (Adjustable Output Voltage Version)

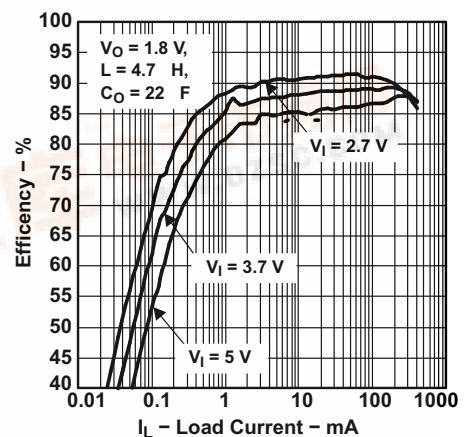

**TPS62220, TPS62221, TPS62222  
TPS62223, TPS62224, TPS62227  
TPS62228, TPS62229**



SLVS491D—SEPTEMBER 2003—REVISED MARCH 2006



These devices have limited built-in ESD protection. The leads should be shorted together or the device placed in conductive foam during storage or handling to prevent electrostatic damage to the MOS gates.

**ORDERING INFORMATION <sup>(1)</sup>**

T <sub>A</sub>	OUTPUT VOLTAGE	THIN-SOT23 PACKAGE	SYMBOL
-40°C to 85°C	Adjustable	TPS62220DDC	ALN
	1.5 V	TPS62221DDC	ALO
	1.6 V	TPS62224DDC	ALQ
	1.7 V	TPS62229DDC	EJ
	1.8 V	TPS62222DDC	APP
	1.875 V	TPS62228DDC	EH
	2.3 V	TPS62223DDC	ALX
	1.2 V	TPS62227DDC	BRZ

(1) The DDC package is available in tape and reel. Add R suffix (TPS62220DDCR) to order quantities of 3000 parts. Add T suffix (TPS62220DDCT) to order quantities of 250 parts.

**ABSOLUTE MAXIMUM RATINGS**

over operating free-air temperature (unless otherwise noted) <sup>(1)</sup>

		TPS6222x	UNIT
V <sub>I</sub>	Supply voltage on pin <sup>(2)</sup>	-0.3 to 7.0	V
	Voltages on pins SW, EN, FB <sup>(2)</sup>	-0.3 to V <sub>I</sub> +0.3	V
P <sub>D</sub>	Continuous power dissipation	See Dissipation Rating Table	
T <sub>J</sub>	Operating junction temperature range	-40 to 150	°C
T <sub>stg</sub>	Storage temperature	-65 to 150	°C
	Lead temperature (soldering, 10 sec)	260	°C

- (1) Stresses beyond those listed under "absolute maximum ratings" may cause permanent damage to the device. These are stress ratings only, and functional operation of the device at these or any other conditions beyond those indicated under "recommended operating conditions" is not implied. Exposure to absolute-maximum-rated conditions for extended periods may affect device reliability.
- (2) All voltage values are with respect to network ground terminal.

**DISSIPATION RATING TABLE <sup>(1)</sup>**

PACKAGE	T <sub>A</sub> ≤ 25°C POWER RATING	DERATING FACTOR ABOVE T <sub>A</sub> = 25°C	T <sub>A</sub> = 70°C POWER RATING	T <sub>A</sub> = 85°C POWER RATING
DDC	400 mW	4 mW/°C	220 mW	160 mW

(1) The thermal resistance junction to ambient of the 5-pin Thin-SOT23 is 250°C/W.

**RECOMMENDED OPERATING CONDITIONS**

		MIN	NOM	MAX	UNIT
V <sub>I</sub>	Supply voltage	2.5		6	V
V <sub>O</sub>	Output voltage range for adjustable output voltage version	0.7		V <sub>I</sub>	V
I <sub>O</sub>	Output current			400	mA
L	Inductor <sup>(1)</sup>	4.7			μH
C <sub>I</sub>	Input capacitor <sup>(1)</sup>		4.7		μF
T <sub>A</sub>	Operating ambient temperature	-40		85	°C
T <sub>J</sub>	Operating junction temperature	-40		125	°C

(1) See the application section for further information

## ELECTRICAL CHARACTERISTICS

 $V_I = 3.6\text{ V}$ ,  $V_O = 1.8\text{ V}$ ,  $I_O = 200\text{ mA}$ ,  $EN = VIN$ ,  $T_A = -40^\circ\text{C}$  to  $85^\circ\text{C}$ , typical values are at  $T_A = 25^\circ\text{C}$  (unless otherwise noted)

PARAMETER		TEST CONDITIONS	MIN	TYP	MAX	UNIT
<b>SUPPLY CURRENT</b>						
$V_I$	Input voltage range		2.5		6	V
$I_Q$	Operating quiescent current	$I_O = 0\text{ mA}$ , Device is not switching		15	25	$\mu\text{A}$
	Shutdown supply current	$EN = GND$		0.1	1	$\mu\text{A}$
	Undervoltage lockout threshold		1.5		2	V
<b>ENABLE</b>						
$V_{(EN)}$	EN high level input voltage		1.3			V
	EN low level input voltage				0.4	V
$I_{(EN)}$	EN input bias current	$EN = GND$ or $VIN$		0.01	0.1	$\mu\text{A}$
<b>POWER SWITCH</b>						
$r_{DS(on)}$	P-channel MOSFET on-resistance	$V_I = V_{GS} = 3.6\text{ V}$		530	670	$\text{m}\Omega$
		$V_I = V_{GS} = 2.5\text{ V}$		670	850	
	N-channel MOSFET on-resistance	$V_I = V_{GS} = 3.6\text{ V}$		430	540	$\text{m}\Omega$
		$V_I = V_{GS} = 2.5\text{ V}$		530	660	
$I_{lkg}$	P-channel leakage current	$V_{DS} = 6\text{ V}$		0.1	1	$\mu\text{A}$
	N-channel leakage current	$V_{DS} = 6\text{ V}$		0.1	1	$\mu\text{A}$
$I_{(LIM)}$	P-channel current limit	$2.5\text{ V} < V_I < 6\text{ V}$	600	670	880	mA
<b>OSCILLATOR</b>						
$f_S$	Switching frequency		0.8	1.25	1.85	MHz
<b>OUTPUT</b>						
$I_O$	Output current				400	mA
$V_O$	Adjustable output voltage range	TPS62220	0.7		$V_{IN}$	V
$V_{ref}$	Reference voltage			0.5		V
$V_O$	Feedback voltage, See (1)	TPS62220 Adjustable	$V_I = 3.6\text{ V}$ to $6\text{ V}$ , $I_O = 0\text{ mA}$	0%	3%	
			$V_I = 3.6\text{ V}$ to $6\text{ V}$ , $0\text{ mA} \leq I_O \leq 400\text{ mA}$	-3%	3%	
	1.5 V	TPS62221	$V_I = 2.5\text{ V}$ to $6\text{ V}$ , $I_O = 0\text{ mA}$	0%	3%	
			$V_I = 2.5\text{ V}$ to $6\text{ V}$ , $0\text{ mA} \leq I_O \leq 400\text{ mA}$	-3%	3%	
	1.6 V	TPS62224	$V_I = 2.5\text{ V}$ to $6\text{ V}$ , $I_O = 0\text{ mA}$	0%	3%	
			$V_I = 2.5\text{ V}$ to $6\text{ V}$ , $0\text{ mA} \leq I_O \leq 400\text{ mA}$	-3%	3%	
	1.7 V	TPS62229	$V_I = 2.5\text{ V}$ to $6\text{ V}$ , $I_O = 0\text{ mA}$	0%	3%	
			$V_I = 2.5\text{ V}$ to $6\text{ V}$ , $0\text{ mA} \leq I_O \leq 400\text{ mA}$	-3%	3%	
	1.8 V	TPS62222	$V_I = 2.5\text{ V}$ to $6\text{ V}$ , $I_O = 0\text{ mA}$	0%	3%	
			$V_I = 2.5\text{ V}$ to $6\text{ V}$ , $0\text{ mA} \leq I_O \leq 400\text{ mA}$	-3%	3%	
	1.875 V	TPS62228	$V_I = 2.5\text{ V}$ to $6\text{ V}$ , $I_O = 0\text{ mA}$	0%	3%	
			$V_I = 2.5\text{ V}$ to $6\text{ V}$ , $0\text{ mA} \leq I_O \leq 400\text{ mA}$	-3%	3%	
	2.3 V	TPS62223	$V_I = 2.7\text{ V}$ to $6\text{ V}$ , $I_O = 0\text{ mA}$	0%	3%	
			$V_I = 2.7\text{ V}$ to $6\text{ V}$ , $0\text{ mA} \leq I_O \leq 400\text{ mA}$	-3%	3%	
	1.2 V	TPS62227	$V_I = 2.7\text{ V}$ to $6\text{ V}$ , $I_O = 0\text{ mA}$	0%	3%	
$V_I = 2.7\text{ V}$ to $6\text{ V}$ , $0\text{ mA} \leq I_O \leq 400\text{ mA}$			-3%	3%		
	Line regulation	$V_I = 2.5\text{ V}$ to $6\text{ V}$ , $I_O = 10\text{ mA}$		0.26		%/V
	Load regulation	$I_O = 100\text{ mA}$ to $400\text{ mA}$		0.0014		%/mA
$I_{lkg}$	Leakage current into SW pin	$V_I > V_O$ , $0\text{ V} \leq V_{(SW)} \leq V_I$		0.1	1	$\mu\text{A}$
	Reverse leakage current into pin SW	$V_I = \text{open}$ , $EN = GND$ , $V_{(SW)} = 6\text{ V}$		0.1	1	$\mu\text{A}$

(1) For output voltages  $\leq 1.2\text{ V}$ , a 22- $\mu\text{F}$  output capacitor value is required to achieve a maximum output voltage accuracy of 3% while operating in power-save mode (PFM mode). For output voltages  $\geq 2\text{ V}$ , an inductor of 10  $\mu\text{H}$  and an output capacitor of  $\geq 10\text{ }\mu\text{F}$  is recommended. See the *Application Information* section for external components.

## PIN ASSIGNMENTS

DDC PACKAGE  
(TOP VIEW)

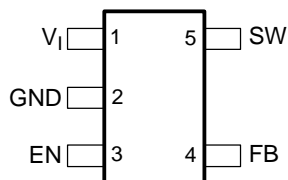

## Terminal Functions

TERMINAL		I/O	DESCRIPTION
NAME	NO.		
EN	3	I	This is the enable pin of the device. Pulling this pin to ground forces the device into shutdown mode. Pulling this pin to V <sub>in</sub> enables the device. This pin must be terminated.
FB	4	I	This is the feedback pin of the device. Connect this pin directly to the output if the fixed output voltage version is used. For the adjustable version, an external resistor divider is connected to this pin. The internal voltage divider is disabled for the adjustable version.
GND	2		Ground
SW	5	I/O	Connect the inductor to this pin. This pin is the switch pin and is connected to the internal MOSFET switches.
V <sub>I</sub>	1	I	Supply voltage pin

**FUNCTIONAL BLOCK DIAGRAM**

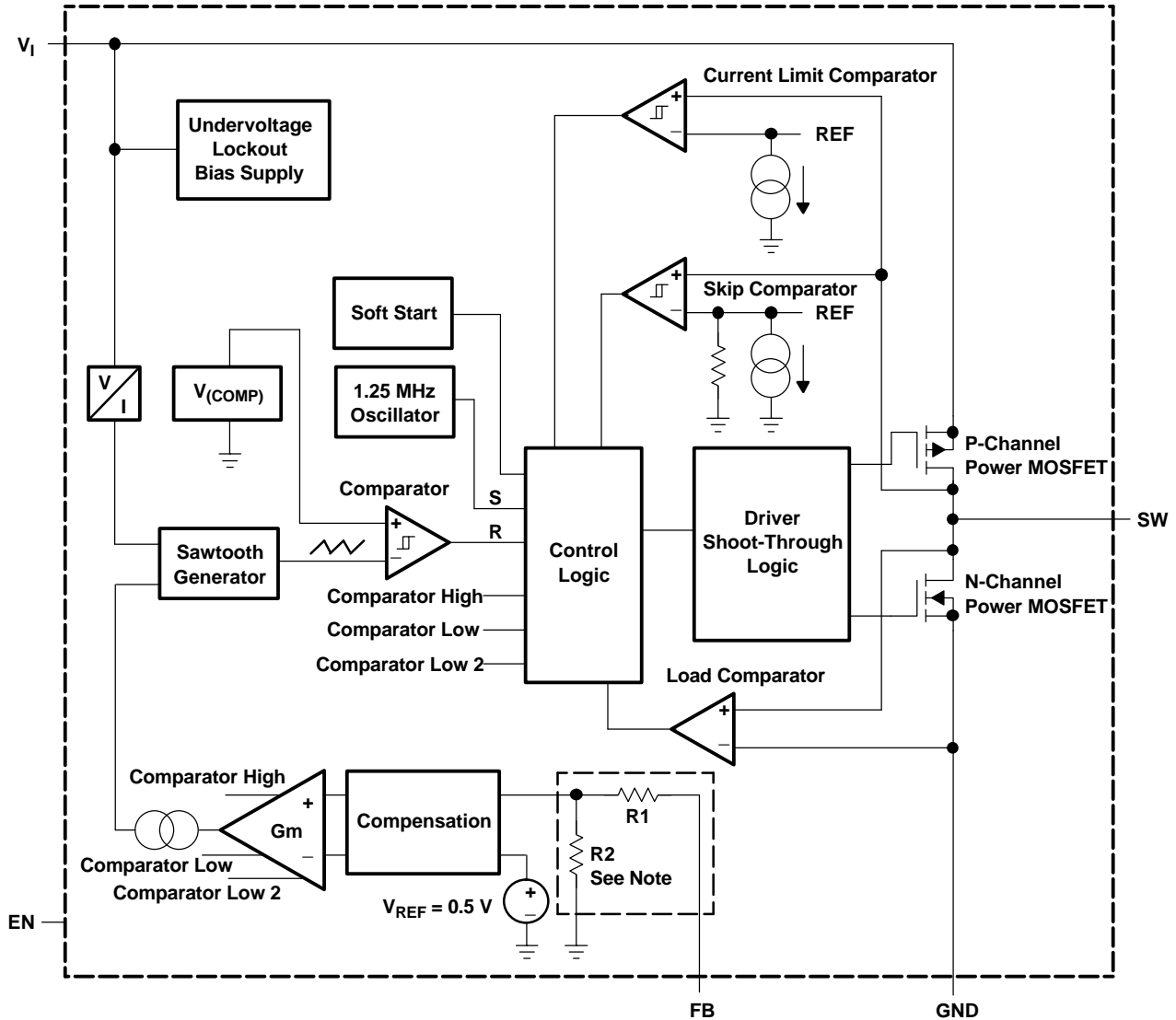

NOTE: For the adjustable version (TPS62220) the internal feedback divider is disabled, and the FB pin is directly connected to the internal GM amplifier

**TYPICAL CHARACTERISTICS**

**Table of Graphs**

			<b>FIGURE</b>
$\eta$	Efficiency	vs Load current	Figure 1, Figure 2, Figure 3
		vs Input voltage	Figure 4
$I_Q$	No load quiescent current	vs Input voltage	Figure 5
$f_s$	Switching frequency	vs Temperature	Figure 6
$V_o$	Output voltage	vs Output current	Figure 7
$r_{ds(on)}$	$r_{ds(on)}$ - P-channel switch,	vs Input voltage	Figure 8
	$r_{ds(on)}$ - N-Channel rectifier switch	vs Input voltage	Figure 9
	Load transient response		Figure 10
	PWM mode operation		Figure 11
	Power-save mode operation		Figure 12
	Start-up		Figure 13

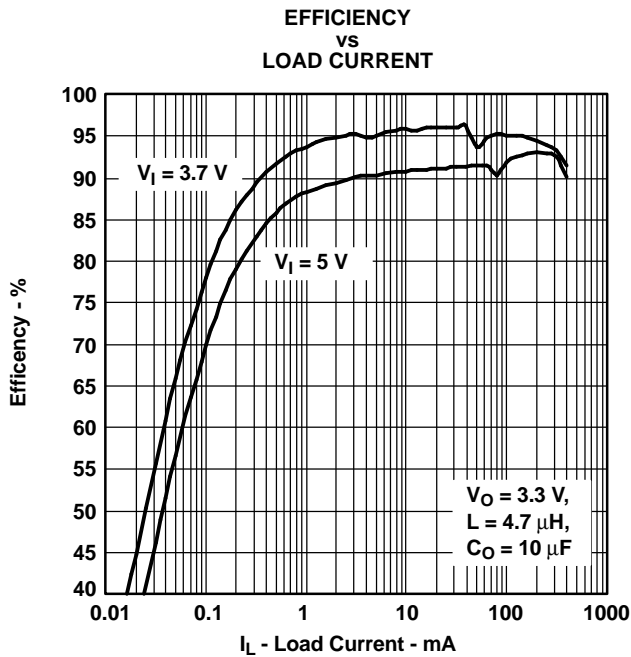

Figure 1.

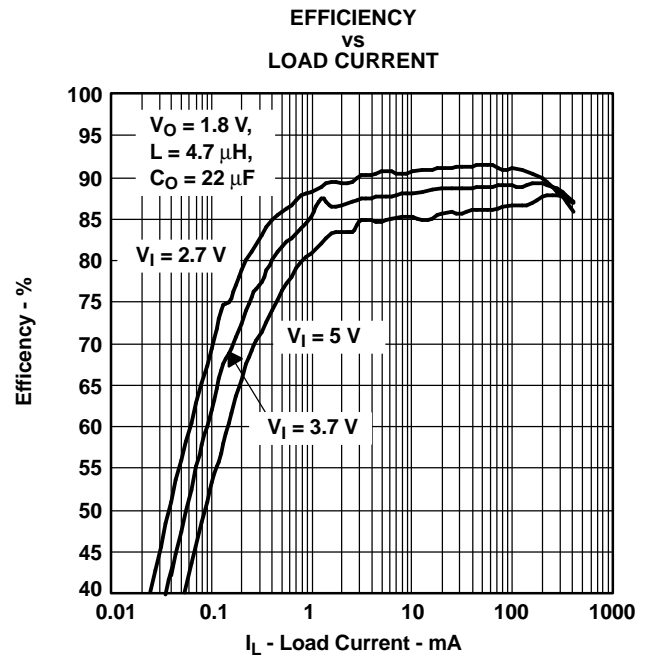

Figure 2.

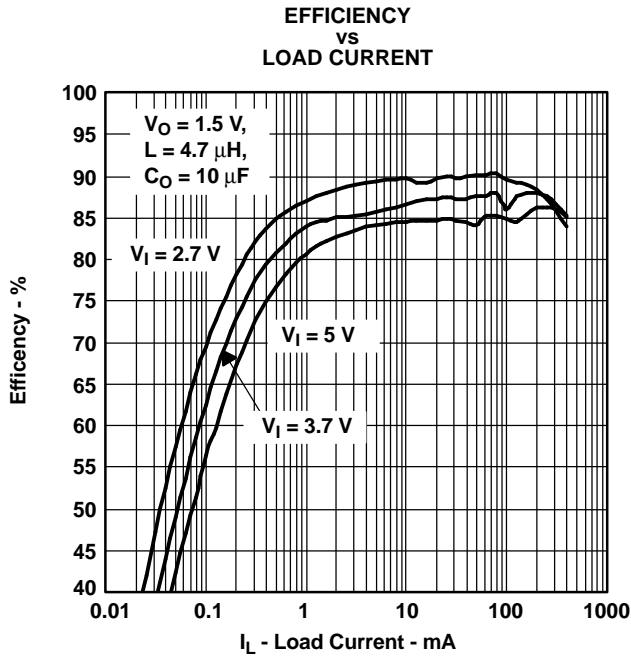

Figure 3.

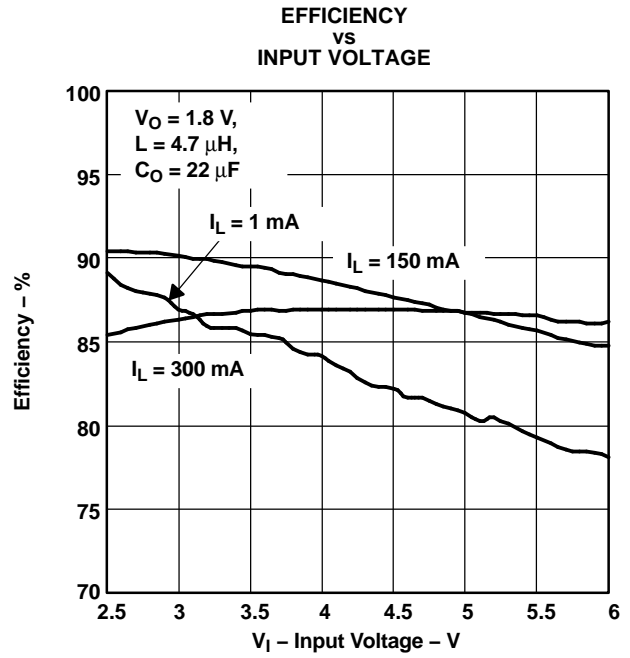

Figure 4.

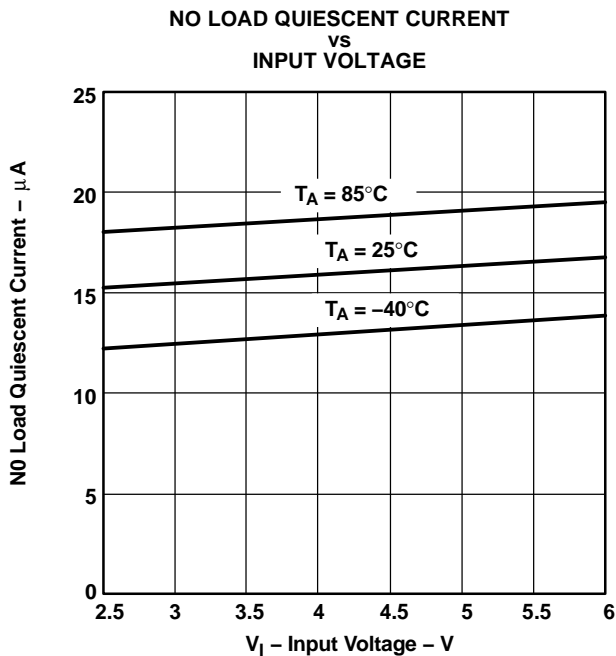

Figure 5.

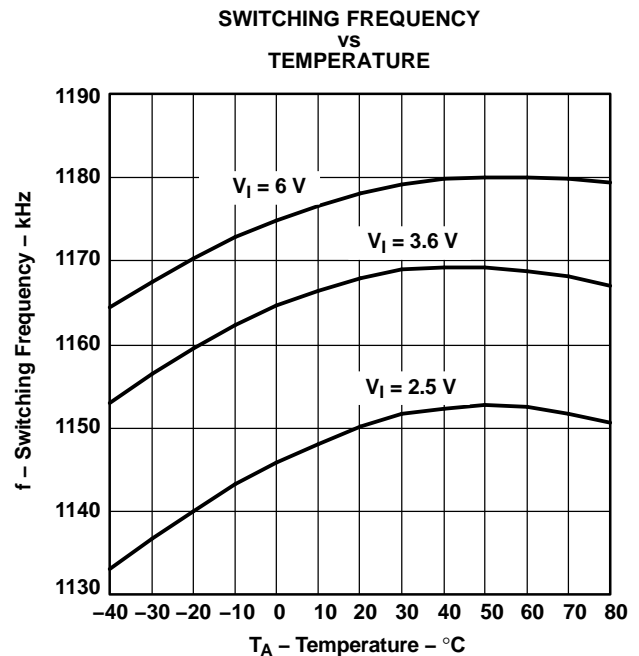

Figure 6.

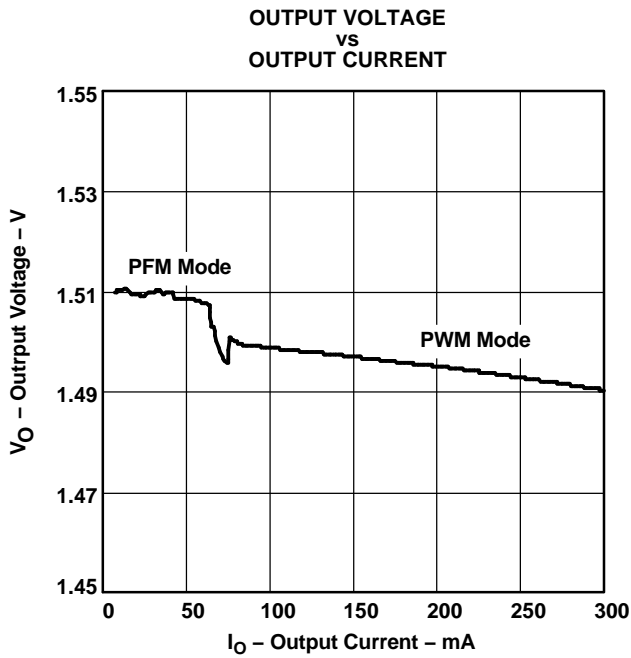

Figure 7.

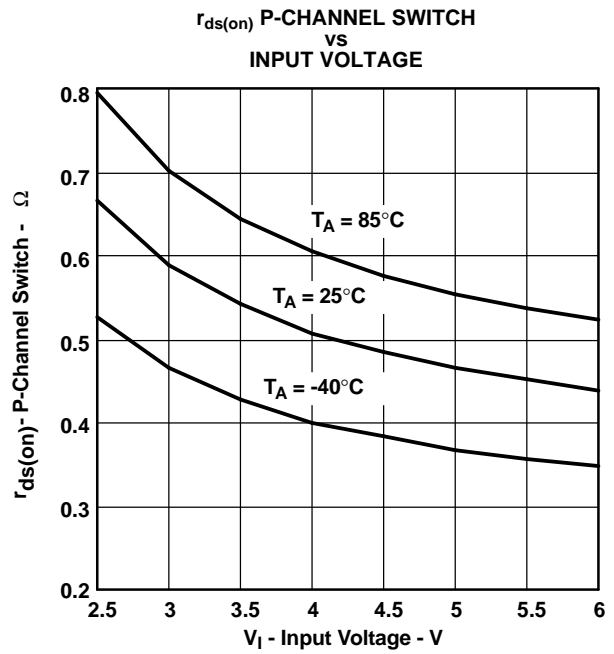

Figure 8.

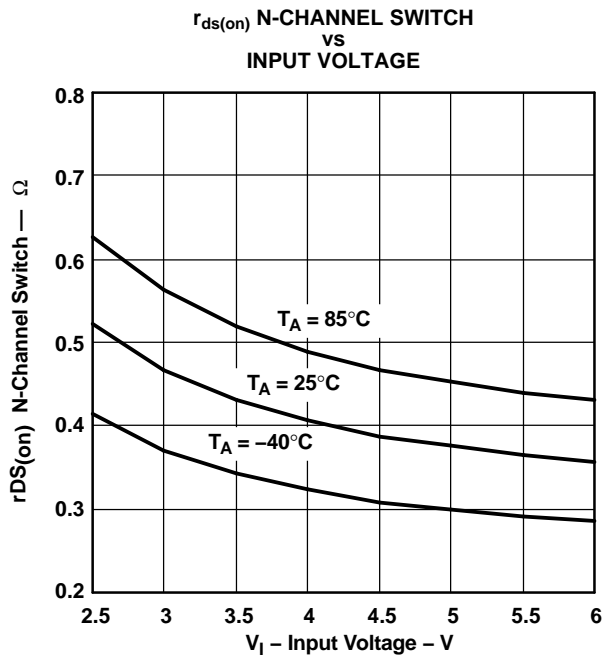

Figure 9.

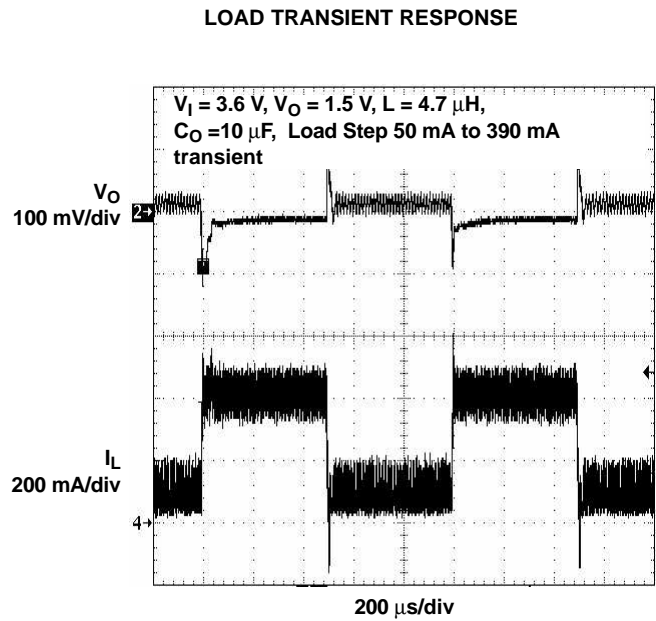

Figure 10.



**PWM MODE OPERATION**

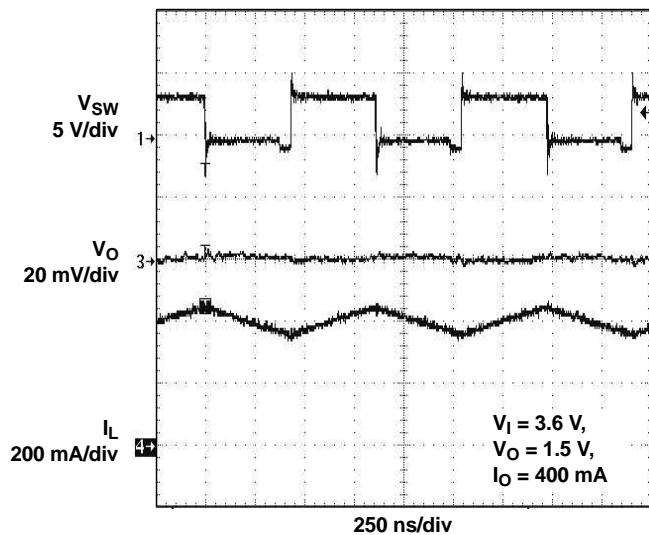

Figure 11.

**POWER-SAVE MODE OPERATION**

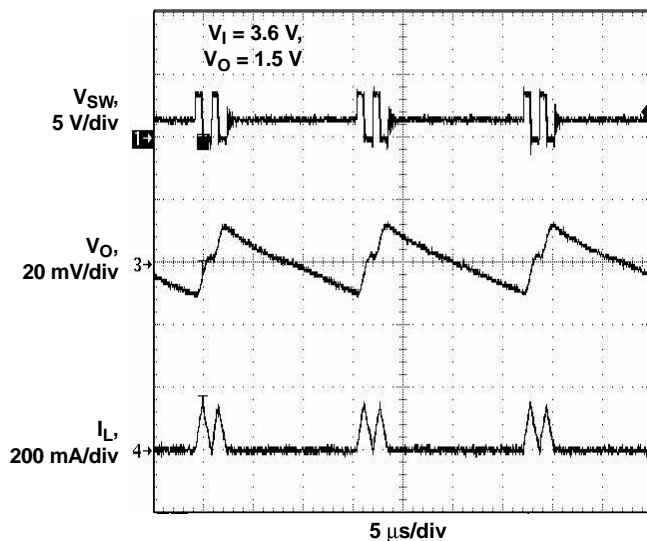

Figure 12.

**START-UP**

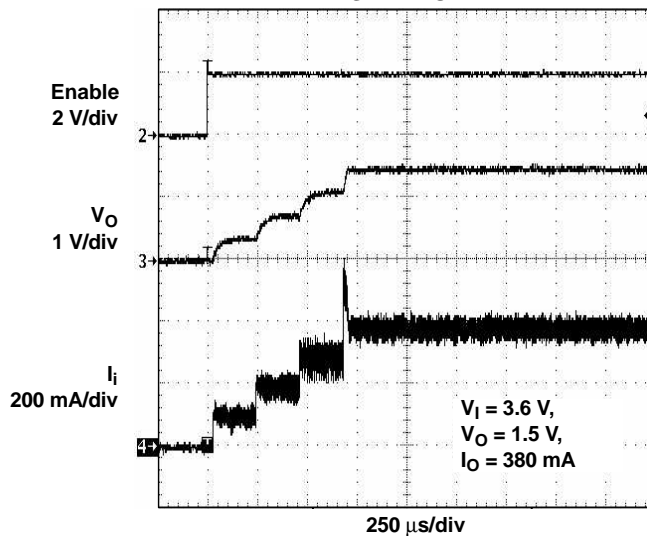

Figure 13.

## DETAILED DESCRIPTION

### OPERATION

The TPS6222x is a synchronous step-down converter operating with typically 1.25-MHz fixed frequency pulse width modulation (PWM) at moderate to heavy load currents and in power-save mode operating with pulse frequency modulation (PFM) at light load currents.

During PWM operation, the converter uses a unique fast response, voltage mode, controller scheme with input voltage feed forward. This achieves good line and load regulation and allows the use of small ceramic input and output capacitors. At the beginning of each clock cycle initiated by the clock signal (S), the P-channel MOSFET switch is turned on, and the inductor current ramps up until the comparator trips and the control logic turns off the switch. The current limit comparator also turns off the switch in case the current limit of the P-channel switch is exceeded. Then, the N-channel rectifier switch is turned on and the inductor current ramps down. The next cycle is initiated by the clock signal, again turning off the N-channel rectifier and turning on the P-channel switch.

The GM amplifier and input voltage determines the rise time of the sawtooth generator; therefore, any change in input voltage or output voltage directly controls the duty cycle of the converter. This gives a very good line and load transient regulation.

### POWER-SAVE MODE OPERATION

As the load current decreases, the converter enters the power-save mode operation. During power-save mode, the converter operates with reduced switching frequency in PFM mode and with a minimum quiescent current to maintain high efficiency. Two conditions allow the converter to enter the power-save mode operation. One is when the converter detects discontinuous conduction mode. The other is when the peak switch current in the P-channel switch goes below the skip current limit. The typical skip current limit can be calculated as:

$$I_{\text{skip}} \leq 66 \text{ mA} + \frac{V_{\text{in}}}{160 \Omega}$$

During the power-save mode, the output voltage is monitored with the comparator (comp) by the thresholds comp low and comp high. As the output voltage falls below the comp low threshold set to 0.8% typical above  $V_{\text{out}}$ , the P-channel switch turns on. The P-channel switch is turned off as the peak switch current is reached. The typical peak switch current can be calculated:

$$I_{\text{peak}} = 66 \text{ mA} + \frac{V_{\text{in}}}{80 \Omega}$$

The N-channel rectifier is turned on and the inductor current ramps down. As the inductor current approaches zero, the N-channel rectifier is turned off and the P-channel switch is turned on again, starting the next pulse. The converter continues these pulses until the comp high threshold (set to typically 1.6% above  $V_{\text{out}}$ ) is reached. The converter enters a sleep mode, reducing the quiescent current to a minimum. The converter wakes up again as the output voltage falls below the comp low threshold. This control method reduces the quiescent current typically to 15  $\mu\text{A}$  and reduces the switching frequency to a minimum, thereby achieving high converter efficiency at light load. Setting the skip current thresholds to typically 0.8% and 1.6% above the nominal output voltage at light load current results in a dynamic output voltage achieving lower absolute voltage drops during heavy load transient changes. This allows the converter to operate with a small output capacitor of just 10  $\mu\text{F}$  and still have a low absolute voltage drop during heavy load transient changes. See [Figure 14](#) for detailed operation of the power-save mode.

### DETAILED DESCRIPTION (continued)

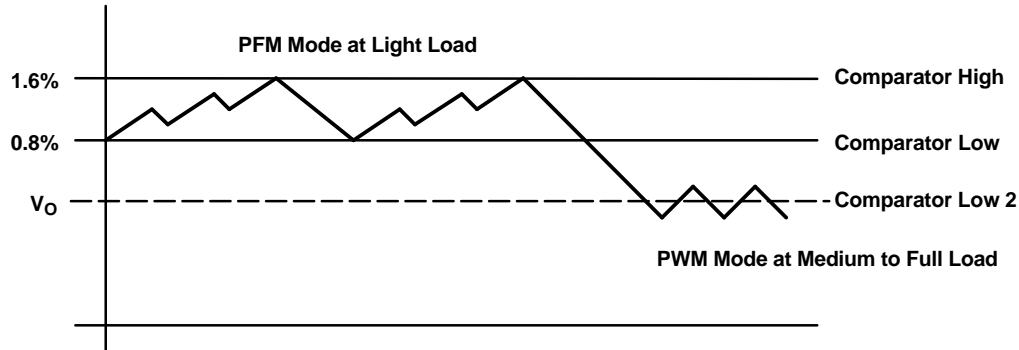

**Figure 14. Power-Save Mode Thresholds and Dynamic Voltage Positioning**

The converter enters the fixed frequency PWM mode again as soon as the output voltage falls below the comp low 2 threshold.

### DYNAMIC VOLTAGE POSITIONING

As described in the power-save mode operation sections and as detailed in [Figure 14](#), the output voltage is typically 0.8% above the nominal output voltage at light load currents, as the device is in power-save mode. This gives additional headroom for the voltage drop during a load transient from light load to full load. During a load transient from full load to light load, the voltage overshoot is also minimized due to active regulation by turning on the N-channel rectifier switch.

### DIGITAL SELF-CALIBRATION

In addition to the control circuit as shown in the block diagram, the TPS6222x series uses an internal digital self-calibration of the output voltage to minimize DC load and line regulation. This method of self-calibration allows simple internal loop compensation without the use of external components. The device monitors the output voltage and as soon as the output voltage drops below typically 1.6% or exceeds typically 1.6% of  $V_{out}$  the duty cycle will be adjusted in digital steps. As a result, the output voltage changes in digital steps either up or down where one step is typically 1% of  $V_{out}$ . This results in virtually zero line and load regulation and keeps the output voltage tolerance within  $\pm 3\%$  overload and line variations.

### SOFT START

The TPS6222x has an internal soft-start circuit that limits the inrush current during start-up. This prevents possible voltage drops of the input voltage in case a battery or a high impedance power source is connected to the input of the TPS6222x. The soft start is implemented as a digital circuit increasing the switch current in steps of typically 83 mA, 167 mA, 335 mA and then the typical switch current limit of 670 mA. Therefore, the start-up time mainly depends on the output capacitor and load current.

## DETAILED DESCRIPTION (continued)

### LOW DROPOUT OPERATION 100% DUTY CYCLE

The TPS6222x offers a low input to output voltage difference, while still maintaining operation with the 100% duty cycle mode. In this mode, the P-channel switch is constantly turned on. This is particularly useful in battery-powered applications to achieve longest operation time by taking full advantage of the whole battery voltage range. The minimum input voltage to maintain regulation, depending on the load current and output voltage, can be calculated as:

$$V_{Imin} = V_{Omax} + I_{Omax} \times (r_{DS(on)max} + R_L)$$

where:

- $I_{Omax}$  = maximum output current plus indicator ripple current
- $r_{DS(on)max}$  = maximum P-channel switch  $r_{DS(on)}$
- $R_L$  = dc resistance of the inductor
- $V_{Omax}$  = normal output voltage plus maximum output voltage tolerance

### ENABLE

Pulling the enable low forces the part into shutdown, with a shutdown quiescent current of typically 0.1  $\mu$ A. In this mode, the P-channel switch and N-channel rectifier are turned off, the internal resistor feedback divider is disconnected, and the whole device is in shutdown mode. If an output voltage, which could be an external voltage source or super capacitor, is present during shutdown, the reverse leakage current is specified under electrical characteristics. For proper operation, the enable pin must be terminated and must not be left floating.

Pulling the enable high starts up the TPS6222x with the soft start as previously described.

### UNDERVOLTAGE LOCKOUT

The undervoltage lockout circuit prevents the device from misoperation at low input voltages. It prevents the converter from turning on the switch or rectifier MOSFET under undefined conditions.

## APPLICATION INFORMATION

### OUTPUT FILTER DESIGN (INDUCTOR AND OUTPUT CAPACITOR)

The TPS6222x series of step-down converter has internal loop compensation. Therefore, the external L-C filter has to be selected to work with the internal compensation. This is especially important for the fixed output voltage version. The adjustable output voltage version allows external capacitors across the feedback divider resistors. This allows higher flexibility of the output filter selection when using the adjustable output voltage device TPS62220.

#### Fixed Output Voltage Version

The internal compensation is optimized to operate with an output filter of  $L = 10 \mu\text{H}$  and  $C_O = 10 \mu\text{F}$ . Such an output filter has its corner frequency at:

$$f_c = \frac{1}{2\pi \times \sqrt{L \times C_O}} = \frac{1}{2\pi \times \sqrt{10 \mu\text{H} \times 10 \mu\text{F}}} = 15.9 \text{ kHz}$$

with  $L = 10 \mu\text{H}$ ,  $C_O = 10 \mu\text{F}$

As a general rule of thumb, the product  $L \times C$  should not move over a wide range when selecting a different output filter. This is because the internal compensation is designed to work with a certain output filter corner frequency as calculated above. This is especially important when selecting smaller inductor or capacitor values that move the corner frequency to higher frequencies. However, when selecting the output filter a low limit for the inductor value exists due to other internal circuit limitations. For the TPS6222x series the minimum inductor value should be kept at  $4.7 \mu\text{H}$ . Selecting a larger output capacitor value is less critical because the corner frequency moves to lower frequencies causing fewer stability problems. The possible output filter combinations are listed in [Table 1](#):

**Table 1. Output Filter Combinations for Fixed Output Voltage Versions**

$V_O$	L	$C_O$
$\leq 2 \text{ V}$	$4.7 \mu\text{H}$	$\geq 22 \mu\text{F}$ (ceramic capacitor)
$\leq 2 \text{ V}$	$6.8 \mu\text{H}$	$\geq 22 \mu\text{F}$ (ceramic capacitor)
$\leq 2 \text{ V}$	$10 \mu\text{H}$	$\geq 10 \mu\text{F}$ (ceramic capacitor)
$\geq 2 \text{ V}$	$10 \mu\text{H}$	$10 \mu\text{F}$ (ceramic capacitor)

#### Adjustable Output Voltage Version

When the adjustable output voltage version TPS62220 is used, the output voltage is set by the external resistor divider. See [Figure 15](#).

The output voltage is calculated as

$$V_{\text{out}} = 0.5 \text{ V} \times \left( 1 + \frac{R_1}{R_2} \right)$$

with  $R_1 + R_2 \leq 1 \text{ M}\Omega$  and internal reference voltage  $V_{\text{ref,typ}} = 0.5 \text{ V}$

For stability,  $R_1 + R_2$  should not be greater than  $1 \text{ M}\Omega$ . To keep the operating quiescent current to a minimum, the feedback resistor divider should have high impedance with  $R_1 + R_2 \leq 1 \text{ M}\Omega$ . In general, for the adjustable output voltage version, the same stability considerations are valid as for the fixed output voltage version. Because the adjustable output voltage version uses an external feedback divider, it is possible to adjust the loop gain using external capacitors across the feedback resistors. This allows a wider selection of possible output filter components. This is shown in [Figure 16](#).  $R_1$  and  $C_1$  places a zero in the loop and  $R_2$  and  $C_2$  places a pole in the loop. The zero is calculated as:

$$C_1 = \frac{1}{2 \times \pi \times f_z \times R_1} = \frac{1}{2 \times \pi \times 22 \text{ kHz} \times R_1}$$

with  $R_1$  = upper resistor of voltage divider,  $C_1$  = upper capacitor of voltage divider

The pole is calculated as:

$$C2 = \frac{1}{2 \times \pi \times f_p \times R2} = \frac{1}{2 \times \pi \times 8 \text{ kHz} \times R2}$$

with R2 = lower resistor of voltage divider and C2 = lower capacitor of voltage divider.

For an output filter combination of L = 4.7 μH and C<sub>O</sub> = 10 μF, C1 and C2 must be selected to place a zero at 22 kHz, and a pole at 8 kHz. Choose components close to the calculated values.

**Table 2. Compensation Selection**

L	C <sub>O</sub>	f <sub>z</sub>	f <sub>p</sub>
4.7 μH	10 μF, 22 μF	22 kHz	8 kHz

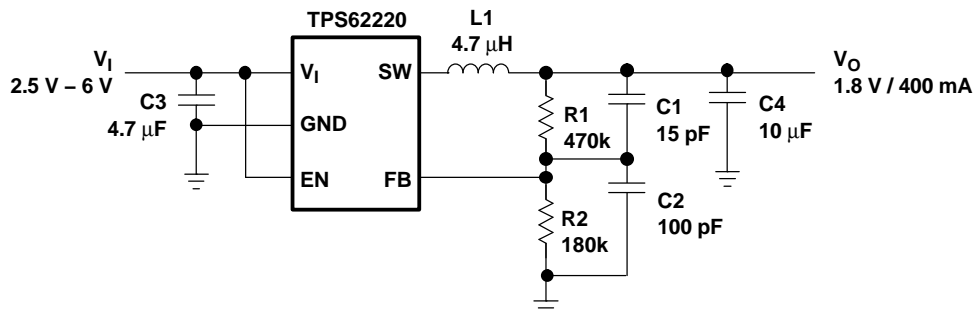

**Figure 15. Typical Application Circuit for the TPS62220 With Adjustable Output Voltage**

## INDUCTOR SELECTION

For high efficiencies, the inductor should have a low dc resistance to minimize conduction losses. Especially at high-switching frequencies the core material has a higher impact on efficiency. When using small chip inductors, the efficiency is reduced mainly due to higher inductor core losses. This needs to be considered when selecting the appropriate inductor. The inductor value determines the inductor ripple current. The larger the inductor value, the smaller the inductor ripple current and the lower the conduction losses of the converter. Conversely, larger inductor values cause a slower load transient response. To avoid saturation of the inductor, the inductor should be rated at least for the maximum output current of the converter plus the inductor ripple current that is calculated as:

$$I_L = V_O \times \frac{1 - \frac{V_O}{V_I}}{L \times f} \quad I_{L \text{ max}} = I_{O \text{ max}} + \frac{I_L}{2}$$

where:

- f = switching frequency (1.25-MHz typical, 800-kHz minimal)
- L = inductor value
- ΔI<sub>L</sub> = peak-to-peak inductor ripple current
- I<sub>L max</sub> = maximum inductor current

The highest inductor current occurs at maximum Vin. A more conservative approach is to select the inductor current rating just for the maximum switch current of 880 mA. See [Table 3](#) for inductor selection.

**Table 3. Inductor Selection**

INDUCTOR VALUE	COMPONENT SUPPLIER	DIMENSIONS
4.7 $\mu$ H	Sumida CDRH2D18/LD 4R7	3,2 mm $\times$ 3,2 mm $\times$ 2, 0 mm
4.7 $\mu$ H	Murata LQH3C4R7M24	3,2 mm $\times$ 2,5 mm $\times$ 2, 0 mm
4.7 $\mu$ H	Taiyo Yuden LBC2518 4R7	2,5 mm $\times$ 1,8 mm $\times$ 1,8 mm
4.7 $\mu$ H	Sumida CMD4D11 4R7	4,4 mm $\times$ 5,8 mm $\times$ 1,2 mm
4.7 $\mu$ H	Sumida CMD4D08 4R7	6,3 mm $\times$ 5,8 mm $\times$ 1, 0 mm
4.7 $\mu$ H	Sumida CLSD09 4R7	4,9 mm $\times$ 4,9 mm $\times$ 1, 0 mm
4.7 $\mu$ H	TDK VLF3010AT 4R7	2,8 mm $\times$ 2,6 mm $\times$ 1, 0 mm
6.8 $\mu$ H	Sumida CDRH3D16 6R8	4,0 mm $\times$ 4,0 mm $\times$ 1,8 mm
6.8 $\mu$ H	Sumida CMD4D11 4R7	4,0 mm $\times$ 5,8 mm $\times$ 1,2 mm
10 $\mu$ H	Murata LQH4C100K04	4,5 mm $\times$ 3,2 mm $\times$ 2, 6 mm
10 $\mu$ H	Sumida CDRH3D16 100	4,0 mm $\times$ 4,0 mm $\times$ 1,8 mm
10 $\mu$ H	Sumida CLS4D14 100	4,9 mm $\times$ 4,9 mm $\times$ 1,5 mm

## INPUT CAPACITOR SELECTION

Because buck converters have a pulsating input current, a low ESR input capacitor is required. This results in the best input voltage filtering, minimizing the interference with other circuits caused by high input voltage spikes. Also, the input capacitor must be sufficiently large to stabilize the input voltage during heavy load transients. For good input voltage filtering, usually a 4.7- $\mu$ F input capacitor is sufficient. It can be increased without any limit for better input-voltage filtering. Ceramic capacitors show better performance because of the low ESR value, and they are less sensitive against voltage transients and spikes compared to tantalum capacitors. Place the input capacitor as close as possible to the input and GND pin of the device for best performance (see [Table 4](#) for capacitor selection).

## OUTPUT CAPACITOR SELECTION

The advanced fast response voltage mode control scheme of the TPS6222x allows the use of tiny ceramic capacitors with a minimum value of 10  $\mu$ F without having large output voltage under and overshoots during heavy load transients. Ceramic capacitors with low ESR values have the lowest output voltage ripple and are recommended. If required, tantalum capacitors may be used as well (see [Table 4](#) for capacitor selection). At nominal load current, the device operates in power-save mode, and the output voltage ripple is independent of the output capacitor value. The output voltage ripple is set by the internal comparator thresholds. The typical output voltage ripple is 1% of the output voltage  $V_O$ .

**Table 4. Capacitor selection**

CAPACITOR VALUE	CASE SIZE	COMPONENT SUPPLIER
4.7 $\mu$ F	0603	Contact TDK
4.7 $\mu$ F	0805	Taiyo Yuden JMK212BY475MG
10 $\mu$ F	0805	Taiyo Yuden JMK212BJ106MG TDK C12012X5ROJ106K
22 $\mu$ F	0805 1206	Contact TDK Taiyo Yuden JMK316BJ226

## Layout Considerations

For all switching power supplies, the layout is an important step in the design, especially at high-peak currents and switching frequencies. If the layout is not carefully done, the regulator shows stability problems as well as EMI problems. Therefore, use wide and short traces for the main current paths, as indicated in bold in Figure 16. The input capacitor, as well as the inductor and output capacitor, should be placed as close as possible to the IC pins. In particular, the input capacitor needs to be placed as close as possible to the IC pins, directly across the  $V_{in}$  and GND pin. The feedback resistor network must be routed away from the inductor and switch node to minimize noise and magnetic interference. To further minimize noise from coupling into the feedback network and feedback pin, the ground plane or ground traces must be used for shielding. This becomes important especially at high switching frequencies of 1.25 MHz.

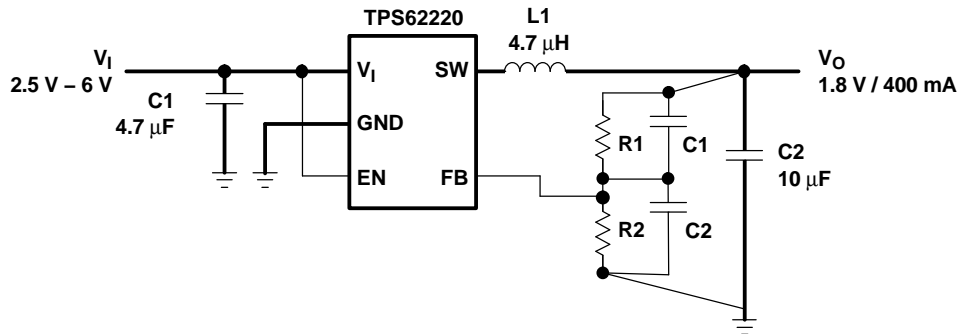

Figure 16. Layout Diagram

## Typical Applications

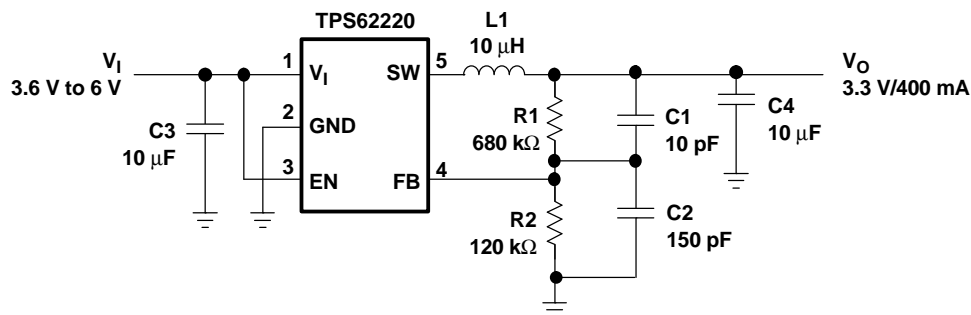

Figure 17. LI-Ion to 3.3-V Conversion

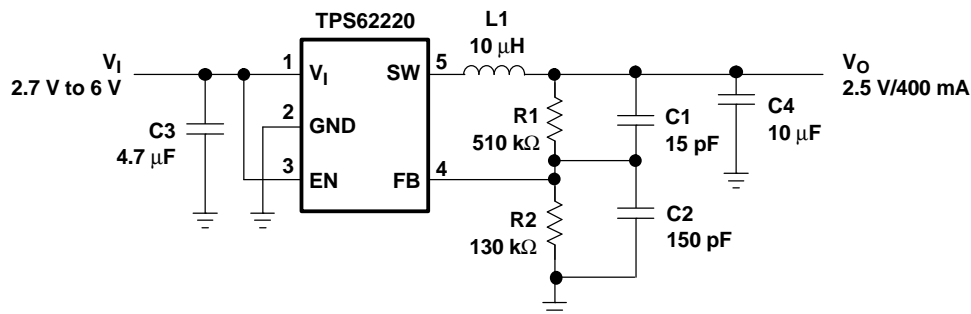

Figure 18. LI-Ion to 2.5-V Conversion



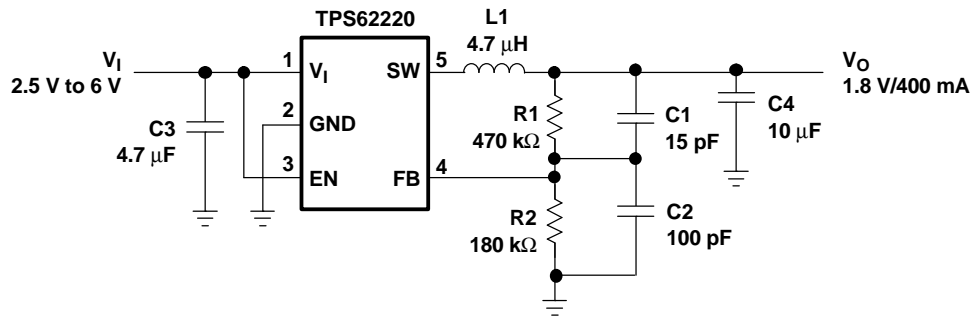

Figure 19. LI-Ion to 1.8-V Conversion

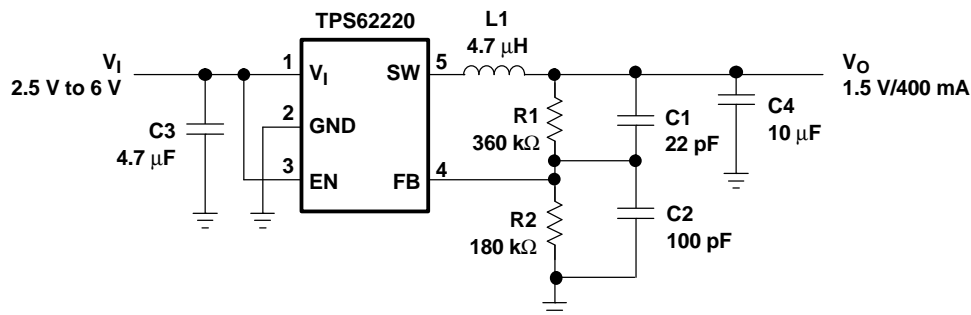

Figure 20. LI-Ion to 1.5-V Conversion

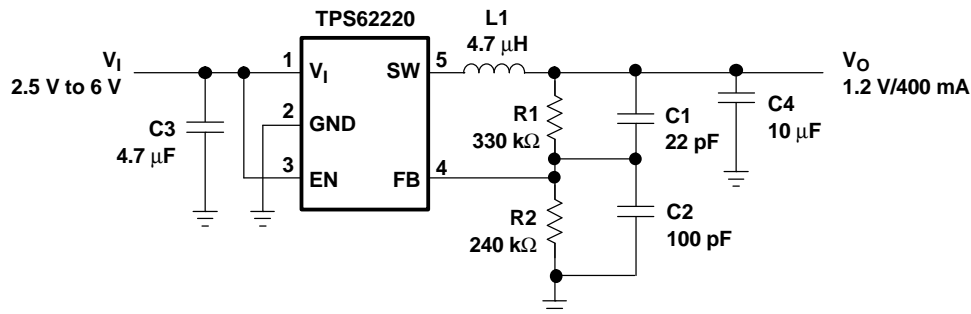

Figure 21. LI-Ion to 1.2-V Conversion

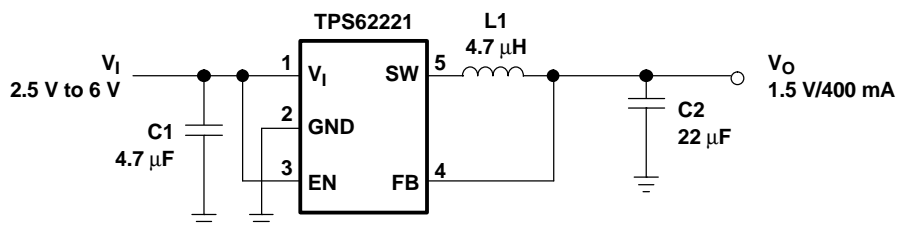

Figure 22. Li-Ion to 1.5-V Conversion, Fixed Output Voltage Version

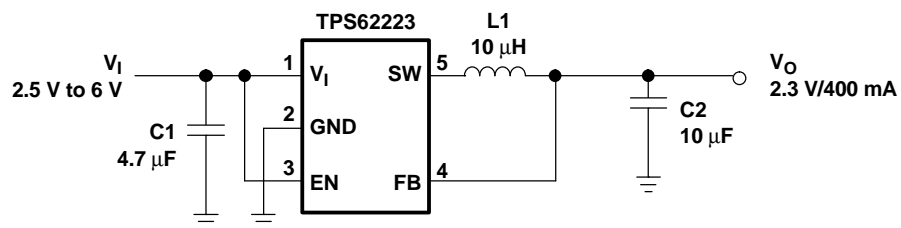

Figure 23. Li-Ion to 2.3-V Conversion, Fixed Output Voltage Version

**PACKAGING INFORMATION**

Orderable Device	Status <sup>(1)</sup>	Package Type	Package Drawing	Pins	Package Qty	Eco Plan <sup>(2)</sup>	Lead/Ball Finish	MSL Peak Temp <sup>(3)</sup>
TPS62220DDCR	ACTIVE	SOT	DDC	5	3000	Green (RoHS & no Sb/Br)	CU NIPDAU	Level-1-260C-UNLIM
TPS62220DDCRG4	ACTIVE	SOT	DDC	5	3000	Green (RoHS & no Sb/Br)	CU NIPDAU	Level-1-260C-UNLIM
TPS62220DDCT	ACTIVE	SOT	DDC	5	250	Green (RoHS & no Sb/Br)	CU NIPDAU	Level-1-260C-UNLIM
TPS62220DDCTG4	ACTIVE	SOT	DDC	5	250	Green (RoHS & no Sb/Br)	CU NIPDAU	Level-1-260C-UNLIM
TPS62221DDCR	ACTIVE	SOT	DDC	5	3000	Green (RoHS & no Sb/Br)	CU NIPDAU	Level-1-260C-UNLIM
TPS62221DDCRG4	ACTIVE	SOT	DDC	5	3000	Green (RoHS & no Sb/Br)	CU NIPDAU	Level-1-260C-UNLIM
TPS62221DDCT	ACTIVE	SOT	DDC	5	250	Green (RoHS & no Sb/Br)	CU NIPDAU	Level-1-260C-UNLIM
TPS62221DDCTG4	ACTIVE	SOT	DDC	5	250	Green (RoHS & no Sb/Br)	CU NIPDAU	Level-1-260C-UNLIM
TPS62222DDCR	ACTIVE	SOT	DDC	5	3000	Green (RoHS & no Sb/Br)	CU NIPDAU	Level-1-260C-UNLIM
TPS62222DDCRG4	ACTIVE	SOT	DDC	5	3000	Green (RoHS & no Sb/Br)	CU NIPDAU	Level-1-260C-UNLIM
TPS62222DDCT	ACTIVE	SOT	DDC	5	250	Green (RoHS & no Sb/Br)	CU NIPDAU	Level-1-260C-UNLIM
TPS62222DDCTG4	ACTIVE	SOT	DDC	5	250	Green (RoHS & no Sb/Br)	CU NIPDAU	Level-1-260C-UNLIM
TPS62223DDCR	ACTIVE	SOT	DDC	5	3000	Green (RoHS & no Sb/Br)	CU NIPDAU	Level-1-260C-UNLIM
TPS62223DDCRG4	ACTIVE	SOT	DDC	5	3000	Green (RoHS & no Sb/Br)	CU NIPDAU	Level-1-260C-UNLIM
TPS62223DDCT	ACTIVE	SOT	DDC	5	250	Green (RoHS & no Sb/Br)	CU NIPDAU	Level-1-260C-UNLIM
TPS62223DDCTG4	ACTIVE	SOT	DDC	5	250	Green (RoHS & no Sb/Br)	CU NIPDAU	Level-1-260C-UNLIM
TPS62224DDCR	ACTIVE	SOT	DDC	5	3000	Green (RoHS & no Sb/Br)	CU NIPDAU	Level-1-260C-UNLIM
TPS62224DDCRG4	ACTIVE	SOT	DDC	5	3000	Green (RoHS & no Sb/Br)	CU NIPDAU	Level-1-260C-UNLIM
TPS62224DDCT	ACTIVE	SOT	DDC	5	250	Green (RoHS & no Sb/Br)	CU NIPDAU	Level-1-260C-UNLIM
TPS62224DDCTG4	ACTIVE	SOT	DDC	5	250	Green (RoHS & no Sb/Br)	CU NIPDAU	Level-1-260C-UNLIM
TPS62227DDCR	ACTIVE	SOT	DDC	5	3000	Green (RoHS & no Sb/Br)	CU NIPDAU	Level-1-260C-UNLIM
TPS62227DDCRG4	ACTIVE	SOT	DDC	5	3000	Green (RoHS & no Sb/Br)	CU NIPDAU	Level-1-260C-UNLIM
TPS62227DDCT	ACTIVE	SOT	DDC	5	250	Green (RoHS & no Sb/Br)	CU NIPDAU	Level-1-260C-UNLIM
TPS62227DDCTG4	ACTIVE	SOT	DDC	5	250	Green (RoHS & no Sb/Br)	CU NIPDAU	Level-1-260C-UNLIM
TPS62228DDCR	ACTIVE	SOT	DDC	5	3000	Green (RoHS & no Sb/Br)	CU NIPDAU	Level-1-260C-UNLIM

Orderable Device	Status <sup>(1)</sup>	Package Type	Package Drawing	Pins	Package Qty	Eco Plan <sup>(2)</sup>	Lead/Ball Finish	MSL Peak Temp <sup>(3)</sup>
TPS62228DDCRG4	ACTIVE	SOT	DDC	5	3000	Green (RoHS & no Sb/Br)	CU NIPDAU	Level-1-260C-UNLIM
TPS62228DDCT	ACTIVE	SOT	DDC	5	250	Green (RoHS & no Sb/Br)	CU NIPDAU	Level-1-260C-UNLIM
TPS62228DDCTG4	ACTIVE	SOT	DDC	5	250	Green (RoHS & no Sb/Br)	CU NIPDAU	Level-1-260C-UNLIM
TPS62229DDCR	ACTIVE	SOT	DDC	5	3000	Green (RoHS & no Sb/Br)	CU NIPDAU	Level-1-260C-UNLIM
TPS62229DDCRG4	ACTIVE	SOT	DDC	5	3000	Green (RoHS & no Sb/Br)	CU NIPDAU	Level-1-260C-UNLIM
TPS62229DDCT	ACTIVE	SOT	DDC	5	250	Green (RoHS & no Sb/Br)	CU NIPDAU	Level-1-260C-UNLIM
TPS62229DDCTG4	ACTIVE	SOT	DDC	5	250	Green (RoHS & no Sb/Br)	CU NIPDAU	Level-1-260C-UNLIM

<sup>(1)</sup> The marketing status values are defined as follows:

**ACTIVE:** Product device recommended for new designs.

**LIFEBUY:** TI has announced that the device will be discontinued, and a lifetime-buy period is in effect.

**NRND:** Not recommended for new designs. Device is in production to support existing customers, but TI does not recommend using this part in a new design.

**PREVIEW:** Device has been announced but is not in production. Samples may or may not be available.

**OBSOLETE:** TI has discontinued the production of the device.

<sup>(2)</sup> Eco Plan - The planned eco-friendly classification: Pb-Free (RoHS), Pb-Free (RoHS Exempt), or Green (RoHS & no Sb/Br) - please check <http://www.ti.com/productcontent> for the latest availability information and additional product content details.

**TBD:** The Pb-Free/Green conversion plan has not been defined.

**Pb-Free (RoHS):** TI's terms "Lead-Free" or "Pb-Free" mean semiconductor products that are compatible with the current RoHS requirements for all 6 substances, including the requirement that lead not exceed 0.1% by weight in homogeneous materials. Where designed to be soldered at high temperatures, TI Pb-Free products are suitable for use in specified lead-free processes.

**Pb-Free (RoHS Exempt):** This component has a RoHS exemption for either 1) lead-based flip-chip solder bumps used between the die and package, or 2) lead-based die adhesive used between the die and leadframe. The component is otherwise considered Pb-Free (RoHS compatible) as defined above.

**Green (RoHS & no Sb/Br):** TI defines "Green" to mean Pb-Free (RoHS compatible), and free of Bromine (Br) and Antimony (Sb) based flame retardants (Br or Sb do not exceed 0.1% by weight in homogeneous material)

<sup>(3)</sup> MSL, Peak Temp. -- The Moisture Sensitivity Level rating according to the JEDEC industry standard classifications, and peak solder temperature.

**Important Information and Disclaimer:** The information provided on this page represents TI's knowledge and belief as of the date that it is provided. TI bases its knowledge and belief on information provided by third parties, and makes no representation or warranty as to the accuracy of such information. Efforts are underway to better integrate information from third parties. TI has taken and continues to take reasonable steps to provide representative and accurate information but may not have conducted destructive testing or chemical analysis on incoming materials and chemicals. TI and TI suppliers consider certain information to be proprietary, and thus CAS numbers and other limited information may not be available for release.

In no event shall TI's liability arising out of such information exceed the total purchase price of the TI part(s) at issue in this document sold by TI to Customer on an annual basis.

**TAPE AND REEL BOX INFORMATION**

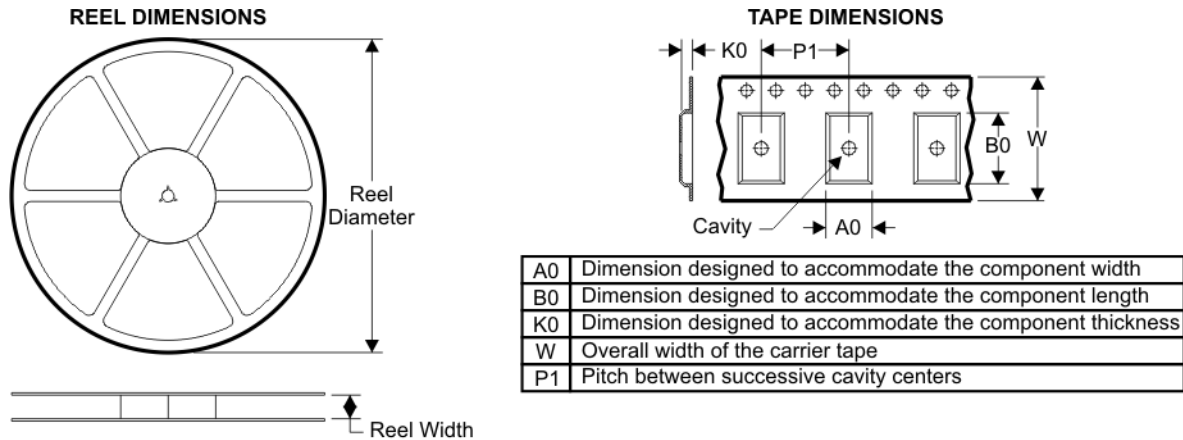

**QUADRANT ASSIGNMENTS FOR PIN 1 ORIENTATION IN TAPE**

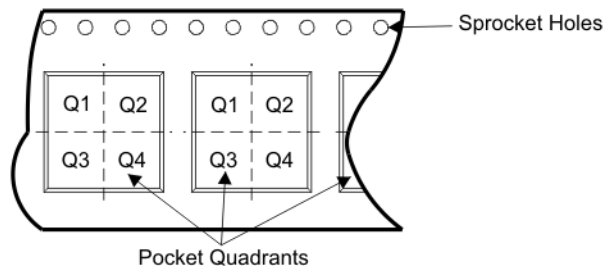

Device	Package	Pins	Site	Reel Diameter (mm)	Reel Width (mm)	A0 (mm)	B0 (mm)	K0 (mm)	P1 (mm)	W (mm)	Pin1 Quadrant
TPS62220DDCR	DDC	5	SITE 35	180	9	3.1	3.05	1.1	4	8	Q3
TPS62220DDCT	DDC	5	SITE 35	180	9	3.1	3.05	1.1	4	8	Q3
TPS62221DDCR	DDC	5	SITE 35	180	9	3.1	3.05	1.1	4	8	Q3
TPS62221DDCT	DDC	5	SITE 35	180	9	3.1	3.05	1.1	4	8	Q3
TPS62222DDCR	DDC	5	SITE 35	180	9	3.1	3.05	1.1	4	8	Q3
TPS62222DDCT	DDC	5	SITE 35	180	9	3.1	3.05	1.1	4	8	Q3
TPS62223DDCR	DDC	5	SITE 35	180	9	3.1	3.05	1.1	4	8	Q3
TPS62223DDCT	DDC	5	SITE 35	180	9	3.1	3.05	1.1	4	8	Q3
TPS62224DDCR	DDC	5	SITE 35	180	9	3.1	3.05	1.1	4	8	Q3
TPS62224DDCT	DDC	5	SITE 35	180	9	3.1	3.05	1.1	4	8	Q3
TPS62227DDCR	DDC	5	SITE 35	180	9	3.1	3.05	1.1	4	8	Q3
TPS62227DDCT	DDC	5	SITE 35	180	9	3.1	3.05	1.1	4	8	Q3
TPS62228DDCR	DDC	5	SITE 35	180	9	3.1	3.05	1.1	4	8	Q3
TPS62228DDCT	DDC	5	SITE 35	180	9	3.1	3.05	1.1	4	8	Q3
TPS62229DDCR	DDC	5	SITE 35	180	9	3.1	3.05	1.1	4	8	Q3
TPS62229DDCT	DDC	5	SITE 35	180	9	3.1	3.05	1.1	4	8	Q3

## TAPE AND REEL BOX DIMENSIONS

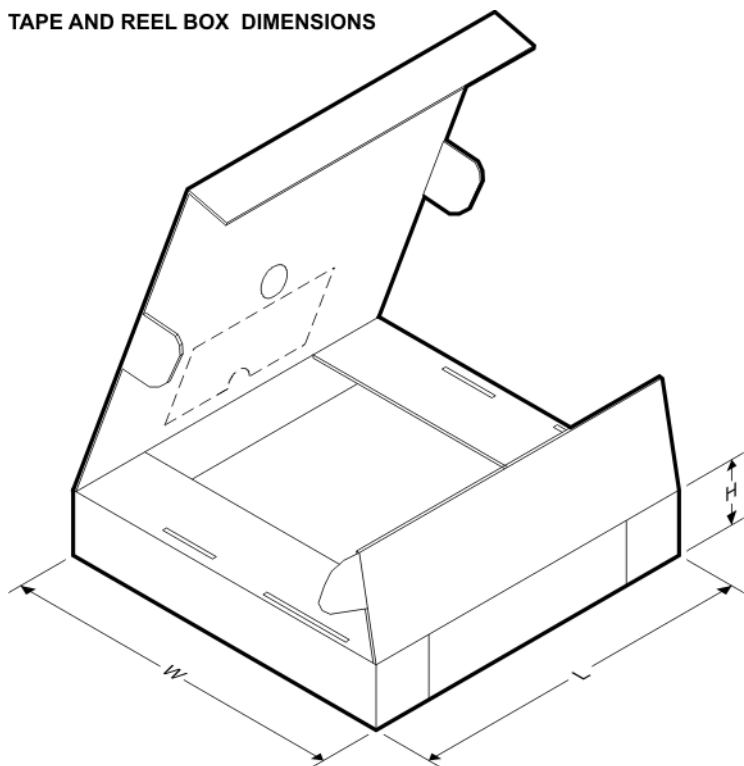

Device	Package	Pins	Site	Length (mm)	Width (mm)	Height (mm)
TPS62220DDCR	DDC	5	SITE 35	180.0	180.0	85.0
TPS62220DDCT	DDC	5	SITE 35	180.0	180.0	85.0
TPS62221DDCR	DDC	5	SITE 35	180.0	180.0	85.0
TPS62221DDCT	DDC	5	SITE 35	180.0	180.0	85.0
TPS62222DDCR	DDC	5	SITE 35	180.0	180.0	85.0
TPS62222DDCT	DDC	5	SITE 35	180.0	180.0	85.0
TPS62223DDCR	DDC	5	SITE 35	180.0	180.0	85.0
TPS62223DDCT	DDC	5	SITE 35	180.0	180.0	85.0
TPS62224DDCR	DDC	5	SITE 35	180.0	180.0	85.0
TPS62224DDCT	DDC	5	SITE 35	180.0	180.0	85.0
TPS62227DDCR	DDC	5	SITE 35	180.0	180.0	85.0
TPS62227DDCT	DDC	5	SITE 35	180.0	180.0	85.0
TPS62228DDCR	DDC	5	SITE 35	180.0	180.0	85.0
TPS62228DDCT	DDC	5	SITE 35	180.0	180.0	85.0
TPS62229DDCR	DDC	5	SITE 35	180.0	180.0	85.0
TPS62229DDCT	DDC	5	SITE 35	180.0	180.0	85.0

# MECHANICAL DATA

DDC (R-PDSO-G5)

PLASTIC SMALL-OUTLINE

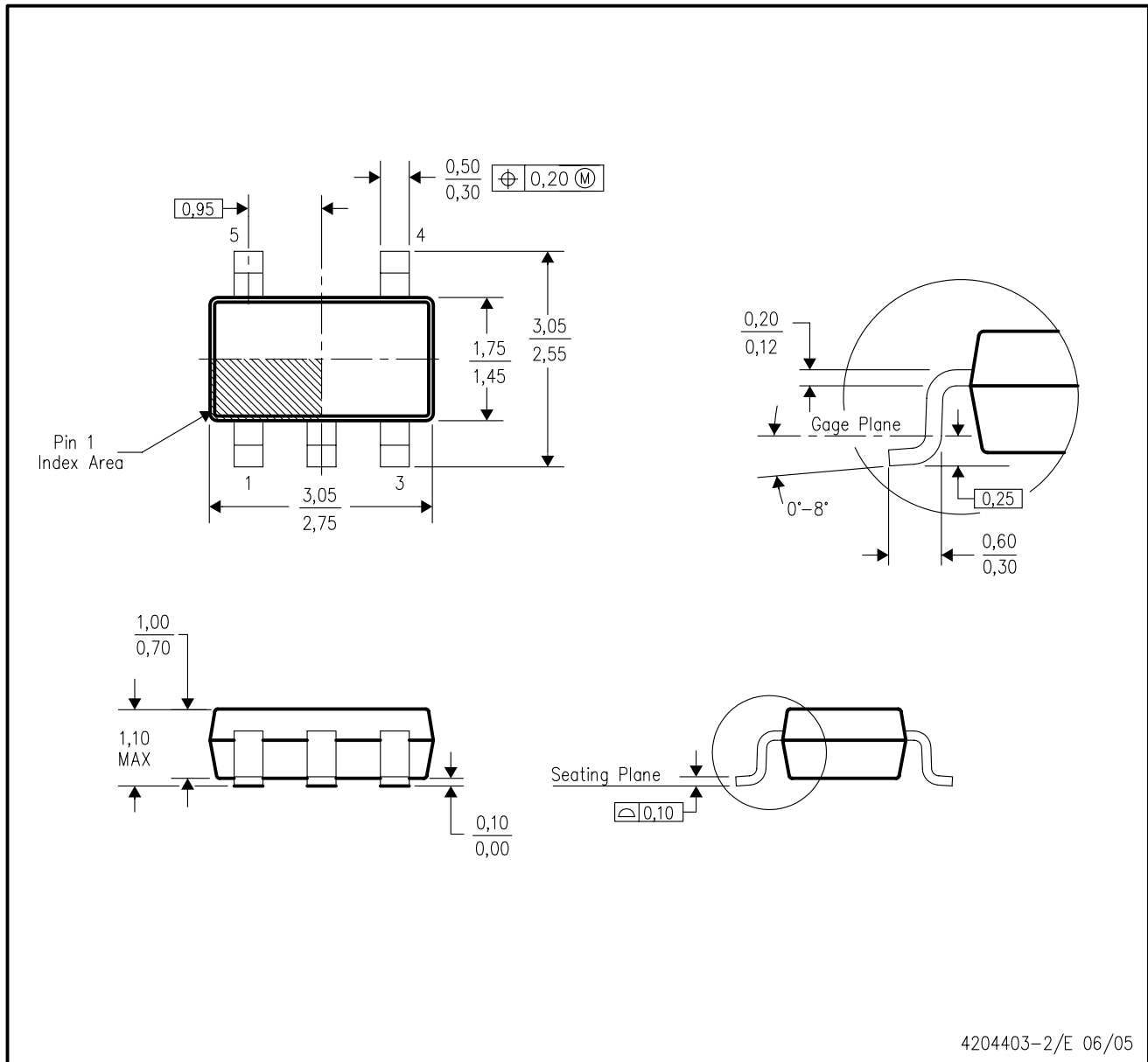

4204403-2/E 06/05

- NOTES:
- All linear dimensions are in millimeters.
  - This drawing is subject to change without notice.
  - Body dimensions do not include mold flash or protrusion.
  - Falls within JEDEC MO-193 variation AB (5 pin).

## IMPORTANT NOTICE

Texas Instruments Incorporated and its subsidiaries (TI) reserve the right to make corrections, modifications, enhancements, improvements, and other changes to its products and services at any time and to discontinue any product or service without notice. Customers should obtain the latest relevant information before placing orders and should verify that such information is current and complete. All products are sold subject to TI's terms and conditions of sale supplied at the time of order acknowledgment.

TI warrants performance of its hardware products to the specifications applicable at the time of sale in accordance with TI's standard warranty. Testing and other quality control techniques are used to the extent TI deems necessary to support this warranty. Except where mandated by government requirements, testing of all parameters of each product is not necessarily performed.

TI assumes no liability for applications assistance or customer product design. Customers are responsible for their products and applications using TI components. To minimize the risks associated with customer products and applications, customers should provide adequate design and operating safeguards.

TI does not warrant or represent that any license, either express or implied, is granted under any TI patent right, copyright, mask work right, or other TI intellectual property right relating to any combination, machine, or process in which TI products or services are used. Information published by TI regarding third-party products or services does not constitute a license from TI to use such products or services or a warranty or endorsement thereof. Use of such information may require a license from a third party under the patents or other intellectual property of the third party, or a license from TI under the patents or other intellectual property of TI.

Reproduction of TI information in TI data books or data sheets is permissible only if reproduction is without alteration and is accompanied by all associated warranties, conditions, limitations, and notices. Reproduction of this information with alteration is an unfair and deceptive business practice. TI is not responsible or liable for such altered documentation. Information of third parties may be subject to additional restrictions.

Resale of TI products or services with statements different from or beyond the parameters stated by TI for that product or service voids all express and any implied warranties for the associated TI product or service and is an unfair and deceptive business practice. TI is not responsible or liable for any such statements.

TI products are not authorized for use in safety-critical applications (such as life support) where a failure of the TI product would reasonably be expected to cause severe personal injury or death, unless officers of the parties have executed an agreement specifically governing such use. Buyers represent that they have all necessary expertise in the safety and regulatory ramifications of their applications, and acknowledge and agree that they are solely responsible for all legal, regulatory and safety-related requirements concerning their products and any use of TI products in such safety-critical applications, notwithstanding any applications-related information or support that may be provided by TI. Further, Buyers must fully indemnify TI and its representatives against any damages arising out of the use of TI products in such safety-critical applications.

TI products are neither designed nor intended for use in military/aerospace applications or environments unless the TI products are specifically designated by TI as military-grade or "enhanced plastic." Only products designated by TI as military-grade meet military specifications. Buyers acknowledge and agree that any such use of TI products which TI has not designated as military-grade is solely at the Buyer's risk, and that they are solely responsible for compliance with all legal and regulatory requirements in connection with such use.

TI products are neither designed nor intended for use in automotive applications or environments unless the specific TI products are designated by TI as compliant with ISO/TS 16949 requirements. Buyers acknowledge and agree that, if they use any non-designated products in automotive applications, TI will not be responsible for any failure to meet such requirements.

Following are URLs where you can obtain information on other Texas Instruments products and application solutions:

<b>Products</b>		<b>Applications</b>	
Amplifiers	<a href="http://amplifier.ti.com">amplifier.ti.com</a>	Audio	<a href="http://www.ti.com/audio">www.ti.com/audio</a>
Data Converters	<a href="http://dataconverter.ti.com">dataconverter.ti.com</a>	Automotive	<a href="http://www.ti.com/automotive">www.ti.com/automotive</a>
DSP	<a href="http://dsp.ti.com">dsp.ti.com</a>	Broadband	<a href="http://www.ti.com/broadband">www.ti.com/broadband</a>
Interface	<a href="http://interface.ti.com">interface.ti.com</a>	Digital Control	<a href="http://www.ti.com/digitalcontrol">www.ti.com/digitalcontrol</a>
Logic	<a href="http://logic.ti.com">logic.ti.com</a>	Military	<a href="http://www.ti.com/military">www.ti.com/military</a>
Power Mgmt	<a href="http://power.ti.com">power.ti.com</a>	Optical Networking	<a href="http://www.ti.com/opticalnetwork">www.ti.com/opticalnetwork</a>
Microcontrollers	<a href="http://microcontroller.ti.com">microcontroller.ti.com</a>	Security	<a href="http://www.ti.com/security">www.ti.com/security</a>
RFID	<a href="http://www.ti-rfid.com">www.ti-rfid.com</a>	Telephony	<a href="http://www.ti.com/telephony">www.ti.com/telephony</a>
Low Power Wireless	<a href="http://www.ti.com/lpw">www.ti.com/lpw</a>	Video & Imaging	<a href="http://www.ti.com/video">www.ti.com/video</a>
		Wireless	<a href="http://www.ti.com/wireless">www.ti.com/wireless</a>