



Integrated
Circuit
Systems, Inc.

ICS84329B

700MHz, Low JITTER, CRYSTAL-TO-3.3V DIFFERENTIAL LVPECL FREQUENCY SYNTHESIZER

GENERAL DESCRIPTION



The ICS84329B is a general purpose, single output high frequency synthesizer and a member of the HiPerClockS™ family of High Performance Clock Solutions from ICS. The VCO operates at a frequency range of 250MHz to 700MHz. The VCO frequency is programmed in steps equal to the value of the crystal frequency divided by 16. The VCO and output frequency can be programmed using the serial or parallel interfaces to the configuration logic. The output can be configured to divide the VCO frequency by 1, 2, 4, and 8. Output frequency steps as small as 125kHz to 1MHz can be achieved using a 16MHz crystal depending on the output dividers.

FEATURES

- Fully integrated PLL, no external loop filter requirements
- One differential 3.3V LVPECL output
- Parallel resonant crystal oscillator interface
- Output frequency range: 31.25MHz to 700MHz
- VCO range: 250MHz to 700MHz
- Parallel interface for programming counter and output dividers during power-up
- Serial 3 wire interface
- RMS Period jitter: 5.5ps (maximum)
- Cycle-to-cycle jitter: 35ps (maximum)
- 3.3V supply voltage
- 0°C to 70°C ambient operating temperature
- Available in both standard and lead-free RoHS compliant packages

BLOCK DIAGRAM

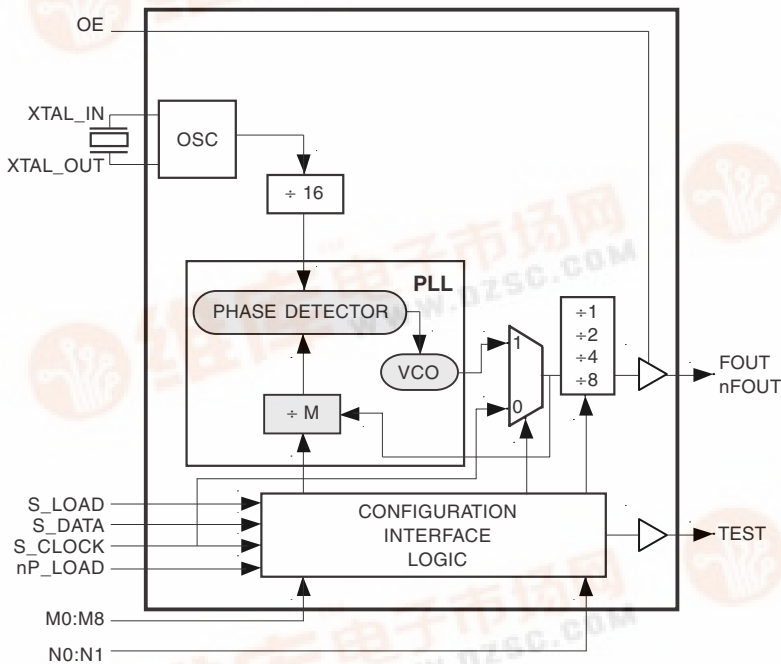

PIN ASSIGNMENT

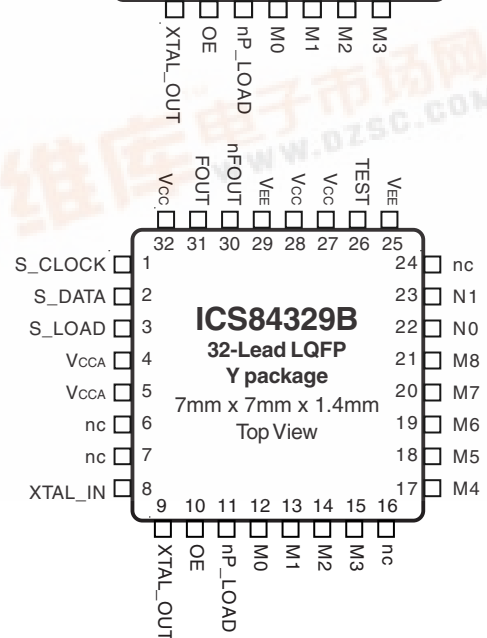
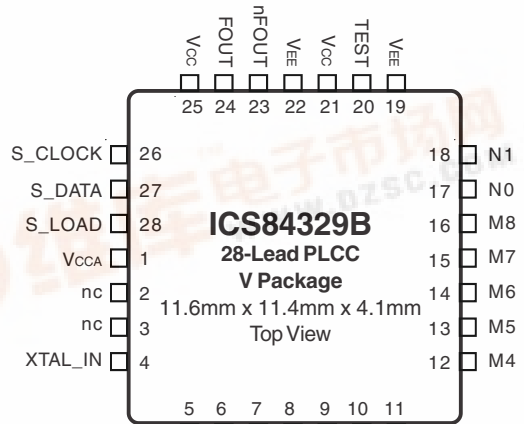



Integrated
Circuit
Systems, Inc.

ICS84329B

700MHz, LOW JITTER, CRYSTAL-TO-3.3V DIFFERENTIAL LVPECL FREQUENCY SYNTHESIZER

FUNCTIONAL DESCRIPTION

NOTE: The functional description that follows describes operation using a 16MHz crystal. Valid PLL loop divider values for different crystal or input frequencies are defined in the Input Frequency Characteristics, Table 6, NOTE 1.

The ICS84329B features a fully integrated PLL and therefore requires no external components for setting the loop bandwidth. A series-resonant, fundamental crystal is used as the input to the on-chip oscillator. The output of the oscillator is divided by 16 prior to the phase detector. With a 16MHz crystal this provides a 1MHz reference frequency. The VCO of the PLL operates over a range of 250MHz to 700MHz. The output of the M divider is also applied to the phase detector.

The phase detector and the M divider force the VCO output frequency to be M times the reference frequency by adjusting the VCO control voltage. Note that for some values of M (either too high or too low), the PLL will not achieve lock. The output of the VCO is scaled by a divider prior to being sent to each of the LVPECL output buffers. The divider provides a 50% output duty cycle.

The programmable features of the ICS84329B support two input modes to program the M divider and N output divider. The two input operational modes are parallel and serial. Figure 1 shows the timing diagram for each mode. In parallel mode the nP_LOAD input is LOW. The data on inputs M0 through M8 and N0 through N1 is passed directly to the M divider and

N output divider. On the LOW-to-HIGH transition of the nP_LOAD input, the data is latched and the M divider remains loaded until the next LOW transition on nP_LOAD or until a serial event occurs. The TEST output is Mode 000 (shift register out) when operating in the parallel input mode. The relationship between the VCO frequency, the crystal frequency and the M divider is defined as follows:

$$f_{VCO} = \frac{f_{xtal}}{16} \times M$$

The M value and the required values of M0 through M8 are shown in Table 3B, Programmable VCO Frequency Function Table. Valid M values for which the PLL will achieve lock are defined as $250 \leq M \leq 511$. The frequency out is defined as follows:

$$f_{out} = \frac{f_{VCO}}{N} = \frac{f_{xtal}}{16} \times \frac{M}{N}$$

Serial operation occurs when nP_LOAD is HIGH and S_LOAD is LOW. The shift register is loaded by sampling the S_DATA bits with the rising edge of S_CLOCK. The contents of the shift register are loaded into the M divider when S_LOAD transitions from LOW-to-HIGH. The M divide and N output divide values are latched on the HIGH-to-LOW transition of S_LOAD. If S_LOAD is held HIGH, data at the S_DATA input is passed directly to the M divider on each rising edge of S_CLOCK. The serial mode can be used to program the M and N bits and test bits T2:T0. The internal registers T2:T0 determine the state of the TEST output as follows:

| T2 | T1 | T0 | TEST Output | fOUT |
|----|----|----|---|---------------------|
| 0 | 0 | 0 | Shift Register Out | fOUT |
| 0 | 0 | 1 | High | fOUT |
| 0 | 1 | 0 | PLL Reference Xtal ÷ 16 | fOUT |
| 0 | 1 | 1 | VCO ÷ M (non 50% Duty M divider) | fOUT |
| 1 | 0 | 0 | fOUT LVCMOS Output Frequency < 200MHz | fOUT |
| 1 | 0 | 1 | Low | fOUT |
| 1 | 1 | 0 | S_CLOCK ÷ M (non 50% Duty Cycle M divider) | S_CLOCK ÷ N divider |
| 1 | 1 | 1 | fOUT ÷ 4 | fOUT |

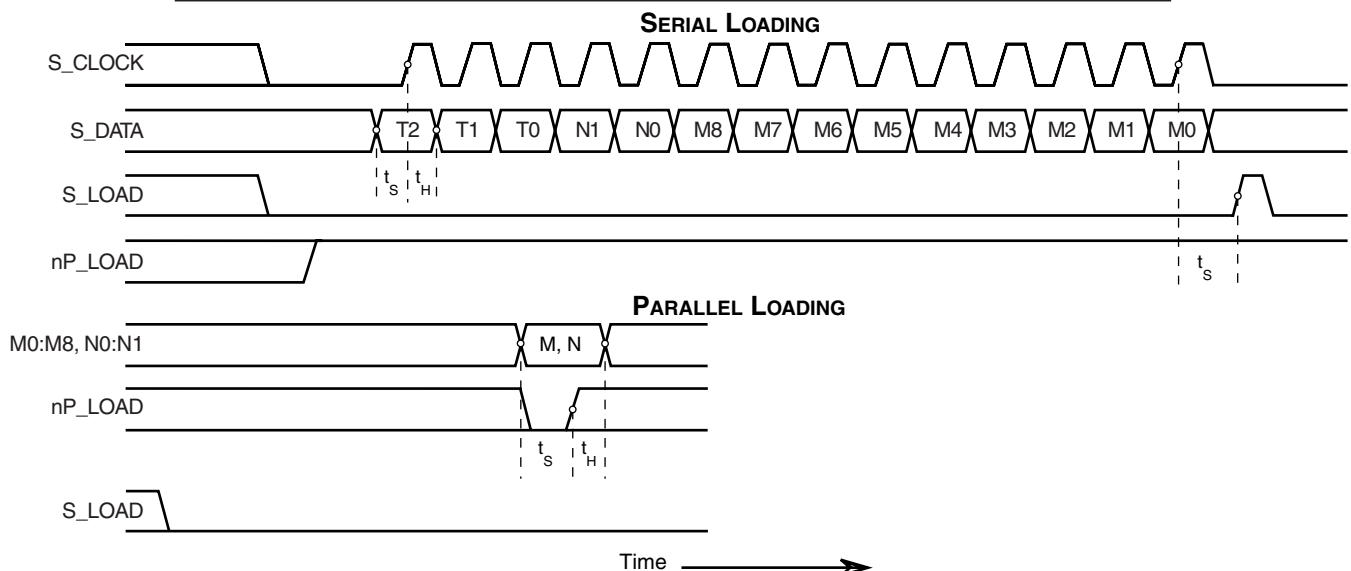

FIGURE 1. PARALLEL & SERIAL LOAD OPERATIONS



Integrated
Circuit
Systems, Inc.

ICS84329B

700MHz, LOW JITTER, CRYSTAL-TO-3.3V DIFFERENTIAL LVPECL FREQUENCY SYNTHESIZER

TABLE 1. PIN DESCRIPTIONS

| Name | Type | | Description |
|---------------------------------------|--------|----------|---|
| V _{CCA} | Power | | Analog supply pin. |
| XTAL_IN, XTAL_OUT | Input | | Crystal oscillator interface. XTAL_IN is the input. XTAL_OUT is the output. |
| OE | Input | Pullup | Output enable. When logic HIGH, the outputs are enabled (default). When logic LOW, the outputs are disabled and drive differential low: FOUT = LOW, nFOUT = HIGH. LVCMOS / LVTTTL interface levels. |
| nP_LOAD | Input | Pullup | Parallel load input. Determines when data present at M8:M0 is loaded into M divider, and when data present at N1:N0 sets the N output divide value. LVCMOS / LVTTTL interface levels. |
| M0, M1, M2, M3, M4, M5, M6, M7, M8 | Input | Pullup | M divider inputs. Data latched on LOW-to-HIGH transition of nP_LOAD input. LVCMOS / LVTTTL interface levels. |
| N0, N1 | Input | Pullup | Determines N output divider value as defined in Table 3C Function Table. LVCMOS / LVTTTL interface levels. |
| V _{EE} | Power | | Negative supply pins. |
| TEST | Output | | Test output which is used in the serial mode of operation. LVCMOS / LVTTTL interface levels. |
| V _{CC} | Power | | Core supply pins. |
| nFOUT, FOUT | Output | | Differential output for the synthesizer. 3.3V LVPECL interface levels. |
| S_CLOCK | Input | Pulldown | Clocks the serial data present at S_DATA input into the shift register on the rising edge of S_CLOCK. LVCMOS / LVTTTL interface levels. |
| S_DATA | Input | Pulldown | Shift register serial input. Data sampled on the rising edge of S_CLOCK. LVCMOS / LVTTTL interface levels. |
| S_LOAD | Input | Pulldown | Controls transition of data from shift register into the M divider. LVCMOS / LVTTTL interface levels. |

NOTE: *Pullup* and *Pulldown* refer to internal input resistors. See Table 2, Pin Characteristics, for typical values.

TABLE 2. PIN CHARACTERISTICS

| Symbol | Parameter | Test Conditions | Minimum | Typical | Maximum | Units |
|-----------------------|-------------------------|-----------------|---------|---------|---------|-------|
| C _{IN} | Input Capacitance | | | 4 | | pF |
| R _{PULLUP} | Input Pullup Resistor | | | 51 | | kΩ |
| R _{PULLDOWN} | Input Pulldown Resistor | | | 51 | | kΩ |



Integrated
Circuit
Systems, Inc.

ICS84329B

700MHz, LOW JITTER, CRYSTAL-TO-3.3V DIFFERENTIAL LVPECL FREQUENCY SYNTHESIZER

TABLE 3A. PARALLEL AND SERIAL MODE FUNCTION TABLE

| Inputs | | | | | | Conditions |
|---------|------|------|--------|---------|--------|---|
| nP_LOAD | M | N | S_LOAD | S_CLOCK | S_DATA | |
| X | X | X | X | X | X | Reset. M and N bits are all set HIGH. |
| L | Data | Data | X | X | X | Data on M and N inputs passed directly to M divider and N output divider. TEST mode 000. |
| ↑ | Data | Data | L | X | X | Data is latched into input registers and remains loaded until next LOW transition or until a serial event occurs. |
| H | X | X | L | ↑ | Data | Serial input mode. Shift register is loaded with data on S_DATA on each rising edge of S_CLOCK. |
| H | X | X | ↑ | L | Data | Contents of the shift register are passed to the M divider and N output divider. |
| H | X | X | ↓ | L | Data | M divide and N output divide values are latched. |
| H | X | X | L | X | X | Parallel or serial input do not affect shift registers. |

NOTE: L = LOW
 H = HIGH
 X = Don't care
 ↑ = Rising edge transition
 ↓ = Falling edge transition

TABLE 3B. PROGRAMMABLE VCO FREQUENCY FUNCTION TABLE

| VCO Frequency (MHz) | M Divide | 256 | 128 | 64 | 32 | 16 | 8 | 4 | 2 | 1 |
|---------------------|----------|-----|-----|----|----|----|----|----|----|----|
| | | M8 | M7 | M6 | M5 | M4 | M3 | M2 | M1 | M0 |
| 250 | 250 | 0 | 1 | 1 | 1 | 1 | 1 | 0 | 1 | 0 |
| 251 | 251 | 0 | 1 | 1 | 1 | 1 | 1 | 0 | 1 | 1 |
| 252 | 252 | 0 | 1 | 1 | 1 | 1 | 1 | 1 | 0 | 0 |
| 253 | 253 | 0 | 1 | 1 | 1 | 1 | 1 | 1 | 0 | 1 |
| • | • | • | • | • | • | • | • | • | • | • |
| • | • | • | • | • | • | • | • | • | • | • |
| 509 | 509 | 1 | 1 | 1 | 1 | 1 | 1 | 1 | 0 | 1 |
| 510 | 510 | 1 | 1 | 1 | 1 | 1 | 1 | 1 | 1 | 0 |
| 511 | 511 | 1 | 1 | 1 | 1 | 1 | 1 | 1 | 1 | 1 |

NOTE 1: These M divide values and the resulting frequencies correspond to a crystal frequency of 16MHz.

TABLE 3C. PROGRAMMABLE OUTPUT DIVIDER FUNCTION TABLE

| Inputs | | N Divider Value | Output Frequency (MHz) | |
|--------|----|-----------------|------------------------|---------|
| N1 | N0 | | Minimum | Maximum |
| 0 | 0 | 1 | 250 | 700 |
| 0 | 1 | 2 | 125 | 350 |
| 1 | 0 | 4 | 62.5 | 175 |
| 1 | 1 | 8 | 31.25 | 87.5 |

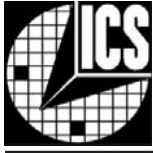

Integrated
Circuit
Systems, Inc.

ICS84329B

700MHz, LOW JITTER, CRYSTAL-TO-3.3V DIFFERENTIAL LVPECL FREQUENCY SYNTHESIZER

ABSOLUTE MAXIMUM RATINGS

| | |
|--|--------------------------|
| Supply Voltage, V_{CC} | 4.6V |
| Inputs, V_I | -0.5V to $V_{CC} + 0.5V$ |
| Outputs, I_O | |
| Continuous Current | 50mA |
| Surge Current | 100mA |
| Package Thermal Impedance, θ_{JA} | 37.8°C/W (0 lfpm) |
| Storage Temperature, T_{STG} | -65°C to 150°C |

NOTE: Stresses beyond those listed under Absolute Maximum Ratings may cause permanent damage to the device. These ratings are stress specifications only. Functional operation of product at these conditions or any conditions beyond those listed in the *DC Characteristics* or *AC Characteristics* is not implied. Exposure to absolute maximum rating conditions for extended periods may affect product reliability.

TABLE 4A. POWER SUPPLY DC CHARACTERISTICS, $V_{CC} = V_{CCA} = 3.3V \pm 5\%$, $T_A = 0^\circ C$ TO $70^\circ C$

| Symbol | Parameter | Test Conditions | Minimum | Typical | Maximum | Units |
|-----------|-----------------------|-----------------|---------|---------|---------|-------|
| V_{CC} | Core Supply Voltage | | 3.135 | 3.3 | 3.465 | V |
| V_{CCA} | Analog Supply Voltage | | 3.135 | 3.3 | 3.465 | V |
| I_{CC} | Power Supply Current | | | | 125 | mA |
| I_{CCA} | Analog Supply Current | | | | 15 | mA |

TABLE 4B. LVCMOS / LVTTTL DC CHARACTERISTICS, $V_{CC} = V_{CCA} = 3.3V \pm 5\%$, $T_A = 0^\circ C$ TO $70^\circ C$

| Symbol | Parameter | Test Conditions | Minimum | Typical | Maximum | Units |
|----------|-----------------------------|-------------------------------|--------------------------------|---------|----------------|---------|
| V_{IH} | Input High Voltage | | 2 | | $V_{CC} + 0.3$ | V |
| V_{IL} | Input Low Voltage | | -0.3 | | 0.8 | V |
| I_{IH} | Input High Current | M0-M8, N0, N1, OE, nP_LOAD | $V_{CC} = V_{IN} = 3.465V$ | | 5 | μA |
| | | S_LOAD, S_DATA, S_CLOCK | $V_{CC} = V_{IN} = 3.465V$ | | 150 | μA |
| I_{IL} | Input Low Current | M0-M8, N0, N1, OE, nP_LOAD | $V_{CC} = 3.465V, V_{IN} = 0V$ | -150 | | μA |
| | | S_LOAD, S_DATA, S_CLOCK | $V_{CC} = 3.465V, V_{IN} = 0V$ | -5 | | μA |
| V_{OH} | Output High Voltage; NOTE 1 | | 2.6 | | | V |
| V_{OL} | Output Low Voltage; NOTE 1 | | | | 0.5 | V |

NOTE 1: Outputs terminated with 50Ω to $V_{CC}/2$. See Parameter Measurement Information, 3.3V Output Load Test Circuit.

TABLE 4C. LVPECL DC CHARACTERISTICS, $V_{CC} = V_{CCA} = 3.3V \pm 5\%$, $T_A = 0^\circ C$ TO $70^\circ C$

| Symbol | Parameter | Test Conditions | Minimum | Typical | Maximum | Units |
|-------------|-----------------------------------|-----------------|----------------|---------|----------------|-------|
| V_{OH} | Output High Voltage; NOTE 1 | | $V_{CC} - 1.4$ | | $V_{CC} - 0.9$ | V |
| V_{OL} | Output Low Voltage; NOTE 1 | | $V_{CC} - 2.0$ | | $V_{CC} - 1.7$ | V |
| V_{SWING} | Peak-to-Peak Output Voltage Swing | | 0.6 | | 1.0 | V |

NOTE 1: Outputs terminated with 50Ω to $V_{CC} - 2V$.



Integrated
Circuit
Systems, Inc.

ICS84329B

700MHz, LOW JITTER, CRYSTAL-TO-3.3V DIFFERENTIAL LVPECL FREQUENCY SYNTHESIZER

TABLE 5. CRYSTAL CHARACTERISTICS

| Parameter | Test Conditions | Minimum | Typical | Maximum | Units |
|------------------------------------|-----------------|-------------|---------|---------|----------|
| Mode of Oscillation | | Fundamental | | | |
| Frequency | | 10 | | 25 | MHz |
| Equivalent Series Resistance (ESR) | | | | 50 | Ω |
| Shunt Capacitance | | | | 7 | pF |
| Drive Level | | | | 1 | mW |

TABLE 6. INPUT FREQUENCY CHARACTERISTICS, $V_{CC} = V_{CCA} = 3.3V \pm 5\%$, $T_A = 0^\circ C$ TO $70^\circ C$

| Symbol | Parameter | Test Conditions | Minimum | Typical | Maximum | Units |
|----------|-----------------|-----------------|---------|---------|---------|-------|
| f_{IN} | Input Frequency | XTAL; NOTE 1 | 10 | | 25 | MHz |
| | | S_CLOCK | | | 50 | MHz |

NOTE 1: For the crystal frequency range the M value must be set to achieve the minimum or maximum VCO frequency range of 250MHz or 700MHz. Using the minimum frequency of 10MHz valid values of M are $400 \leq M \leq 511$. Using the maximum frequency of 25MHz valid values of M are $160 \leq M \leq 448$.

TABLE 7. AC CHARACTERISTICS, $V_{CC} = V_{CCA} = 3.3V \pm 5\%$, $T_A = 0^\circ C$ TO $70^\circ C$

| Symbol | Parameter | Test Conditions | Minimum | Typical | Maximum | Units |
|----------------|----------------------------------|----------------------|---------|---------|---------|-------|
| F_{OUT} | Output Frequency | | | | 700 | MHz |
| $f_{jit(per)}$ | Period Jitter, RMS; NOTE 1, 2 | $f_{OUT} \geq 65MHz$ | | | 5.5 | ps |
| | | $f_{OUT} < 65MHz$ | | | 12 | ps |
| $f_{jit(cc)}$ | Cycle-to-Cycle Jitter; NOTE 1, 2 | $f_{OUT} \geq 50MHz$ | | | 35 | ps |
| | | $f_{OUT} < 50MHz$ | | | 50 | ps |
| t_R / t_F | Output Rise/Fall Time | 20% to 80% | 300 | | 800 | ps |
| t_S | Setup Time | | 5 | | | ns |
| t_H | Hold Time | | 5 | | | ns |
| t_L | PLL Lock Time | | | | 10 | ms |
| odc | Output Duty Cycle | | 45 | 50 | 55 | % |

See Parameter Measurement Information section.

Characterized using a 16MHz XTAL.

NOTE 1: This parameter is defined in accordance with JEDEC Standard 65

NOTE 2: See Applications section.



Integrated
Circuit
Systems, Inc.

ICS84329B

700MHz, LOW JITTER, CRYSTAL-TO-3.3V
DIFFERENTIAL LVPECL FREQUENCY SYNTHESIZER

PARAMETER MEASUREMENT INFORMATION

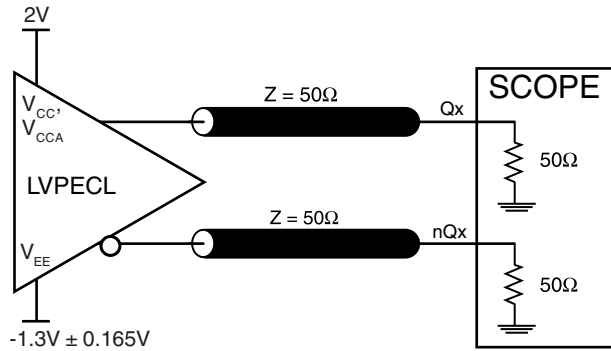

3.3V OUTPUT LOAD AC TEST CIRCUIT

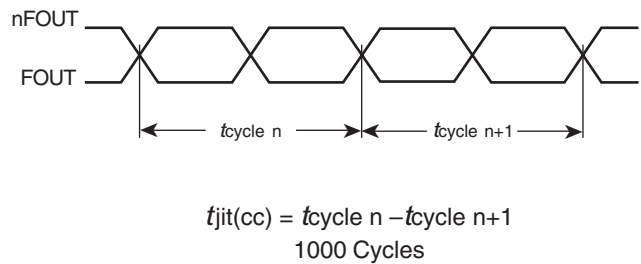

CYCLE-TO-CYCLE JITTER

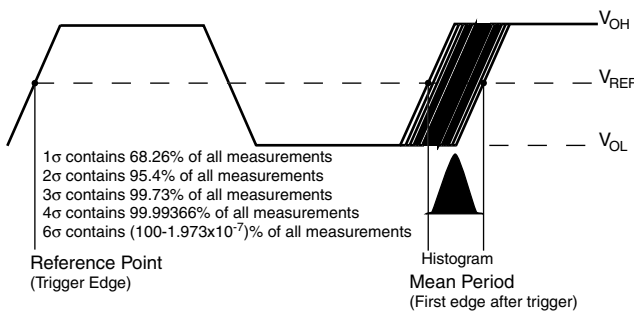

PERIOD JITTER

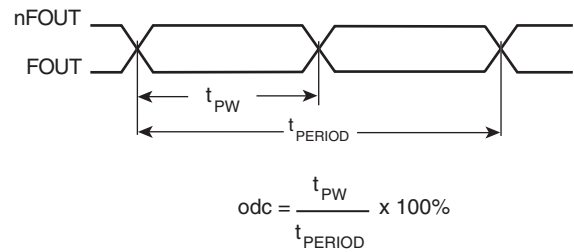

OUTPUT DUTY CYCLE/PULSE WIDTH/PERIOD

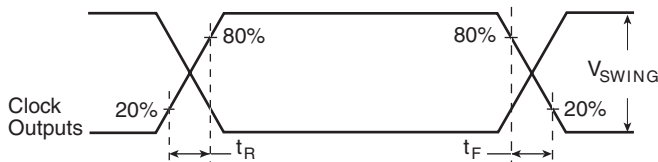

OUTPUT RISE/FALL TIME

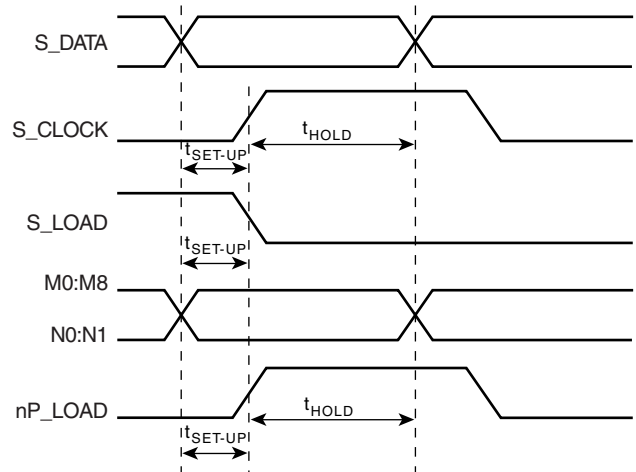

SETUP AND HOLD



APPLICATION INFORMATION

POWER SUPPLY FILTERING TECHNIQUES

As in any high speed analog circuitry, the power supply pins are vulnerable to random noise. The ICS84329B provides separate power supplies to isolate any high switching noise from the outputs to the internal PLL. V_{CC} and V_{CCA} should be individually connected to the power supply plane through vias, and bypass capacitors should be used for each pin. To achieve optimum jitter performance, power supply isolation is required. *Figure 2* illustrates how a 10Ω resistor along with a $10\mu\text{F}$ and a $.01\mu\text{F}$ bypass capacitor should be connected to each V_{CCA} pin. The 10Ω resistor can also be replaced by a ferrite bead.

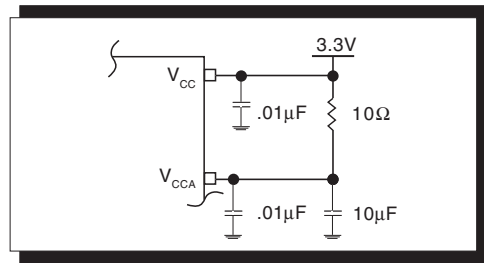

FIGURE 2. POWER SUPPLY FILTERING

CRYSTAL INPUT INTERFACE

The ICS84329B has been characterized with 18pF parallel resonant crystals. The capacitor values, C1 and C2, shown in *Figure 3* below were determined using a 25MHz, 18pF

parallel resonant crystal and were chosen to minimize the ppm error. The optimum C1 and C2 values can be slightly adjusted for different board layouts.

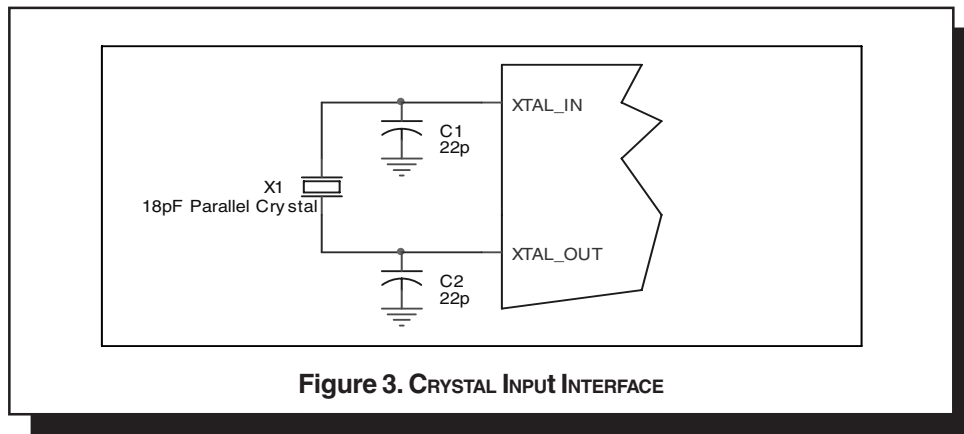

Figure 3. CRYSTAL INPUT INTERFACE

RECOMMENDATIONS FOR UNUSED INPUT PINS

INPUTS:

LVC MOS CONTROL PINS:

All control pins have internal pull-ups or pull-downs; additional resistance is not required but can be added for additional protection. A $1\text{k}\Omega$ resistor can be used.



Integrated
Circuit
Systems, Inc.

ICS84329B

700MHz, LOW JITTER, CRYSTAL-TO-3.3V
DIFFERENTIAL LVPECL FREQUENCY SYNTHESIZER

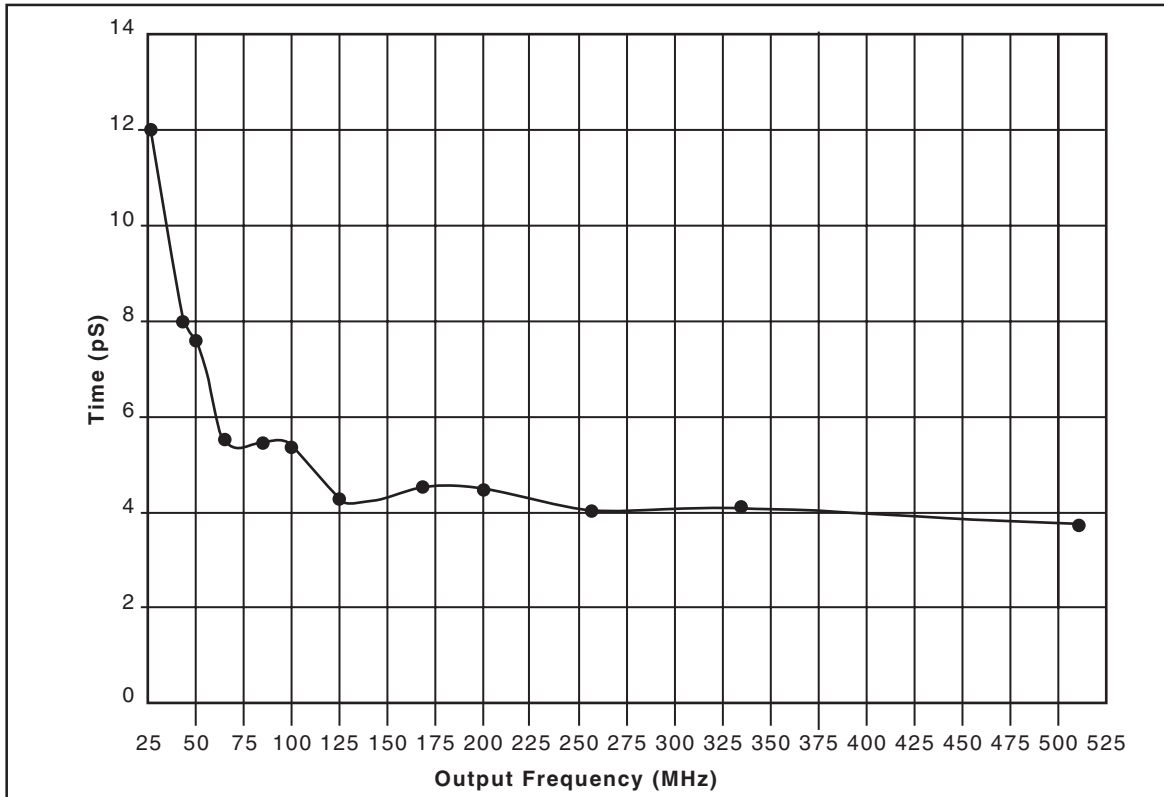

FIGURE 4A. RMS JITTER vs. f_{OUT} (using a 16MHz XTAL)

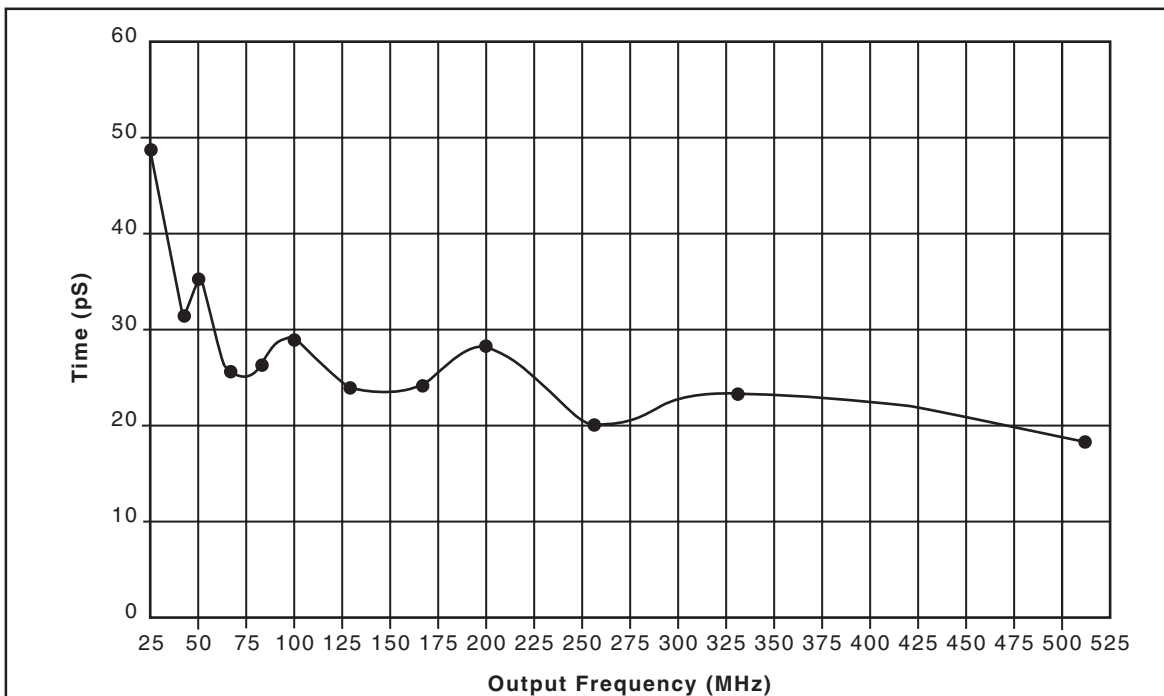
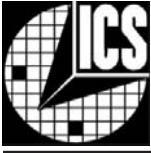

FIGURE 4B. CYCLE-TO-CYCLE JITTER vs. f_{OUT} (using a 16MHz XTAL)



Integrated
Circuit
Systems, Inc.

ICS84329B

700MHz, LOW JITTER, CRYSTAL-TO-3.3V DIFFERENTIAL LVPECL FREQUENCY SYNTHESIZER

LAYOUT GUIDELINE

The schematic of the ICS84329B layout example used in this layout guideline is shown in *Figure 5A*. The ICS84329B recommended PCB board layout for this example is shown in *Figure 5B*. This layout example is used as a general guideline. The

layout in the actual system will depend on the selected component types, the density of the components, the density of the traces, and the stack up of the P.C. board.

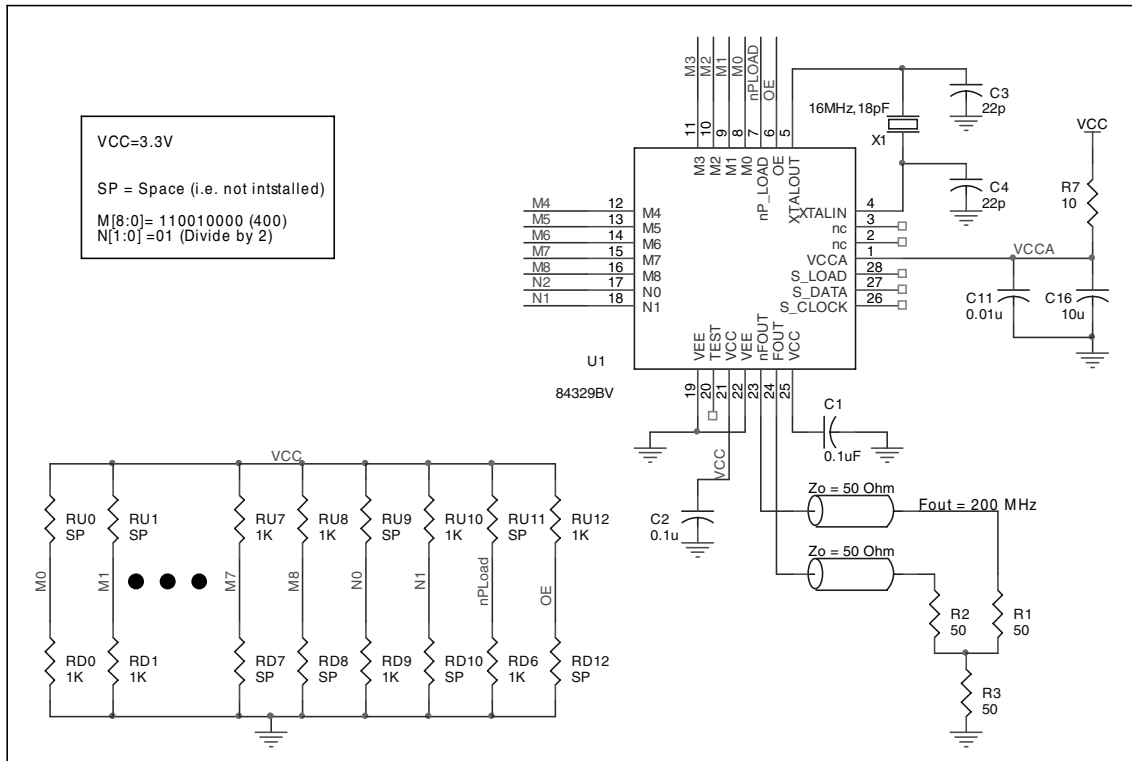

FIGURE 5A. SCHEMATIC OF RECOMMENDED LAYOUT FOR 28 LEAD PLCC



ICS84329B

700MHz, LOW JITTER, CRYSTAL-TO-3.3V DIFFERENTIAL LVPECL FREQUENCY SYNTHESIZER

The following component footprints are used in this layout example:

All the resistors and capacitors are size 0603.

POWER AND GROUNDING

Place the decoupling capacitors C1, C2 and C3, as close as possible to the power pins. If space allows, placement of the decoupling capacitor on the component side is preferred. This can reduce unwanted inductance between the decoupling capacitor and the power pin caused by the via.

Maximize the power and ground pad sizes and number of vias capacitors. This can reduce the inductance between the power and ground planes and the component power and ground pins.

The RC filter consisting of R7, C11, and C16 should be placed as close to the V_{CCA} pin as possible.

CLOCK TRACES AND TERMINATION

Poor signal integrity can degrade the system performance or cause system failure. In synchronous high-speed digital systems, the clock signal is less tolerant to poor signal integrity than other signals. Any ringing on the rising or falling edge or excessive ring back can cause system failure. The shape of the trace and the trace delay might be restricted by the available space on the board and the component location. While routing the traces, the clock signal traces should be routed first and should be locked prior to routing other signal traces.

- The differential 50Ω output traces should have the same length.
- Avoid sharp angles on the clock trace. Sharp angle turns cause the characteristic impedance to change on the transmission lines.
- Keep the clock traces on the same layer. Whenever possible, avoid placing vias on the clock traces. Placement of vias on the traces can affect the trace characteristic impedance and hence degrade signal integrity.
- To prevent cross talk, avoid routing other signal traces in parallel with the clock traces. If running parallel traces is unavoidable, allow a separation of at least three trace widths between the differential clock trace and the other signal trace.
- Make sure no other signal traces are routed between the clock trace pair.
- The matching termination resistors should be located as close to the receiver input pins as possible.

CRYSTAL

The crystal X1 should be located as close as possible to the pins 4 (XTAL_IN) and 5 (XTAL_OUT). The trace length between the X1 and U1 should be kept to a minimum to avoid unwanted parasitic inductance and capacitance. Other signal traces should not be routed near the crystal traces.

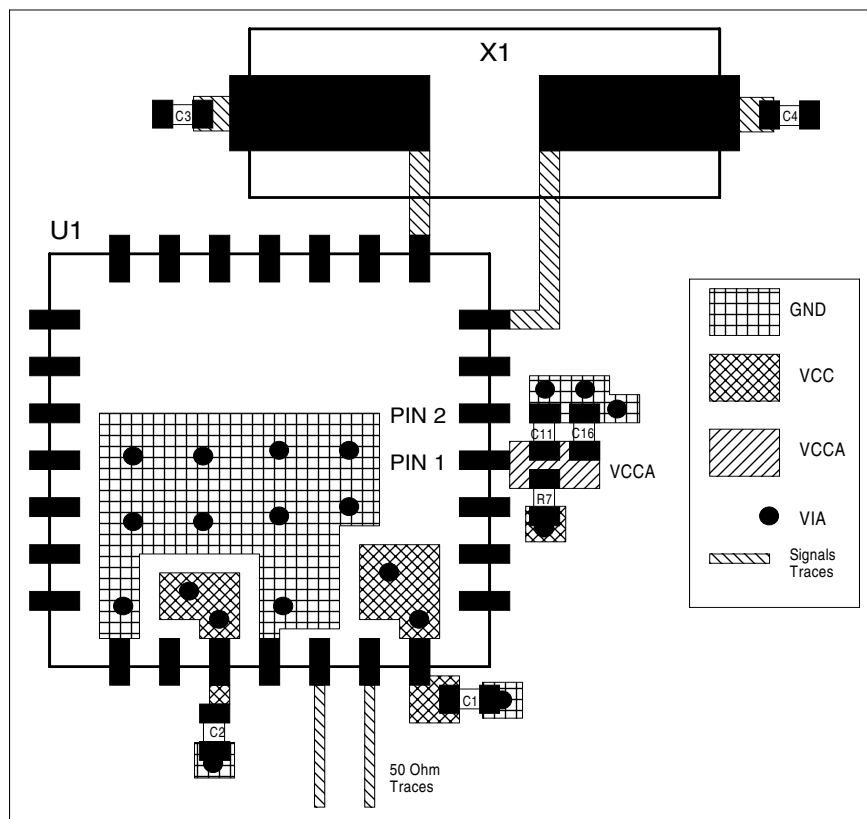

FIGURE 5B. PCB BOARD LAYOUT FOR ICS84329B 28 LEAD PLCC



Integrated
Circuit
Systems, Inc.

ICS84329B

700MHz, LOW JITTER, CRYSTAL-TO-3.3V DIFFERENTIAL LVPECL FREQUENCY SYNTHESIZER

TERMINATION FOR LVPECL OUTPUTS

The clock layout topology shown below is a typical termination for LVPECL outputs. The two different layouts mentioned are recommended only as guidelines.

FOUT and nFOUT are low impedance follower outputs that generate ECL/LVPECL compatible outputs. Therefore, terminating resistors (DC current path to ground) or current sources must be used for functionality. These outputs are

designed to drive 50Ω transmission lines. Matched impedance techniques should be used to maximize operating frequency and minimize signal distortion. *Figures 6A and 6B* show two different layouts which are recommended only as guidelines. Other suitable clock layouts may exist and it would be recommended that the board designers simulate to guarantee compatibility across all printed circuit and clock component process variations.

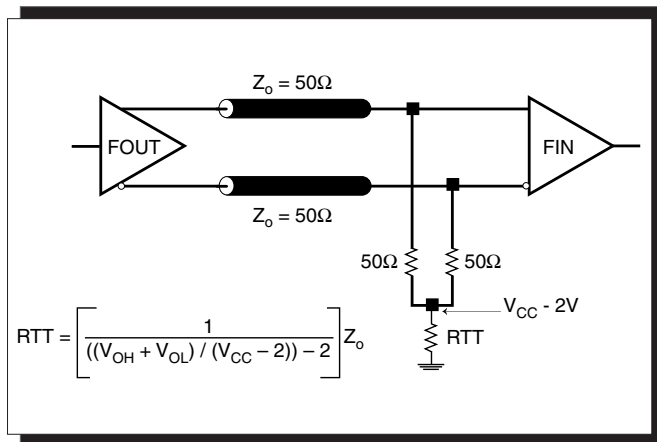

FIGURE 6A. LVPECL OUTPUT TERMINATION

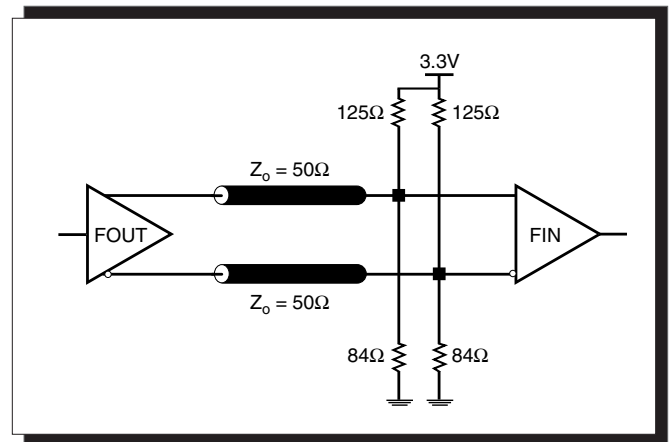
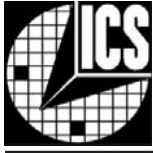

FIGURE 6B. LVPECL OUTPUT TERMINATION



POWER CONSIDERATIONS

This section provides information on power dissipation and junction temperature for the ICS84329B. Equations and example calculations are also provided.

1. Power Dissipation.

The total power dissipation for the ICS84329B is the sum of the core power plus the power dissipated in the load(s). The following is the power dissipation for $V_{CC} = 3.3V + 5\% = 3.465V$, which gives worst case results.

NOTE: Please refer to Section 3 for details on calculating power dissipated in the load.

- Power (core)_{MAX} = $V_{CC_MAX} * I_{EE_MAX} = 3.465V * 140mA = 485mW$
- Power (outputs)_{MAX} = **30mW/Loaded Output pair**

Total Power_{MAX} (3.465V, with all outputs switching) = 485mW + 30mW = **515mW**

2. Junction Temperature.

Junction temperature, T_j, is the temperature at the junction of the bond wire and bond pad and directly affects the reliability of the device. The maximum recommended junction temperature for HiPerClockS™ devices is 125°C.

The equation for T_j is as follows: $T_j = \theta_{JA} * Pd_total + T_A$

T_j = Junction Temperature

θ_{JA} = Junction-to-Ambient Thermal Resistance

Pd_{total} = Total Device Power Dissipation (example calculation is in section 1 above)

T_A = Ambient Temperature

In order to calculate junction temperature, the appropriate junction-to-ambient thermal resistance θ_{JA} must be used. Assuming a moderate air flow of 200 linear feet per minute and a multi-layer board, the appropriate value is 31.1°C/W per Table 8A below.

Therefore, T_j for an ambient temperature of 70°C with all outputs switching is:

$70^\circ C + 0.515W * 31.1^\circ C/W = 86^\circ C$. This is well below the limit of 125°C.

This calculation is only an example. T_j will obviously vary depending on the number of loaded outputs, supply voltage, air flow, and the type of board (single layer or multi-layer).

TABLE 8A. THERMAL RESISTANCE θ_{JA} FOR 28-PIN PLCC, FORCED CONVECTION

| θ_{JA} by Velocity (Linear Feet per Minute) | | | |
|---|----------|----------|----------|
| | 0 | 200 | 500 |
| Multi-Layer PCB, JEDEC Standard Test Boards | 37.8°C/W | 31.1°C/W | 28.3°C/W |
| NOTE: Most modern PCB designs use multi-layered boards. The data in the second row pertains to most designs. | | | |

TABLE 8B. THERMAL RESISTANCE θ_{JA} FOR 32-PIN LQFP, FORCED CONVECTION

| θ_{JA} by Velocity (Linear Feet per Minute) | | | |
|---|----------|----------|----------|
| | 0 | 200 | 500 |
| Single-Layer PCB, JEDEC Standard Test Boards | 67.8°C/W | 55.9°C/W | 50.1°C/W |
| Multi-Layer PCB, JEDEC Standard Test Boards | 47.9°C/W | 42.1°C/W | 39.4°C/W |
| NOTE: Most modern PCB designs use multi-layered boards. The data in the second row pertains to most designs. | | | |



3. Calculations and Equations.

The purpose of this section is to derive the power dissipated into the load.

LVPECL output driver circuit and termination are shown in the *Figure 7*.

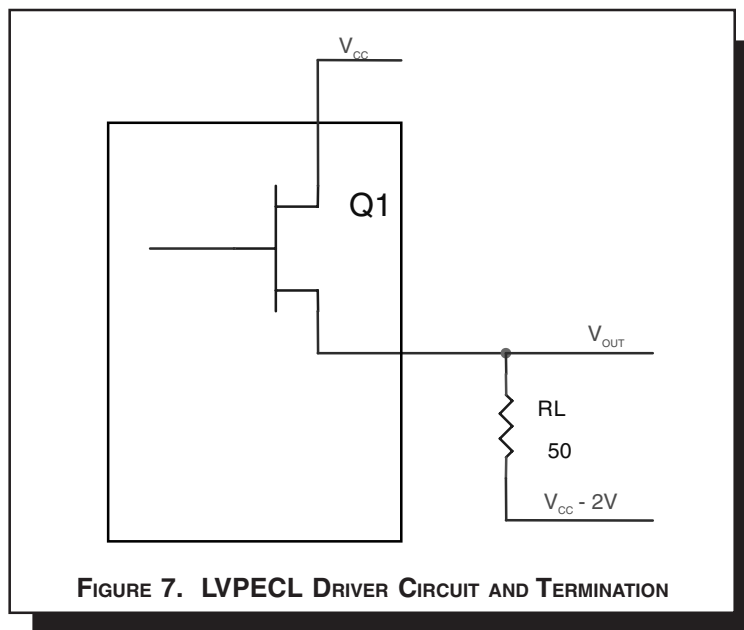

To calculate worst case power dissipation into the load, use the following equations which assume a 50Ω load, and a termination voltage of $V_{CC} - 2V$.

- For logic high, $V_{OUT} = V_{OH_MAX} = V_{CC_MAX} - 0.9V$

$$(V_{CC_MAX} - V_{OH_MAX}) = 0.9V$$

- For logic low, $V_{OUT} = V_{OL_MAX} = V_{CC_MAX} - 1.7V$

$$(V_{CC_MAX} - V_{OL_MAX}) = 1.7V$$

Pd_H is power dissipation when the output drives high.

Pd_L is the power dissipation when the output drives low.

$$Pd_H = [(V_{OH_MAX} - (V_{CC_MAX} - 2V))/R_L] * (V_{CC_MAX} - V_{OH_MAX}) = [(2V - (V_{CC_MAX} - V_{OH_MAX}))/R_L] * (V_{CC_MAX} - V_{OH_MAX}) = [(2V - 0.9V)/50\Omega] * 0.9V = 19.8mW$$

$$Pd_L = [(V_{OL_MAX} - (V_{CC_MAX} - 2V))/R_L] * (V_{CC_MAX} - V_{OL_MAX}) = [(2V - (V_{CC_MAX} - V_{OL_MAX}))/R_L] * (V_{CC_MAX} - V_{OL_MAX}) = [(2V - 1.7V)/50\Omega] * 1.7V = 10.2mW$$

Total Power Dissipation per output pair = $Pd_H + Pd_L = 30mW$



Integrated
Circuit
Systems, Inc.

ICS84329B
700MHz, LOW JITTER, CRYSTAL-TO-3.3V
DIFFERENTIAL LVPECL FREQUENCY SYNTHESIZER

RELIABILITY INFORMATION

TABLE 9A. θ_{JA} VS. AIR FLOW TABLE FOR 28 LEAD PLCC

| θ_{JA} by Velocity (Linear Feet per Minute) | | | |
|---|----------|------------|------------|
| | 0 | 200 | 500 |
| Multi-Layer PCB, JEDEC Standard Test Boards | 37.8°C/W | 31.1°C/W | 28.3°C/W |
| NOTE: Most modern PCB designs use multi-layered boards. The data in the second row pertains to most designs. | | | |

TABLE 9B. θ_{JA} VS. AIR FLOW TABLE FOR 32 LEAD LQFP

| θ_{JA} by Velocity (Linear Feet per Minute) | | | |
|---|----------|------------|------------|
| | 0 | 200 | 500 |
| Single-Layer PCB, JEDEC Standard Test Boards | 67.8°C/W | 55.9°C/W | 50.1°C/W |
| Multi-Layer PCB, JEDEC Standard Test Boards | 47.9°C/W | 42.1°C/W | 39.4°C/W |
| NOTE: Most modern PCB designs use multi-layered boards. The data in the second row pertains to most designs. | | | |

TRANSISTOR COUNT

The transistor count for ICS84329B is: 4408

Pin compatible with the MC12429



Integrated
Circuit
Systems, Inc.

ICS84329B

700MHz, LOW JITTER, CRYSTAL-TO-3.3V
DIFFERENTIAL LVPECL FREQUENCY SYNTHESIZER

PACKAGE OUTLINE - V SUFFIX FOR 28 LEAD PLCC

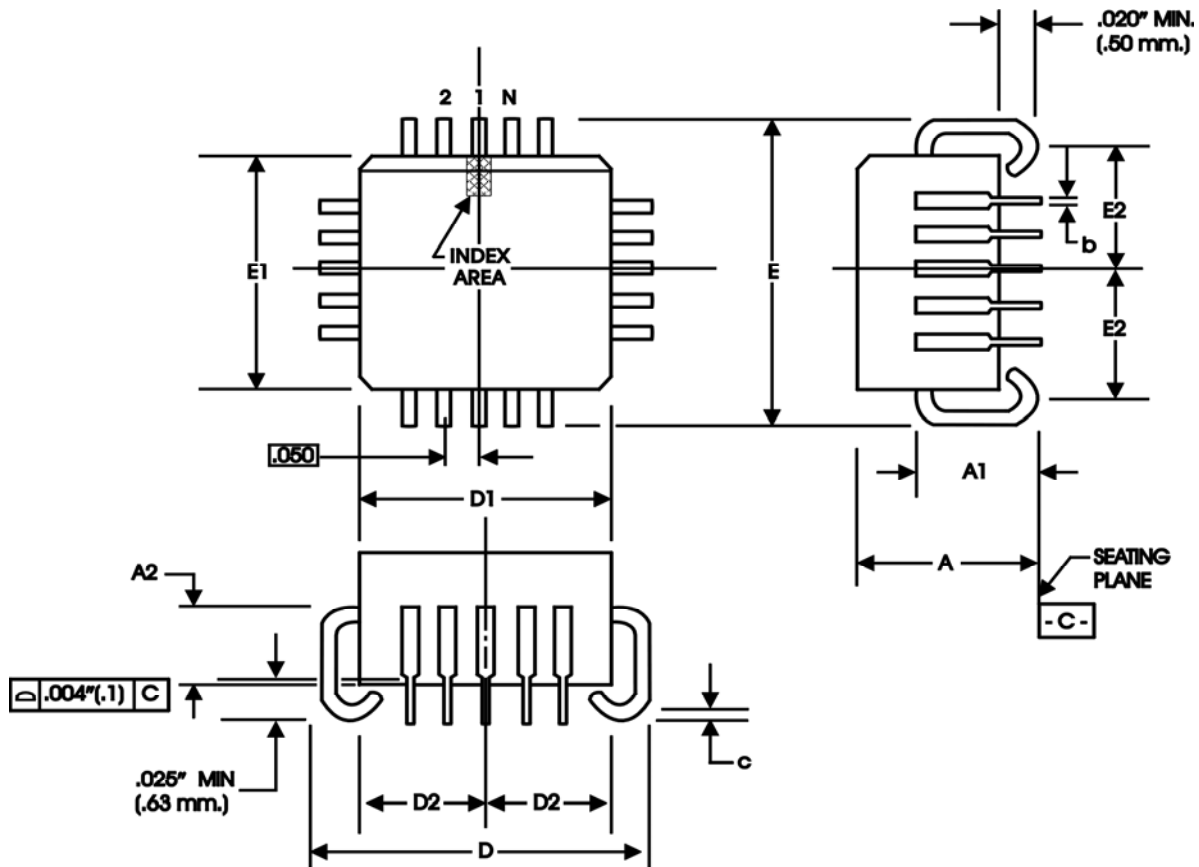

TABLE 10A. PACKAGE DIMENSIONS

| JEDEC VARIATION ALL DIMENSIONS IN MILLIMETERS | | |
|--|---------|---------|
| SYMBOL | MINIMUM | MAXIMUM |
| N | 28 | |
| A | 4.19 | 4.57 |
| A1 | 2.29 | 3.05 |
| A2 | 1.57 | 2.11 |
| b | 0.33 | 0.53 |
| c | 0.19 | 0.32 |
| D | 12.32 | 12.57 |
| D1 | 11.43 | 11.58 |
| D2 | 4.85 | 5.56 |
| E | 12.32 | 12.57 |
| E1 | 11.43 | 11.58 |
| E2 | 4.85 | 5.56 |

Reference Document: JEDEC Publication 95, MS-018



Integrated
Circuit
Systems, Inc.

ICS84329B

700MHz, LOW JITTER, CRYSTAL-TO-3.3V
DIFFERENTIAL LVPECL FREQUENCY SYNTHESIZER

PACKAGE OUTLINE - Y SUFFIX 32 LEAD LQFP

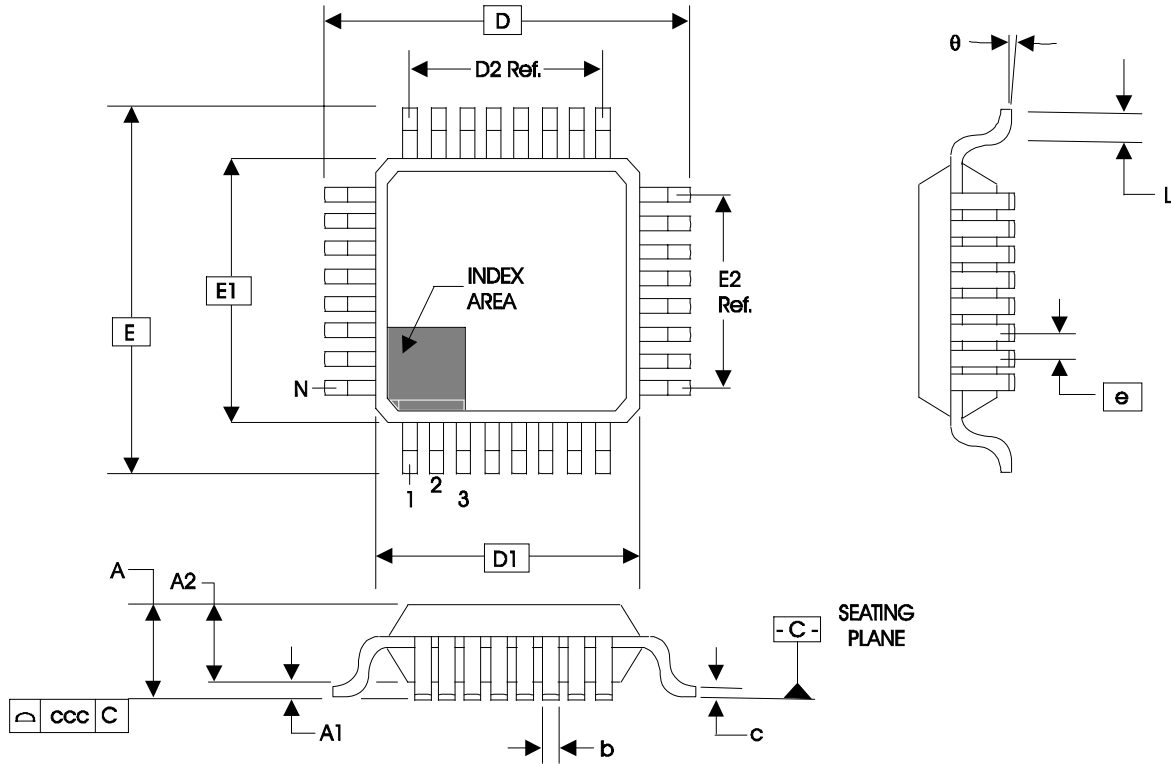

TABLE 10B. PACKAGE DIMENSIONS

| JEDEC VARIATION ALL DIMENSIONS IN MILLIMETERS | | | |
|--|------------|---------|---------|
| SYMBOL | BBA | | |
| | MINIMUM | NOMINAL | MAXIMUM |
| N | 32 | | |
| A | -- | -- | 1.60 |
| A1 | 0.05 | -- | 0.15 |
| A2 | 1.35 | 1.40 | 1.45 |
| b | 0.30 | 0.37 | 0.45 |
| c | 0.09 | -- | 0.20 |
| D | 9.00 BASIC | | |
| D1 | 7.00 BASIC | | |
| D2 | 5.60 Ref. | | |
| E | 9.00 BASIC | | |
| E1 | 7.00 BASIC | | |
| E2 | 5.60 Ref. | | |
| e | 0.80 BASIC | | |
| L | 0.45 | 0.60 | 0.75 |
| theta | 0° | -- | 7° |
| ccc | -- | -- | 0.10 |



Integrated
Circuit
Systems, Inc.

ICS84329B

700MHz, LOW JITTER, CRYSTAL-TO-3.3V DIFFERENTIAL LVPECL FREQUENCY SYNTHESIZER

TABLE 11. ORDERING INFORMATION

| Part/Order Number | Marking | Package | Shipping Packaging | Temperature |
|-------------------|---------------|--------------------------|--------------------|-------------|
| ICS84329BV | ICS84329BV | 28 Lead PLCC | Tube | 0°C to 70°C |
| ICS84329BVT | ICS84329BV | 28 Lead PLCC | 500 Tape & Reel | 0°C to 70°C |
| ICS84329BVLFF | ICS84329BVLFF | 28 Lead "Lead-Free" PLCC | Tube | 0°C to 70°C |
| ICS84329BVLFT | ICS84329BVLFF | 28 Lead "Lead-Free" PLCC | 500 Tape & Reel | 0°C to 70°C |
| ICS84329BY | ICS84329BY | 32 Lead LQFP | Tray | 0°C to 70°C |
| ICS84329BYT | ICS84329BY | 32 Lead LQFP | 1000 Tape & Reel | 0°C to 70°C |
| ICS84329BYLFF | ICS84329BYLFF | 32 Lead "Lead-Free" LQFP | Tray | 0°C to 70°C |
| ICS84329BYLFT | ICS84329BYLFF | 32 Lead "Lead-Free" LQFP | 1000 Tape & Reel | 0°C to 70°C |

NOTE: Parts that are ordered with an "LF" suffix to the part number are the Pb-Free configuration and are RoHS compliant.



Integrated
Circuit
Systems, Inc.

ICS84329B
700MHz, LOW JITTER, CRYSTAL-TO-3.3V
DIFFERENTIAL LVPECL FREQUENCY SYNTHESIZER

| REVISION HISTORY SHEET | | | | |
|------------------------|-----------|------|---|----------|
| Rev | Table | Page | Description of Change | Date |
| A | | 1 | Features Section - added "Parallel resonant" to crystal bullet. | 12/15/04 |
| B | T5 T11 | 1 | Features Section - corrected Output frequency range from 25MHz to 31.25MHz. Added Lead-Free bullet. | 6/10/05 |
| | | 2 | Updated Parallel & Serial Load Operations. | |
| | | 6 | Crystal Table - added Drive Level. | |
| B | T11 | 17 | Ordering Information Table - added Lead-Free part numbers and note. | 1/18/06 |
| | | 8 | Power Supply Filtering Techniques - added ferrite bead sentence. | |
| | | 8 | Added <i>Recommendations for Unused Input and Output Pins</i> . | |
| | | 18 | Ordering Information Table - added Lead-Free marking. | |