

NB2309A

3.3 V Zero Delay Clock Buffer

The NB2309A is a versatile, 3.3 V zero delay buffer designed to distribute high-speed clocks. It accepts one reference input and drives out nine low-skew clocks. It is available in a 16 pin package.

The -1H version of the NB2309A operates at up to 133 MHz, and has higher drive than the -1 devices. All parts have on-chip PLL's that lock to an input clock on the REF pin. The PLL feedback is on-chip and is obtained from the CLKOUT pad.

The NB2309A has two banks of four outputs each, which can be controlled by the Select inputs as shown in the Select Input Decoding Table. If all the output clocks are not required, Bank B can be three-stated. The select inputs also allow the input clock to be directly applied to the outputs for chip and system testing purposes.

Multiple NB2309A devices can accept the same input clock and distribute it. In this case the skew between the outputs of the two devices is guaranteed to be less than 700 ps.

All outputs have less than 200 ps of cycle-to-cycle jitter. The input and output propagation delay is guaranteed to be less than 350 ps, and the output to output skew is guaranteed to be less than 250 ps.

The NB2309A is available in two different configurations, as shown in the ordering information table. The NB2309A1 is the base part. The NB2309Ax1H* is the high drive version of the -1 and its rise and fall times are much faster than -1 part.

Features

- 15 MHz to 133 MHz Operating Range, Compatible with CPU and PCI Bus Frequencies
- Zero Input - Output Propagation Delay
- Multiple Low-Skew Outputs
- Output-Output Skew Less than 250 ps
- Device-Device Skew Less than 700 ps
- One Input Drives 9 Outputs, Grouped as 4 + 4 + 1
- Less than 200 ps Cycle-to-Cycle Jitter is Compatible with Pentium® Based Systems
- Test Mode to Bypass PLL
- Available in 16 Pin, 150 mil SOIC and 4.4 mm TSSOP
- 3.3 V Operation, Advanced 0.35 μ CMOS Technology
- These are Pb-Free Devices**



ON Semiconductor®

<http://onsemi.com>

MARKING DIAGRAMS*

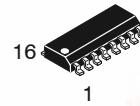

SOIC-16
D SUFFIX
CASE 751B

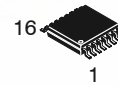
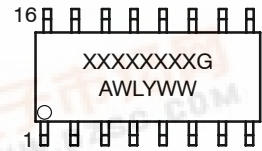

TSSOP-16
DT SUFFIX
CASE 948F

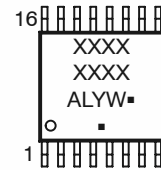

- XXXX = Device Code
- A = Assembly Location
- WL, L = Wafer Lot
- Y = Year
- W, WW = Work Week
- G or ■ = Pb-Free Package

*For additional marking information, refer to Application Note AND8002/D.

ORDERING INFORMATION

See detailed ordering and shipping information in the package dimensions section on page 7 of this data sheet.

*x = C for Commercial; I for Industrial.

**For additional information on our Pb-Free strategy and soldering details, please download the ON Semiconductor Soldering and Mounting Techniques Reference Manual, SOLDERRM/D.



NB2309A

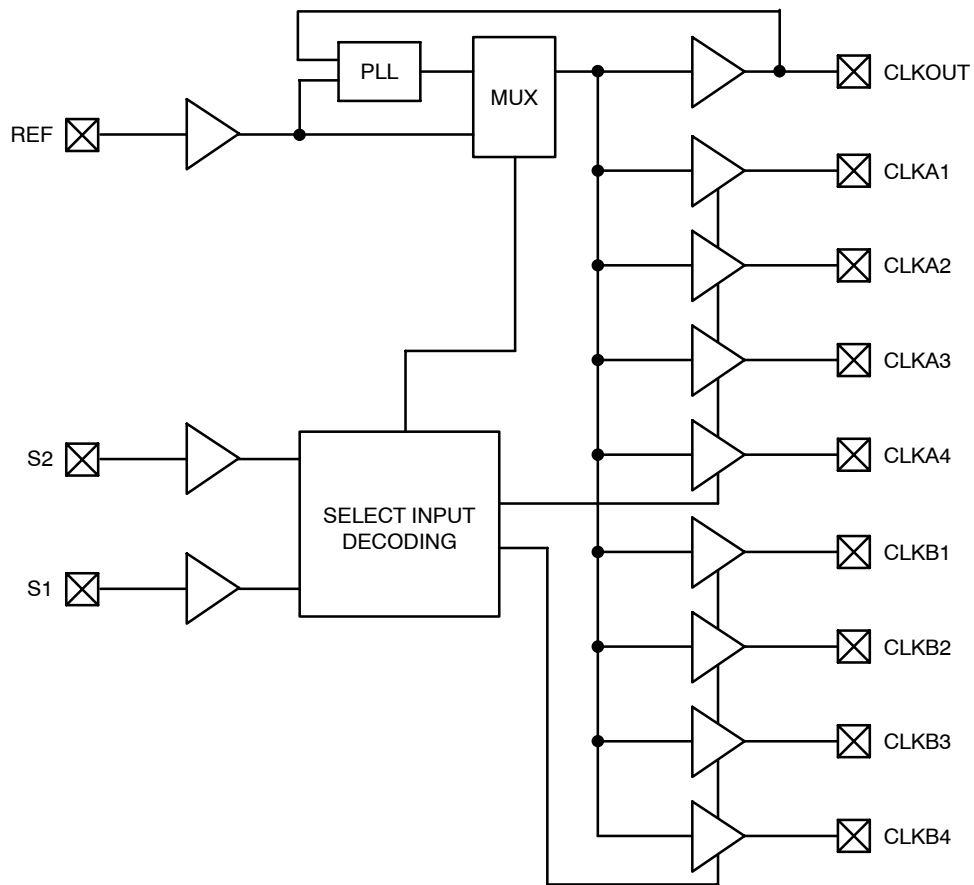

Figure 1. Block Diagram

Table 1. SELECT INPUT DECODING

S2	S1	Clock A1 - A4	Clock B1 - B4	CLKOUT (Note 1)	Output Source	PLL ShutDown
0	0	Three-state	Three-state	Driven	PLL	N
0	1	Driven	Three-state	Driven	PLL	N
1	0	Driven	Driven	Driven	Reference	Y
1	1	Driven	Driven	Driven	PLL	N

1. This output is driven and has an internal feedback for the PLL. The load on this output can be adjusted to change the skew between the reference and the output.

NB2309A

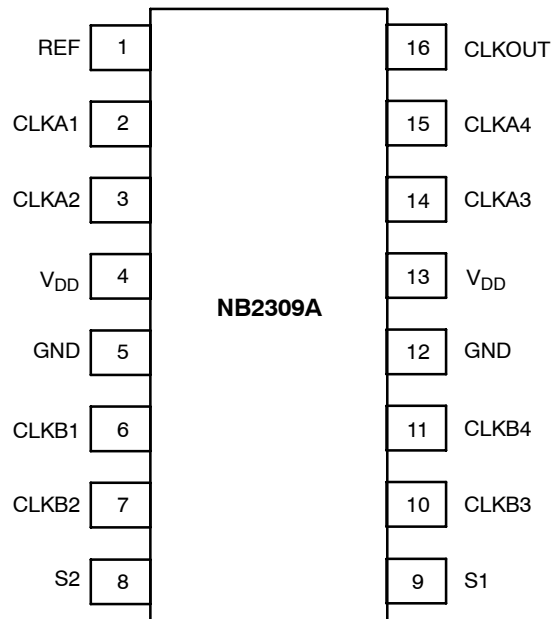

Figure 2. Pin Configuration

Table 2. PIN DESCRIPTION

Pin #	Pin Name	Description
1	REF (Note 2)	Input reference frequency, 5 V tolerant input.
2	CLKA1 (Note 3)	Buffered clock output, Bank A.
3	CLKA2 (Note 3)	Buffered clock output, Bank A.
4	V _{DD}	3.3 V supply.
5	GND	Ground.
6	CLKB1 (Note 3)	Buffered clock output, Bank B.
7	CLKB2 (Note 3)	Buffered clock output, Bank B.
8	S2 (Note 4)	Select input, bit 2.
9	S1 (Note 4)	Select input, bit 1.
10	CLKB3 (Note 3)	Buffered clock output, Bank B.
11	CLKB4 (Note 3)	Buffered clock output, Bank B.
12	GND	Ground.
13	V _{DD}	3.3 V supply.
14	CLKA3 (Note 3)	Buffered clock output, Bank A.
15	CLKA4 (Note 3)	Buffered clock output, Bank A.
16	CLKOUT (Note 3)	Buffered output, internal feedback on this pin.

2. Weak pulldown.
3. Weak pulldown on all outputs.
4. Weak pullup on these inputs.

NB2309A

Table 3. MAXIMUM RATINGS

Parameter	Min	Max	Unit
Supply Voltage to Ground Potential	-0.5	+7.0	V
DC Input Voltage (Except REF)	-0.5	$V_{DD} + 0.5$	V
DC Input Voltage (REF)	-0.5	7	V
Storage Temperature	-65	+150	°C
Maximum Soldering Temperature (10 sec)		260	°C
Junction Temperature		150	°C
Static Discharge Voltage (per MIL-STD-883, Method 3015)		>2000	V

Maximum ratings are those values beyond which device damage can occur. Maximum ratings applied to the device are individual stress limit values (not normal operating conditions) and are not valid simultaneously. If these limits are exceeded, device functional operation is not implied, damage may occur and reliability may be affected.

Table 4. OPERATING CONDITIONS FOR COMMERCIAL AND INDUSTRIAL TEMPERATURE DEVICES

Parameter	Description	Min	Max	Unit
V_{DD}	Supply Voltage	3.0	3.6	V
T_A	Operating Temperature (Ambient Temperature)	Commercial Industrial 0 -40	70 85	°C
C_L	Load Capacitance, below 100 MHz		30	pF
C_L	Load Capacitance, from 100 MHz to 133 MHz		10	pF
C_{IN}	Input Capacitance		7	pF

Table 5. ELECTRICAL CHARACTERISTICS FOR COMMERCIAL AND INDUSTRIAL TEMPERATURE DEVICES

Parameter	Description	Test Conditions	Min	Max	Unit
V_{IL}	Input LOW Voltage (Note 5)			0.8	V
V_{IH}	Input HIGH Voltage (Note 5)		2.0		V
I_{IL}	Input LOW Current	$V_{IN} = 0\text{ V}$		50.0	μA
I_{IH}	Input HIGH Current	$V_{IN} = V_{DD}$		100.0	μA
V_{OL}	Output LOW Voltage	$I_{OL} = 8\text{ mA} (-1)$ $I_{OL} = 12\text{ mA} (-1H)$		0.4	V
V_{OH}	Output HIGH Voltage	$I_{OH} = -8\text{ mA} (-1)$ $I_{OH} = -12\text{ mA} (-1H)$	2.4		V
I_{DD}	Supply Current (Commercial Temp)	Unloaded outputs at 66.67 MHz, Select inputs at V_{DD}		34	mA
I_{DD}	Supply Current (Industrial Temp)	Unloaded outputs at 100 MHz 66.67 MHz 33 MHz Select inputs at V_{DD} or GND, at Room Temp		50 34 19	mA

5. REF input has a threshold voltage of $V_{DD}/2$.

NB2309A

Table 6. SWITCHING CHARACTERISTICS (Commercial and Industrial) (Note 6)

Parameter	Description	Test Conditions	Min	Typ	Max	Unit
1/t ₁	Output Frequency	30 pF load 10 pF load	15 15		100 133.33	MHz
1/t ₁	Duty Cycle = (t ₂ / t ₁) * 100 (-1, -1H) (-1H)	Measured at 1.4 V, F _{OUT} = 66.67 MHz < 50 MHz	40 45	50 50	60 55	%
t ₃	Output Rise Time (-1, -1H) (-1H)	Measured between 0.8 V and 2.0 V			2.5 1.5	ns
t ₄	Output Fall Time	Measured between 2.0 V and 0.8 V			1.5	ns
t ₅	Output-to-Output Skew	All outputs equally loaded			250	ps
t ₆	Delay, REF Rising Edge to CLKOUT Rising Edge	Measured at V _{DD} /2		0	±350	ps
t ₇	Device-to-Device Skew	Measured at V _{DD} /2 on the CLKOUT pins of the device		0	700	ps
t ₈	Output Slew Rate	Measured between 0.8 V and 2.0 V using Test Circuit #2	1			V/ns
t _J	Cycle-to-Cycle Jitter	Measured at 66.67 MHz, loaded outputs			200	ps
t _{LOCK}	PLL Lock Time	Stable power supply, valid clock presented on REF pin			1.0	ms
t _{r_in}	REF Input Rise Time	Measured between 0.8 V to 2.0 V			1.0	ns
t _{f_in}	REF Input Rise Fall Time	Measured between 2.0 V to 0.8 V			1.0	ns

6. All parameters specified with loaded outputs and apply to both PLL-Mode and PLL-Bypass Mode.

NB2309A

Zero Delay and Skew Control

All outputs should be uniformly loaded to achieve Zero Delay between input and output. Since the CLKOUT pin is the internal feedback to the PLL, its relative loading can adjust the input-output delay.

For applications requiring zero input-output delay, all outputs, including CLKOUT, must be equally loaded. Even if CLKOUT is not used, it must have a capacitive load equal to that on other outputs, for obtaining zero-input-output delay.

SWITCHING WAVEFORMS

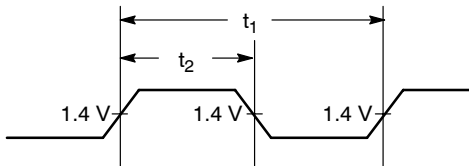

Figure 3. Duty Cycle Timing

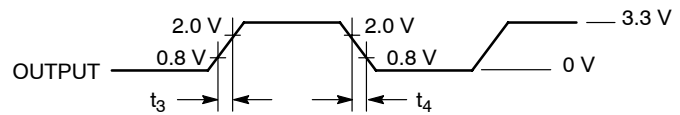

Figure 4. All Outputs Rise/Fall Time

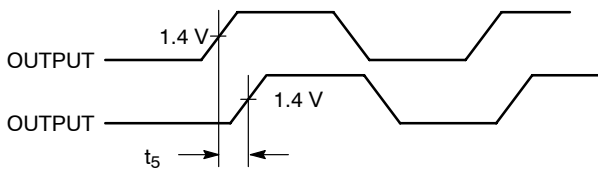

Figure 5. Output - Output Skew

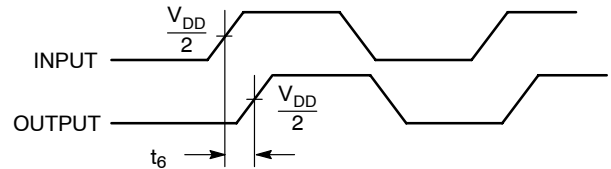

Figure 6. Input - Output Propagation Delay

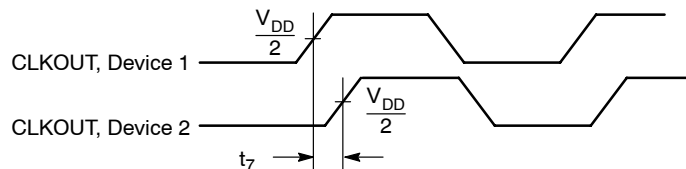

Figure 7. Device - Device Skew

TEST CIRCUITS

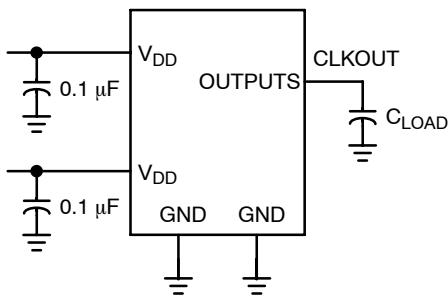

Figure 8. Test Circuit #1

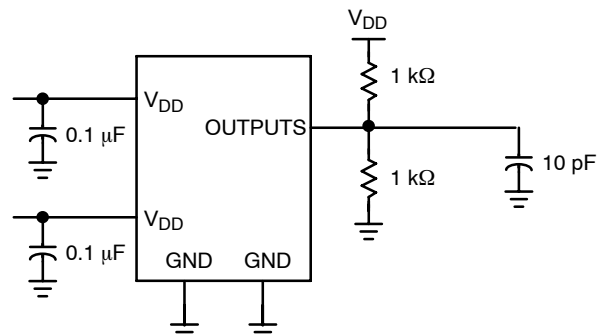

Figure 9. Test Circuit #2
For parameter t_8 (output slew rate) on -1H devices

NB2309A

ORDERING INFORMATION

Device	Marking	Operating Range	Package	Shipping [†]	Availability
NB2309AC1DG	2309AC1G	Commercial	SOIC-16 (Pb-Free)	48 Units / Rail	<i>Now</i>
NB2309AC1DR2G	2309AC1G	Commercial	SOIC-16 (Pb-Free)	2500 Tape & Reel	<i>Now</i>
NB2309AI1DG	2309AI1G	Industrial	SOIC-16 (Pb-Free)	48 Units / Rail	<i>Now</i>
NB2309AI1DR2G	2309AI1G	Industrial	SOIC-16 (Pb-Free)	2500 Tape & Reel	<i>Now</i>
NB2309AC1HDG	2309AC1HG	Commercial	SOIC-16 (Pb-Free)	48 Units / Rail	<i>Now</i>
NB2309AC1HDR2G	2309AC1HG	Commercial	SOIC-16 (Pb-Free)	2500 Tape & Reel	<i>Now</i>
NB2309AI1HDG	2309AI1HG	Industrial	SOIC-16 (Pb-Free)	48 Units / Rail	<i>Now</i>
NB2309AI1HDR2G	2309AI1HG	Industrial	SOIC-16 (Pb-Free)	2500 Tape & Reel	<i>Now</i>
NB2309AC1DTG	2309AC1	Commercial	TSSOP-16 (Pb-Free)	96 Units / Rail	<i>Now</i>
NB2309AC1DTR2G	2309AC1	Commercial	TSSOP-16 (Pb-Free)	2500 Tape & Reel	<i>Now</i>
NB2309AI1DTG	2309AI1	Industrial	TSSOP-16 (Pb-Free)	96 Units / Rail	<i>Now</i>
NB2309AI1DTR2G	2309AI1	Industrial	TSSOP-16 (Pb-Free)	2500 Tape & Reel	<i>Now</i>
NB2309AC1HDTG	2309AC1H	Commercial	TSSOP-16 (Pb-Free)	96 Units / Rail	<i>Now</i>
NB2309AC1HDTR2G	2309AC1H	Commercial	TSSOP-16 (Pb-Free)	2500 Tape & Reel	<i>Now</i>
NB2309AI1HDTG	2309AI1H	Industrial	TSSOP-16 (Pb-Free)	96 Units / Rail	<i>Now</i>
NB2309AI1HDTR2G	2309AI1H	Industrial	TSSOP-16 (Pb-Free)	2500 Tape & Reel	<i>Now</i>

[†]For information on tape and reel specifications, including part orientation and tape sizes, please refer to our Tape and Reel Packaging Specifications Brochure, BRD8011/D.

NB2309A

PACKAGE DIMENSIONS

TSSOP-16
CASE 948F-01
ISSUE A

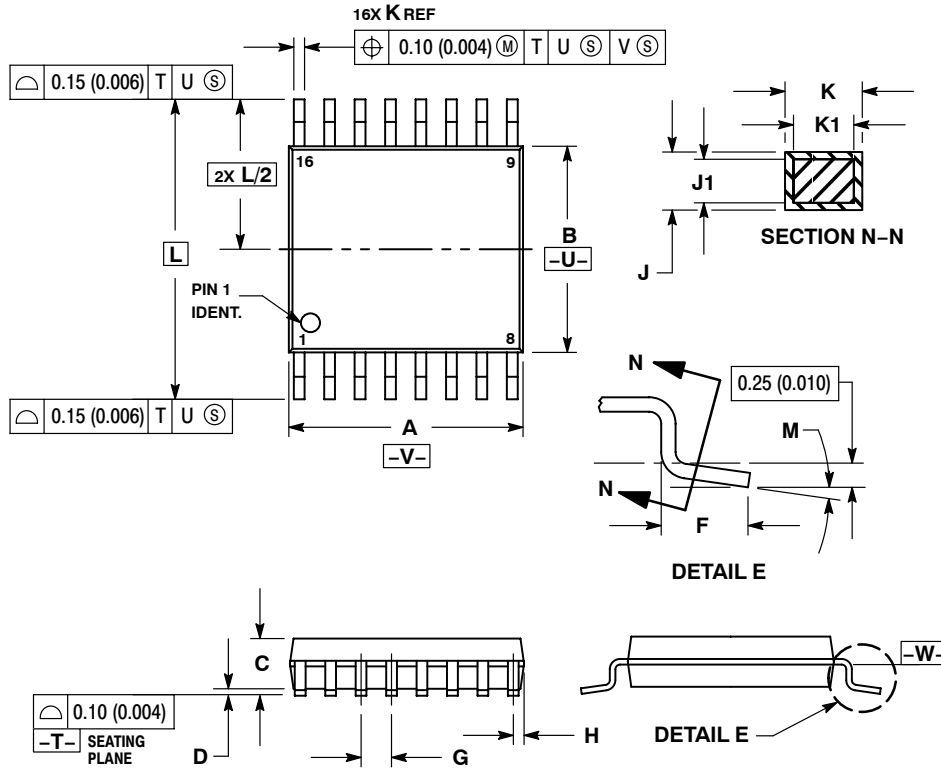

NOTES:

1. DIMENSIONING AND TOLERANCING PER ANSI Y14.5M, 1982.
2. CONTROLLING DIMENSION: MILLIMETER.
3. DIMENSION A DOES NOT INCLUDE MOLD FLASH, PROTRUSIONS OR GATE BURRS. MOLD FLASH OR GATE BURRS SHALL NOT EXCEED 0.15 (0.006) PER SIDE.
4. DIMENSION B DOES NOT INCLUDE INTERLEAD FLASH OR PROTRUSION. INTERLEAD FLASH OR PROTRUSION SHALL NOT EXCEED 0.25 (0.010) PER SIDE.
5. DIMENSION K DOES NOT INCLUDE DAMBAR PROTRUSION. ALLOWABLE DAMBAR PROTRUSION SHALL BE 0.08 (0.003) TOTAL IN EXCESS OF THE K DIMENSION AT MAXIMUM MATERIAL CONDITION.
6. TERMINAL NUMBERS ARE SHOWN FOR REFERENCE ONLY.
7. DIMENSION A AND B ARE TO BE DETERMINED AT DATUM PLANE -W-.

DIM	MILLIMETERS		INCHES	
	MIN	MAX	MIN	MAX
A	4.90	5.10	0.193	0.200
B	4.30	4.50	0.169	0.177
C	---	1.20	---	0.047
D	0.05	0.15	0.002	0.006
F	0.50	0.75	0.020	0.030
G	0.65 BSC		0.026 BSC	
H	0.18	0.28	0.007	0.011
J	0.09	0.20	0.004	0.008
J1	0.09	0.16	0.004	0.006
K	0.19	0.30	0.007	0.012
K1	0.19	0.25	0.007	0.010
L	6.40 BSC		0.252 BSC	
M	0°	8°	0°	8°

NB2309A

PACKAGE DIMENSIONS

SOIC-16
CASE 751B-05
ISSUE J

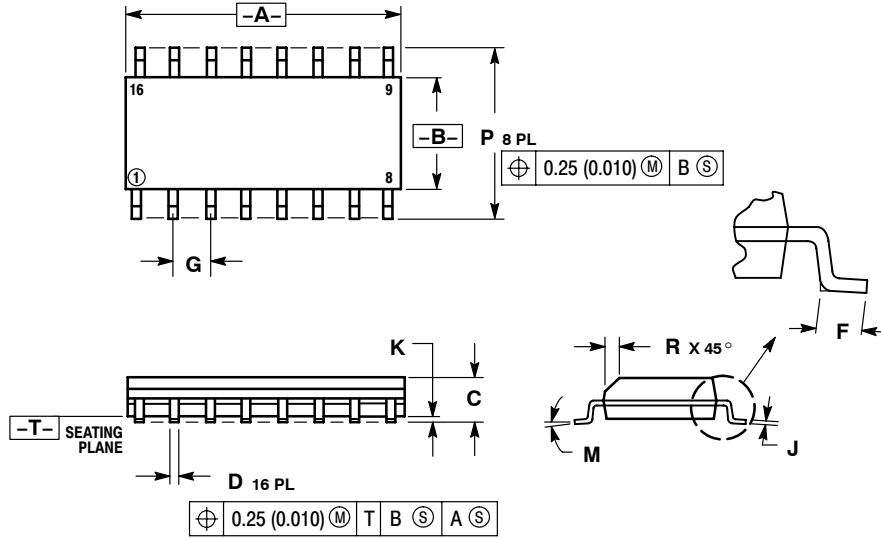

NOTES:

1. DIMENSIONING AND TOLERANCING PER ANSI Y14.5M, 1982.
2. CONTROLLING DIMENSION: MILLIMETER.
3. DIMENSIONS A AND B DO NOT INCLUDE MOLD PROTRUSION.
4. MAXIMUM MOLD PROTRUSION 0.15 (0.006) PER SIDE.
5. DIMENSION D DOES NOT INCLUDE DAMBAR PROTRUSION. ALLOWABLE DAMBAR PROTRUSION SHALL BE 0.127 (0.005) TOTAL IN EXCESS OF THE D DIMENSION AT MAXIMUM MATERIAL CONDITION.

DIM	MILLIMETERS		INCHES	
	MIN	MAX	MIN	MAX
A	9.80	10.00	0.386	0.393
B	3.80	4.00	0.150	0.157
C	1.35	1.75	0.054	0.068
D	0.35	0.49	0.014	0.019
F	0.40	1.25	0.016	0.049
G	1.27 BSC		0.050 BSC	
J	0.19	0.25	0.008	0.009
K	0.10	0.25	0.004	0.009
M	0° 7°		0° 7°	
P	5.80	6.20	0.229	0.244
R	0.25	0.50	0.010	0.019

Pentium is a registered trademark of Intel Corporation.
Licensed under US patent Nos 5,488,627, 6,646,463 and 5,631,920.

ON Semiconductor and are registered trademarks of Semiconductor Components Industries, LLC (SCILLC). SCILLC reserves the right to make changes without further notice to any products herein. SCILLC makes no warranty, representation or guarantee regarding the suitability of its products for any particular purpose, nor does SCILLC assume any liability arising out of the application or use of any product or circuit, and specifically disclaims any and all liability, including without limitation special, consequential or incidental damages. "Typical" parameters which may be provided in SCILLC data sheets and/or specifications can and do vary in different applications and actual performance may vary over time. All operating parameters, including "Typicals" must be validated for each customer application by customer's technical experts. SCILLC does not convey any license under its patent rights nor the rights of others. SCILLC products are not designed, intended, or authorized for use as components in systems intended for surgical implant into the body, or other applications intended to support or sustain life, or for any other application in which the failure of the SCILLC product could create a situation where personal injury or death may occur. Should Buyer purchase or use SCILLC products for any such unintended or unauthorized application, Buyer shall indemnify and hold SCILLC and its officers, employees, subsidiaries, affiliates, and distributors harmless against all claims, costs, damages, and expenses, and reasonable attorney fees arising out of, directly or indirectly, any claim of personal injury or death associated with such unintended or unauthorized use, even if such claim alleges that SCILLC was negligent regarding the design or manufacture of the part. SCILLC is an Equal Opportunity/Affirmative Action Employer. This literature is subject to all applicable copyright laws and is not for resale in any manner.

PUBLICATION ORDERING INFORMATION

LITERATURE FULFILLMENT:

Literature Distribution Center for ON Semiconductor
P.O. Box 5163, Denver, Colorado 80217 USA
Phone: 303-675-2175 or 800-344-3860 Toll Free USA/Canada
Fax: 303-675-2176 or 800-344-3867 Toll Free USA/Canada
Email: orderlit@onsemi.com

N. American Technical Support: 800-282-9855 Toll Free
USA/Canada
Europe, Middle East and Africa Technical Support:
Phone: 421 33 790 2910
Japan Customer Focus Center
Phone: 81-3-5773-3850

ON Semiconductor Website: www.onsemi.com

Order Literature: <http://www.onsemi.com/orderlit>

For additional information, please contact your local Sales Representative