



# HOA1884

## Transmissive Sensor

### FEATURES

- Choice of phototransistor or photodarlington output
- Side mount package
- Accurate position sensing
- 0.125 in.(3.18 mm) slot width



INFRA-75.TIF

### DESCRIPTION

The HOA1884 series consists of an infrared emitting diode facing an NPN silicon phototransistor (HOA1884- 011, - 012) or photodarlington (HOA1884- 013) encased in a black thermoplastic housing. Detector switching takes place whenever an opaque object passes through the slot between emitter and detector. The side mounting package is useful in applications in which the interruptive element is parallel to the mounting plane. Both emitter and detector have a 0.020 in.(.508 mm) x 0.040 in.(1.02 mm) vertical aperture. The HOA1884 series employs plastic molded components. For additional component information see SEP8506, SDP8406, and SDP8106.

Housing material is polyester. Housings are soluble in chlorinated hydrocarbons and ketones. Recommended cleaning agents are methanol and isopropanol.

### OUTLINE DIMENSIONS in inches (mm)

Tolerance 3 plc decimals ±0.010(0.25)  
2 plc decimals ±0.020(0.51)

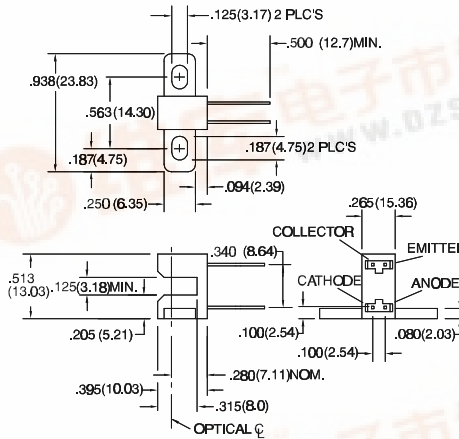

DIM\_054.cdr



# HOA1884

## Transmissive Sensor

### ELECTRICAL CHARACTERISTICS (25°C unless otherwise noted)

PARAMETER	SYMBOL	MIN	TYP	MAX	UNITS	TEST CONDITIONS
<b>IR EMITTER</b>						
Forward Voltage	$V_F$			1.6	V	$I_F=20\text{ mA}$
Reverse Leakage Current	$I_R$			10	$\mu\text{A}$	$V_R=3\text{ V}$
<b>DETECTOR</b>						
Collector-Emitter Breakdown Voltage HOA1884-011, -012 HOA1884-013	$V_{(BR)CEO}$	30 15			V	$I_C=100\text{ }\mu\text{A}$
Emitter-Collector Breakdown Voltage	$V_{(BR)ECO}$	5.0			V	$I_E=100\text{ }\mu\text{A}$
Collector Dark Current HOA1884-011, -012 HOA1884-013	$I_{CEO}$			100 250	nA	$V_{CE}=10\text{ V}$ $I_F=0$
<b>COUPLED CHARACTERISTICS</b>						
On-State Collector Current HOA1884-011 HOA1884-012 HOA1884-013	$I_{C(ON)}$	0.3 1.8 4.0			mA	$V_{CE}=5\text{ V}$ $I_F=20\text{ mA}$
Collector-Emitter Saturation Voltage HOA1884-011 HOA1884-012 HOA1884-013	$V_{CE(SAT)}$			0.4 0.4 1.1	V	$I_F=20\text{ mA}$ $I_C=40\text{ }\mu\text{A}$ $I_C=230\text{ }\mu\text{A}$ $I_C=500\text{ }\mu\text{A}$
Rise And Fall Time HOA1884-011, -012 HOA1884-013	$t_r, t_f$		15 75		$\mu\text{s}$	$V_{CC}=5\text{ V}$ , $I_C=1\text{ mA}$ $R_L=1000\text{ }\Omega$ $R_L=100\text{ }\Omega$

### ABSOLUTE MAXIMUM RATINGS

(25°C Free-Air Temperature unless otherwise noted)

Operating Temperature Range	-40°C to 85°C
Storage Temperature Range	-40°C to 85°C
Soldering Temperature (5 sec)	240°C

#### IR EMITTER

Power Dissipation	100 mW <sup>(1)</sup>
Reverse Voltage	3 V
Continuous Forward Current	50 mA

#### DETECTOR

	TRANS.	DARLINGTON
Collector-Emitter Voltage	30 V	15 V
Emitter-Collector Voltage	5 V	5 V
Power Dissipation	100 mW <sup>(1)</sup>	100 mW <sup>(1)</sup>
Collector DC Current	30 mA	30 mA

### SCHEMATIC

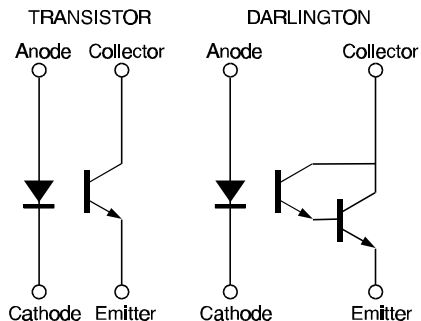

Honeywell reserves the right to make changes in order to improve design and supply the best products possible.

# Honeywell

# HOA1884

## Transmissive Sensor

Fig. 1 IRED Forward Bias Characteristics

gra\_092.ds4

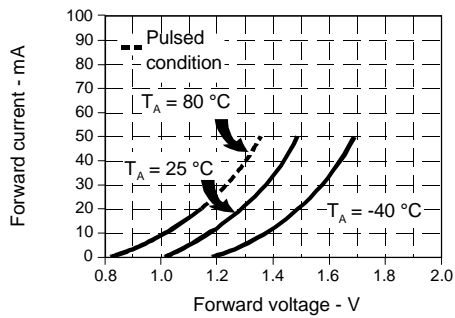

Fig. 2 Non-Saturated Switching Time vs Load Resistance

gra\_096.ds4

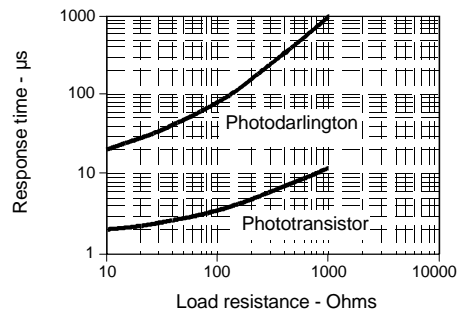

Fig. 3 Dark Current vs Temperature

gra\_301.cdr

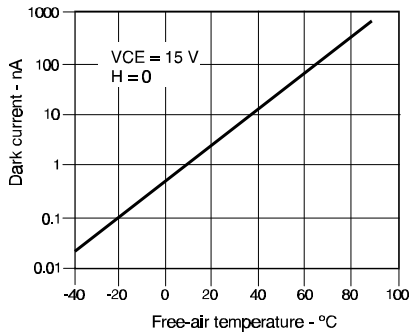
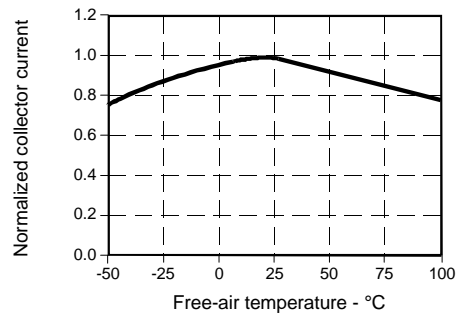

Fig. 4 Collector Current vs Ambient Temperature

gra\_095.ds4



All Performance Curves Show Typical Values

**HOA1884**  
Transmissive Sensor

---

Honeywell reserves the right to make changes in order to improve design and supply the best products possible.

**Honeywell**