

## Low Voltage Voice Switch Interface Circuit for Hands-free Operation in Telephone

### Description

The voice switch interface circuit U4087B is a linear integrated circuit for improvement of handsfree performance of U4090B system.

The U4087B provides an optimized interface to U4090B, the necessary level detectors and switching control for a properly operating speakerphone. The detection sensitivity and timing are externally controllable.

Additionally, the U4087B provides a back-ground noise monitor which makes the circuit insensitive to room noise.

The Block diagram shows level detectors, back ground noise monitor.

Due to low voltage operation it can be operated via power supply management of U4090B requiring 1.0 mA typ.

### Features

- Low voltage operation: 3.0 to 7.0 V
- Four point signal sensing
- Monitoring system for background noise level
- Case: SO 16
- Chip Disable for active/standby operation

### Benefits

- Fast channel switching allows quasi duplex operation
- Low current consumption

### Block Diagram

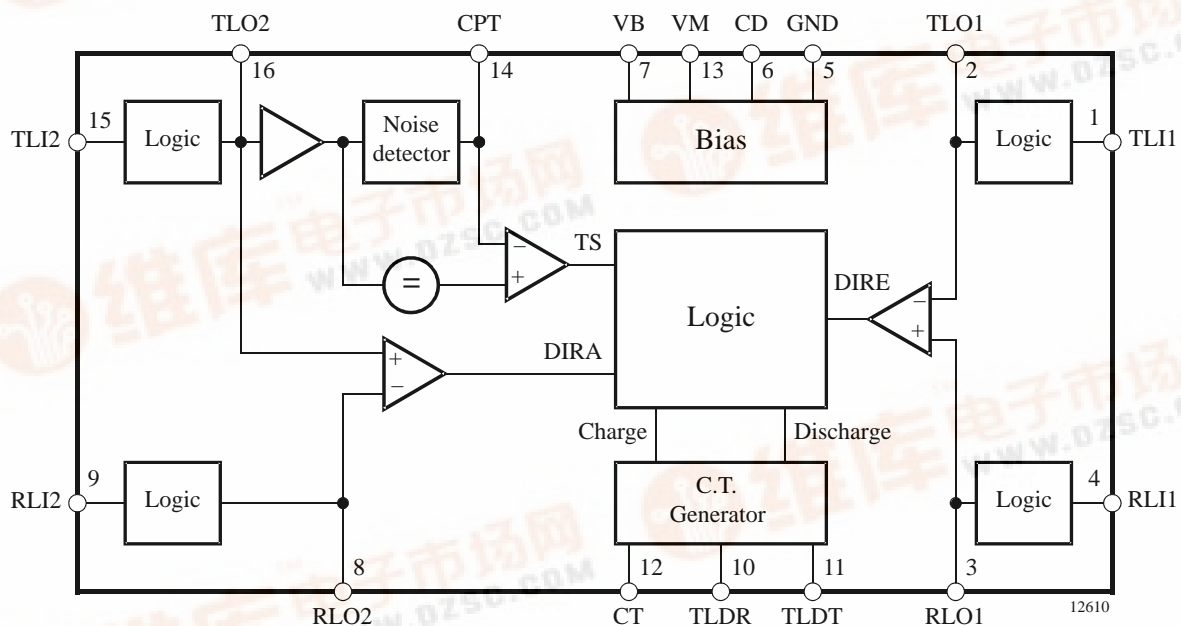

Figure 1. Block diagram with external circuit



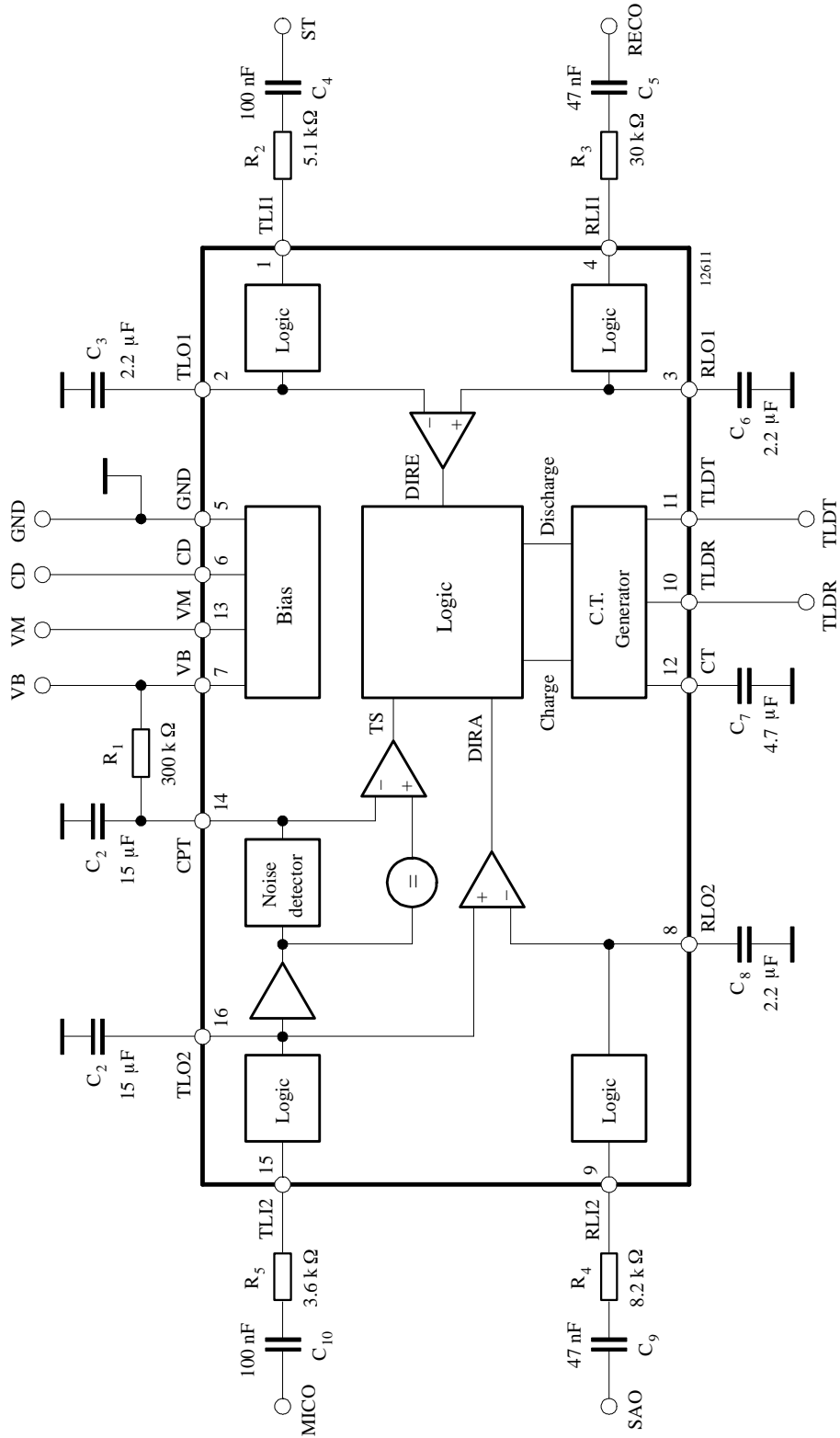

Figure 2. Application for hands-free operation

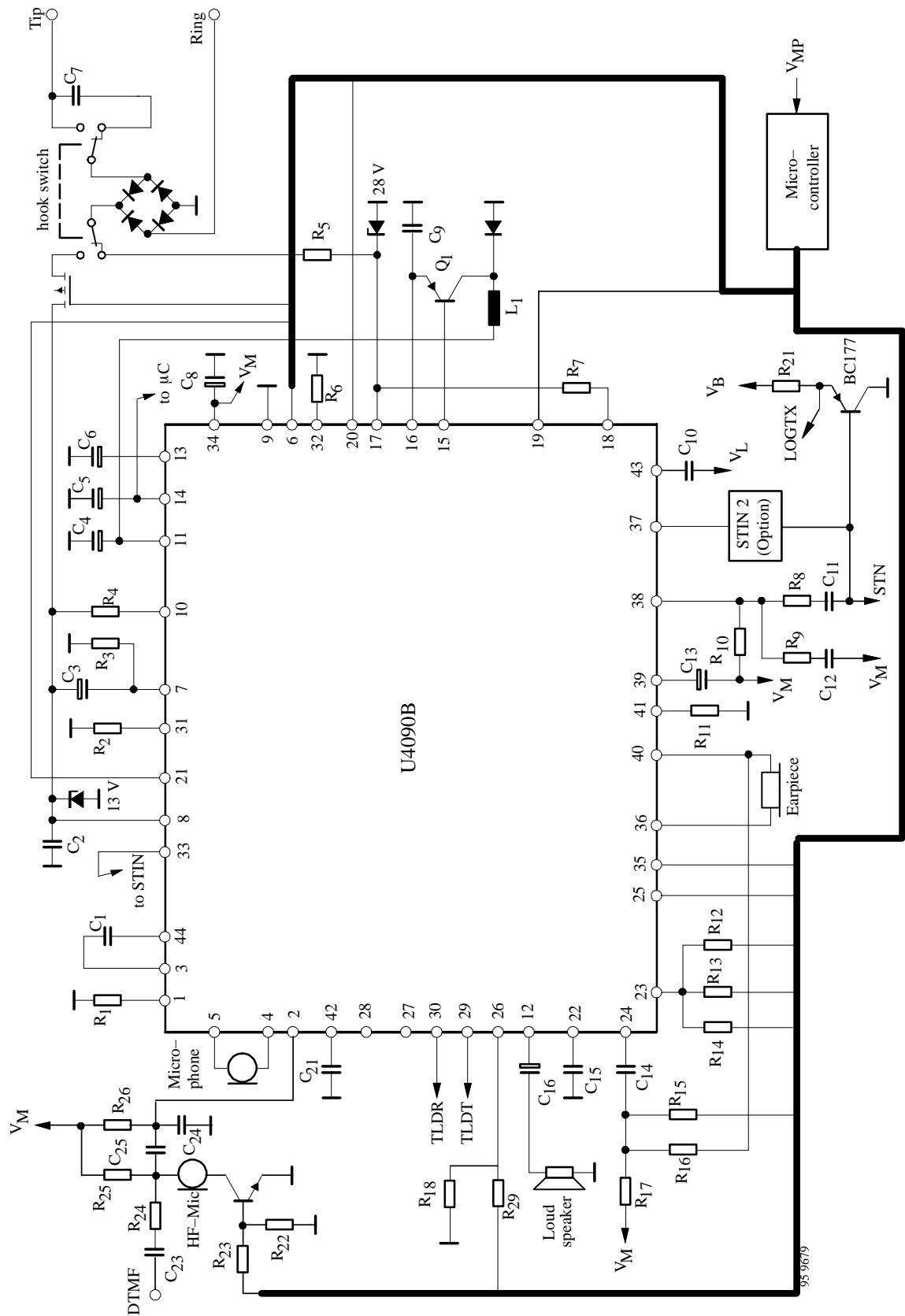

Figure 3. Application for handsfree operation

## Typical Value of External Components

C <sub>1</sub>	100 nF	R <sub>3</sub>	> 68 kΩ
C <sub>2</sub>	4.7 nF	R <sub>4</sub>	10 Ω
C <sub>3</sub>	10 μF	R <sub>5</sub>	1.5 kΩ
C <sub>4</sub>	220 μF	R <sub>6</sub>	62 kΩ
C <sub>5</sub>	47 μF	R <sub>7</sub>	680 kΩ
C <sub>6</sub>	470 μF	R <sub>8</sub>	22 kΩ
C <sub>7</sub>	820 nF	R <sub>9</sub>	330 Ω
C <sub>8</sub>	100 μF	R <sub>10</sub>	3 kΩ
C <sub>9</sub>	100 nF	R <sub>11</sub>	62 kΩ
C <sub>10</sub>	150 nF	R <sub>12</sub>	30 kΩ
C <sub>11</sub>	68 nF	R <sub>13</sub>	62 kΩ
C <sub>12</sub>	33 nF	R <sub>14</sub>	120 kΩ
C <sub>13</sub>	10 μF	R <sub>15</sub>	47 kΩ
C <sub>14</sub>	100 nF	R <sub>16</sub>	1 kΩ
C <sub>15</sub>	1 μF	R <sub>17</sub>	1.2 Ω
C <sub>16</sub>	47 μF	R <sub>18</sub>	30 kΩ
C <sub>17</sub>	10 μF	R <sub>19</sub>	6.8 kΩ
C <sub>18</sub>	10 μF	R <sub>20</sub>	6.8 kΩ
C <sub>19</sub>	68 nF	R <sub>21</sub>	15 kΩ
C <sub>20</sub>	68 nF	R <sub>22</sub>	330 kΩ
C <sub>21</sub>	1 μF	R <sub>23</sub>	220 kΩ
C <sub>22</sub>	100 nF	R <sub>24</sub>	68 kΩ
C <sub>23</sub>	6.8 nF	R <sub>25</sub>	2 kΩ
C <sub>24</sub>	10 nF	R <sub>26</sub>	3.3 kΩ
C <sub>25</sub>	100 nF	R <sub>27</sub>	18 kΩ
L <sub>1</sub>	2.2 mH	R <sub>28</sub>	2 kΩ
R <sub>1</sub>	27 kΩ	R <sub>29</sub>	
R <sub>2</sub>	20 kΩ	R <sub>31</sub>	56 kΩ

## Pin Description

Pin	Symbol	Function
1	TLI1	Transmit level detector input on the line side
2	TLO1	Transmit level detector output on the line side
3	RLO1	Receive level detector output on the line side
4	RLI1	Receive level detector input on the line side
5	GND	Ground
6	CD	Chip Disable A logic low (< 0.8 V) sets normal operation. A logic high (> 2.0 V) disables the IC to conserve power. Input impedance is nominally 90 k $\Omega$ .
7	V <sub>B</sub>	Supply voltage 2.8 to 7.0 V, approx. @ 1 mA
8	RLO2	Receive level detector output on the microphone/speaker side
9	RLI2	Receive level detector input on the microphone/speaker side
10	TLDR	Positive control output for U4090B
11	TLDT	Negative control output for U4090B
12	C <sub>T</sub>	Response time An RC at this pin sets the response time for the circuit to switch modes
13	V <sub>M</sub>	It is a system ac ground, supplied by U4090B, V <sub>M</sub> ~ V <sub>B</sub> /2
14	CPT	An RC at this pin sets the time constant for the transmit background monitor
15	TLI2	Transmit level detector input on the microphone/speaker side
16	TLO2	Transmit level detector output on the microphone/speaker side, and input to the transmit background monitor

## Absolute Maximum Ratings

Reference point Pin 1, T<sub>amb</sub> = 25°C, unless otherwise specified

Parameters	Symbol	Value	Unit
Supply voltage	Pin 7 V <sub>B</sub>	- 0.3 to + 12	V
Voltages:	Pin 6 Pin 13	- 0.3 to 6 - 0.3 to (V <sub>B</sub> + 0.3)	V
Storage temperature range	T <sub>stg</sub>	- 55 to + 150	°C
Junction temperature	T <sub>j</sub>	125	°C
Ambient temperature range	T <sub>amb</sub>	- 20 to + 60	°C
Power dissipation T <sub>amb</sub> = 60 °C	SO 16 P <sub>tot</sub>	750	mW
Maximum thermal resistance Junction ambient	SO 16 R <sub>thJA</sub>	110	K/W

## Operation Recommendation

Parameters	Test conditions / Pin	Symbol	Min.	Typ.	Max.	Unit
Supply voltage	Pin 7	V <sub>B</sub>	3.0	-	7.0	V
CD input Pin 6			0	-	V <sub>B</sub>	V
Ambient temperature range		T <sub>amb</sub>	- 20	-	+ 60	°C

## Electrical Characteristics

$T_{amb} = +25^{\circ}\text{C}$ ,  $V_S = 5.0\text{ V}$ ,  $CD \leq 0.8\text{ V}$ , unless otherwise specified

Parameters	Test conditions / Pin	Symbol	Min.	Typ.	Max.	Unit
<b>Power supply</b>						
Supply current	$V_B = 6.5\text{ V}$ , $CD = 0.8\text{ V}$ $V_B = 6.5\text{ V}$ , $CD = 2.0\text{ V}$	$I_B$		1.0 60.0	2.0 150.0	mA $\mu\text{A}$
CD input resistance	$V_B = V_{CD} = 6.5\text{ V}$	$R_{CD}$	50.0	90.0		$\text{k}\Omega$
CD input voltage	- High - Low	$V_{CDH}$ $V_{CDL}$	2.0 0.0		$V_B$ 0.8	V
<b>Attenuator control</b>						
$C_T$ voltage	Pin 12 – $V_M$ R mode Idle mode T mode	$V_{CT}$		+ 240.0 0.0 - 240.0		mV
$C_T$ source current	R mode	$I_{CTR}$	- 85.0	- 60.0	- 40.0	$\mu\text{A}$
$C_T$ sink current	T mode	$I_{CTT}$	+ 40.0	+ 60.0	+ 85.0	$\mu\text{A}$
$C_T$ idle current		$I_{CTS}$		0.0		$\mu\text{A}$
<b>Level detectors and background noise monitor</b>						
Source current	at RLO1, RLO2, TLO1, TLO2	$I_{LSO}$		- 2.0		mA
Sink current	at RLO1, RLO2, TLO1, TLO2	$I_{LSK}$		4.0		$\mu\text{A}$
CPT output resistance	$I_O = 1.0\text{ mA}$	$R_{CP}$		100		$\Omega$
CPT leakage current		$I_{CPLK}$		- 0.2		$\mu\text{A}$

## Ordering Information

Type	Package
U4087B-FP	SO16

**Dimensions in mm**

Package: SO16

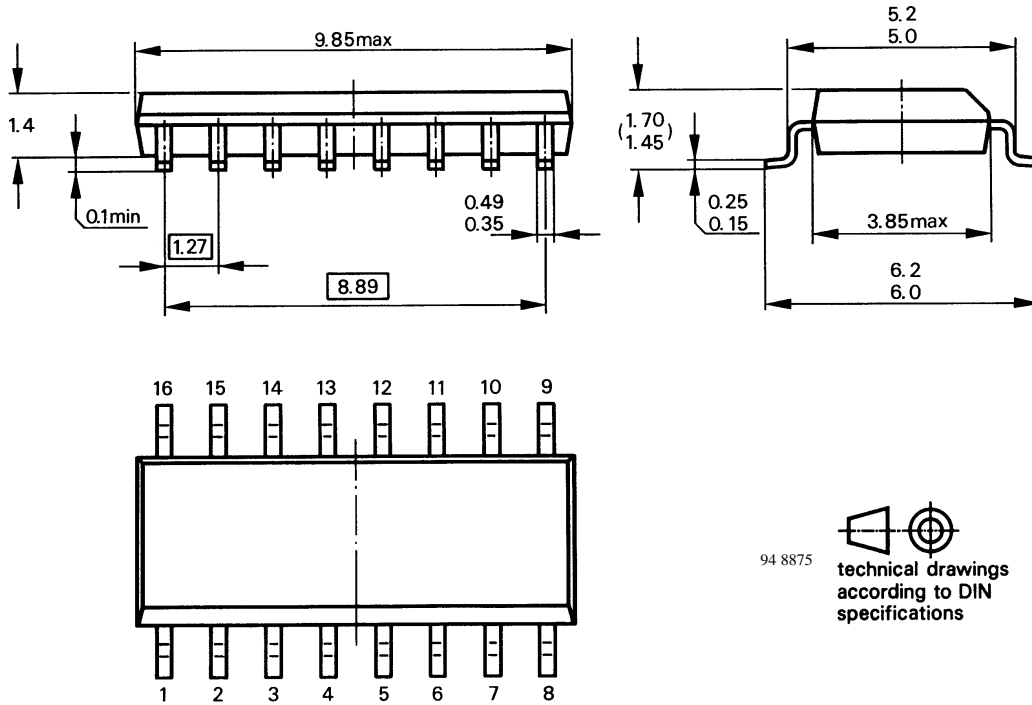

94 8875   
technical drawings  
according to DIN  
specifications

## Ozone Depleting Substances Policy Statement

It is the policy of **TEMIC TELEFUNKEN microelectronic GmbH** to

1. Meet all present and future national and international statutory requirements.
2. Regularly and continuously improve the performance of our products, processes, distribution and operating systems with respect to their impact on the health and safety of our employees and the public, as well as their impact on the environment.

It is particular concern to control or eliminate releases of those substances into the atmosphere which are known as ozone depleting substances (ODSs).

The Montreal Protocol (1987) and its London Amendments (1990) intend to severely restrict the use of ODSs and forbid their use within the next ten years. Various national and international initiatives are pressing for an earlier ban on these substances.

**TEMIC TELEFUNKEN microelectronic GmbH** semiconductor division has been able to use its policy of continuous improvements to eliminate the use of ODSs listed in the following documents.

1. Annex A, B and list of transitional substances of the Montreal Protocol and the London Amendments respectively
2. Class I and II ozone depleting substances in the Clean Air Act Amendments of 1990 by the Environmental Protection Agency (EPA) in the USA
3. Council Decision 88/540/EEC and 91/690/EEC Annex A, B and C (transitional substances) respectively.

**TEMIC** can certify that our semiconductors are not manufactured with ozone depleting substances and do not contain such substances.

**We reserve the right to make changes to improve technical design and may do so without further notice.**

Parameters can vary in different applications. All operating parameters must be validated for each customer application by the customer. Should the buyer use TEMIC products for any unintended or unauthorized application, the buyer shall indemnify TEMIC against all claims, costs, damages, and expenses, arising out of, directly or indirectly, any claim of personal damage, injury or death associated with such unintended or unauthorized use.

TEMIC TELEFUNKEN microelectronic GmbH, P.O.B. 3535, D-74025 Heilbronn, Germany  
Telephone: 49 (0)7131 67 2831, Fax number: 49 (0)7131 67 2423