

# Switch mode Power Supply S8VS

## Visible and Slim New Din Rail Power Supply

- Ultra-compact size (40 (W) × 95 (H) mm) (60-W Model)
- Displayed on 3-digit, 7-segment LED shows many status (voltage, current etc.) of power supply.
- Approved standards: UL508/60950, CSA C22.2 No.14/60950, EN50178 (=VDE0160), EN60950 (=VDE0806)



## Model Number Structure

### Model Number Legend

S8VS- □□□□□□  
          1   2   3

#### 1. Power Ratings

060: 60 W

090: 90 W

#### 2. Output voltage

24: 24 V

#### 3. Configuration

None: Standard Power Supply

A: With maintenance forecast monitor

B: With total run time monitor

## Ordering Information

Power ratings	Type	Output voltage	Output current	Model number
60 W	Standard type	24 V	2.5 A	S8VS-06024
	With maintenance forecast monitor type			S8VS-06024A
	With total run time monitor type			S8VS-06024B
90 W	Standard type		3.75 A	S8VS-09024
	With maintenance forecast monitor type			S8VS-09024A
	With total run time monitor type			S8VS-09024B

# Specifications

## ■ Ratings/Characteristics

Item	Power ratings Type	60 W			90 W		
		Standard	Maintenance forecast monitor	Total run time monitor	Standard	Maintenance forecast monitor	Total run time monitor
<b>Efficiency (typical)</b>		78% min.			80% min.		
<b>Input</b>	<b>Voltage</b>	100 to 240 VAC (85 to 264 VAC)					
	<b>Frequency</b>	50/60 Hz (47 to 450 Hz)					
	<b>Current</b>	<b>100 V input</b>	1.7 A		2.3 A		
		<b>200 V input</b>	1.0 A		1.4 A		
	<b>Power factor correction</b>	Conforms to EN61000-3-2 A-14					
	<b>Leakage current</b>	<b>100 V input</b>	0.5 mA max.				
		<b>200 V input</b>	1.0 mA max.				
<b>Inrush current (See note 1.)</b>	<b>100 V input</b>	25 A max.					
	<b>200 V input</b>	50 A max.					
<b>Output</b>	<b>Voltage adjustment range</b>	-10% to 15% (with V.ADJ)					
	<b>Ripple</b>	2.0% (p-p) max. (at rated input/output voltage)					
	<b>Input variation influence</b>	0.5% max. (at 85 to 264 VAC input, 100% load)					
	<b>Load variation influence (rated input voltage)</b>	1.5% max. (with rated input, 0 to 100% load)					
	<b>Temperature variation influence</b>	0.05%/°C max.					
	<b>Start up time (See note 1.)</b>	1,000 ms max.		500 ms max.	1,000 ms max.		500 ms max.
		(at rated input/output voltage)					
<b>Hold time (See note 1.)</b>	20 ms min. (at rated input/output voltage)						
<b>Additional function</b>	<b>Overload protection (See note 1.)</b>	105% to 160% of rated load current, inverted L drop, intermittent, automatic reset					
	<b>Overvoltage protection (See note 1.)</b>	Yes					
	<b>Output voltage indication (See note 2.)</b>	No	Yes (selectable) (See note 3.)		No	Yes (selectable) (See note 3.)	
	<b>Output load indication (See note 2.)</b>	No	Yes (selectable) (See note 4.)		No	Yes (selectable) (See note 4.)	
	<b>Peak-hold load indication (See note 2.)</b>	No	Yes (selectable) (See note 5.)		No	Yes (selectable) (See note 5.)	
	<b>Maintenance forecast monitor indication (See note 2.)</b>	No	Yes (selectable)		No	Yes (selectable)	
		No				Yes (open collector output), 30 VDC max., 50 mA max.	
	<b>Total run time monitor indication (See note 2.)</b>	No	Yes (selectable)		No	Yes (selectable)	
	<b>Total run time monitor output</b>	No				Yes (open collector output), 30 VDC max., 50 mA max.	
	<b>Undervoltage alarm indication (See note 2.)</b>	No	Yes (selectable)		No	Yes (selectable)	
	<b>Undervoltage alarm output terminals</b>	No				Yes (open collector output), 30 VDC max., 50 mA max.	
	<b>Parallel operation</b>	No					
	<b>Series operation</b>	Yes (with external diode)					
	<b>Other</b>	<b>Ambient temperature</b>	Operating: Refer to the derating curve in <i>Engineering Data</i> . (with no icing or condensation) Storage: -25 to 65°C				
<b>Ambient humidity</b>		Operating: 25% to 85%; Storage: 25% to 90%					
<b>Dielectric strength</b>		3.0 kVAC for 1 min. (between all inputs and outputs/ alarm outputs; detection current: 20 mA)					
		2.0 kVAC for 1 min. (between all inputs and GR terminals; detection current: 20 mA)					
		1.0 kVAC for 1 min. (between all outputs/ alarm outputs and GR terminals; detection current: 20 mA)					
<b>Insulation resistance</b>		500 VAC for 1 min. (between all outputs and alarm outputs; detection current: 20 mA)					
		100 MΩ min. (between all outputs/ alarm outputs and all inputs/ GR terminals) at 500 VDC					
<b>Vibration resistance</b>		10 to 55 Hz, 0.375-mm single amplitude for 2 h each in X, Y, and Z directions					
<b>Shock resistance</b>		150 m/s <sup>2</sup> , 3 times each in ±X, ±Y, and ±Z directions					
<b>Output indicator</b>		Yes (color: green)					
<b>Electromagnetic interference</b>		Conforms to FCC Class A, EN50081-2					
<b>EMI</b>	Conforms to EN50081-2						
<b>Approved standards</b>	UL: UL508 (Listing; Class 2: Per UL1310), UL60950 cUL: CSA C22.2 No.14, No.60950 (Class 2) EN/VDE: EN50178 (=VDE0160), EN60950 (=VDE0806)			UL: UL508 (Listing), UL60950 cUL: CSA C22.2 No.14, No.60950 EN/VDE: EN50178 (=VDE0160), EN60950 (=VDE0806)			
	330 g max.			490 g max.			

**Note:** 1. Refer to the *Engineering Data* section on page 59 for details.

2. Displayed on 7-segment LED.

3. Resolution of output voltage indication: 0.1 V, Precision of output voltage indication: ±2% (±1 digit for output voltage value)

4. Resolution of output load indication: 0.1 A, Precision of output load indication: ±5% (±1 digit for output load value)

5. Resolution of Peak-hold load indication: 0.1 A, Precision of Peak-hold load indication: ±5% (±1 digit for output load value), width of Peak-hold load indication: 10 ms

# Connections

## ■ Block Diagram

**S8VS-06024 (60 W)**  
**S8VS-06024A (60 W)**  
**S8VS-06024B (60 W)**

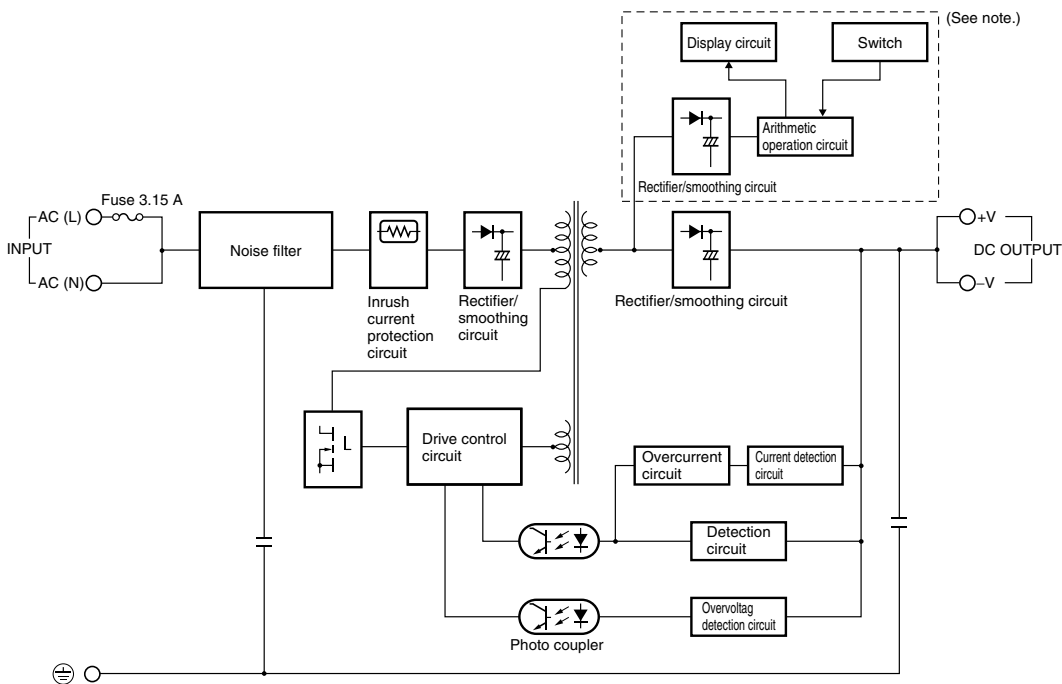

**Note:** The circuits within the dotted line are for the S8VS-06024□ Model only.

**S8VS-09024 (90 W)**  
**S8VS-09024A (90 W)**  
**S8VS-09024B (90 W)**

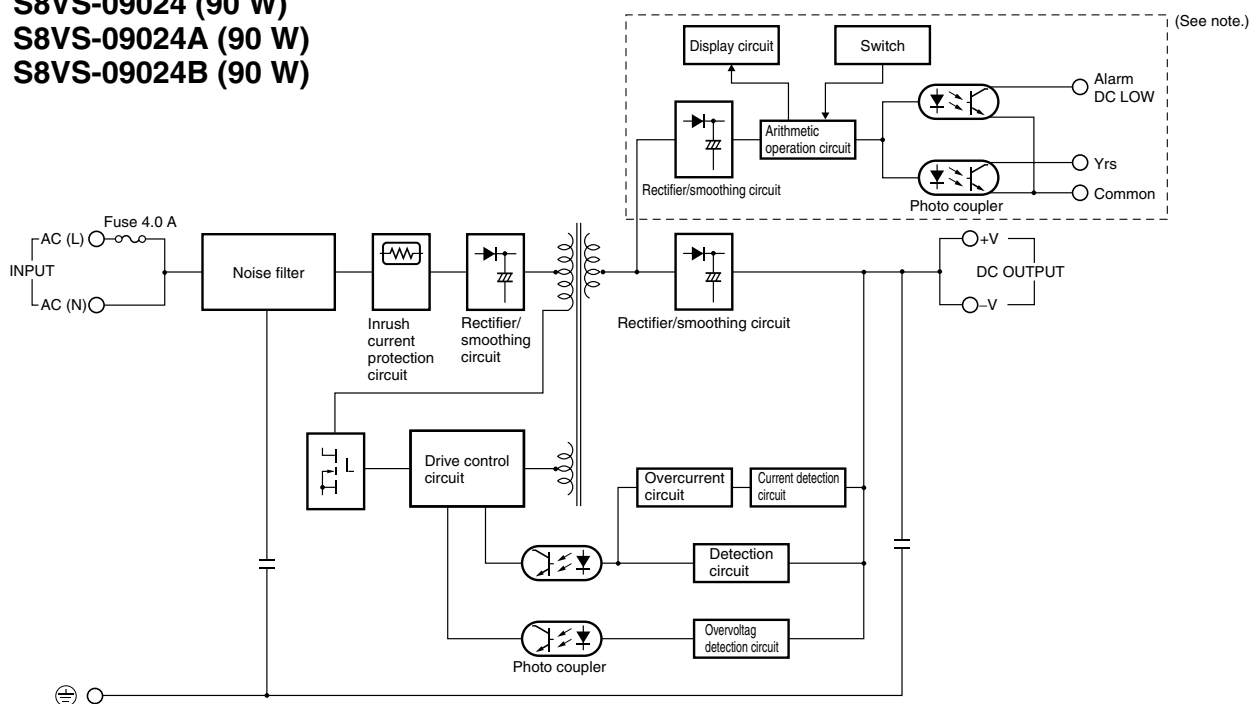

**Note:** The circuits within the dotted line are for the S8VS-09024□ Model only.

## ■ Installation

### 60-W Model

#### S8VS-06024

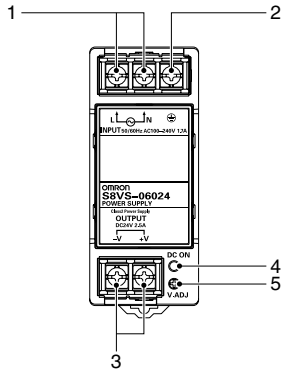

#### S8VS-06024□

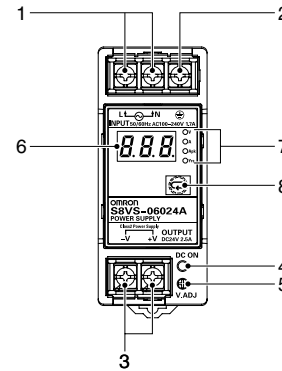

### 90-W Model

#### S8VS-09024

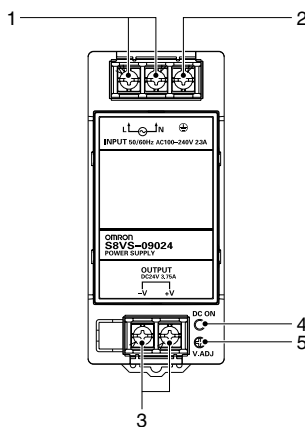

#### S8VS-09024□

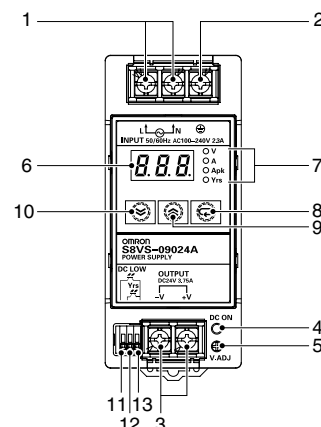

No.	Name	Function
1	AC Input terminals (L), (N)	Connect the input lines to these terminals. (See note 1.)
2	Ground terminals (GR)	Connect the ground line to this terminal.
3	DC Output terminals (-V), (+V)	Connect the load lines to these terminals.
4	Output indicator (DC ON: Green)	Lights while a direct current (DC) output is ON.
5	Output voltage adjuster (V.ADJ)	Use to adjust the voltage.
6	Main display (See note 2.)	Indicates the measurement or set value.
7	Operation indicator (See note 2.)	V Lights up when the output voltage is indicated. Blinks during setup of undervoltage alarm value.
		A Lights up during indication of output current.
		Apk Lights up during indication of peak hold current.
		Yrs Lights up during indication of maintenance forecast monitor. Blinks during setup of maintenance forecast monitor setting. (S8VS-0□024A)
	Kh Lights up during indication of total run time monitor. Blinks during setup of total run time monitor. (S8VS-0□024B)	

No.	Name	Function
8	Mode Key (See note 2.)	Use the Mode Key to change the indicated parameter or reset the peak hold current value.
9	Up Key (See note 3.)	Use the Up Key to change to the setting mode or to increase the set value.
10	Down Key (See note 3.)	Use the Down Key to change to the setting mode or to decrease the set value.
11	Alarm output terminal	Undervoltage alarm output terminal (DC LOW) (See note 3.) Outputs when a drop in the output voltage is detected. (at voltage drop: OFF)
12	Maintenance forecast monitor terminal (Yrs) (S8VS-09024A) Total run time monitor output terminal (Kh) (S8VS-09024B) (See note 3.)	Outputs when the maintenance forecast has reached the set value.
13	Common terminal for alarm output (See note 3.)	Terminal (emitter) shared for alarm outputs (11) and (12).

**Note:** 1. The fuse is located on the (L) side.

2. S8VS-□□□24□ only.

3. S8VS-09024□ Model only.

# Engineering Data

## Derating Curve

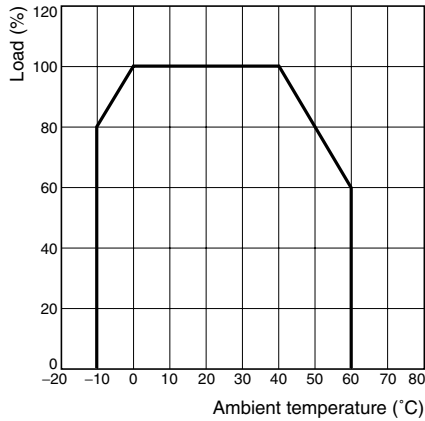

## Installation

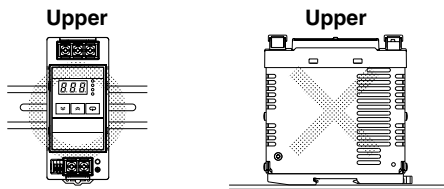

Standard mounting

Face-up mounting

- Note:**
1. Use standard mounting only. Using any other mounting method will prevent proper heat dissipation and may result in deterioration or damage of internal elements. Or, the remaining service life notice function cannot work properly.
  2. If there is a derating problem, use forced air-cooling. The ambient temperature is specified for a point 50 mm below the power supply.

## Overload Protection

The Power Supply is provided with an overload protection function that protects the load and the power supply from possible damage by overcurrent. When the output current rises above 105% min. of the rated current, the protection function is triggered, decreasing the output voltage. When the output current falls within the rated range, the overload protection function is automatically cleared.

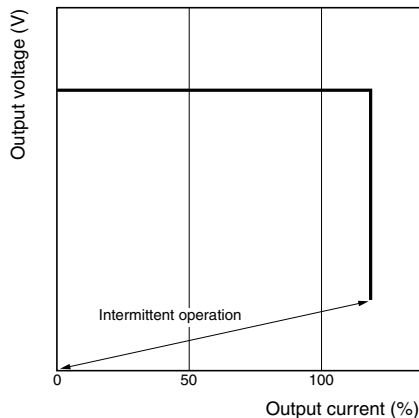

**Note:** Do not allow the short-circuited or overcurrent state to continue for more than 20 s, otherwise internal elements may deteriorate or be destroyed.

## Overvoltage Protection

The Power Supply is provided with an overvoltage protection function that protects the load and the Power Supply from possible damage by overvoltage. When an excessive voltage is output, the output voltage is shut OFF. Reset the Power Supply by turning it OFF for at least three minutes and then turning it back ON again.

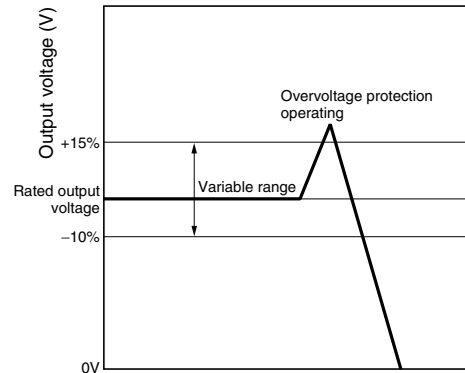

**Note:** Do not turn ON the power again until the cause of the overvoltage has been removed.

## Inrush Current, Start Up Time, Hold Time

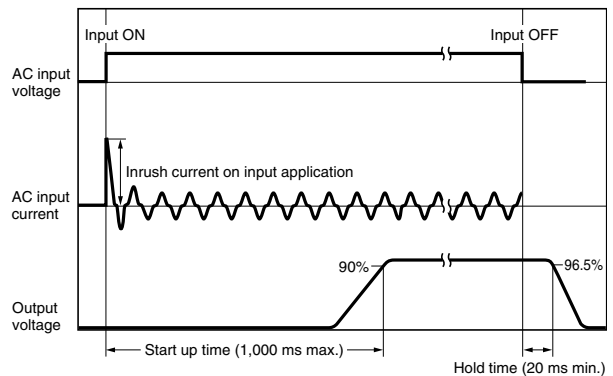

## ■ Undervoltage Alarm Function (Indication and Output)

When output voltage drop is detected, an alarm (RD) and lowest output voltage value are indicated alternately. The preset value of detection voltage can be changed in the setting mode. (S8VS-06024□: The value of detection voltage is fixed at 20V)

Further, the alarm is output from the transistor ((11) DC LOW) to an external device with the S8VS-09024A/B. (Upon output voltage alarm: OFF; with no continuity across (11) and (13))

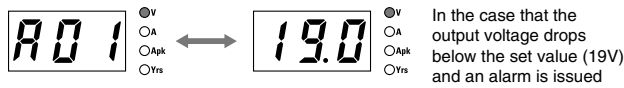

- Note:**
1. Operation begins after about two seconds since the AC power is supplied.
  2. The alarm is not indicated in the setting mode.
  3. Press the ((8) Mode Key) after the output voltage is restored, to reset alarm indication.
  4. The undervoltage alarm function monitors the output terminal voltage of the power supply unit. To check the voltage accurately, measure the voltage at the load end.

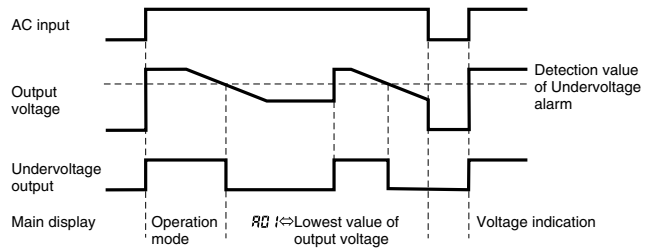

**Note:** Operation begins after about three seconds since the AC power is supplied.

## Engineering Data (S8VS-□□□24□ Only)

### ■ Mode Change

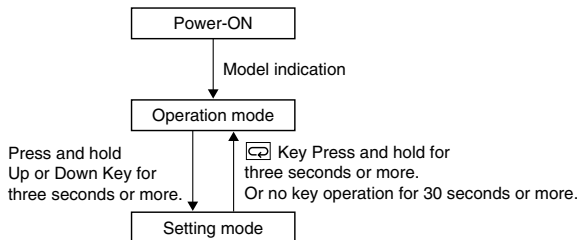

**Note:** No setting mode is provided for the S8VS-06024□.

### ■ Operation Mode

Various states of the power supply unit are indicated.

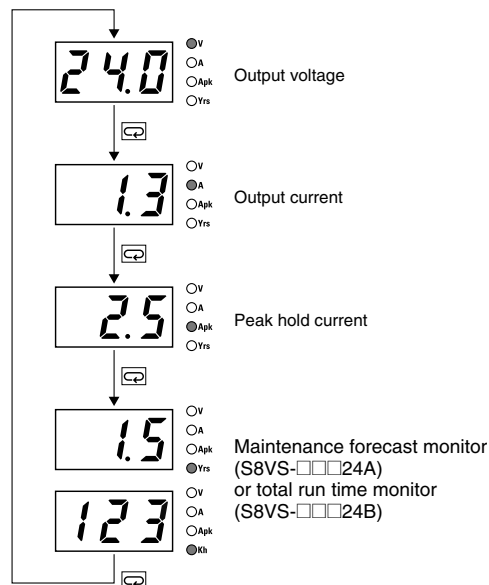

**Note:** The output voltage will be displayed when the power supply is first turned on after it is received from the factory. Thereafter, the output voltage will be indicated in the same display when shutting down.

## Setting Mode (Except for S8VS-06024□)

Set various parameters of the power supply unit.

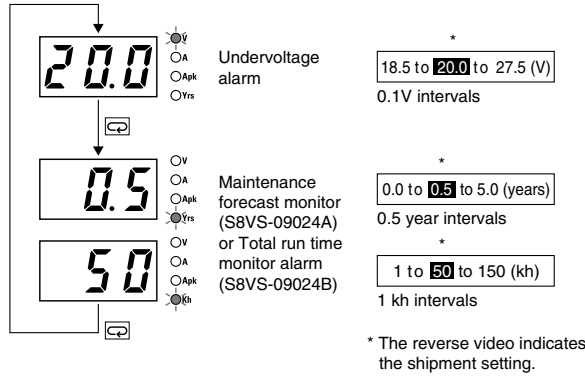

- Note:**
1. Press and hold the (9) Up Key or (10) Down Key for two seconds or more to increase or decrease the value rapidly.
  2. The S8VS-06024□ is not provided with the setting mode and its parameters are fixed at the shipment setting.

## Peak Hold Current Reset

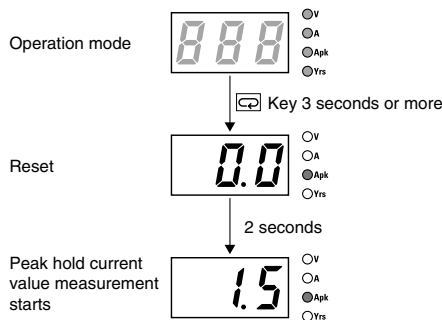

**Note:** The peak hold current value is not reset in the setting mode.

## Self-Diagnostics Function

(6) Main display	Description	Output state	Restoration method	Setting after restoration
---	Noise detected in voltage or current	No change	Automatic restoration	No change
Hot	Overheated	(12) OFF	Automatic restoration	No change
E01	Undervoltage alarm set value memory error	(11) OFF	Press and hold the (9) Up Key or (10) Down Key for three seconds and check the set value of the corresponding point. The set value must return to the shipment setting	Shipment setting or value set in the setting mode again
E02	Memory error of alarm set value of maintenance forecast monitor or total run time monitor	(12) OFF		
E03	Other memory error	(11) (12) OFF	Turn the AC input off then on again. If the product is not reset, contact the dealer.	No change

- Note:**
1. External noise is probable as a cause of “---”, “E01”, “E02” and “E03” errors.
  2. Operation out of the derating curve area, ventilation error, and incorrect mounting direction are probable as a cause of “Hot” error.
  3. If the “Hot” error state continues for about three hours, the maintenance forecast monitor function (S8VS-□□□24A only) becomes invalid. The indication for maintenance forecast monitor remains as “Hot” even after the overheat condition is removed, and the Yrs output (12) remains OFF (with no continuity across (12) and (13)). Replace the power supply if this condition occurs even if the output is correct, as internal parts may be deteriorated.
  4. The “Hot” error detection function is only for the S8VS-□□□24A.

## Total Run Time Monitor Indication and Alarm Output (S8VS-□□□24B)

The cumulative running hours of the power supply unit are monitored as total run time. When the total run time reaches the predetermined alarm set value, an alarm (R02) and the total run time monitor are indicated alternately with an output issued from the transistor ((12) Kh) to an external device. (The output is turned off when the total run time reaches the alarm set value; with no continuity across (12) and (13).)

The alarm set value can be changed in the setting mode.



- Note:**
1. The total run time cannot be reset. To reset the alarm, increase the alarm set value beyond the value indicated as total run time. Ex.) If a customer decided to change the load at 5,000 hours, when they turn the unit again the timing will start at 5,000 hours and on.
  2. The alarm function (setting, indication, and output) is not provided for S8VS-06024B.

## ■ Undervoltage Alarm Indication

This indicator lights when the output voltage is insufficient.

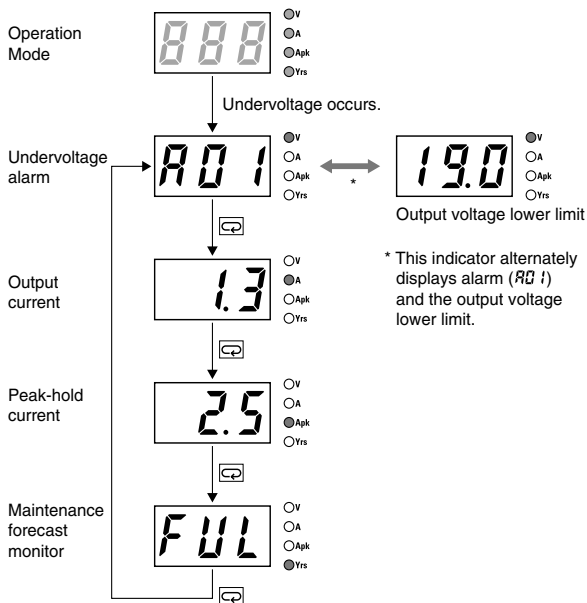

**Note:** The display changes to the output voltage display when the voltage is restored to the set value or higher.

## ■ Multiple Alarms

When two or more different alarms occur at the same time

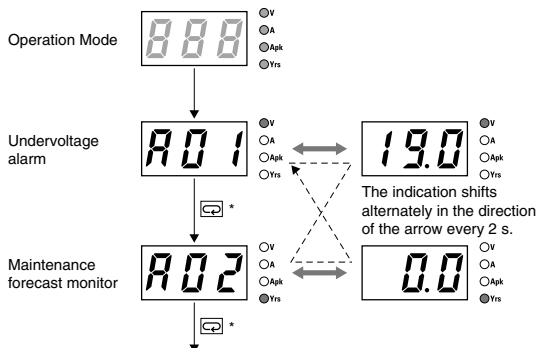

\* When undervoltage alarm is indicated: Press [ ] → output load indication  
 When the maintenance forecast monitor or overheat alarm is indicated:  
 Press [ ] → undervoltage alarm indication

## ■ Maintenance Forecast

Displays when the maintenance forecast has reached the set value.

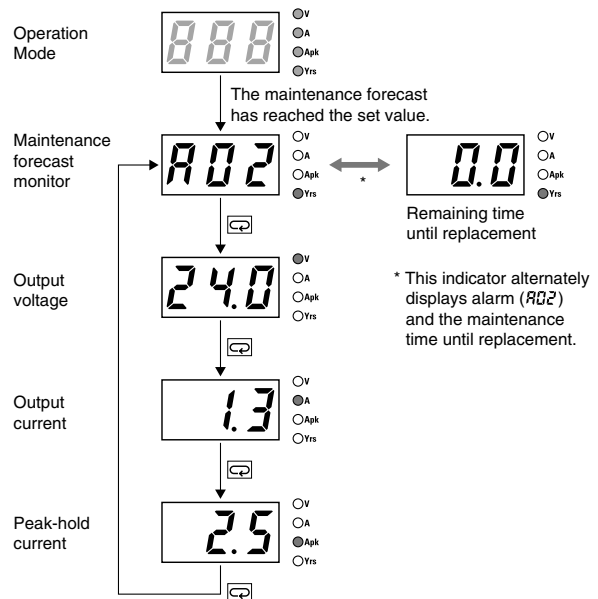

## ■ Indication and Output

When the product is purchased, "FUL" will be indicated. As electrolytic capacitors deteriorate, indication changes to "HLF". After the remaining time to maintenance is reduced to two years, indication automatically changes to a value, which decreases from "1.5" to "1.0" to "0.5" to "0" (year) as the running hours increase.

If the maintenance forecast monitor setting is set to a value larger than two years, value indication automatically begins after the remaining time to maintenance is reduced to the set years.

If the remaining time becomes smaller than setting L (which can be set arbitrarily between 0 and 5.0 years), an alarm (AO2) and the remaining time are indicated alternately.

With the S8VS-09024A, an output is given to an external device from a transistor ((12) Yrs) to notify of the replacement timing, together with indication. (The output is turned off after the replacement timing is reached; with no continuity across (12) and (13).)



- Note:**
- The remaining time to maintenance is based on continuous operation, not including the time when the power supply is turned off, and so may take longer to reach than the actual time indicated.
  - Until the power supply has been turned for about one month in total, indication is fixed at "FUL" to estimate the extent of deterioration, while the output remains turned on (with continuity across (12) and (13)).





# Dimensions

Note: All units are in millimeters unless otherwise indicated.

**S8VS-06024 (60 W)**  
**S8VS-06024A (60 W)**  
**S8VS-06024B (60 W)**

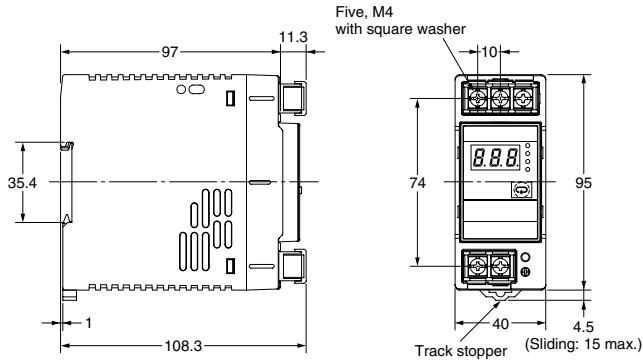

Note: The photo is the S8VS-06024A Model.

**S8VS-09024 (90 W)**  
**S8VS-09024A (90 W)**  
**S8VS-09024B (90 W)**

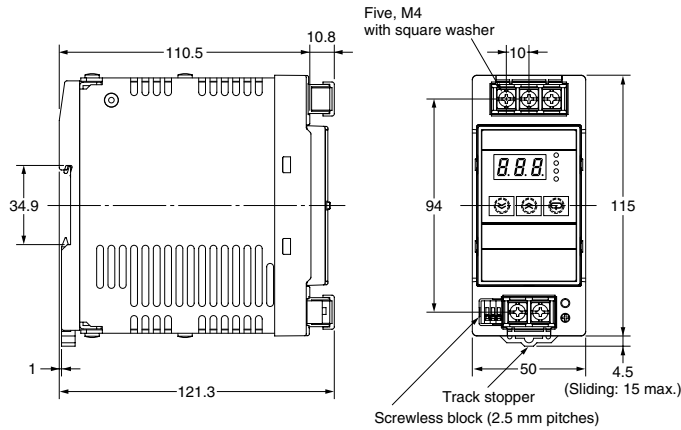

Note: The photo is the S8VS-09024A Model.

## ■ DIN Track (Order Separately)

Note: All units are in millimeters unless otherwise indicated.

### Mounting Track (Material: Aluminum)

**PFP-100N**  
**PFP-50N**

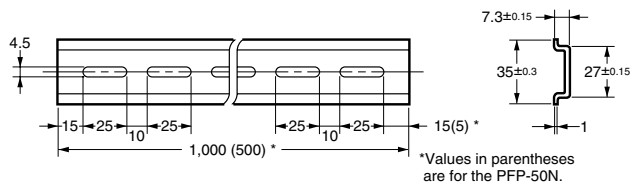
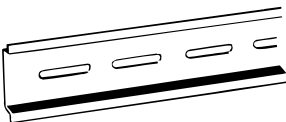

### Mounting Track (Material: Aluminum)

**PFP-100N2**

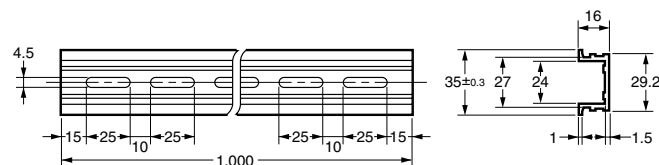
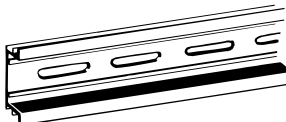

# Precautions

## ⚠ Caution

Do not disassemble the product or touch internal parts. Electric shock may be caused.

Do not touch the product during power-on, and immediately after poweroff. Hot surface may cause heat injury.

Tighten the terminal screw with torque 1.08 N·m. A loose screw may cause fire.

Install the terminal cover. Electric shock may be caused if not installed.

## Mounting

Be sure to allow convection in the atmosphere around devices when mounting. Do not use in locations where the ambient temperature exceeds the range of the derating curve.

When cutting out holes for mounting, make sure that cuttings do not enter the interior of the products.

Before turning the Power Supply ON, be sure to remove sheets that were used as covers during mounting, and make sure that heat release is not obstructed.

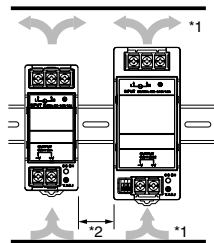

\*1. Convection of air  
\*2. 20 mm min.

## Wiring

Ground the product (GR) completely. Failure to do so could cause electric shock or malfunction.

Ensure that input and output terminals are wired correctly.

Do not apply more than 100N force to the terminal block when tightening it.

Be sure to remove the sheet covering the product for machining before power-on.

## Recommended Wire Type

Model	Recommended wire size
S8VS-06024□	AWG14 to 20 (Cross section 0.517 to 2.081mm <sup>2</sup> )
S8VS-09024□	AWG14 to 18 (Cross section 0.823 to 2.081mm <sup>2</sup> ) Alarm output terminal: AWG22 to 28 (Cross section 0.081 to 0.326mm <sup>2</sup> )

## Installation Environment

Do not use the Power Supply in locations subject to shocks or vibrations. In particular, install the Power Supply as far away as possible from contactors or other devices that are a vibration source.

Install the Power Supply well away from any sources of strong, high-frequency noise.

## Operating and Storage Environments

Do not use or store the Power Supply in the following locations. Doing so may result in failure, malfunction, or deterioration of performance characteristics.

- Do not use in locations subject to direct sunlight.
- Do not use in locations where the ambient temperature exceeds the range of the derating curve.
- Do not use in locations where the humidity is outside the range 25% to 85%, or locations subject to condensation due to sudden temperature changes.
- Do not store in locations where the ambient temperature is outside the range -25 to 65°C or where the humidity is outside the range 25% to 90%.
- Do not use locations where liquids, foreign matter, corrosive gases, or flammable gases may enter the interior of products.

## S8VS-□□□24A Model Only

Satisfy the following conditions when storing the Power Supply for long periods of time to maintain its remaining service life function.

- When storing for more than three months, store within an ambient temperature range of -25 to +30°C and the humidity range of 25 to 70%.

## Periodic Inspection (S8VS-09024A Model Only)

Under general operating conditions, the remaining service life function starts to work from several to ten and several years after start of use. When the Power Supply is used for long periods of time, periodically follow the procedure below to check that the remaining service life function ((12)Yrs) is working properly.

1. Set to the Power Supply to the Run Mode.
2. Make sure that output ((12)Yrs) is ON (electrical continuity across terminals (12) and (13)).
3. In the Run Mode, hold down the Down Key (10) and the Mode Key (8) for at least three seconds at the same time. The main display ((6)) changes to *RD2*. This function is working properly if output ((12)Yrs) is OFF (no electrical continuity across terminals (12) and (13)).
4. Release the key to return to the regular mode.

**Note:** DC output is also maintained during periodic inspection.

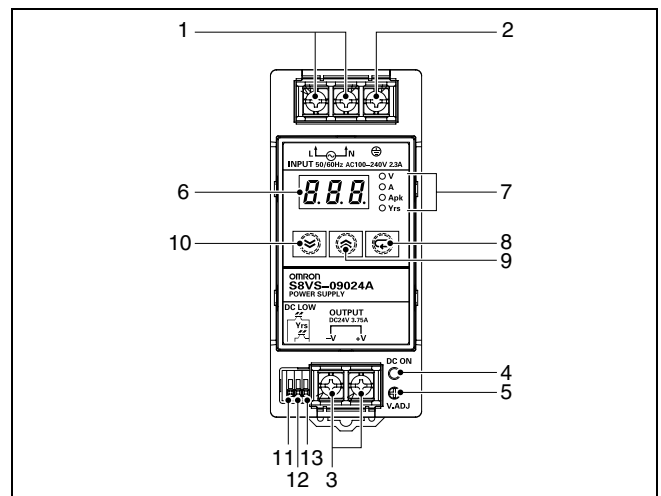

## Charging the Battery

If a battery is to be connected as the load, mount an overcurrent limiting circuit and an overvoltage protection circuit.

## Output Voltage Adjuster

Do not add unnecessary power. The output voltage adjuster (V.ADJ) may be damaged.

## DIN Track Mounting

To mount the Block on a DI track, hook portion (A) of the Block onto the track and press the Block in direction (B).

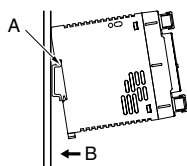

To dismount the Block, pull down portion (C) with a flat-blade screwdriver and pull out the Block.

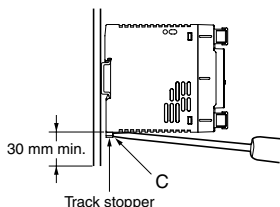

## Series Operation

Two power supplies can be connected in series.

The (±) voltage output can be accomplished with two power supplies.

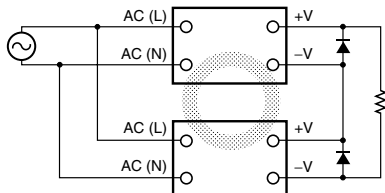

**Note: 1.** Connect the diode as shown in the figure. If the load is short-circuited, a reverse voltage may be applied inside the power supply unit, causing deterioration or breakage of the power supply unit.

Select a diode having the following ratings.

Type	Schottky Barrier diode
Dielectric strength (VRRM)	Twice the rated output voltage or above
Forward current (IF)	Twice the rated output current or above

**2.** Though products having different specifications can be connected in series, the current flowing through the load must not exceed the smaller rated output current.

## Parallel Operation

The product is not designed for parallel operation.

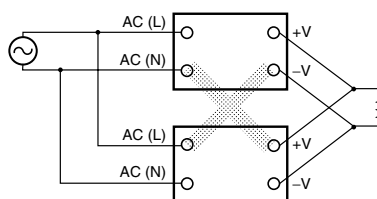

## In Case There is No Output Voltage

The possible cause for no output voltage may be the presence of an overload or overvoltage condition, or may be due to the functioning of a latching protective device. The latching protection may operate if a large amount of surge voltage such as a lightning surge occurs while turning on the power supply.

In case there is no output voltage, please check the following points before contacting us:

Check the Overload Protected Status:

- Check whether the load is in overload status or is short-circuited. Remove wires to load when checking.
- Attempt to clear the overvoltage or latching protection function: Turn the power supply off once, and leave it off for at least 3 minutes. Then turn it on again to see if this clears the condition.

ALL DIMENSIONS SHOWN ARE IN MILLIMETERS.

To convert millimeters into inches, multiply by 0.03937. To convert grams into ounces, multiply by 0.03527.

# Switch mode Power Supply S8PS

## The Most Compact DIN-track-mounting Switch mode Power Supplies Ever with Capacities Up to 600 W

- Power range from 50 W up to 600 W.
- Open-frame and covered types available.
- Easily mounted to DIN track with provided Mounting Brackets.
- Models with Front-mounting Bracket available.
- Conforms to EMC standards: EN50081-1, EN50082-2, and EN61000-3-2.
- Maintenance-free up to 300 W due to natural ventilation.
- Protection-ON alarm indicator shows valuable protection functions in action (300-/600-W models).
- AC universal input: 100 to 240 VAC
- Approved by UL/CSA standards, EN60950 (IEC950), and VDE0160.
- Six-language instruction manual provided.
- Life expectancy of 10 years min.
- Finger protection terminal block meets VDE0106/P100. (Covered type)



## Model Number Structure

### Model Number Legend

S8PS-□□□□□□□□  
1 2 3

#### 1. Power Ratings

- 050: 50 W
- 100: 100 W
- 150: 150 W
- 300: 300 W
- 600: 600 W

#### 2. Output Voltage

- 05: 5 V
- 12: 12 V
- 24: 24 V

#### 3. Configuration

- C: Covered type with Front-mounting Bracket
- D: Open-frame type with DIN Track Mounting Bracket
- CD: Covered type with DIN Track Mounting Bracket
- None: Open-frame type with Front-mounting Bracket

## Ordering Information

### List of Models

Configuration	Input voltage	Power ratings	Output voltage	Output current	Front-mounting Bracket	DIN Track Mounting Bracket	
Covered type	100 to 240 VAC	50 W	5 V	10 A	S8PS-05005C	S8PS-05005CD	
			12 V	4.2 A	S8PS-05012C	S8PS-05012CD	
			24 V	2.1 A	S8PS-05024C	S8PS-05024CD	
		100 W	24 V	4.5 A	S8PS-10024C	S8PS-10024CD	
			150 W	24 V	6.5 A	S8PS-15024C	S8PS-15024CD
				300 W	24 V	14 A	S8PS-30024C
600 W	24 V	27 A	S8PS-60024C	---			
Open-frame type	100 to 240 VAC	50 W	5 V	10 A	S8PS-05005	S8PS-05005D	
			12 V	4.2 A	S8PS-05012	S8PS-05012D	
			24 V	2.1 A	S8PS-05024	S8PS-05024D	
		100 W	24 V	4.5 A	S8PS-10024	S8PS-10024D	
		150 W	24 V	6.5 A	S8PS-15024	S8PS-15024D	
			24 V	6.5 A	S8PS-15024	S8PS-15024D	

# Specifications

## ■ Ratings/Characteristics

Item		50 W	100 W	150 W	300 W	600 W
Efficiency (typical)		75 to 87% (depends on the model)				
Input	Voltage	100 to 240 VAC (85 to 264 VAC)				
	Frequency	47 to 450 Hz				
	Current (see note 1)	0.9 or 0.45 A max.	1.8 or 0.9 A max.	2.7 or 1.4 A max.	5.4 or 2.7 A max.	10 or 5 A max.
	Power factor (see note 1)	0.95 TYP.				
	Leakage current (see note 1)	0.5 or 1.0 mA max.				
	Inrush current (25°C, cold start) (see note 1)	25 or 50 A max.				
Output	Voltage adjustment range	-5% to 10%				
	Ripple (see note 1)	2% (p-p) max.				
	Input variation influence	0.4% max. (at 85 to 132 VAC input/at 170 to 264 VAC input, 100% load)				
	Load variation influence	0.8% max. (with rated input, 0 to 100% load)				
	Temperature variation influence (see note 1)	0.05%/°C max.				
	Rise time	1,000 ms max. (up to 90% of output voltage at rated output voltage/current)				
	Hold time (see note 1)	20 ms min.				
Additional function	Overload protection	105% min., voltage trailing intermittent operation (With the 600-W model, output is turned OFF at 5 s min.)				
	Overvoltage protection	Yes				
	Overheat protection	No				Yes
	Protection-ON alarm indicator	No			Yes (Red)	
	Parallel operation	No			Yes, 2 units max.	
Other	Heat radiation	Natural air-cooling				Fan
	Ambient temperature	Operating: See the derating curve in the <i>Engineering Data</i> section. (with no condensation nor icing) Storage: -25°C to 65°C (with no condensation nor icing)				
	Ambient humidity	25% to 85%				
	Dielectric strength	3.0 kVAC, 50/60 Hz for 1 min (between all inputs and outputs) 2.2 kVAC, 50/60 Hz for 1 min (between all inputs and GR terminals) 1 kVAC, 50/60 Hz for 1 min (between all outputs and GR terminals)				
	Insulation resistance	100 MΩ min. (between all output and input/GR terminals at 500 VDC)				
	Vibration resistance	10 to 55 Hz, 0.75-mm amplitude for 2 h each in X, Y, and Z directions				
	Shock resistance	300 m/s <sup>2</sup> , 3 times each in ±X, ±Y, and ±Z directions				
	Output indicator	Yes (green)				
	Terminal screw tightening torque	1.08 N·m (see note 2)				
	Electromagnetic interference	Conforms to FCC Class B, EN50081-1				
	EMC	(EMI): EN50081-1 Emission Enclosure: EN55022 class B Emission AC Mains: EN55022 class B Harmonic Current: EN61000-3-2 (EMS): EN50082-2 Immunity ESD: EN61000-4-2: 4-kV contact discharge (level 2) 8-kV air discharge (level 3) Immunity RF-interference: ENV50140: 10 V/m (80 MHz to 1 GHz) (level 3) Immunity Conducted Disturbance: ENV50141: 10 V (0.15 to 80 MHz) (level 3) Immunity Burst: EN61000-4-4: 2-kV power-line (level 3) 2-kV output line (level 4) Immunity Surge: EN61000-4-5: between 3-kV lines between 4.5-kV line and FG				
	Approved standards	UL508, UL1012, CSA C22.2 No. 950, CSA C22.2 No. 14, EN60950, VDE0160. Conforms to UL1950 and CSA E.B. 1402C				
	Reliability (MTBF) (see note 3)	135,000 hrs min.				60,000 hrs min.
	Life expectancy (see note 4)	10 yrs. min. (Used at 40°C at the rated input with a 50% load, standard installation)				
	Weight (see note 5)	420 g max.	600 g max.	900 g max.	2,200 g max.	3,500 g max.
	Mounting method	Front-mounting Bracket or DIN Track Mounting Bracket				Front-mounting Bracket

- Note:**
- 100% load for rated input voltage (100 VAC or 200 VAC)
  - Do not press down on the terminal block with a force exceeding 75 N while tightening the terminals.
  - MTBF stands for Mean Time Between Failures, which is calculated according to the probability of accidental device failures, and indicates reliability of devices. Therefore, it does not necessarily represent a life of the product.
  - The life expectancy shown in the above table indicates average operating hours under the ambient temperature of 40°C and a load rate of 50%. Normally this is determined by the life expectancy of the built-in aluminum electrolytic capacitor. It must be noted that the life expectancy of the fan built into the 600-W model is not included.
  - The weight indicated is for the open-frame type. (Includes the cover for 300-W and 600-W models.)

# Connections

## Block Diagrams

S8PS-050□□□□ (50 W)

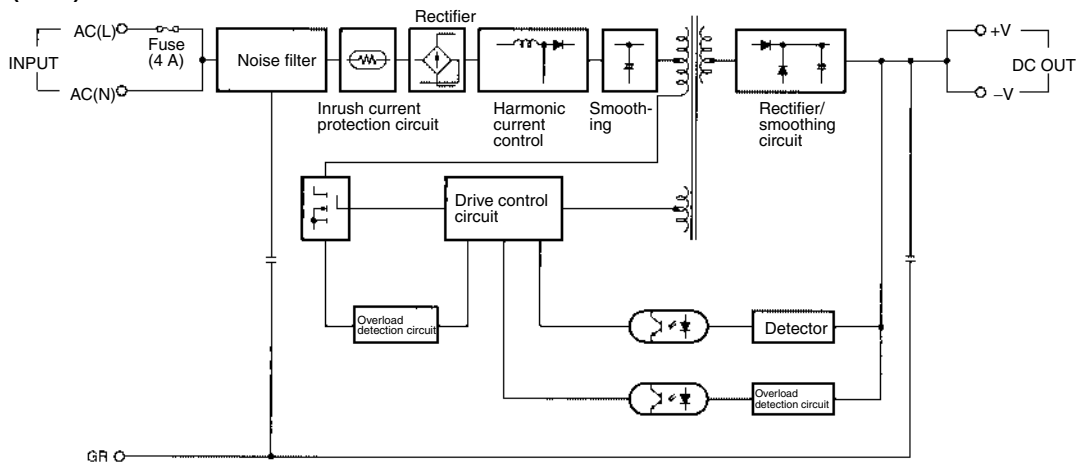

S8PS-10024□□ (100 W)  
 S8PS-15024□□ (150 W)  
 S8PS-30024□□ (300 W)

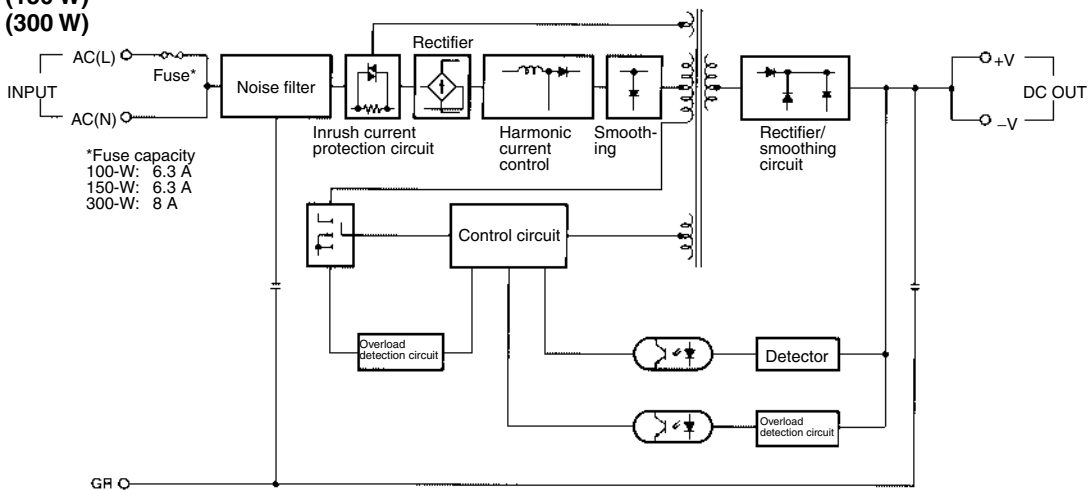

S8PS-60024C (600 W)

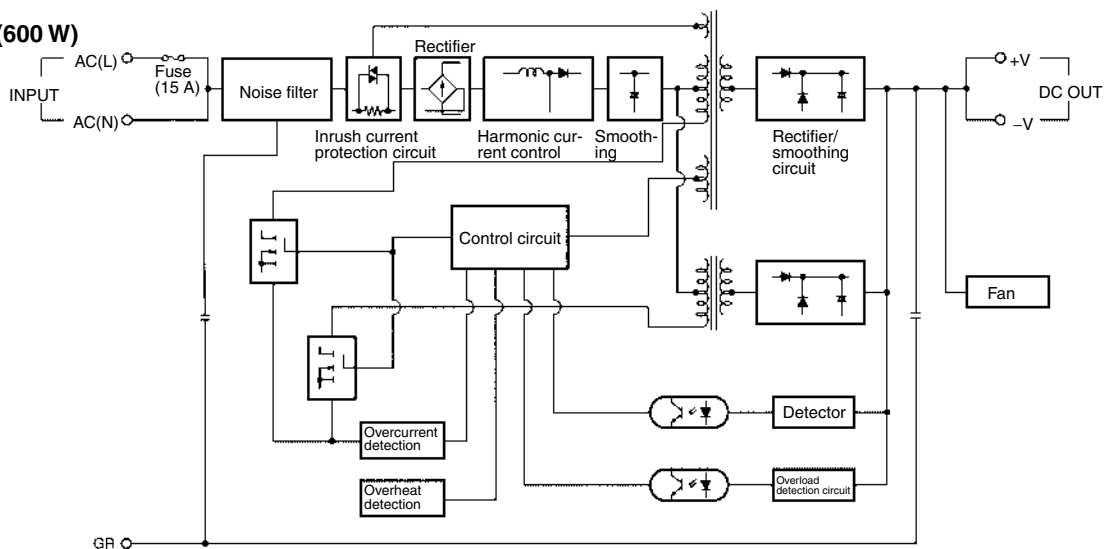

## ■ Installation

### 50-W Models

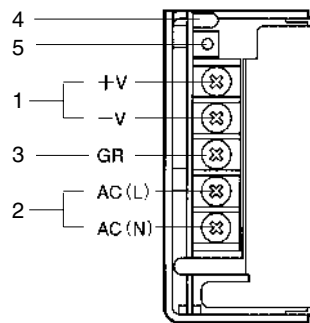

### 100-/150-W Models

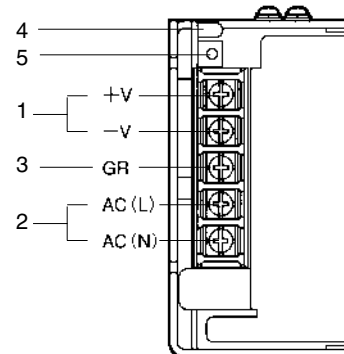

### 300-W Models

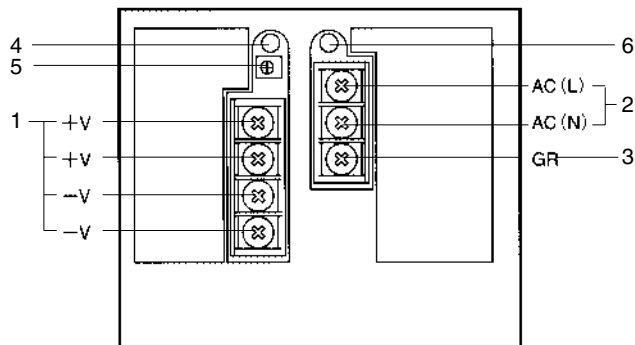

### 600-W Models

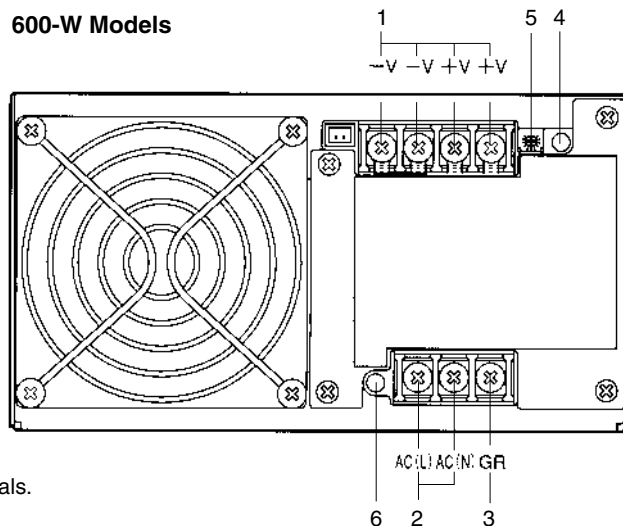

1. **DC Output Terminals:** Connect the load lines to these terminals.
2. **Input Terminals:** Connect the input lines to these terminals.  
**Note:** A fuse is inserted into the AC (L) side.
3. **Ground Terminal (GR):** Connect a ground line to this terminal.
4. **Output Indicator (DC ON):** Lights while a Direct Current (DC) output is ON.
5. **Output Voltage Adjuster (V.ADJ):** It is possible to increase or decrease the output voltage by 10%.
6. **Protection-ON Alarm Indicator:** The red indicator will be lit if the overvoltage (for a 300-/600-W model) or overheat protection (for a 600-W model) circuit is triggered. This indicator will also be lit when overcurrent (for a 600-W model) is detected.



# Engineering Data

## Derating Curve

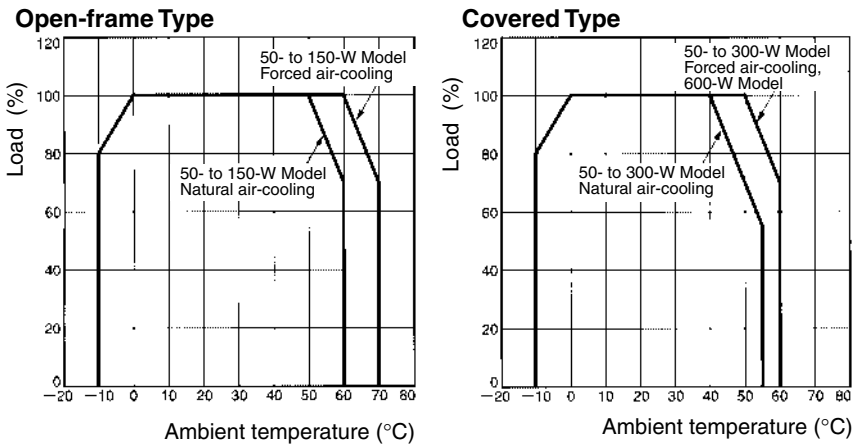

**Note:** 1. Forced air-cooling must be provided with an air volume of 1 m<sup>3</sup>/min.  
 2. The derating curve shown is for standard installation. The derating curve depends on the mounting direction of the Power Supply.

### Standard Installation 50-W Model

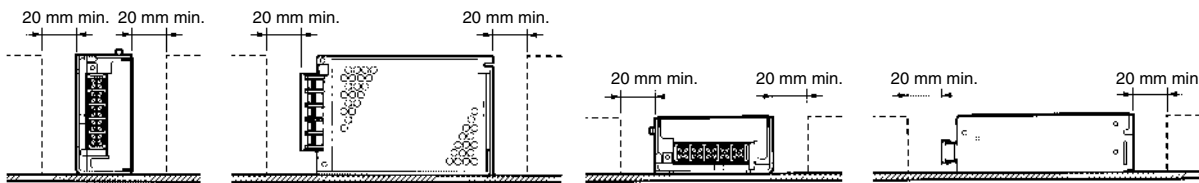

### Standard Installation 100/150-W Model

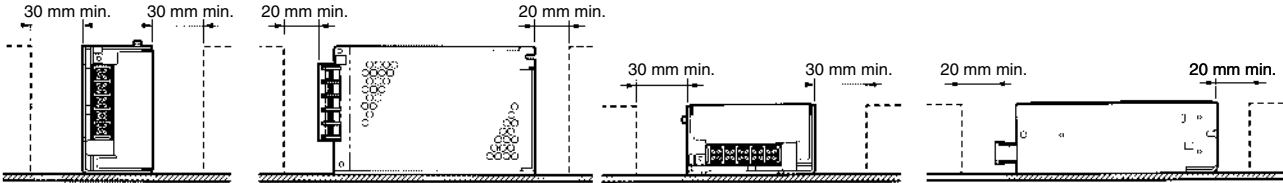

### Standard Installation 300-W Model

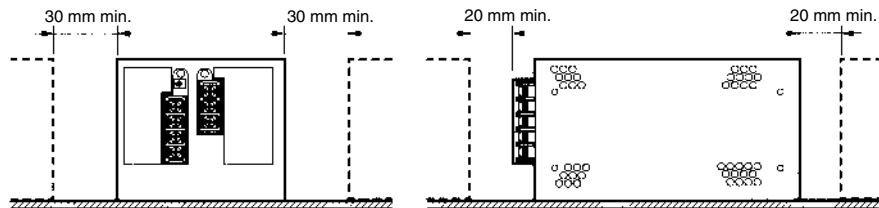

### Standard Installation 600-W Model

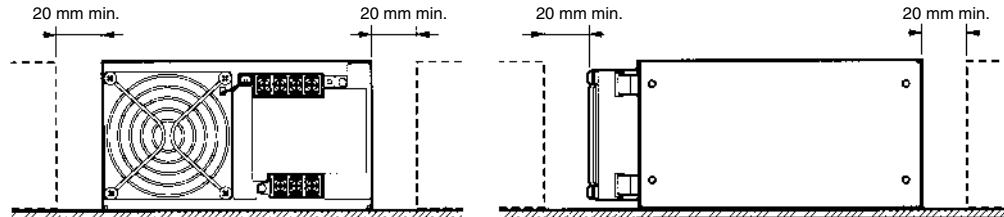

## ■ Overload Protection

### 50- to 300-W Models

The Power Supply is provided with an overload protection function that protects the load and the power supply from possible damage by overcurrent. The protection function operates when the load current rises above an overcurrent set value (105% of the rated load current). For a short-circuit or overcurrent lasting less than 20 seconds, output voltage is decreased to protect equipment. When the output current falls within the rated range, the overload protection function is automatically cleared.

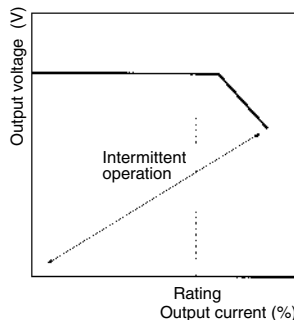

**Note:** Do not continue using the S8PS under short-circuited or overcurrent conditions for longer than 20 seconds, otherwise the internal elements of the S8PS may be damaged or broken.

### 600-W Models

If an excessive current flows for 5 s or more, the output will be turned OFF and simultaneously protection-ON alarm indicator will be lit. To reset the S8PS, turn OFF the input voltage, leave the S8PS for at least three minutes, and then apply the input voltage again.

**Note:** Do not continue using the S8PS with the output terminals short-circuited or the overcurrent condition continued, otherwise the internal elements of the S8PS may be damaged or broken.

## ■ Overvoltage Protection

The Power Supply is provided with an overvoltage protection function that protects the load and the Power Supply from possible damage by overvoltage. When the output voltage rises above a set value (115% of the rated output voltage), the protection function is triggered, shutting OFF the output voltage. If this occurs, reset the Power Supply by turning it OFF for 1 minute min. and then turning it ON again.

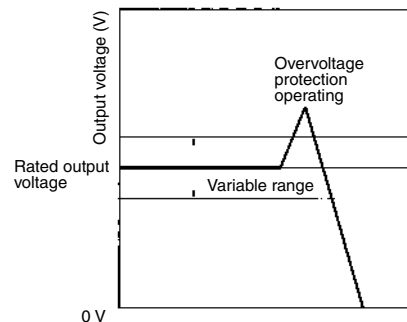

### 300- and 600-W Models Only

The overvoltage protection-ON alarm indicator lights when the function is operating.

## ■ Overheat Protection Function

### 600-W Model Only

If the internal temperature of the S8PS rises excessively as a result of fan failure or any other reason, the overheat protection circuit will be triggered to protect the internal elements of the S8PS and simultaneously a protection-ON alarm indicator will be lit. To reset the S8PS turn OFF the input voltage, leave the S8PS for at least one minute and then apply the input voltage again.

## ■ Inrush Current, Rise Time, Hold Time

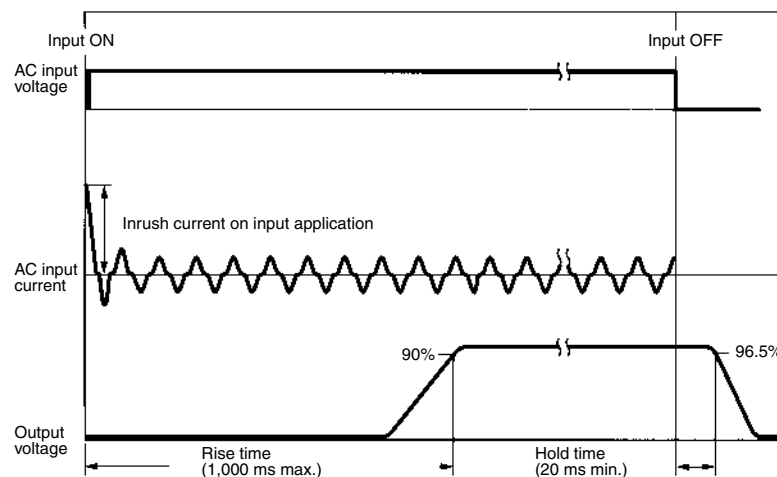

# Dimensions

Note: All units are in millimeters unless otherwise indicated.

## ■ Front-mounting Bracket Type

The Front-mounting Bracket is provided as an accessory. Screws for fixing the Bracket to the panel are not provided.

S8PS-050□□ (50 W)  
S8PS-050□□□C (50 W)

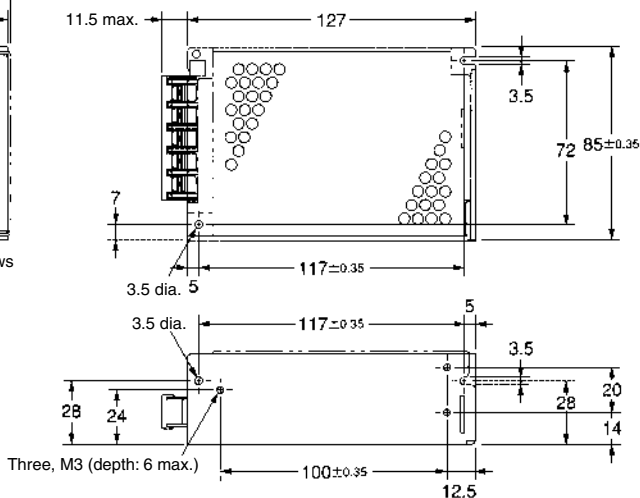
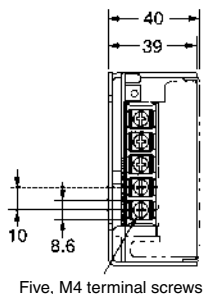
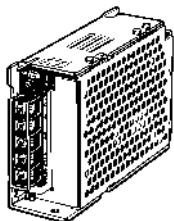

### Front-mounting Bracket for 50-W Models

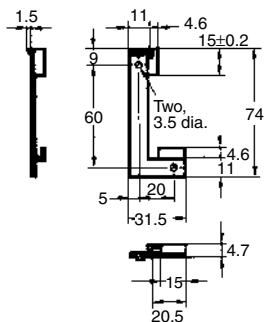

### Mounting Holes

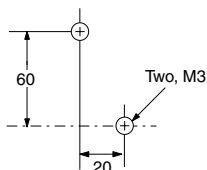

### Using the Mounting Bracket

Attach the Mounting Bracket to the panel and loosely tighten the two screws. Insert the projected parts of the Bracket (b) to the square holes of the power supply (a). Then securely tighten the screws.

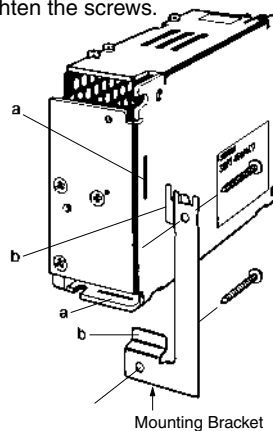

S8PS-10024 (100 W)  
S8PS-10024C (100 W)

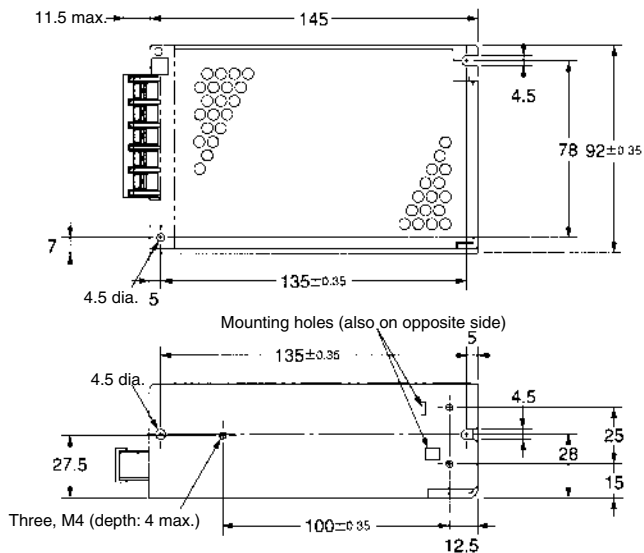
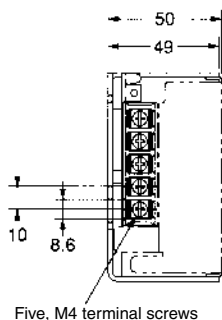
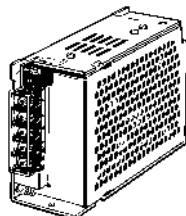

**S8PS-15024 (150 W)**  
**S8PS-15024C (150 W)**

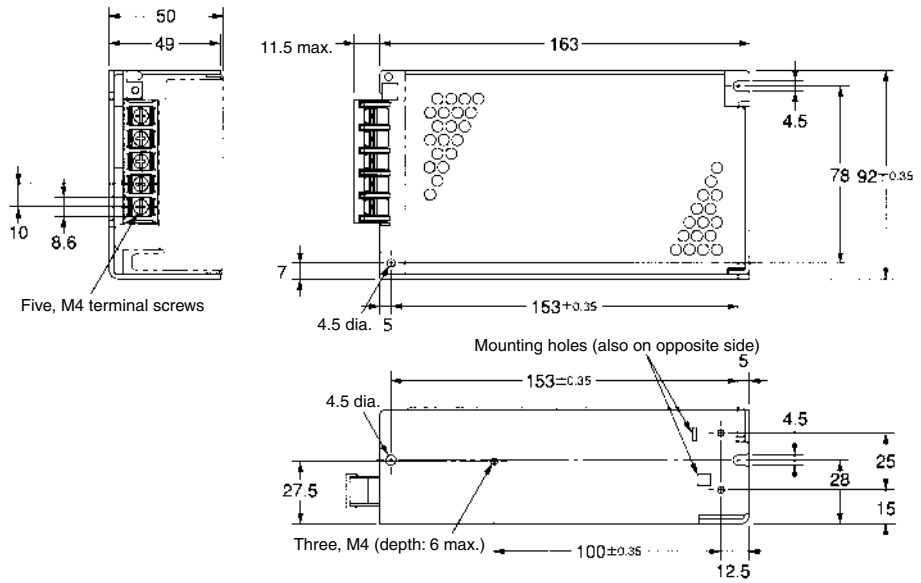
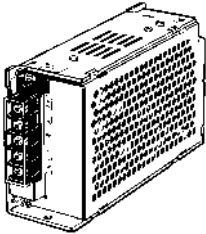

**Front-mounting Bracket for 100/150-W Models**

**Appearance and Mounting Dimensions**

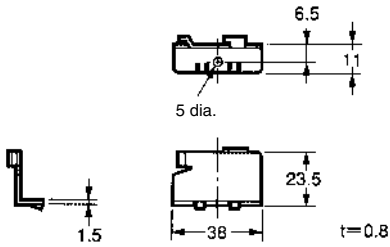

**Dimensions with Mounting Bracket**

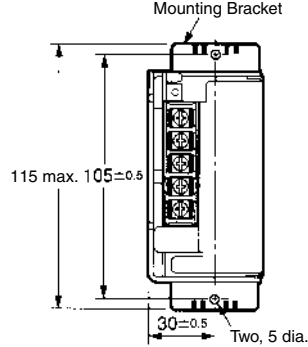

**Using the Mounting Bracket**

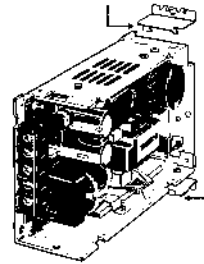

**S8PS-30024C (300 W)**

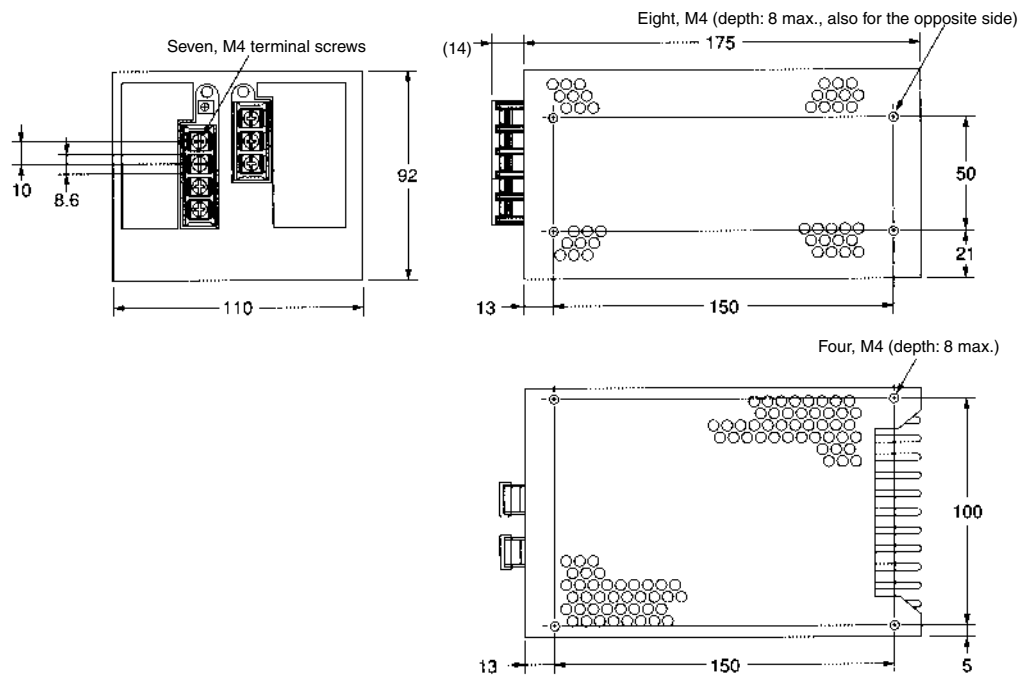
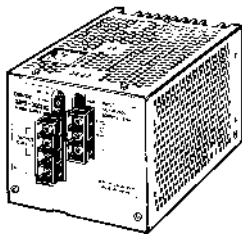

**S8PS-60024C (600 W)**

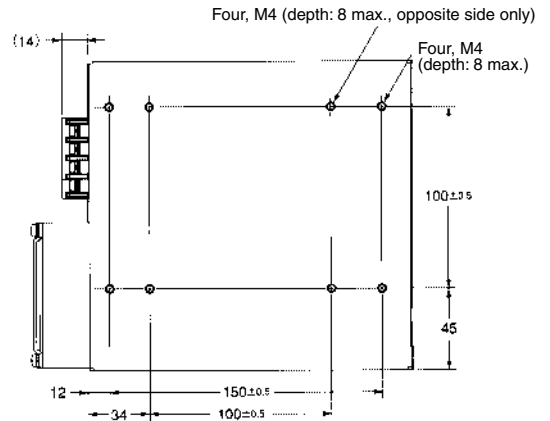
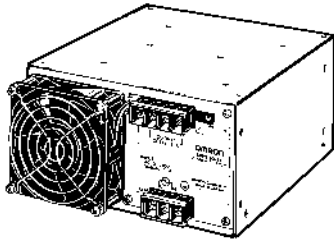
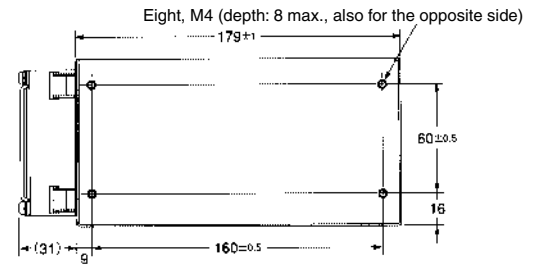
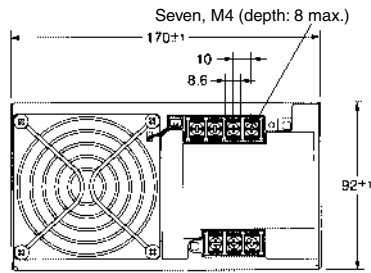

**Front-mounting Bracket for 300/600-W Models**

**Appearance and Mounting Dimensions**

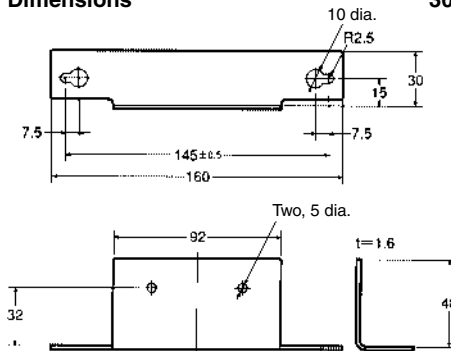

**Dimensions with Mounting Bracket**

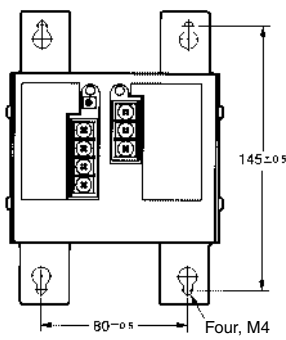

**Using the Mounting Bracket**

**Note:** Four screws for attaching the Bracket to the Power Supply Unit are provided.

**300-W models**

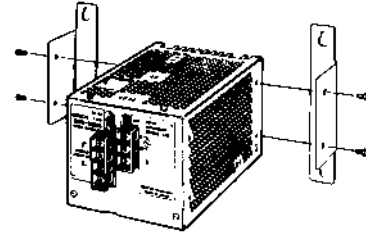

**Note:** Mount the Unit 21.6 mm away from the mounting surface in order to provide air ventilation on the rear side.

**600-W models**

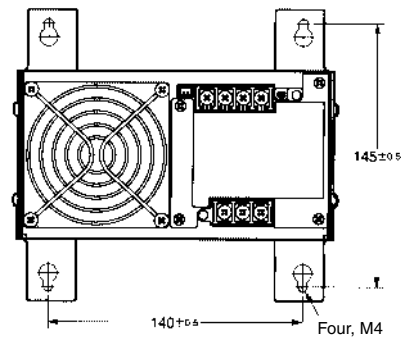

**600-W models**

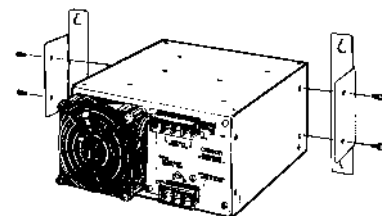

**Note:** Mount the Unit 28 mm away from the mounting surface in order to provide air ventilation on the rear side.

## ■ DIN Track Mounting Bracket Type

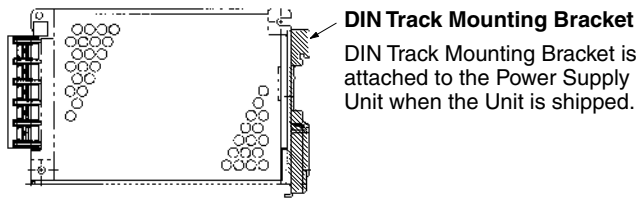

**S8PS-050□□D (50 W)**  
**S8PS-050□□□CD (50 W)**

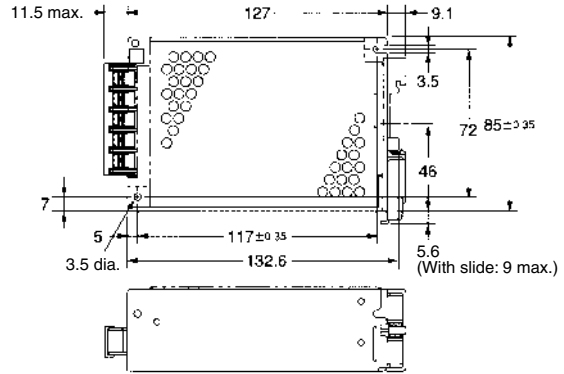
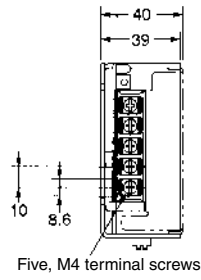
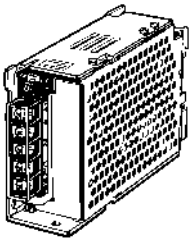

**S8PS-10024D (100 W)**  
**S8PS-10024CD (100 W)**

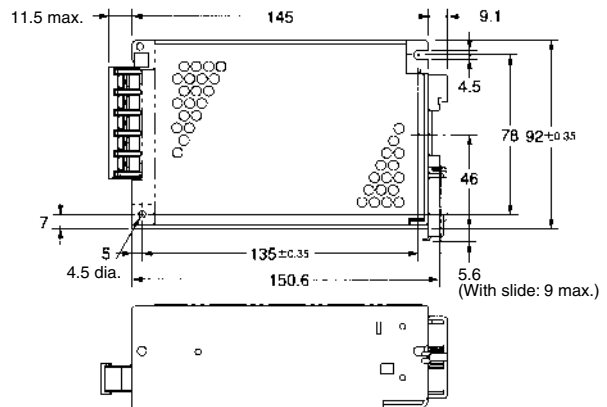
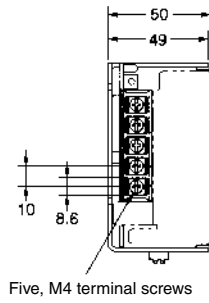
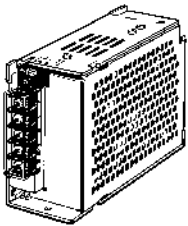

**S8PS-15024D (150 W)**  
**S8PS-15024CD (150 W)**

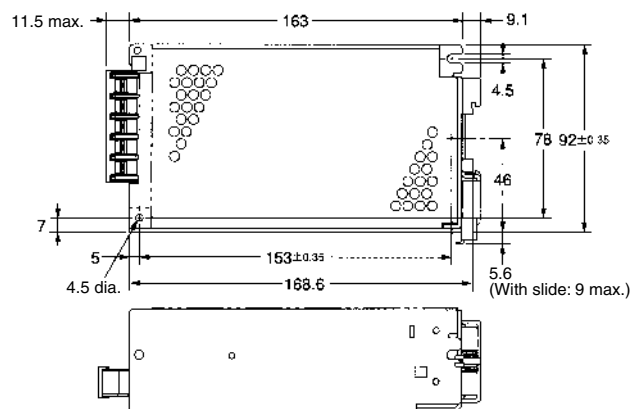
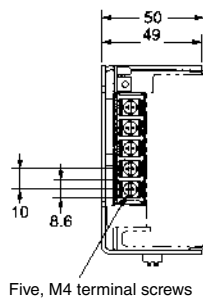
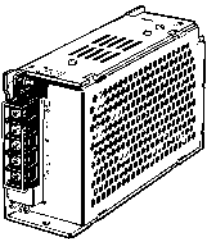

**S8PS-30024CD (300 W)**

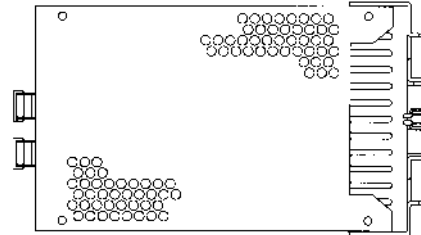
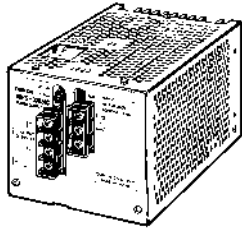
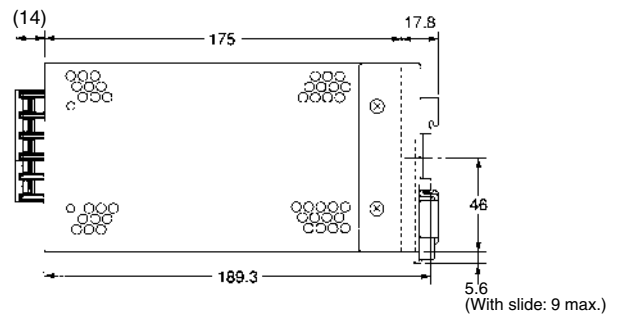
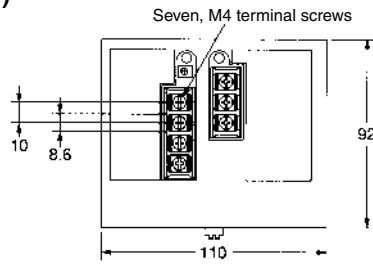

**Accessories**

**Mounting Track (Order Separately)  
PFP-100N/PFP-50N**

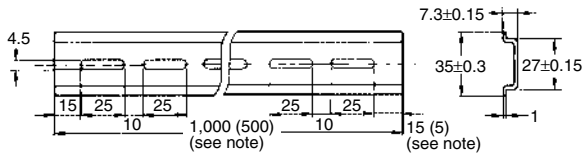
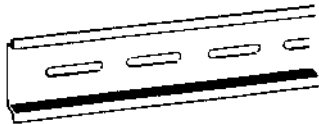

**PFP-100N2**

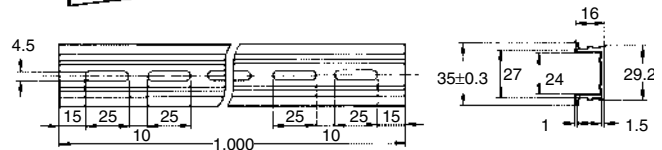

**Note:** The values shown in parentheses are for the PFP-50N.

# Precautions

**Caution**

Be sure to connect the grounding line. Not doing so may result in electric shock.

**WARNING**

Do not attempt to disassemble the Power Supply or touch its internal parts while power is being supplied. Doing so may result in electric shock.

Do not touch the terminals of the Power Supply within one minute after power has been turned OFF. Doing so may result in electric shock due to a residual voltage.

Do not touch the S8PS or heat radiation fin while the power is being supplied or immediately after the power is turned OFF. Otherwise, a skin burn may result from the hot Switching Power Supply or radiator.

## Mounting

To improve and maintain the reliability of the Power Supply over a long period of time, adequate consideration must be given to heat radiation.

The Power Supply is designed to radiate heat by means of natural air-flow. Therefore, mount the Power Supply so that air flow takes place around the Power Supply.

When mounting the Power Supply, mounting it to a metal plate is recommended.

Forced air-cooling is highly recommended.

It is recommended that the clearance around the Power Supply be larger than those shown on page page 71 under *Standard Installation*.

## Generating Output Voltage (±)

An output of ± can be generated by using two Power Supplies as shown below, because the Power Supply produces a floating output.

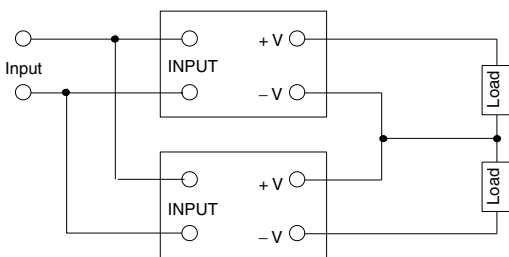

## Series Operation

Only models with power ratings of 100/150 W allow series operation.

As shown in the following diagram, the output voltage from each Switching Power Supply can be added.

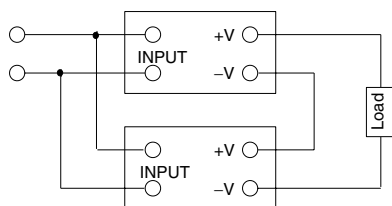

## Parallel Operation

Only 300- and 600-W models can be in parallel operation provided that they are operated under 90% of the ratings. Do not operate any other models in parallel.

Make sure that the thickness and the length of all wires connected to the load are the same to ensure that the wires will have no voltage drop differences.

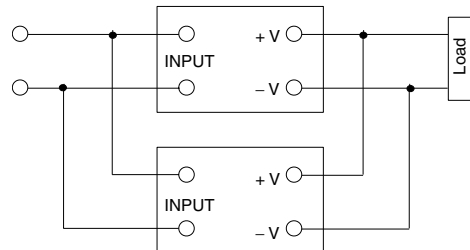

## Fan Replacement

The service life of the fan is approximately 50,000 hours (at 25°C). The service life varies, however, depending on the ambient temperature or other surrounding environmental conditions such as dust. As a preventive maintenance measure, replace the fan within two years if it is used at an ambient temperature of 40°C.

Fans are available as replacements.

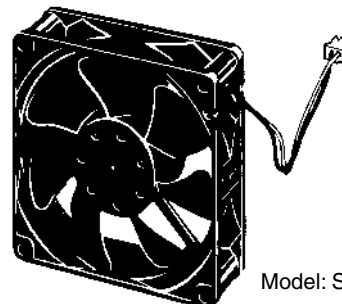

Model: S82Y-JFAN

Fan Set:

Fan (above), four M4 x 35 sems screws, instruction sheet, and packing case

Replace the fan as shown in the following illustration.

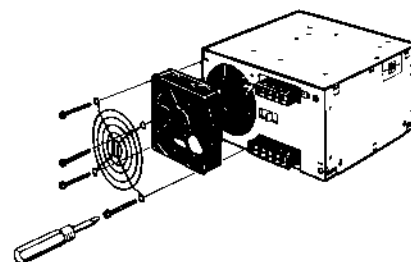

ALL DIMENSIONS SHOWN ARE IN MILLIMETERS.  
To convert millimeters into inches, multiply by 0.03937. To convert grams into ounces, multiply by 0.03527.