

### Description

The YB1210 family consists of a series of 300mA ultra-low-noise, low dropout (LDO) linear regulators especially designed for battery-powered RF and wireless applications. The YB1210 regulator achieves a low 450mV dropout at 250mA load current of 3.3V output, ultra-low output voltage noise of 15µVrms and PSRR of 57dB at 1KHz.

The YB1210 regulators are also optimized to work with low-ESR and low cost ceramic capacitors reducing the amount of board space critical in hand-held devices. The YB1210 requires only 0.47 µF output capacitor for stability with any load. The YB1210 consumes less than 1µA in shutdown mode.

Other features include high output voltage accuracy and current limiting protection. The YB1210 regulators are available in SOT-23 / SOT-25 / SOT-89 packages.

### Features

- High Accuracy +/-2% Output Voltage
- Ultra-Low-Noise Low-Drop-Out Regulator with 1.8/2.5/2.6/2.8/3.0V/3.3V Preset Outputs
- Stable with 0.47µF Ceramic Capacitor for Any Load
- Allowable Output Current: 300mA
- Low Quiescent Current: ~90µA
- 450mV Dropout at 250mA Load (3.3V)
- Only Need Input and Output Capacitors
- Power Saving Shutdown Mode (<1µA)
- Thermal Protection Shutdown
- Built-In Internal Soft-Start
- Output Short-circuit Current Limit Protection
- Green package (RoHS) available

### Applications

- PDA, Palmtops and Notebook Computers
- DSC, Handset Camera Modules
- PCMCIA Cards, PC Cameras
- USB Based Portable Devices (MP3, PMP)
- GSM/GPRS/3G RF Transceiver Modules
- Wireless LANs
- Bluetooth Portable Radios

### Typical Application Circuitry

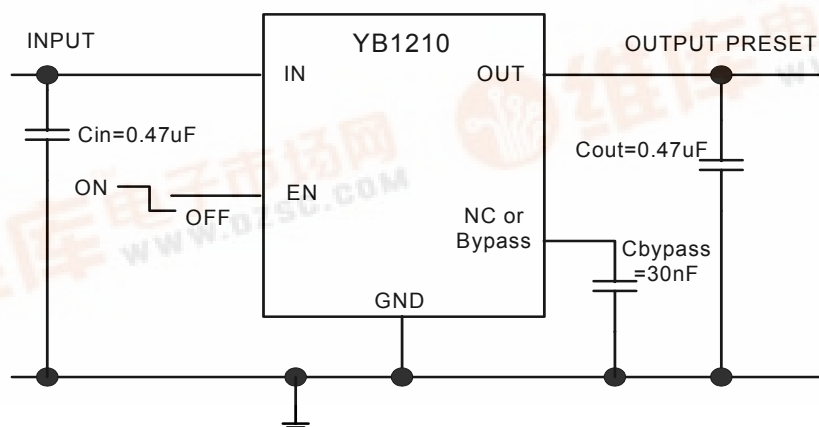

Figure 1-1. SOT-25 application circuit



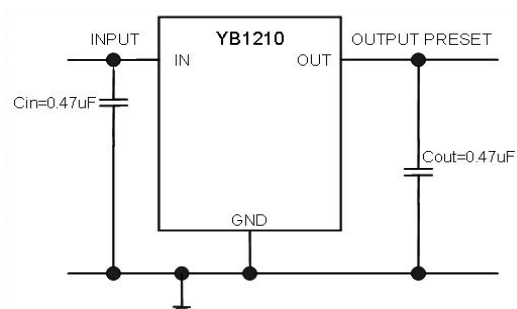

Figure 1-2. SOT-23 / SOT-89 application circuit

### Pin Configuration

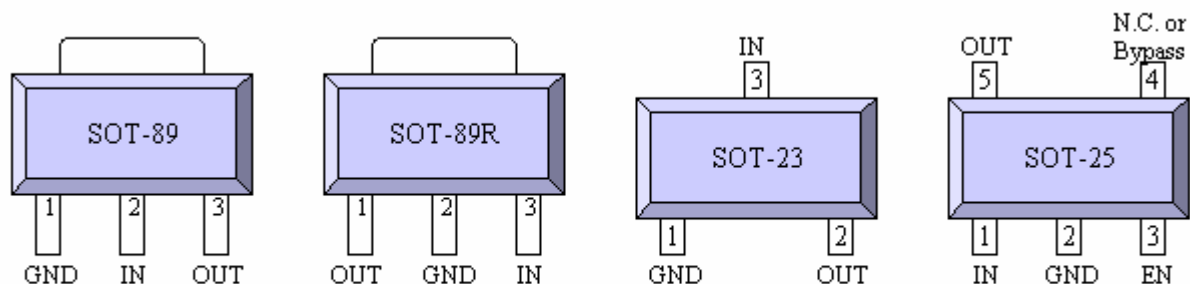

Figure 2 : pin configuration

### Pin Description

Table 1

Pin	Name	SOT-25 Description	Pin	Name	SOT-89 Description		
1	IN	Unregulated Input Supply	1	GND	Ground Pin		
2	GND	Ground Pin	2	IN	Unregulated Input Supply		
3	EN	Pull High To Enable The Regulator	3	OUT	Regulated Voltage Output		
4	N.C. or Bypass	No Connection For Normal Operation Or Noise Bypass For Ultra-Low-Noise Operation By A 30nF Cap. To GND	<th>Pin</th> <th>Name</th> <th>SOT-89R Description</th>		Pin	Name	SOT-89R Description
5	OUT	Regulated Voltage Output	1	OUT	Regulated Voltage Output		
<th>Pin</th> <th>Name</th> <th>SOT-23 Description</th> <td>2</td> <td>GND</td> <td>Ground Pin</td>		Pin	Name	SOT-23 Description	2	GND	Ground Pin
1	GND	Ground Pin	3	IN	Unregulated Input Supply		
2	OUT	Regulated Voltage Output					
3	IN	Unregulated Input Supply					

### Ordering Information

Y B 1 2 1 0         S -        

Material  
G : Green package

Output Voltage

1 . 8 : 1.8 V  
2 . 5 : 2.5 V  
2 . 6 : 2.6 V  
2 . 8 : 2.8 V  
3 . 0 : 3.0 V  
3 . 3 : 3.3 V

Package Type

ST23 : SOT-23  
ST25 : SOT-25  
ST89 : SOT-89  
ST8R : SOT-89R

- Order example :  
YB1210ST89S-2.5G for YB1210 of 2.5V output and green SOT-89 package
- Shipping Quantity :  
SOT-23 : 3000 units tape & reel  
SOT-25 : 3000 units tape & reel  
SOT-89 : 1000 units tape & reel  
SOT-89R : 1000 units tape & reel

### Marking Information



Output Voltage

Voltage	1.8	2.5	2.6	2.8	3.0	3.3
Code	D	K	L	N	P	S

Package

Package	Marking
SOT25	BD
SOT23	DH
SOT89	EI
SOT89R	FF

### Absolute Maximum Ratings

Supply Voltage ..... -0.3V to 7.0V  
 Output Voltage ..... -0.3V to ( $V_{IN}+0.3V$ )  
 Output Short-Circuit Duration ..... Infinite  
 Junction Temperature Range ..... +150°C  
 Storage Temperature Range ..... -65°C to +150°C  
 Lead Temperature ..... +250°C  
 Thermal Resistance (SOT-23/25,  $\theta_{JA}$ ) ..... 280°C/W  
 Thermal Resistance (SOT-89,  $\theta_{JA}$ ) ..... 180°C/W  
 Internal Power Dissipation (SOT-23/25, PD) ..... 0.4W  
 Internal Power Dissipation (SOT-89, PD) ..... 0.55W

### Recommended Operating Conditions

Input Supply Voltage ..... 2V to 6.0V  
 Operating Temperature ..... -40°C to +85°C  
 ESD Susceptibility (HBM) ..... 2KV  
 ESD Susceptibility (MM) ..... 200V

### Electrical Characteristics

**Table 3**  $T_A = 25^\circ\text{C}$ ,  $V_{IN} = (V_{OUT} + 1\text{V})$ ,  $C_{IN} = C_{OUT} = 0.47\mu\text{F}$ ,  $V_{EN} = V_{IN}$

Function Parameter	Conditions	Min	Typ	Max	Units
Input Voltage Range		2.0		6.0	V
Output Voltage	Predefined (metal masks)	1.8		3.3	V
Output Voltage Accuracy	$I_{OUT} = 10\text{mA}$	-2.0		+2.0	%
Output Current Limit	Short-circuit output		200	250	mA
Dropout Voltage (See Note 1)	$V_{OUT} = 3.3\text{V}$ , $I_{OUT} = 250\text{mA}$		450	550	mV
	$V_{OUT} = 3.0\text{V}$ , $I_{OUT} = 250\text{mA}$		470	590	
	$V_{OUT} = 2.8\text{V}$ , $I_{OUT} = 250\text{mA}$		500	600	
	$V_{OUT} = 2.6\text{V}$ , $I_{OUT} = 250\text{mA}$		520	620	
	$V_{OUT} = 2.5\text{V}$ , $I_{OUT} = 250\text{mA}$		540	640	
	$V_{OUT} = 1.8\text{V}$ , $I_{OUT} = 250\text{mA}$		800	900	
Ground Current	$I_{OUT} = 0\text{mA}$		90	150	$\mu\text{A}$
Line Regulation	$V_{IN} = (V_{OUT}+1\text{V})$ to 6.0V, $I_{OUT} = 10\text{mA}$		0.3	0.5	%/V
Load Regulation	$I_{OUT} = 1\text{mA}$ to 250mA		1.2	3	%
Shutdown Supply Current	EN=0V		~0.01		$\mu\text{A}$

Ripple Rejection (PSRR)	f = 100Hz, I <sub>OUT</sub> =1mA		55		dB
	f = 1KHz, I <sub>OUT</sub> =1mA		57		
	f = 10KHz, I <sub>OUT</sub> =1mA		55		
Output Noise Voltage	f = 100Hz to 100KHz, I <sub>load</sub> =10mA, Bypass=0nF		45		μVrms
	f = 100Hz to 100KHz, I <sub>load</sub> =10mA, Bypass=30nF		15		μVrms
Shutdown Exit Delay <small>(See Note 2)</small>	R <sub>load</sub> =50ohm		45	300	μs
EN Logic Low Level	V <sub>IN</sub> =2.0V to 5.5V			0.4	V
EN Logic High Level	V <sub>IN</sub> =2.0V to 5.5V	1.2		V <sub>IN</sub>	V
EN Input Bias Current	V <sub>IN</sub> =5.5V, SHDN=0V or 6V		0.01		μA
Thermal Shutdown	Shutdown Temperature		160		°C
Thermal-Shutdown Hysteresis			20		°C

**Note1** : The drop out voltage varies depending on output voltage selection

Dropout is defined as V<sub>IN</sub> – V<sub>OUT</sub> when V<sub>OUT</sub> is 100mV below V<sub>OUT</sub> where V<sub>in</sub>=V<sub>out</sub> + 1V for nominal V<sub>OUT</sub>.

**Note 2**: Time needed for V<sub>OUT</sub> to reach 90% of final value.

## Typical Characteristics

At T<sub>A</sub>=25°C, V<sub>IN</sub>=(V<sub>OUT</sub>+0.5V), C<sub>IN</sub>=C<sub>OUT</sub>=0.47μF, V<sub>EN</sub>=V<sub>IN</sub>, unless otherwise noted.

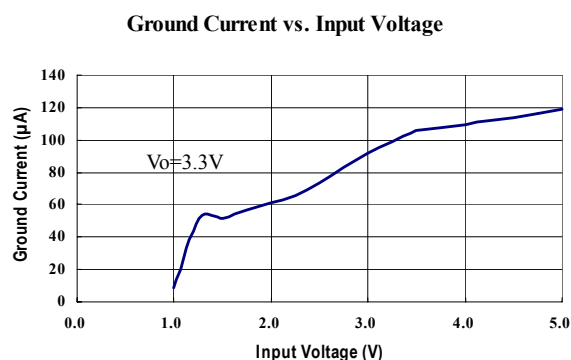
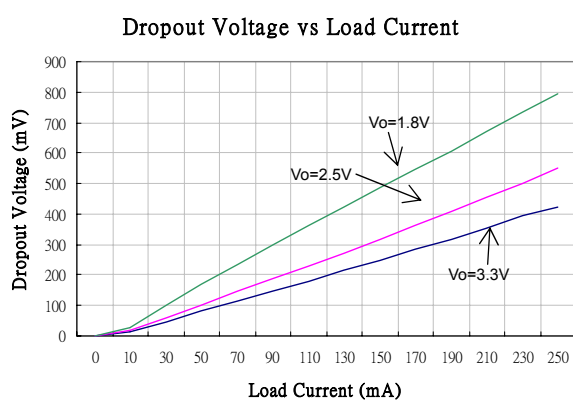

**PSRR vs Frequency (Load=1mA)**

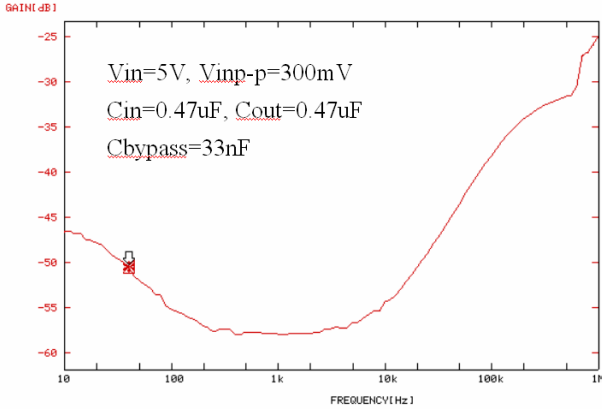

**Output Voltage vs. Temperature**

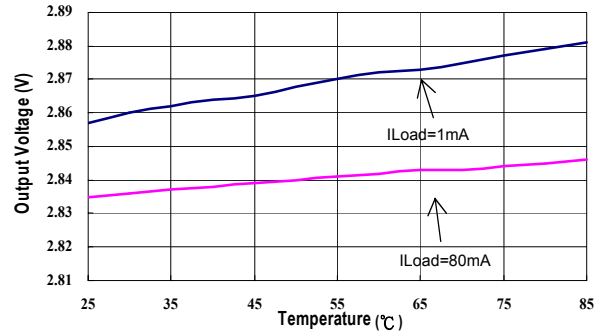

**Dropout Voltage vs Temperature**

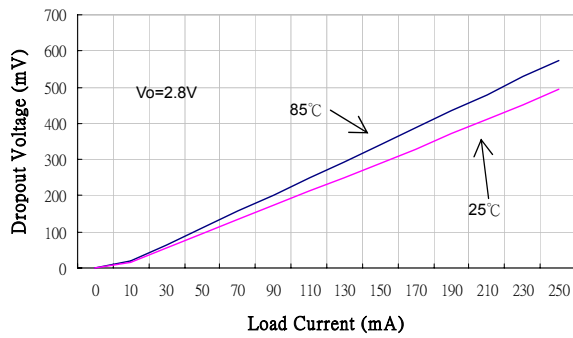

**PSRR vs Frequency (Load=10mA)**

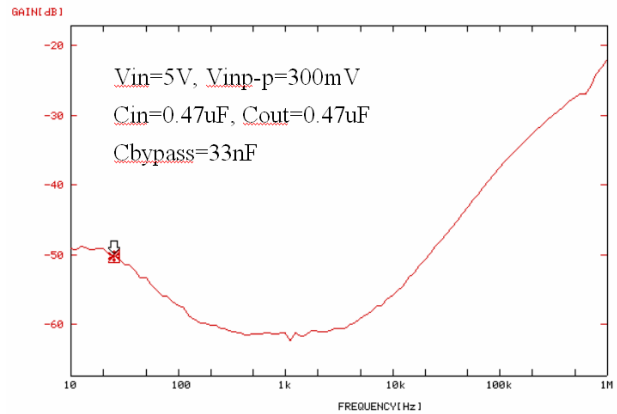

**PSRR vs Frequency (Load=100mA)**

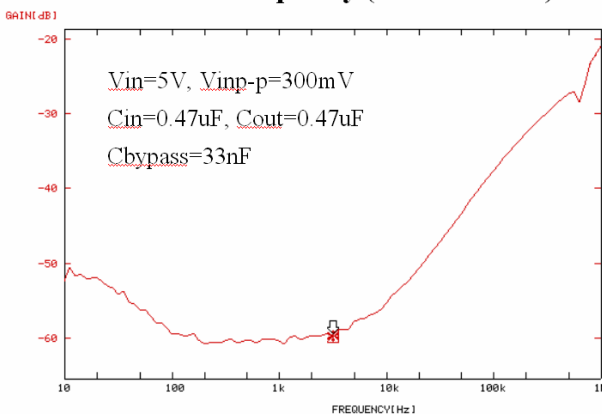

**Shutdown Exit Delay**

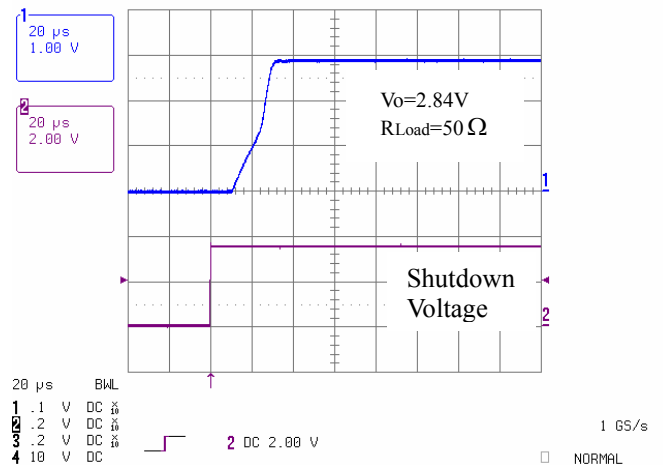

**Line Transient Response**

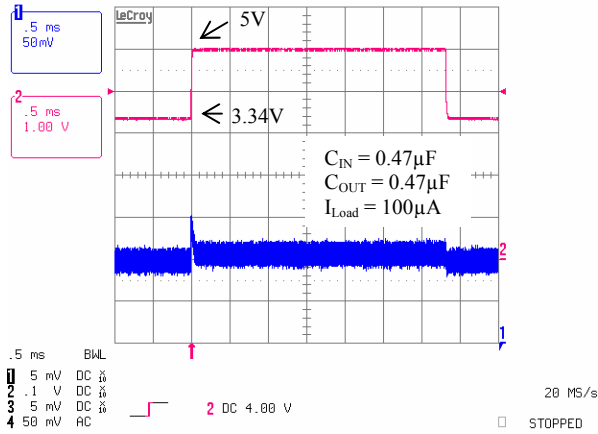

**Load Transient Response**

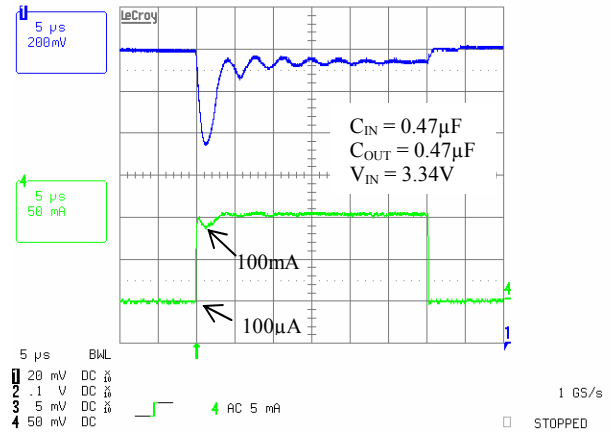

**Shutdown Delay**

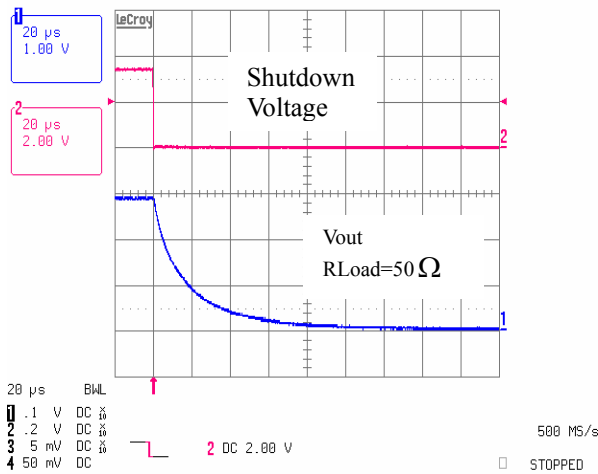

## Functional Block Diagram

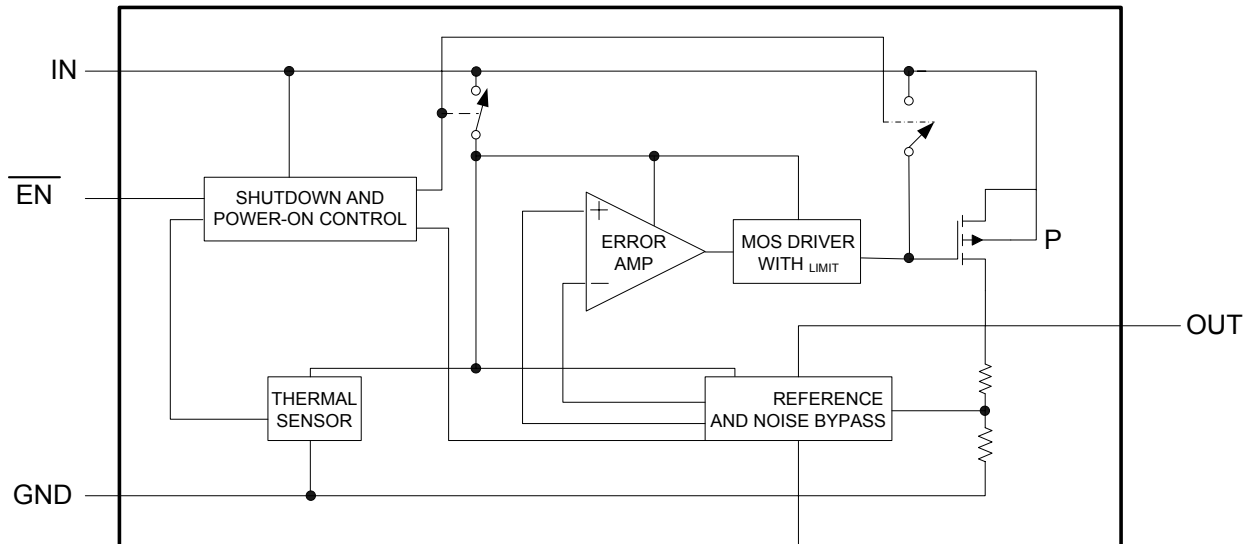

Figure 3. Block Diagram

## Functional Description

The YB1210 is an ultra-low-noise, low-quiescent current, low-dropout linear regulator. It is supplied in a SOT-23 / SOT-25 / SOT-89 package for different applications. These devices can supply loads up to 250mA. As shown in the *Functional Block Diagram*, the YB1210 consists of a reference and noise bypass circuit, error amplifier, output drive transistor, internal feedback voltage divider, thermal sensor, and short circuit current limiter. The internal reference is connected to the error amplifier's inverting input. The error amplifier compares this reference with the feedback voltage and amplifies the difference. If the feedback voltage is lower than the reference voltage, the pass-transistor gate is pulled low. This allows more current to pass to the output and increases the output voltage. If the

feedback voltage is too high, the pass transistor gate is pulled high, allowing less current to pass to the output. The parts are available with preset output voltages ranging from 1.8V to 3.3V.

### Stability

The YB1210 is a high performance LDO emphasizing stability with low output capacitance. It is able to maintain stability with an output capacitor as low as 0.47uF. The output capacitor can also be increased to optimize performance. The YB1210 will remain stable and in regulation with no load, unlike many other voltage regulators.

### Internal P-Channel Pass Transistor

The YB1210 features a low impedance P-channel MOSFET pass transistor. This provides several advantages over similar



designs using a PNP pass transistor, including low operating power and longer battery life. The YB1210 consumes only 90 $\mu$ A of quiescent current under most conditions.

### **Output Short-Circuit Current Limit**

The YB1210 includes a current limiter, which monitors and controls the pass transistor's gate voltage, limiting the output current to about 200mA, for example, in a short-circuit output situation.

### **Shutdown**

The YB1210 also features a low-power active shutdown mode. It has a switch that turns off the device when disabled. This allows the output capacitor and load to discharge and de-energize the load. In the shutdown mode, the internal functional blocks, such as voltage reference and the error amplifier, are turned off completely, and the quiescent current is less than 1 $\mu$ A.

### **Thermal Protection Shutdown**

The thermal protection shutdown function protects the device from operating in over temperature condition. When the junction temperature exceeds +160 $^{\circ}$ C, the thermal sensor signals the shutdown logic, turning off the pass transistor and allowing the IC to cool down. The thermal sensor turns the pass transistor on again after the IC's junction temperature drops to +140 $^{\circ}$ C.

### **Soft-Start Circuitry**

The YB1210 includes a soft-start circuitry to limit inrush current at turn-on. During power

up, the output capacitor and output load are charged with a reduced output current. Shortly after the initial power up, the soft-start feature is terminated and normal operation is resumed.

## **Application Information**

### **Enable/Shutdown**

The YB1210 comes with an active-high enable pin that allows the regulator to be enabled. Forcing the enable pin low disables the regulator and puts it into the shutdown mode. This pin cannot be left floating as it may cause an undetermined state.

### **Input/Output Capacitor**

It is recommended to use a 0.47 $\mu$ F capacitor on the YB1210 input and a 0.47 $\mu$ F capacitor on the output. For high regulation performance, larger input capacitor values and lower ESRs provide better noise rejection and line-transient response. The output noise, load-transient response, stability, and power-supply rejection can be improved by using large output capacitors. Low ESR ceramic capacitors provide optimal performance and save space.

### **Power Supply Rejection and Transient Response**

The PSRR and transient response can be improved by increasing the values of the input and output bypass capacitors, and through passive filtering techniques.

### SOT-25 Package Information

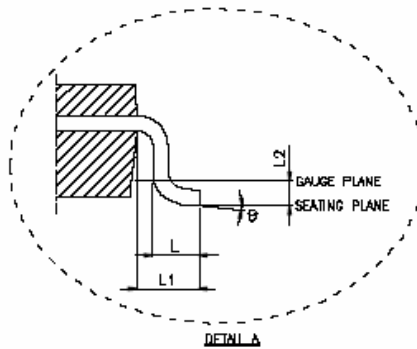
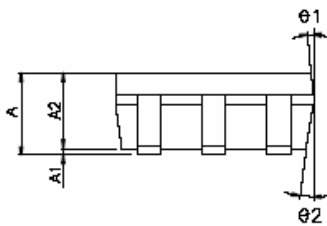
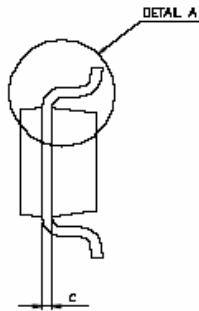
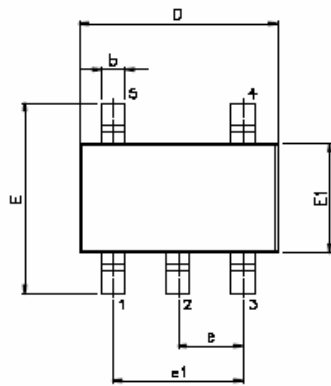

VARIATION(ALL DIMENSIONS SHOWN IN MM)

SYMBOL	MIN.	NOM.	MAX.
A	1.05	1.20	1.35
A1	0.05	0.10	0.15
A2	1.00	1.10	1.20
b	0.25	-	0.50
c	0.08	-	0.20
D	2.70	2.90	3.00
E	2.60	2.80	3.00
E1	1.50	1.80	1.70
e	0.95 BSC.		
e1	1.80 BSC.		
L	0.30	0.45	0.55
L1	0.60 REF.		
L2	0.25 BSC.		
Ø	Ø	5°	10°
Ø1	3°	5°	7°
Ø2	Ø	8°	10°

NOTE : 1.JEDEC OUTLINE : MO-17B AA

### SOT-23 Package Information

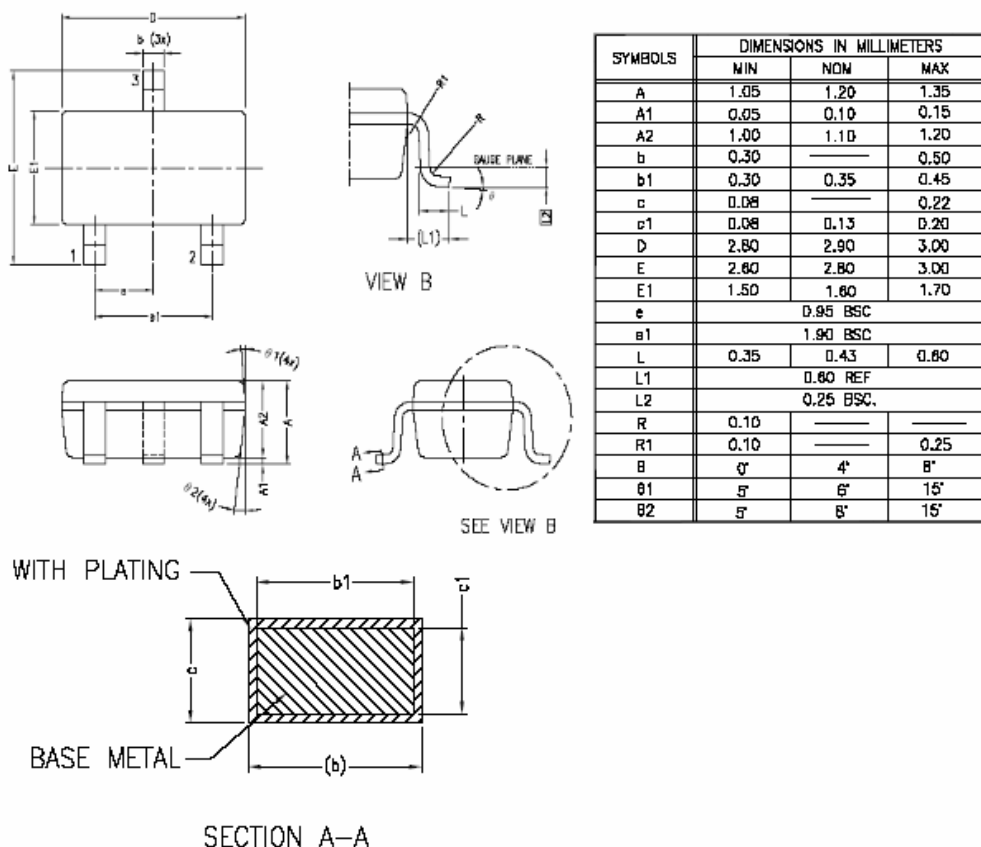

**NOTE:**

- ALL DIMENSIONS ARE IN MILLIMETERS.
- DIMENSION DOES NOT INCLUDE MOLD FLASH, PROTRUSION OR GATE BURRS SHALL NOT EXCEED 0.25mm PER END.  
DIMENSION E1 DOES NOT INCLUDE INTERLEAD FLASH OR PROTRUSION. INTERLEAD FLASH OR PROTRUSION SHALL NOT EXCEED 0.25 PER SIDE.
- THE PACKAGE TOP MAY BE SMALLER THAN THE PACKAGE BOTTOM.  
DIMENSIONS D AND E1 ARE DETERMINED AT THE OUTERMOST EXTREMES OF THE PLASTIC BODY EXCLUSIVE OF MOLD FLASH, THE BAR BURRS. GATE BURRS AND INTERLEAD FLASH, BUT INCLUDING ANY MISMATCH BETWEEN THE TOP AND BOTTOM OF THE PLASTIC BODY..
- DIMENSION “b” DOES NOT INCLUDE DAMBAR PROTRUSION.  
ALLOWABLE DAMBAR PROTRUSION SHALL BE 0.08mm TOTAL IN EXCESS OF THE “b” DIMENSION AT MAXIMUM MATERIAL CONDITION. THE DAMBAR CANNOT BE LOCATED ON THE LOWER RADIUS OF THE FOOT . MINMUM SPACE BETWEEN PROTRUSION AND AN ADJACENT LEAD SHALL NOT BE LESS THAN 0.07mm
- LEAD FRAME MATERIAL:EFTEC 64T

### SOT-89 Package Information

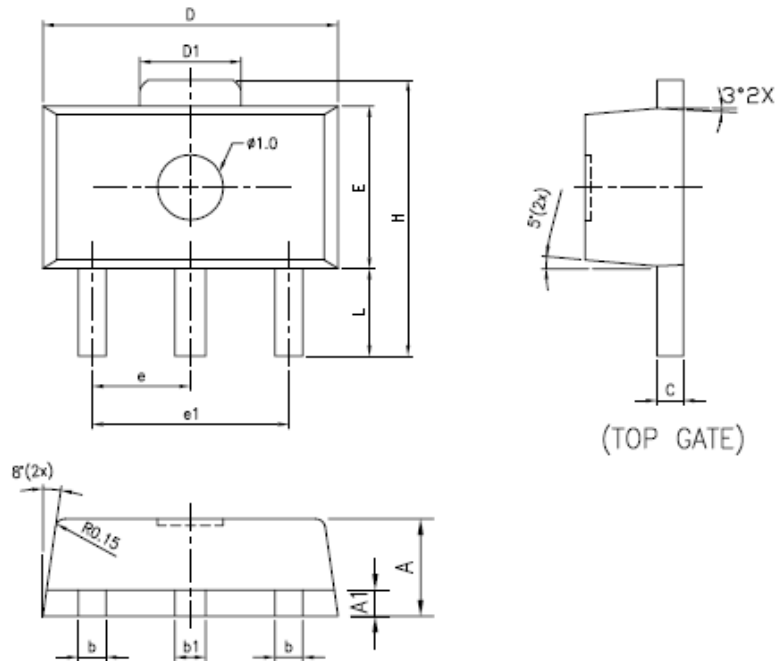

SYMBOLS	DIMENSIONS IN MILLIMETERS			DIMENSIONS IN INCHES		
	MIN	NOM	MAX	MIN	NOM	MAX
A	1.40	1.50	1.60	0.055	0.059	0.063
A1	0.30	0.40	0.50	0.011	0.015	0.019
L	0.80	—	1.20	0.031	—	0.047
b	0.36	0.42	0.48	0.014	0.016	0.018
b1	0.41	0.47	0.53	0.016	0.018	0.020
C	0.38	0.40	0.43	0.014	0.015	0.017
D	4.40	4.50	4.60	0.173	0.177	0.181
D1	1.40	1.60	1.75	0.055	0.062	0.069
H	3.94	—	4.25	0.155	—	0.167
E	2.40	2.50	2.60	0.094	0.098	0.102
e1	2.90	3.00	3.10	0.114	0.118	0.122
e	1.45	1.50	1.55	0.057	0.059	0.061

NOTES:

1. CONTROLLING DIMENSION : mm