



VT1712

E-N-V-Y 24

PCI Multi-Channel Audio Controller

Revision 2.4
May 28, 2002

VIA Technologies, Inc.

Copyright Notice:

Copyright © 2002 VIA Technologies Incorporated. All Rights Reserved. No part of this document may be reproduced, transmitted, transcribed, stored in a retrieval system, or translated into any language, in any form or by any means, electronic, mechanical, magnetic, optical, chemical, manual or otherwise without the prior written permission of VIA Technologies Incorporated. The material in this document is for information only and is subject to change without notice. VIA Technologies Incorporated reserves the right to make changes in the product design without reservation and without notice to its users.

Trademark Notices:

VT1712 and VT1724 may only be used to identify products of VIA Technologies.

Windows XP™, Windows 2000™, Windows ME™, Windows 98™, Windows 95™ and Plug and Play™ are registered trademarks of Microsoft Corp.

PCI™ is a registered trademark of the PCI Special Interest Group.

All trademarks are the properties of their respective owners.

Disclaimer Notice:

No license is granted, implied or otherwise, under any patent or patent rights of VIA Technologies. VIA Technologies makes no warranties, implied or otherwise, in regard to this document and to the products described in this document. The information provided by this document is believed to be accurate and reliable to the publication date of this document. However, VIA Technologies assumes no responsibility for any errors in this document. Furthermore, VIA Technologies assumes no responsibility for the use or misuse of the information in this document and for any patent infringements that may arise from the use of this document. The information and product specifications within this document are subject to change at any time, without notice and without obligation to notify any person of such change.

Offices:

USA Office:

940 Mission Court
Fremont, CA 94539
USA
Tel: (510) 683-3300
Fax: (510) 683-3301 or (510) 687-4654
Web: <http://www.viatech.com>

Taipei Office:

8th Floor, No. 533
Chung-Cheng Road, Hsin-Tien
Taipei, Taiwan ROC
Tel: (886-2) 2218-5452
Fax: (886-2) 2218-5453
Web: <http://www.via.com.tw>

Ordering Information:

VT1712 - 128PQFP

Revision History

Document Release	Date	Revision	Initials
1.1 (engg samples)		ICE1712 Data Sheet published by IC Ensemble, Inc.	RD
2.0 (production)		Reflect all the changes, including architectural ones for the production part Update Block Diag. in Fig. 4-1 Add VSR (ICE1232) support on Consumer AC-link path. CCS09_1 and _0 controls for each direction. Professional section I ² S clocking scheme enhancement MT01 and MT02 to support 64 and 88.2kHz. 256x and 128x MCLK global options. Appendix, Table 7-2 to reflect above. Add signal routing option of monitor to consumer section, via MT3C_0 bit (definition modified) Cleanup typos: CCI06 and CCI08 content swap location.	
2.1		Misc updates	RD
2.2	1/3/00	Remove Confidential notice Update MT3B mixer volume update rate, patchbay, and digital mixer insertion delay descriptions Fix typo on power-up default PCI06; Update Fig 4-3	RD
2.3	5/24/02	IC Ensemble, Inc. bought by VIA Technologies, product part number changed to VT1712 and document converted to VIA standard data sheet format	DH
2.4	5/28/02	Cleaned up typographical errors and fixed formatting issues	DH

Table of Contents

Revision History	i
Table of Contents	ii
List of Figures	vi
List of Tables	vii
Product Features	1-1
1.1 Product Applications	1-1
Overview	1-2
Pinouts	2-1
2.1 Pinout Diagram	2-2
2.2 Pin Descriptions	2-3
2.3 Pin Lists	2-6
PCI Interface and Configuration Registers	3-1
3.1 PCI Configuration Registers	3-2
<i>PCI00: Vendor Identification</i>	3-2
<i>PCI02: Device Identification</i>	3-2
<i>PCI04: PCI Command</i>	3-2
<i>PCI06: PCI Status</i>	3-3
<i>PCI08: Revision ID</i>	3-3
<i>PCI0A: Class Code</i>	3-3
<i>PCI0C: Cache Size</i>	3-4
<i>PCI0D: Latency Timer</i>	3-4
<i>PCI0E: Header Type</i>	3-4
<i>PCI0F: BIST</i>	3-4
<i>PCI10: Envy24 I/O Base</i>	3-4
<i>PCI14: DDMA I/O Base</i>	3-5
<i>PCI18: DMA Path Registers I/O Base</i>	3-5
<i>PCI1C: Multi-Track I/O Base</i>	3-5
<i>PCI2C: Sub-Vendor ID</i>	3-5
<i>PCI34: Capability Pointer</i>	3-6
<i>PCI34: Interrupt Pin and Line</i>	3-6

<i>PCI3E: Latency and Grant</i>	3-6
<i>PCI40: Legacy Audio Control</i>	3-7
<i>PCI42: Legacy Configuration Control</i>	3-8
<i>PCI60: System Configuration</i>	3-9
<i>PCI61: AC-Link Configuration</i>	3-9
<i>PCI62: I²S Converters Features</i>	3-10
<i>PCI63: S/PDIF Configuration</i>	3-10
<i>PCI80: Capability ID</i>	3-10
<i>PCI81: Next Item Pointer</i>	3-10
<i>PCI82: Power Management Capabilities</i>	3-11
<i>PCI84: Power Management Control / Status</i>	3-11
<i>PCI86: Power Management Control / Status (PMCSR) Base and Data</i>	3-11

Hardware Interfaces & Interface Registers

4.1 Controller Registers

<i>CCS00: Control / Status</i>	4-3
<i>CCS01: Interrupt Mask</i>	4-4
<i>CCS02: Interrupt Status</i>	4-4
<i>CCS03: Envy24 Index</i>	4-5
<i>CCS04: Envy24 Data</i>	4-5
<i>CCS05: NMI Status 1</i>	4-6
<i>CCS06: NMI Data</i>	4-6
<i>CCS07: NMI Index</i>	4-6
<i>CCS08: Consumer AC'97 Index</i>	4-7
<i>CCS09: Consumer AC'97 Command and Status</i>	4-7
<i>CCS0A: Consumer AC'97 Data Port</i>	4-7
<i>CCS0C: Primary MIDI UART Data</i>	4-8
<i>CCS0D: Primary MIDI UART Command / Status</i>	4-8
<i>CCS0E: NMI Status 2</i>	4-8
<i>CCS0F: Game Port</i>	4-8
<i>CCS10: I²C Port Device Address</i>	4-9
<i>CCS11: I²C Port Byte Address</i>	4-9
<i>CCS12: I²C Port Read / Write Data</i>	4-9
<i>CCS13: I²C Port Control and Status</i>	4-9
<i>CCS14: Consumer Record DMA Current / Base Address</i>	4-10
<i>CCS18: Consumer Record DMA Current / Base Count</i>	4-10
<i>CCS1B: PCI Configuration SERR# Shadow</i>	4-11
<i>CCS1C: Secondary MIDI UART Data</i>	4-11
<i>CCS1D: Secondary MIDI UART Command / Status</i>	4-11
<i>CCS1E: Timer</i>	4-11

4.2 Controller Indexed Registers

<i>CCI00: Playback Terminal Count (High Byte)</i>	4-12
<i>CCI01: Playback Terminal Count (Low Byte)</i>	4-12
<i>CCI02: Playback Control</i>	4-12
<i>CCI03: Playback Left Volume / Pan</i>	4-13
<i>CCI04: Playback Right Volume / Pan</i>	4-13
<i>CCI05: Soft Volume / Mute Control</i>	4-13

<i>CCI06: Playback Sampling Rate (Low Byte)</i>	4-14
<i>CCI07: Playback Sampling Rate (Middle Byte)</i>	4-14
<i>CCI08: Playback Sampling Rate (High Byte)</i>	4-14
<i>CCI10: Record Current / Base Terminal Count (High Byte)</i>	4-14
<i>CCI11: Record Current / Base Terminal Count (Low Byte)</i>	4-15
<i>CCI12: Record Control</i>	4-15
<i>CCI20: GPIO Data</i>	4-16
<i>CCI21: GPIO Write Mask</i>	4-16
<i>CCI22: GPIO Direction Control</i>	4-16
<i>CCI30: Consumer Section Power Down</i>	4-17
<i>CCI31: Multi-Track Section Power Down</i>	4-17
4.3 DDMA Registers	4-18
4.4 DMA Path Descriptions	4-19
4.5 Consumer Section DMA Channel Registers	4-20
<i>DS0: DirectSound DMA Interrupt Mask</i>	4-20
<i>DS2: DirectSound DMA Interrupt Status</i>	4-20
<i>DS4: Channel Data</i>	4-21
<i>DS8: Channel Index</i>	4-21
<i>Channel Control and Status at Index 4h (DS8 = x4h)</i>	4-22
<i>Consumer Mode Sampling Rate at Index 5h (DS8 = x5h)</i>	4-22
<i>Consumer Mode Left / Right Volume at Index 06h (DS8 = x6h)</i>	4-23
4.6 Professional Multi-Track Control Registers	4-24
4.6.1 Multi-Track Mode Control Registers	4-24
<i>MT00: Professional Section DMA Interrupt Mask and Status</i>	4-24
<i>MT01: Professional Section Sampling Rate Select</i>	4-25
<i>MT02: Professional Section AC'97 Codec I²S Data Format</i>	4-26
<i>MT04: Professional Section AC'97 Codec Index</i>	4-26
<i>MT05: Professional Section AC'97 Codec Command / Status</i>	4-29
<i>MT06: Professional Section AC'97 Codec Data Port</i>	4-29
4.6.2 Multi-Track Playback Registers	4-30
<i>MT10: Professional Section Playback DMA Current / Base Address</i>	4-30
<i>MT14: Professional Section Playback DMA Current / Base Count</i>	4-31
<i>MT16: Professional Section Playback Current / Base Terminal Count</i>	4-31
<i>MT18: Professional Section Playback and Record Control</i>	4-31
4.6.3 Multi-Track Record Registers	4-32
<i>MT20: Professional Section Record DMA Current / Base Address</i>	4-32
<i>MT24: Professional Section Record DMA Current / Base Count</i>	4-32
<i>MT26: Professional Section Record Current / Base Terminal Count</i>	4-32
<i>MT28: Professional Section Record Control</i>	4-32
4.6.4 Professional Section Digital Loopback	4-33
<i>MT30: Routing Control for Data to PSDOUT[0:3]</i>	4-34
<i>MT32: Routing Control for SPDOUT</i>	4-35
<i>MT34: Captured (Recorded) Data Routing Selection</i>	4-36
4.6.5 Multi-Track Digital Monitoring	4-39

<i>MT38: Left / Right Volume Control Data</i>	4-39
<i>MT3A: Volume Control Stream Index</i>	4-40
<i>MT3B: Volume Control Rate</i>	4-40
<i>MT3C: Digital Mixer Monitor Routing Control</i>	4-41
<i>MT3E: Peak Meter Index</i>	4-42
<i>MT3F: Peak Meter Data</i>	4-42
Electrical Specifications	5-1
5.1 Maximum Ratings	5-1
5.2 Electrical Specifications	5-1
5.3 AC Timing Characteristics	5-2
Mechanical Specifications	6-1
6.1 Thermal Specifications	6-1
6.2 Package Dimensions	6-2
Appendix A	A-1
A.1 Appendix A	A-1

List of Figures

Figure 2-1.	128-Pin PQFP Package	2-2
Figure 4-1.	Functional Block Diagram	4-2
Figure 4-2.	I ² S Format Timing Diagram	4-26
Figure 4-3.	Crystals to Master Clocks Clock Generation Tree	4-27
Figure 4-4.	Master Clocks to Bit Clocks, L/R Clocks and Sync Generation	4-28
Figure 4-5.	Multi-Track DMA Transfer	4-30
Figure 4-6.	Data Stream Routing Capabilities	4-33
Figure 4-7.	Digital Mixer Functional Diagram	4-41
Figure 5-1.	Cold Reset Timing	5-2
Figure 5-2.	Warm Reset Timing	5-3
Figure 5-3.	Master Clock Delay	5-3
Figure 5-4.	xBCLK to xxSYNC Timing	5-4
Figure 5-5.	Setup and Hold Time	5-5
Figure 5-6.	Rise Time and Fall Time	5-6
Figure 5-7.	AC-Link Power Mode Timing	5-6

List of Tables

Table 2-1.	Pin Descriptions	2-3
Table 2-2.	Alphabetical Pin Listing	2-6
Table 2-3.	Numerical Pin Listing	2-7
Table 3-1.	PCI Host Interface Register Map	3-1
Table 4-2.	CCSxx Controller Register Map	4-3
Table 4-3.	DMA Channels and Respective Functionality	4-19
Table 4-4.	DSx Consumer DMA Channel Register Map	4-20
Table 4-5.	DS8 Register, Low Nibble Index Description Applicable to Channel-0 through D	4-21
Table 4-6.	Channel Parameter Controls.	4-23
Table 4-7.	MTxx Controller Register Map	4-24
Table 5-2.	DC Characteristics	5-1
Table 5-1.	Maximum Ratings	5-1
Table 5-3.	Power Consumption	5-2
Table 5-4.	Cold Reset	5-2
Table 5-5.	Warm Reset	5-3
Table 5-6.	Slave Mode Master clock delay	5-3
Table 5-7.	xBCLK / xxSYNC Timing.	5-4
Table 5-8.	Setup and Hold.	5-5
Table 5-9.	Rise and Fall Time	5-5
Table 5-10.	AC-Link Low Power Mode	5-6
Table 6-1.	Mechanical Dimensions	6-2
Table A-1.	AC-Link Interface Parameters and Ratios (Pin 50 Floating / Pulled Up)	A-1
Table A-2.	I ² S Interface Parameters and Ratios (Pin 50 Pulled Down)	A-1
Table A-3.	S/PDIF Output I ² S Interface Parameters and Ratios	A-2
Table A-4.	S/PDIF Input I ² S Interface Parameters and Ratios.	A-2

VT1712

Envy24™

PCI Multi-Channel Audio Controller

Product Features

- PCI 2.1 I/F with bus mastering and burst modes
- 24-bit resolution audio format support
- Sampling rates up to 96kHz
- 8x2 I/O on AC-link or I²S, up to 4x2 converters
- Simultaneous I²S for S/PDIF I/O up to 96kHz
- 20 channels, 36-bit wide digital mixer
- Monitor and master copy functions
- Peak meters on all 20 professional multi-track streams
- Concurrent 16 streams DirectSound™ accelerator
- Sample Rate Converter for DirectSound applications
- Two MPU-401 MIDI UART ports
- ACPI and PCI PMI support
- I²C subset I/F for E²PROM (configuration and ID storage) and peripherals control
- HW SoundBlaster® Pro legacy
- FM synthesis for DOS® legacy
- 64-voices SW Wavetable General MIDI Synthesizer for Windows95
- DirectInput™ compatible Joystick port
- 8-bit GPIO port
- Windows® 95/98, NT4.0 drivers
- 24.576, 16.9344 or 22.5792 MHz crystal operation
- 3.3V operating supply (5V tolerant I/O)
- 128-pin PQFP (14mm x 20mm body)

1.1 Product Applications

- PC-based multi-track audio
- Discrete multi-channel audio
- High-end PCI audio
- “Pro-sumer” audio
- General purpose multi-channel I/O
- Computer telephony
- PC-based data acquisition
- PC-based waveform generation
- PC-based instrumentation
- PC-based control and automation

Overview

The Envy24™ is a versatile PCI multi-channel I/O controller. It allows up to 12x2 simultaneous input and output channels with the data source or destination being either analog or digital. Some of the typical applications for this part are computer based multi-track audio, multi-channel audio, PC-based data acquisition, waveform generation and computer telephony integration. The Envy24 can be combined with professional grade I²S converters, S/PDIF transmitters/receivers or AC-link codecs, such as the VT1611A™. The controller integrates a very high resolution digital mixer allowing up to 20 channels of mixing. This is aimed specifically for monitoring final outputs, making master copies and for budget conscious studios that may lack an individual out-board mixer.

The Envy24 supplies a master I²C interface providing connection to an E²PROM to store and retrieve PCI Subsystem and Subsystem vendor IDs, specific board configurations and custom features identification. This interface is available for controlling other devices as well.

For target markets where legacy audio is still important, the SoundBlaster Pro compatible hardware ensures hardware compatibility under DOS for DDMA (Distributed DMA) and non-DDMA systems. The device also includes a Microsoft Win9x architecture based DirectSound hardware accelerator that interfaces to AC'97 via AC-link. The separate path allows concurrent operation with the 24-bit professional multi-track audio section.

The Envy24 is a “Digital-Ready” audio device allowing acceleration in cooperation with the host and redirecting audio streams to other endpoints.

The Envy24 integrates two independent MPU-401 MIDI UARTs. This features allows hooking up multiple external MIDI devices and dedicating the two paths for different purposes.

Additionally, a conventional standard Joystick port and timer is integrated. Only R and C components are necessary to complete the circuit. Also an 8-bit GPIO brings flexibility for multi-purpose use.

The Envy24 is a power miser device due to its aggressive power management scheme and hard-wired design architecture. The device is ACPI compliant making it suitable for platforms designed for “OnNow”.

Depending on the sampling rates that need to be supported by the target solution, one or two crystals are sufficient to operate the whole system. Alternatively, a PLL Clock synthesizer chip can be used to generate the necessary frequencies. The clock chip can be controlled by the GPIO pins for programmability.

For more detail on the part, please refer to the system block diagram Figure 4-1 in Section 4.

Pinouts

The following section includes the pinout diagram of the chip that is housed in a standard 128-PQFP. Also, three lists of pin assignments are provided for your convenience. They are logically sorted by functionality and description, alphabetically and numerically sorted in ascending order. These list are provided to assist hardware development, test, debugging and quality assurance. The mechanical data about the part can be found in Section 6.

2.1 Pinout Diagram

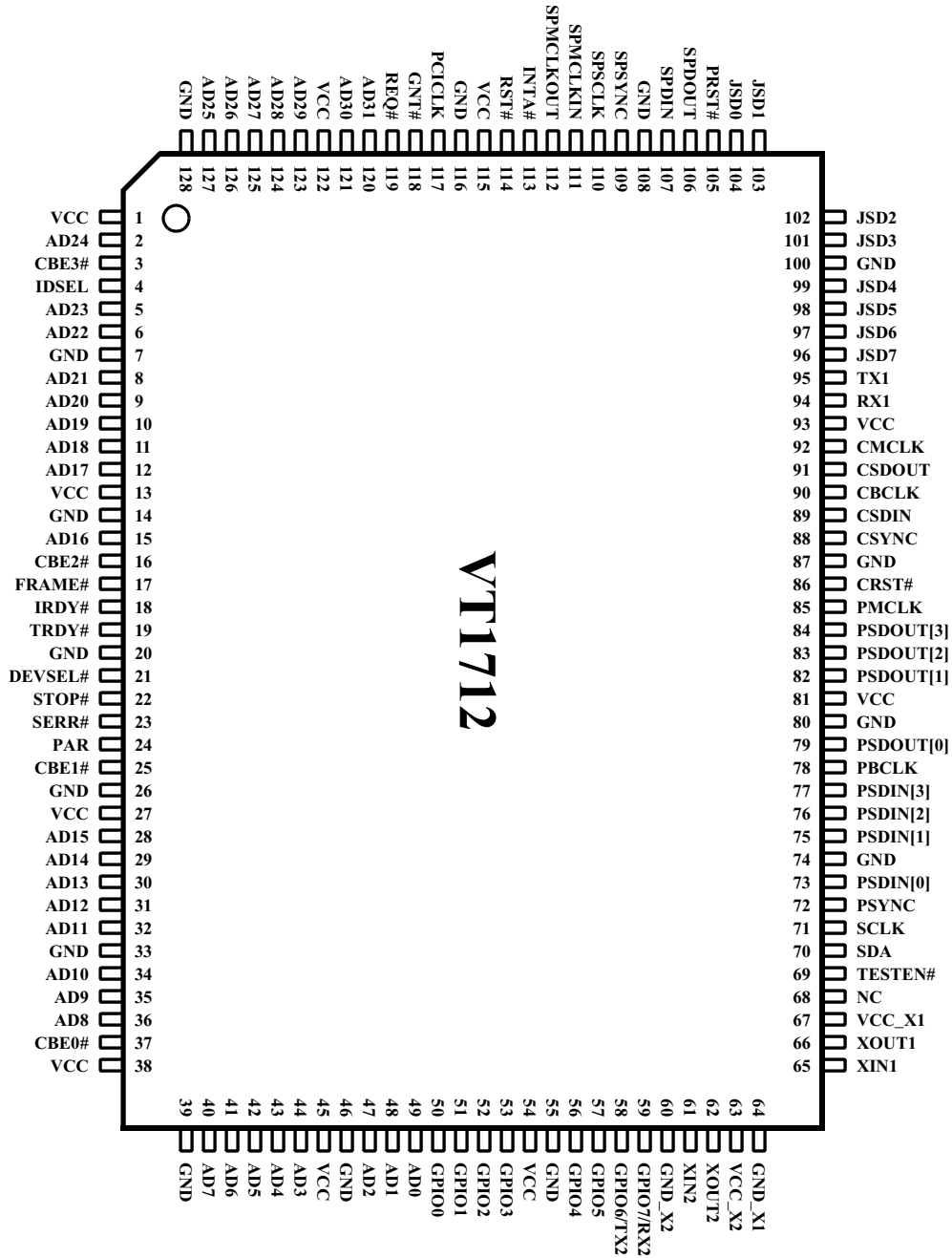

Figure 2-1. 128-Pin PQFP Package

2.2 Pin Descriptions

The following table provides a brief description of each pin of the VT1712. Pins with dual usage may be listed twice for consistency.

The following abbreviations are used to identify the pin types.

I - Input Signal
 O - Output Signal
 B - Bidirectional Signal
 OD - Open Drain
 A - Analog Signal
 PU - Pull-up. 50 K Ω nominal

Table 2-1. Pin Descriptions

PCI Bus Interface		
Symbol	Type	Description
AD[31:0]	B	Multiplexed PCI Address / Data Bus.
CBE#[3:0]	B	Bus Command / Byte Lane Enable. These signals are bus commands during the address phase and byte lane enable during the data phase. These signals are output during a bus master cycle.
PCICLK	I	PCI Bus Clock.
DEVSEL#	B	Device Select. The VT1712 drives this signal active when it decodes its address as the current target of the current access.
FRAME#	B	PCI Cycle Frame. When asserted by the bus master, this signal indicates the beginning of a bus transaction. During the final data phase of a bus transaction it is deasserted.
GNT#	I	PCI Bus Grant. When active it indicates bus master is granted to VT1712.
IDSEL	I	Initialization Device Select. This is the chip select during the PCI configuration register accesses
INTA#	OD	PCI Interrupt Request.
IRDY#	B	Initiator Ready.
PAR	B	Parity Signal.
REQ#	O	Bus Master Control Request
RST#	I	System Reset. All VT1712 registers and state machines are at default when this signal is asserted.
SERR#	OD	PCI System Error.
STOP#	B	Target Disconnect.
TRDY#	B	Target Ready.
I ² C Port		
SDA	B	Serial Data.
SCLK	O	Serial Bit Shift Clock.
Game Port		
JSD[7:4]	I	Joystick Fire Buttons.
JSD[3:0]	A	Joystick Coordinates Inputs.
Primary MPU-401 UART		
TX1	O, PU	Primary MPU-401 Transmit Data.
RX1	I, PU	Primary MPU-401 Receive Data.

Table 2-1. Pin Descriptions (continued)

Secondary MPU-401 UART		
TX2 / GPIO6	O	Secondary MPU-401 Transmit Data.
RX2 / GPIO7	I	Secondary MPU-401 Receive Data.
Consumer AC-Link Interface		
CSYNC	O	48kHz fixed rate sync pulse
CBCLK	I	12.288MHz Serial Bit Clock
CSDIN	I	Incoming Serial Data Stream
CSDOUT	O	Outbound Serial Data Stream
CMCLK	O	Master Clock for AC'97 codec. Outputs XIN1 crystal frequency, typically 24.576 MHz .
CRST#	O	Consumer Codec master reset
Professional Multi-Track AC-Link / I²S Interface		
PSYNC	O	AC'97: 48kHz fixed rate sync pulse for up to 4 codecs, or 8 I ² S type converters: Left/Right Clock
PBCLK	I/O	Serial Bit Clock. It can be master or slave configured
PSDIN[3:0]	I	4 separate incoming stereo stream pairs
PSDOUT[3:0]	O	4 separate outbound stereo stream pairs
PMCLK	O	Master Clock for AC'97 codecs or I ² S converters
PRST#	O	Cold reset for Professional Multi-track I ² S/AC-link I/F
Clocks		
XOUT1	A	Clock Out 1.
XIN1	A	Clock In 1. 24.576 MHz (512*48 KHz). Runs all fixed clock blocks.
XOUT2	A	Clock Out 2.
XIN2	A	Clock In 2. 16.9344 MHz (384*44.1 KHz) or 22.5792 MHz (512*44.1 KHz) or external PLL output
S/PDIF (Sony / Philips Digital Interface)		
SPMCLKIN	I	S/PDIF Master Clock Input.
SPMCLKOUT	O	S/PDIF Master Clock Output.
SPSCLK	O	S/PDIF Serial Bit Clock.
SPDIN	I	Incoming S/PDIF Serial Data.
SPDOUT	O	Outbound S/PDIF Serial Data.
SPSYNC	O	S/PDIF Frame Sync.
General Purpose I/O		
Symbol	Type	Description
GPIO7 / RX2	B, PU	General Purpose I/O. Secondary MPU-401 Receive data
GPIO6 / TX2	B, PU	General Purpose I/O. Secondary MPU-401 Transmit data
GPIO5 / S1	B, PU	General Purpose I/O. Clock rate select for external clock chip select
GPIO4 / S0	B, PU	General Purpose I/O. Clock rate select for external clock chip select
GPIO3 / E²PROM	B, PU	General Purpose I/O. E ² PROM presence indicator during power-up (default). The state is reflected on CCS13[7] bit.

Table 2-1. Pin Descriptions (continued)

GPIO2	B, PU	General Purpose I/O.
GPIO1	B, PU	General Purpose I/O.
GPIO0 / PS#	B, PU	General Purpose I/O. Sets AC-link interface for professional section during power-up (default). The state is reflected on PCI61[7] bit in reverse polarity.
Test Mode		
TESTEN#	I, PU	Test Mode Enable. Do not connect for normal operation.
Power and Ground		
VCC		Digital Supply Voltage. 3.3V
GND		Ground.

2.3 Pin Lists

Table 2-2 lists all the pins alphabetically. **Table 2-3** lists all the pins in numerical order.

Table 2-2. Alphabetical Pin Listing

Symbol	Pin(s)	Symbol	Pin(s)
AD[31:0]	2, 5-6, 8-12, 15, 28-32, 34-36, 40-44, 47-49, 120-121, 123-127,	PMCLK	85
CBCLK	90	PRST#	105
CBE#[3:0]	3, 16, 25, 37	PSDIN[3:0]	73, 75-77
CMCLK	92	PSDOUT[3:0]	79, 82-84
CRST#	86	PSYNC	72
CSDIN	89	REQ#	119
CSDOUT	91	RST#	114
CSYNC	88	RX1	94
DEVSEL#	21	RX2 / GPIO[7]	59
FRAME#	17	SCLK	71
GND	7, 14, 20, 26, 33, 39, 46, 55, 74, 80, 87, 100, 108, 116, 128	SDA	70
GND_X1	64	SPDIN	107
GND_X2	60	SPDOUT	106
GNT#	118	SERR#	23
GPIO[0] / I ² S#	50	SPMCLKIN	111
GPIO[1]	51	SPMCLKOUT	112
GPIO[2]	52	SPSCLK	110
GPIO[3] / E ² PROM	53	SPSYNC	109
GPIO[4]/S0	56	STOP#	22
GPIO[5]/S1	57	TESTEN#	69
GPIO[6] / TX2	58	TRDY#	19
GPIO[7] / RX2	59	TX1	95
IDSEL	4	TX2 / GPIO[6]	58
INTA#	113	VCC	1, 13, 27, 38, 45, 54, 81, 115, 122
IRDY#	19	VCC_X1	67
JSD[7:0]	96-99, 101-104	VCC_X2	63
PAR	24	XIN[2:1]	61, 65
PBCLK	78	XOUT[2:1]	62, 66
PCICLK	117		

Table 2-3. Numerical Pin Listing

Pin #	Symbol	Pin #	Symbol	Pin #	Symbol	Pin #	Symbol
1	VCC	33	GND	65	XOUT1	97	JSD6
2	AD24	34	AD10	66	VCC_X1	98	JSD5
3	CBE3#	35	AD9	67	VCC	99	JSD4
4	IDSEL	36	AD8	68	GND	100	GND
5	AD23	37	CBE0#	69	TESTEN#	101	JSD3
6	AD22	38	VCC	70	SDA	102	JSD2
7	GND	39	GND	71	SCLK	103	JSD1
8	AD21	40	AD7	72	PSYNC	104	JSD0
9	AD20	41	AD6	73	PSDIN[0]	105	TX2
10	AD19	42	AD5	74	GND	106	SPDOUT
11	AD18	43	AD4	75	PSDIN[1]	107	SPDIN
12	AD17	44	AD3	76	PSDIN[2]	108	VCC
13	VCC	45	VCC	77	PSDIN[3]	109	SPSYNC
14	GND	46	GND	78	PBCLK	110	SPSCLK
15	AD16	47	AD2	79	PSDOUT[0]	111	SPMCLKIN
16	CBE2#	48	AD1	80	GND	112	SPMCLKOUT
17	FRAME#	49	AD0	81	VCC	113	INTA#
18	IRDY#	50	GPIO[0]	82	PSDOUT[1]	114	RST#
19	TRDY#	51	GPIO[1]	83	PSDOUT[2]	115	VCC
20	GND	52	GPIO[2]	84	PSDOUT[3]	116	GND
21	DEVSEL#	53	GPIO[3]	85	PMCLK	117	PCICLK
22	STOP#	54	VCC	86	CRST#	118	GNT#
23	SERR#	55	GPIO[4] / S0	87	GND	119	REQ#
24	PAR	56	GPIO[5] / S1	88	CSYNC	120	AD31
25	CBE1#	57	GPIO[6] / TX2	89	CSDIN	121	AD30
26	GND	58	GPIO[7] / RX2	90	CBCLK	122	VCC
27	VCC	59	GND_X2	91	CSDOUT	123	AD29
28	AD15	60	XIN2	92	CMCLK	124	AD28
29	AD14	61	XOUT2	93	VCC	125	AD27
30	AD13	62	VCC_X2	94	RX1	126	AD26
31	AD12	63	GND_X1	95	TX1	127	AD25
32	AD11	64	XIN1	96	JSD7	128	GND

PCI Interface and Configuration Registers

Table 3-1. PCI Host Interface Register Map

Byte 3	Byte 2	Byte 1	Byte 0	Offset (Hex)
Device Identification		Vendor Identification		00
PCI Device Status		PCI Command		04
Class Code		Reserved. Read as 0	Revision ID	08
BIST	Header Type	Latency Timer	Reserved. Read as 0	0C
Controller I/O Base Address				10
DDMA I/O Base Address				14
DMA Path Registers I/O Base Address				18
Professional Multi-Track I/O Base Address				1C
Subsystem ID		Subsystem Vendor ID		2C
Reserved. Read as 0				30
Capability Pointer				34
Reserved. Read as 0				38
Minimum Latency and Maximum Grant		Interrupt Pin and Line		3C
Legacy Configuration Control		Legacy Audio Control		40
Hardware Configuration Control				60
Power Management Capability		Next Item Pointer	Capability ID	80
PMCSR Support Extensions and Data		Power Management Control and Status		84

3.1 PCI Configuration Registers

PCI00: Vendor Identification

Address Offset: 00 - 01h

Default Value: 1412h

Bit	Attribute	Description
15:0	RO	Vendor Identification Number. 16-bit value assigned to VIA Technologies, Inc.

PCI02: Device Identification

Address Offset: 02 - 03h

Default Value: 1712h

Bit	Attribute	Description
15:0	RO	Device Identification Number. 1712 reflects the part number.

PCI04: PCI Command

Address Offset: 04 - 05h

Default Value: 0000h

Bit	Attribute	Description
15:10	R0b	Reserved. Read as 0s.
9	R0b	Fast Back-to-Back Enable. This bit is hardwired to 0 (Not Implemented).
8	R/W	SERR# enable. 1=enable. 0=disable (default). When enabled, FM and MIDI I/O writes will be trapped and causes SERR# asserted. PCISTS register reports the status of the SERR# signal. This bit has a shadow defined in register bit CCS1B_0.
7	R0b	A/D stepping enable. This bit is hardwired to 0 (Not Implemented).
6	R0b	Parity error detect enable. Hardwired to 0 (Not Implemented).
5	R0b	VGA palette snoop enable. Hardwired to 0 (Not Implemented).
4	R0b	Memory write and invalidate enable. Hardwired to 0 (Not Implemented).
3	R0b	Special Cycle Enable (SCE). Hardwired to 0 (Not Implemented).
2	R/W	Bus master enable. 1=enable. 0=disable (default).
1	R0b	Memory Access. Hardwired to 0 (Not Implemented).
0	R/W	I/O Space accesses enable. 1=enable. 0=disable (default).

PCI06: PCI Status

Address Offset: 06 - 07h

Default Value: 0210h

Bit	Attribute	Description
15	R/W/C	PAR status. Parity error detected (even when parity not enabled).
14	R/W/C	SERR# status. This bit is set to 1 when SERR# is asserted (even when it is not enabled) and cleared by writing 1 to it.
13	R/W/C	Master abort status. This bit is set to 1 when master aborts and cleared by writing "1" to it.
12	R/W/C	Received target abort status. This bit is set to 1 when target abort is received and cleared by writing a 1 to it.
11	R0b	Signaled target abort status. This bit is set when target abort generated and cleared by writing a 1 to it. Hardwired to 0 (never abort).
10:9	R10b	DEVSEL# timing status. Envy24 always asserts DEVSEL# with medium timing.
8	R0b	PERR# response. Read as 0 (Not Implemented).
7	R0b	Fast back to back. Read as 0 (Not implemented).
6	R0b	User Define Function (UDF). Read as 0 (Not implemented).
5	R0b	Reserved. Read as 0. 33MHz only.
4	R1b	Hardwired to 1 to indicate the support for PCI power management capability.
3:0	R0000b	Reserved. Read as 0s.

PCI08: Revision ID

Address Offset: 08h - 09h

Default Value: 000Xh

Bit	Attribute	Description
15:0	R00h	-
7:0	RO	Revision ID

PCI0A: Class Code

Address Offset: 0Ah - 0Bh

Default Value: 0401h

Bit	Attribute	Description
15:8	RO	Base Class. Reflects Multimedia
7:0	RO	Sub class. Reflects Audio.

PCI0C: Cache Size

Address Offset: 0Ch

Default Value: 00h

Bit	Attribute	Description
7:0	RO	Read as 0. Not supported

PCI0D: Latency Timer

Address Offset: 0Dh

Default Value: 00h

Bit	Attribute	Description
7:3	R/W	Latency timer
2:0	RO	Read as 0

PCI0E: Header Type

Address Offset: 0Eh

Default Value: 00h

Bit	Attribute	Description
7:0	RO	Read as 0

PCI0F: BIST

Address Offset: 0Fh

Default Value: 00h

Bit	Attribute	Description
7:0	RO	Read as 0. Not supported

PCI10: Envy24 I/O Base

Address Offset: 10h - 13h

Default Value: 00000001h

Bit	Attribute	Description
31:5	RW	Controller I/O Base Address for CCSxx registers described in section 4.1
4:1	R0h	Hardwired to 0 to have 32 bytes I/O space. This includes UARTs and game port.
0	R1b	Hardwired to 1 to indicate registers map to I/O space

PCI14: DDMA I/O Base

Address Offset: 14h -17h

Default Value: 00000001h

Bit	Attribute	Description
31:4	R/W	DDMA Slave Channel Base Address for DDMAx registers described in section 4.2
3:1	R000b	Hardwired to 0 to have 16 bytes I/O space
0	R1b	Hardwired to 1 to indicate registers map to I/O space

PCI18: DMA Path Registers I/O Base

Address Offset: 18h - 1Bh

Default Value: 00000001h

Bit	Attribute	Description
31:4	R/W	DMA path registers I/O Base Address for DSx registers described in section 4.4
3:1	R000b	Hardwired to 0 to specify requirement of 16 bytes I/O space
0	R1b	Hardwired to 1 to indicate registers map to I/O space

PCI1C: Multi-Track I/O Base

Address Offset: 1Ch - 1Fh

Default Value: 00000001h

Bit	Attribute	Description
31:6	R/W	Multi-Track I/O Base Address for MTxx registers described in section 4.5
5:1	R0	Hardwired to 0 to have 64 bytes I/O space
0	R1b	Hardwired to 1 to indicate registers map to I/O space

PCI2C: Sub-Vendor ID

Address Offset: 2Ch - 2Fh

Default Value: 17121412h

Bit	Attribute	Description
31:0	RO	Sub-vendor ID: Read it from external E ² PROM after reset if it exists, otherwise, same as vendor ID. It can also be written by disabling write protection bit defined in PCI42_7.

PCI34: Capability Pointer

Address Offset: 34h

Default Value: 80h

Bit	Attribute	Description
7:0	RO	CP7-CP0: Capability data structure pointer for PCI power management. Hardwired to 80h.

PCI34: Interrupt Pin and Line

Address Offset: 3Ch - 3Dh

Default Value: 01FFh

Bit	Attribute	Description
15:8	RO	01h read from this register indicates the interrupt pin used is INTA# and cannot be modified.
7:0	R/W	Interrupt line routing information set by POST during power-up initialization. Default FFh indicates no connection to the PIC yet.

PCI3E: Latency and Grant

Address Offset: 3Eh - 3Fh

Default Value: 0000h

Bit	Attribute	Description
15:8	RO	Maximum latency
7:0	RO	Minimum grant

PCI40: Legacy Audio Control

Address Offset: 40h - 41h

Default Value: 807Fh

Bit	Attribute	Description
15	R/W	0: Legacy Audio Hardware enable. 1: Legacy Audio Hardware disabled (default)
14:12	R000b	-
11:10	R/W	Reserved
9:8	R/W	Reserved
7:6	R/W	SB DMA Channel Select: 00 DMA 0 01 DMA 1 (default) 10 Reserved 11 DMA 3
5	R/W	I/O Address Alias Control 1: select the 10-bit decode (default) 0: select the 16-bit decode In either case, the AD(31:16) should be zero
4	R/W	Reserved
3	R/W	MPU-401 I/O enable
2	R/W	Game Port enable (200h)
1	R/W	FM I/O enable (AdLib 388h base)
0	R/W	SB I/O enable

PCI42: Legacy Configuration Control

Address Offset: 42h - 43h

Default Value: 0006h

Bit	Attribute	Description
15:8	R/W	Interrupt vector to be snooped.
7	R/W	0: SVID read only. (default) 1: SVID read/write enable.
6	R/W	0: snoop SB 22C/24Ch I/O write cycle to assert SERR#: disable (default) 1: snoop SB 22C/24Ch I/O write cycle to assert SERR# : enable
5	R/W	0: snoop PIC I/O R/W cycle to assert SERR#: disable (default) 1: snoop PIC I/O R/W cycle to assert SERR#: enable
4	R/W	0: snoop PCI bus interrupt acknowledge cycle: disable (default) 1: snoop PCI bus interrupt acknowledge cycle: enable
3	R/W	0: SB base 220h (default) 1: SB base 240h
2:1	R/W	0: MPU-401 base 300h 1: MPU-401 base 310h 2: MPU-401 base 320h 3: MPU-401 base 330h (default)
0	RW	0: DDMA enable (default) 1: Legacy DMA enable

PCI160: System Configuration

Address Offset: 60h

Default Value: 0Fh

The following four bytes (60h-63h) should be read from E²PROM by driver and then written to setup the codec configuration, unless otherwise noted.

Bit	Attribute	Description
7:6	R/W	XIN2 Clock Source Configuration. Refer to register MT01 and Table A-2 in the Appendix 00: XIN2: 22.5792MHz crystal (44.1kHz*512) 01: XIN2: 16.9344MHz crystal (44.1kHz*384) 10: XIN2: from external clock synthesizer chip (e.g. MK1412) which needs to be controlled via S0, S1 pins. These shared GPIO4 and 5 pins become write only and the direction will not be controllable via CCI22. 11: - Reserved
5	R/W	0: one MPU-401 UART only 1: two MPU-401 UARTs.
4	R/W	Consumer AC'97 codec: 0: Consumer AC'97 does exist 1: Consumer AC'97 does not exist
3:2	R/W	Must have at least one pair of professional multi-track ADC and DAC. 00: one stereo ADC connected 01: two stereo ADCs connected 10: three stereo ADCs connected 11: four stereo ADCs connected
1:0	R/W	Must have at least one pair of professional multi-track ADC and DAC. 00: one stereo DAC connected 01: two stereo DACs connected 10: three stereo DACs connected 11: four stereo DACs connected

PCI161: AC-Link Configuration

Address Offset: 61h

Default Value: 00h

Except for bit 7, the four bytes at 60h-63h should be read from E²PROM by driver and then written to setup the codec configuration.

Bit	Attribute	Description
7	R/W	Multi-track converter type: 0: AC'97 1: I ² S. Reflects power-up status of pin 50 during reset cycle in reverse polarity. Can be overwritten
6:2	R/W	Reserved.
1	R/W	If bit 7 is 0: 0: split mode: AC'97 codec SDATA_OUT split to different pin outputs 1: packed mode: AC'97 codec SDATA_OUT packed in slots 3 to 10
0	R/W	If bit 7 is 0: 0: split mode: AC'97 code:SDATA_IN split from different pin inputs 1: packed mode: AC'97 codec SDATA_IN packed in slots 3 to 10

PCI62: I²S Converters Features

Address Offset: 62h

Default Value: 01h

This byte is valid only when PCI61_7 is 1. The four bytes at 60h-63h should be read from E²PROM by driver and then written to setup the codec configuration.

Bit	Attribute	Description
7	R/W	For I ² S codec Volume and mute 0: I ² S codec has no volume/mute control feature. 1: I ² S codec has volume/mute control capability and need to be program through GPIO (e.g., CS4222)
6	R/W	I ² S converter 96kHz sampling rate support. 0: does not; 1 : supports
5:4	R/W	Converter resolution: 00: 16-bit 01: 18-bit 10: 20-bit 11: 24-bit
3:0	R/W	Other I ² S IDs

PCI63: S/PDIF Configuration

Address Offset: 63h

Default Value: 03h

The four bytes at 60h-63h should be read from E²PROM by driver and then written to setup the codec configuration.

Bit	Attribute	Description
7:2	R/W	S/PDIF chip ID
1	R/W	1: S/PDIF Stereo In is present. Forces 64bpf on I ² S interface.
0	R/W	1: S/PDIF Stereo Out is present. Forces 64bpf on I ² S interface.

PCI80: Capability ID

Address Offset: 80h

Default Value: 01h

Bit	Attribute	Description
7:0	RO	Capability ID

PCI81: Next Item Pointer

Address Offset: 81h

Default Value: 00h

Bit	Attribute	Description
7:0	RO	Hardwired to 0 to indicate the end of list

PCI82: Power Management Capabilities

Address Offset: 82h - 83h

Default Value: 0401h

Bit	Attribute	Description
15:11	RO	PME not supported. Hardwired to 0.
10	R1	D2 state support. Hardwire to 1.
9	R0	D1 state not support. Hardwired to 0.
8:6	R000	Reserved.
5	R0	DSI. Hardwired to 0.
4	R0	Aux. Power. Hardwired to 0
3	R0	PMC clock for generation of PME#. Hardwired to 0.
2:0	R001b	Hardwired to 001 to indicate PPMI 1.0 compliance

PCI84: Power Management Control / Status

Address Offset: 84h - 85h

Default Value: 0000h

Bit	Attribute	Description
15	R0b	PME status. Read as 0.
14:13	R00b	Data scale. Not supported.
12:9	R0h	Data select: Not supported.
8	R0b	PME assertion. Hardwired to 0
7:2	RO	Hardwired to 000000
1:0	R/W	Power state. To determine the current state of power state. 00 : D0 01 : D1 (not supported) 10 : D2 11 : D3_hot

PCI86: Power Management Control / Status (PMCSR) Base and Data

Address Offset: 86h - 87h

Default Value: 0000h

Bit	Attribute	Description
15:0	R0000h	-

Hardware Interfaces & Interface Registers

In the previous section PCI host interface and configuration registers were discussed. In this section description of the major blocks, their respective hardware interfaces and associated registers will be discussed. In most cases the four I/O base addresses have a one to one correspondence with the major functional blocks. Therefore, the following sub-chapters will be organized based on the logical grouping of the registers on the offsets of their respective I/O base addresses.

The first figure in this section, **Figure 4-4-1**, is a chip level block diagram with typical external interface usage. It is a very good overview of the whole chip, but should not be regarded as the most detailed diagram. As appropriate, the databook will resort to sub-block diagrams to further detail the functionality. These are the multi-track DMA transfer mechanism, data stream routing capabilities and the digital mixer block diagram.

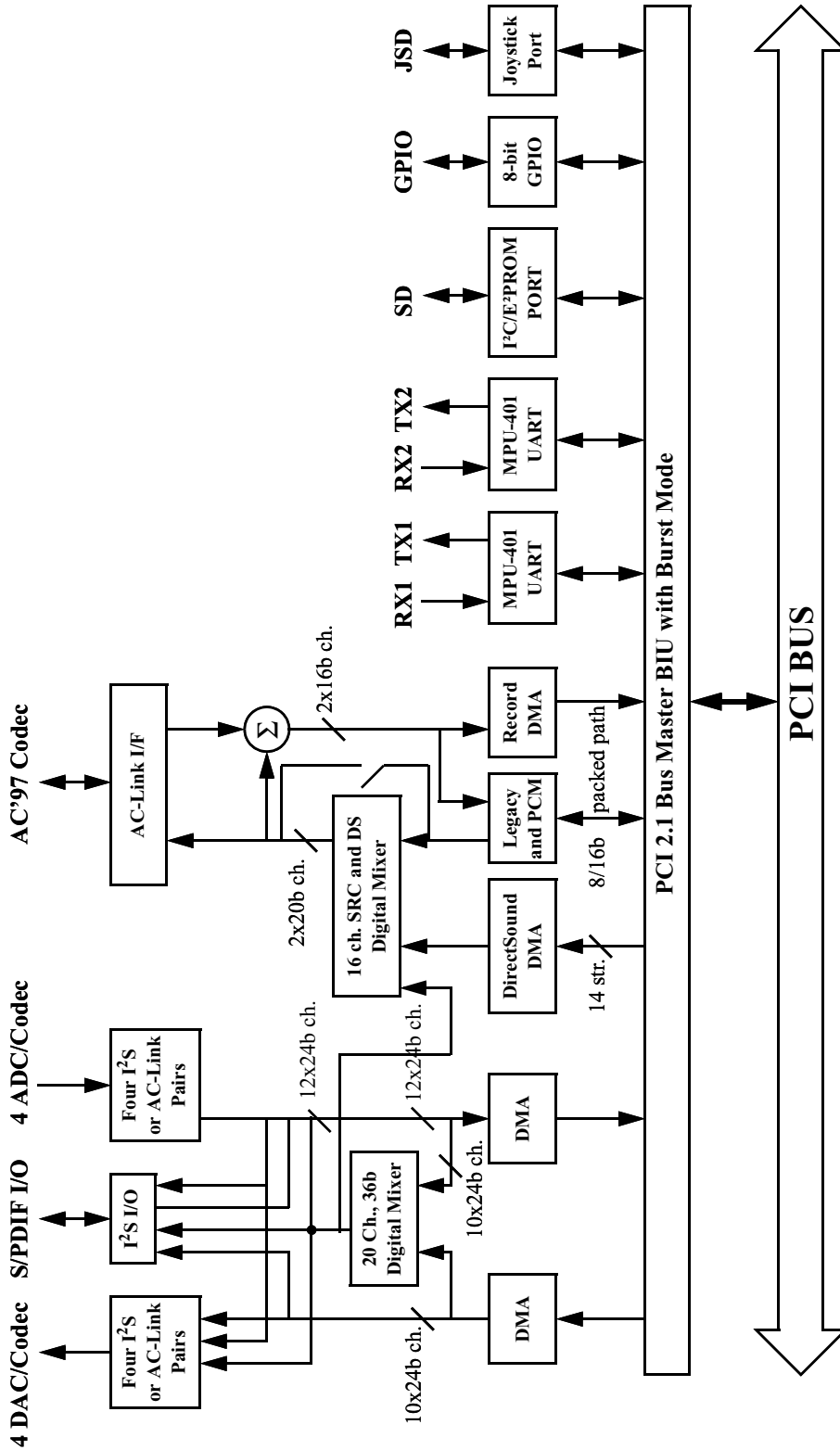

Figure 4-1. Functional Block Diagram

4.1 Controller Registers

The following registers are offset from base address set by PCI10. The 32 bytes I/O space includes main control / status registers, I²C interface, MPU-401 MIDI UARTs and game port control as well. Each CCSxx register is physically located at the address determined by [PCI10]+xx and accessed directly. The registers can be accessed as a byte, word or dword register.

Table 4-2. CCSxx Controller Register Map

Byte 3	Byte 2	Byte 1	Byte 0	Offset (Hex)
CClxx Index	Envy24 Status	Interrupt Mask	Envy24 Control/Stat.	00
NMI Index	NMI Data	NMI Status 1	CClxx Data	04
Consumer AC '97 Data Port		C. AC '97 Comm./Stat.	Cons. AC '97 Index	08
Game Port	NMI Status 2	MIDI 1 Comm./Status	MIDI UART 1 Data	0C
I ² C Port Control/Status	I ² C Port R/W Data	I ² C Port Byte Address	I ² C Port Dev. Address	10
Consumer Record DMA Current/Base Address				14
SERR# Shadow	-	Consumer Record DMA Count Address		18
Timer		MIDI 2 Comm./Status	MIDI UART 2 Data	1C

CCS00: Control / Status

Address Offset: 00h

Default Value: 00h

Bit	Attribute	Description
7	R/W	Entire Chip soft reset
6	R/W	Legacy mode only: 1: enable SERR# assertion for the DS DMA Channel-C interrupt 0: disable SERR# assertion for the DS DMA Channel-C interrupt (default)
5	RO	
4	R/W	Legacy mode only: 1: set the DOS WT volume control coming from DS Channel-C/D index registers B. 0: set the DOS FM volume control coming from SB mixer register space. (default) This bit is used in the legacy mode for the switching between FM and WT under DOS. For FM and WT under Windows, it is always coming from DS Channel-C/D index register B.
3	R/W	0: SERR# level (default) 1: SERR# edge (only one PCI clock width)
2	RO	-
1	R/W	Legacy mode only: 1: enable SERR# assertion for SB interrupt 0: disable SERR# assertion for SB interrupt (default)
0	R/W	Mode select: 0: SB mode 1: native mode

CCS01: Interrupt Mask

Address Offset: 01h

Default Value: FEh

Bit	Attribute	Description
7	R/W	Primary MIDI interrupt mask
6	R/W	Timer mask
5	R/W	Secondary MIDI interrupt mask.
4	R/W	Professional Multi-track playback and record. This is the macro interrupt mask for both playback and record.
3	R/W	FM/MIDI trapping interrupt mask
2	R/W	Playback DS DMA channels mask (effective for all the playback DMA channels from 0 to D)
1	R/W	Consumer record DMA channel interrupt mask
0	R/W	Consumer/SB mode playback interrupt mask (DMA channel E and F)

CCS02: Interrupt Status

Address Offset: 02h

Default Value: 00h.

These bits are sticky and only writing a 1 to that bit location will clear itself.

Bit	Attribute	Description
7	R/W/C	Primary MIDI receiver FIFO
6	R/W/C	Timer
5	R/W/C	Secondary MIDI receiver FIFO
4	RO	Multi-track playback or record. This is the macro interrupt status for both playback and record. To clear individual status bit, write a 1 to the associated bit location defined in section 4.4.
3	R/W/C	FM/MIDI trapping
2	RO	Direct Sound. This is the macro interrupt status for DS Channels (0 through D). To clear individual status bit, Write a 1 to the associated bit location defined in the DS DMA channel register section.
1	R/W/C	Native mode record (Record DMA)
0	R/W/C	Native/SB playback

CCS03: Envy24 Index

Address Offset: 03h

Default Value: 00h

Bit	Attribute	Description
7:6	R00b	-
5:0	R/W	Index register. Write the CCIxx register's xx index as described in section 4.1.1.

CCS04: Envy24 Data

Address Offset: 04h

Default Value: 00h.

Bit	Attribute	Description
7:0	See 4.1.1	Data register. Content for CCIxx register.

CCS05: NMI Status 1

Address Offset: 05h

Default Value: 00h

Description: This register pertains to legacy audio hardware synthesis emulation in DOS. Reading from this register will clear itself and de-assert the SERR# signal. However, it will not clear the SERR# bit PCI06[14]. To clear it, write 1 to that bit location instead. Refer to register CCS0E as well.

Bit	Attribute	Description
7	RO	1: PCI I/O read/write cycle if bit PCI43[5] is set to 1.
6	RO	1: SB 22C/24C write if bit PCI 43[6] is set to 1.
5	R0b	-
4	RO	1: SB interrupt (either SB DMA or SB F2 command) if bit [PCI10][1] is set to 1.
3	RO	1: DS channel C DMA interrupt (for FM/WT data transfer DMA) if bit [PCI10][6] is set to 1.
2	RO	1: MIDI 330h or [PCI_10]h+Ch write
1	R0	-
0	RO	1: FM data register write (389h/221h/229h/38bh/223h)

CCS06: NMI Data

Address Offset: 06h

Default Value: 00h

Description: This register pertains to legacy audio hardware synthesis emulation in DOS.

Bit	Attribute	Description
7:0	RO	Trapped data for TSR to be read (either FM 389h(221h,229h)/38bh(223h), MIDI 330h write, PIC I/O or SB 22C/24C write cycle (if enabled). Note that only write to FM data will assert SERR# but not write to FM index.

CCS07: NMI Index

Address Offset: 07h

Default Value: 00h

Description: This register pertains to legacy audio hardware synthesis emulation in DOS.

Bit	Attribute	Description
7:0	RO	Trapped data for FM Index only.

CCS08: Consumer AC'97 Index

Address Offset: 08h

Default Value: 00h

Bit	Attribute	Description
7	R0b	-
6:0	R/W	AC'97 registers Index. Refer to the AC'97 specification for register descriptions.

CCS09: Consumer AC'97 Command and Status

Address Offset: 09h

Default Value: 00h

Bit	Attribute	Description
7	R/W	Cold reset W: 1 to cold reset the codec. 0: CRST# will be de-asserted.
6	R/W	Warm reset W: 1 to warm reset the codec by asserting CSYNC. 0: CSYNC will be de-asserted.
5	R/W	W: 1 to write to AC'97 codec registers R: 1 indicate the write cycle is still in progress. Cleared when write cycle is complete.
4	R/W	W: 1 to read from AC'97 codec registers R: 1 indicate the read cycle is still in progress. This bit is cleared when there is valid data.
3	RO	AC'97 codec ready status bit. After power on, driver should check that this bit is 1 before accessing codec registers.
2	R0b	-
1	R/W	Enable VSR for Playback (DirectSound accelerator bypassed. Only Channel-E and F active)
0	R/W	Enable VSR for Record (digital return feature automatically disabled)

CCS0A: Consumer AC'97 Data Port

Address Offset: 0Ah - 0Bh

Default Value: 0000h

Bit	Attribute	Description
15:8	R/W	AC'97 codec register data higher byte (index 0Bh)
7:0	R/W	AC'97 codec register data lower byte (index 0Ah)

CCS0C: Primary MIDI UART Data

Address Offset: 0Ch

Default Value: 00h

Bit	Attribute	Description
7:0	R/W	MIDI UART data register

CCS0D: Primary MIDI UART Command / Status

Address Offset: 0Dh

Default Value: 00h

Bit	Attribute	Description
7:0	R/W	MIDI UART command and status register

CCS0E: NMI Status 2

Address Offset: 0Eh

Default Value: 00h

Description: This register pertains to legacy audio hardware synthesis emulation in DOS. Reading from this register will not clear itself. Refer to register CCS05 as well

Bit	Attribute	Description
7:6	RO	-
5:4	RO	FM bank indicator: 01: FM bank 0 (388h/220h/228h) 10: FM bank 1 (38ah/222h)
3:0	RO	PIC I/O cycle 0001: 20h write 0010: A0h write 0101: 21h write 0110: A1h write 1001: 20h read 1010: A0h read 1101: 21h read 1110: A1h read

CCS0F: Game Port

Address Offset: 0Fh

Default Value: 00h

Bit	Attribute	Description
7:0	RW	Game port register

CCS10: I²C Port Device Address

Address Offset: 10h

Default Value: 00h

Each write to this register will trigger to start the read/write cycle. So, before write to this I/O address, driver needs to check to make sure that the status bit is idle as defined in the I²C status register CCS13. The controller is always the only master and does not support multi-byte data burst mode.

Bit	Attribute	Description
7:1	R/W	I ² C device address. Device address "1010000" is reserved for the external I ² C E2PROM such as 24C02 for sub-vendor ID and configuration data.
0	R/W	0: read 1: write

CCS11: I²C Port Byte Address

Address Offset: 11h

Default Value: 00h

Bit	Attribute	Description
7:0	R/W	Byte address to read or write

CCS12: I²C Port Read / Write Data

Address Offset: 12h

Default Value: 00h

Bit	Attribute	Description
7:0	RW	Read or write data

CCS13: I²C Port Control and Status

Address Offset: 13h

Default Value: 00h

When bit 0 is 0 (meaning the I²C port is idle), SCLK (pin 71) will be tri-stated. Envy24 is providing the serial clock only when it reads/writes through I²C bus at a nominal rate of 31.25 KHz.

Bit	Attribute	Description
7	RO	Reflects the power strapping on GPIO3 (pin 53). A 1 (default) indicates external E ² PROM exists. A 0 (pull down by a resistor) means, no external E ² PROM connected.
6:2	0	-
1	R/W	Reserved. Keep at 0 state.
0	RO	I ² C port read/write status. 0: idle 1: busy

CCS14: Consumer Record DMA Current / Base Address

Index: 14h - 17h

Default Value: 00000000h:

Bit	Attribute	Description
31:28	R0	-
27:0	R/W	Write the Record DMA base address Read the current Record DMA count Byte aligned boundary is supported on this DMA channel.

CCS18: Consumer Record DMA Current / Base Count

Index: 18h - 19h

Default Value: 0000h

Bit	Attribute	Description
15:0	R/W	Write the Record DMA initial buffer size in bytes minus one. This register auto-decrements as the DMA transfer progresses. It reinitializes automatically to the original buffer size once it reaches 0 count. Read current Record DMA pointer.

See also registers CCI10 and CCI11 for Record DMA interrupt generation.

CCS1B: PCI Configuration SERR# Shadow

Address Offset: 1Bh

Default Value: 00h

Bit	Attribute	Description
7:1	R0	Reserved.
0	R/W	This bit shadows bit PCI04[8]. A 1 indicates SERR# assertion enabled, a 0 assertion disabled

CCS1C: Secondary MIDI UART Data

Address Offset: 1Ch

Default Value: 00h

Bit	Attribute	Description
7:0	R/W	MIDI UART data register

CCS1D: Secondary MIDI UART Command / Status

Address Offset: 1Dh

Default Value: 00h

Bit	Attribute	Description
7:0	R/W	MIDI UART command and status register

CCS1E: Timer

Index: 1Eh - 1Fh

Default Value: 4000h

Bit	Attribute	Description
15	R/W	0: Timer count disable (default) 1: Timer count enable
14:0	R/W	Read: the current timer value Write: to set up the period for the internal 15 bits timer to generate interrupt. This timer uses the internal MIDI logic clock (500 KHz).

4.2 Controller Indexed Registers

The following section describes the content to be written to or read through CCS03 and CCS04 registers and their effect on the controllers operation. These 8-bit indexed registers manage various functions. It may take multiple accesses if a functionality control takes more than one 8-bit register.

Registers CCI00 to CCI0F are defined for output through DMA Channel-E and Channel-F while CCI10 to CCI1F for the consumer section capture on Record DMA channel. See Table 4-2 in section 4.3 for the description of the DMA channels.

CCI00: Playback Terminal Count (High Byte)

Index: 00h

Default Value: 00h

Bit	Attribute	Description
7:0	WO	Write the high byte playback terminal count in bytes. This register auto-decrements as the DMA transfer progresses. When it reaches 0, it generates an interrupt. Program the desired count in dword units minus one to determine the interrupt frequency desired.

CCI01: Playback Terminal Count (Low Byte)

Index: 01h

Default Value: 00h

Bit	Attribute	Description
7:0	WO	Write the high byte playback terminal count in bytes. See description above in CCI00.

CCI02: Playback Control

Index: 02h

Default Value: 00h

Bit	Attribute	Description
7	R/W	Turbo mode (4x up sampling in the host by software), valid only when sampling rate is at 12 KHz or above. When this bit is set to 1, the Channel E and F in DirectSound will accept the 4x up streams.
6	R/W	Reserved
5	R0b	-
4	R/W	0: 16 bits signed 1: 8 bits unsigned
3	R/W	0: mono 1: stereo
2	R/W	FIFO flush (sticky bit. Requires toggling).
1	R/W	Pause
0	R/W	Playback enable

CCI03: Playback Left Volume / Pan

Index: 03h

Default Value: 07h

Bit	Attribute	Description
7:6	R00b	-
5:0	R/W	Left stream volume: 1.5dB attenuation per step. Default: -10.5dB 000000: 0dB 000111 : 10.5 dB (default) 011111: -46.5dB 111111: muted (instead of -94.5dB)

CCI04: Playback Right Volume / Pan

Index: 04h

Default Value: 07h

Bit	Attribute	Description
7:6	R00b	-
5:0	R/W	Right stream volume: 1.5dB attenuation per step. Default: -10.5dB 000000: 0dB 000111 -10.5 dB (default) 011111: -46.5dB 111111: muted (instead of -94.5dB)

CCI05: Soft Volume / Mute Control

Index: 05h

Default Value: 05h (about 6.4ms from 0 to 96dB)

Bit	Attribute	Description
7:0	R/W	Soft volume update rate (48 KHz/[CCI05], about every 20 μ s*[CCI05] per 1.5dB step). These bits apply to all the DirectSound channels 0 through D as well.

CCI06: Playback Sampling Rate (Low Byte)

Index: 06h

Default Value: 0xFFh

Bit	Attribute	Description
7:0	R/W	see note below.

Note: SR, consumer mode (WAV PCM on Channel E and F) Sampling Rate is a 20-bit value programmed among registers CCI06 through CCI08. $SR = fs * 2^{20}/48000$. This has the resolution of less than 1Hz. When it is programmed to $(2^{20} - 1)$, sampling rate will be rounded to 48 KHz exactly.

CCI07: Playback Sampling Rate (Middle Byte)

Index: 07h

Default Value: 0xFFh

Bit	Attribute	Description
7:0	R/W	see note under CCI06.

CCI08: Playback Sampling Rate (High Byte)

Index: 08h

Default Value: 0x0Fh

Bit	Attribute	Description
7:4	R0h	-
3:0	R/W	see note under CCI06.

CCI10: Record Current / Base Terminal Count (High Byte)

Index: 10h

Default Value: 00h

Bit	Attribute	Description
7:0	WO	Write the high byte record terminal count in bytes. Like register CCS18, this register also auto-decrements as the DMA transfer progresses. When it reaches 0, it generates and interrupt. Program the desired count in dword units minus one to determine the interrupt frequency desired.

CCI11: Record Current / Base Terminal Count (Low Byte)

Index: 11h

Default Value: 00h

Bit	Attribute	Description
7:0	WO	Write the low byte record terminal count in bytes. See description above in CCI10.

CCI12: Record Control

Index: 12h

Default Value: 00h

Bit	Attribute	Description
7	R/W	1: Digital return enable: (only for DMA Channel-10) The recorded signal will be the sum of CSDIN and SRC outputs.
6:3	R0h	-
2	R/W	0: 16-bit signed; 1: 8-bit unsigned
1	R/W	0: stereo; 1: mono
0	R/W	0: Record disable 1: Record enable

Conditions in native mode record DMA transfer: It is assumed that:

- 16 bit mono: starting address is in 2X and byte count is 2X (i.e., multiples of 2) bytes -1
- 16 bit stereo: starting address is in 4X and byte count is 4X bytes -1
- 8 bit mono: starting address is in 1X and byte count is 1X bytes -1
- 8 bit stereo: starting address is in 2X and byte count is 2X bytes -1

Each time DMA stops, the lowest bytes of address and count/TC are all need to be programmed before it starts again. Consumer record only at 48 KHz when using AC'97 codecs, such as the VT1611 that do not incorporate VSR support. Use the VT1611A to support hardware native VSR.

CCI20: GPIO Data

Index: 20h

Default Value: 00h

The direction is set up in CCI22 the GPIO direction control register. These register bits can be writable only when the corresponding mask bit is zero in the mask register. Also, if the direction is output, it reads back the last data written. Some GPIO pins may be optionally configured for predefined functions. The use of these will depend upon board configuration as defined by the E²PROM settings content. See PCI60 (32-bit) register description for more details.

Bit	Attribute	Description
7:0	R/W	GPIO data (Warning: GPIO pins may be shared with other functions)

CCI21: GPIO Write Mask

Index: 21h

Default Value: FFh

Bit	Attribute	Description
7:0	R/W	GPIO write mask 0: Corresponding CCI20 register bit can be written. 1: Can NOT be written.

CCI22: GPIO Direction Control

Index: 22h

Default Value: 00h

Bit	Attribute	Description
7	R/W	GPIO7 direction. If 2nd MIDI UART in use, this bit will be read as 0 always.
6	R/W	GPIO6 direction. If 2nd MIDI UART in use, this bit will be read as 1 always
5	R/W	GPIO5 direction. If external clock synthesizer is used, this bit will be read as 1 always.
4	R/W	GPIO4 direction. If external clock synthesizer is used, this bit will be read as 1 always.
3	R/W	GPIO3 direction. During reset, this pin is used for E ² PROM power-on strapping.
2	R/W	GPIO2 direction. If TESTEN# pin is active, this pin is always input.
1:0	R/W	GPIO1 and GPIO0 direction control register.

For all bits 0: input; 1: output.

CCI30: Consumer Section Power Down

Index: 30h

Default Value: 00h

Bit	Attribute	Description
7	R/W	1: Crystal clock generation power down for XTAL_1
6	R/W	1: Game port analog power down
5	R/W	Reserved.
4	R/W	1: Stop I ² C port clock
3	R/W	1: Stop MIDI clock
2	R/W	1: Stop AC'97 clock
1	R/W	1: Stop DS Block clock
0	R/W	1: Stop PCI clock for SB, DMA controller (excluding PCI BIU, config. space and this register)

CCI31: Multi-Track Section Power Down

Index: 31h

Default Value: 00h

Bit	Attribute	Description
7	R/W	1: Crystal clock generation power down for XTAL_2
6:3	R/W	Reserved
2	R/W	1: Stop S/PDIF clock
1	R/W	1: Stop Professional digital mixer clock
0	R/W	1: Stop Multi-track I ² S serial interface clock

There are four power states defined in the PCI bus power management spec.

States	Description
D0	Normal operation state after system power up or internal reset
D1	not supported.
D2	Power down all the blocks defined in the power down registers.
D3(hot)	Same as D2 state, except a transition to D0 will generate an internal reset (incl. PCI config. space)

4.3 DDMA Registers

The following register definitions are derived from the DDMA spec. They are used by the SoundBlaster legacy block (playback or record) Microsoft Windows MMSystem Wave (WAV) playback, also known as native mode. The following registers are offset from the base address set by PCI14 and described below by the [PCI14] symbol to reflect the DDMA base address.

I/O Address	Attribute	Description
[PCI14] + 0h	R/W	DMA Base and Current Address bit 0-7
[PCI14] + 1h	R/W	DMA Base and Current Address 8 : 15
[PCI14] + 2h	R/W	DMA Base and Current Address 16 :23
[PCI14] + 3h	R/W	DMA Base and Current Address 24 : 31
[PCI14] + 4h	R/W	DMA Base and Current Count 0 : 7
[PCI14] + 5h	R/W	DMA Base and Current Count 8 :15
[PCI14] + 6h	-	DMA Base and Current Count 16 : 23 (Not supported, reflecting the 64K page boundary)
[PCI14] + 7h	-	Reserved
[PCI14] + 8h	R/W	Status and Command
[PCI14] + 9h	-	Request. Not implemented.
[PCI14] + Ah	-	Reserved
[PCI14] + Bh	W	Mode
[PCI14] + Ch	W	Master reset
[PCI14] + Dh	-	Master clear. Not implemented.
[PCI14] + Eh	-	Reserved
[PCI14] + Fh	W	Channel Mask

4.4 DMA Path Descriptions

Physically, there are 19 individual bus master DMAs, 17 for playback and 2 for record. DMA Channels 0 to F are for the Consumer section (both native/SoundBlaster and DirectSound streams playback) as described in 4.4. Record DMA is used for native 48 KHz record. Both of consumer playback and record paths are interfaced to an external AC'97 compliant codec via AC-link. Channel-10 is used for transferring 10 individual data streams (e.g., 8 multi-track playback and one stereo S/PDIF) to 24-bit outputs. The relevant register descriptions can be found in section 4.5. These 10 streams are sent from the system memory in interleaved data format through one DMA FIFO/address/count/control register set only. Channel-11 is used for transferring 12 individual data streams (e.g. one stereo pair returned from the professional digital mixer, 8 professional multi-track record and one stereo S/PDIF input). These 12 streams are sent to the system memory in interleaved data format through one DMA FIFO/address/count/control register set only. Both of these playback/record channels can support externally I²S type and AC'97 compliant codecs.

Table 4-3. DMA Channels and Respective Functionality

DMA Channels	Consumer/Multi-Track	Direction	Destination/Source
Channel-0	DirectSound - 0	O	CSDOUT: L/R
Channel-1	DirectSound - 1	O	CSDOUT: L/R
Channel-2	DirectSound - 2	O	CSDOUT: L/R
Channel-3	DirectSound - 3	O	CSDOUT: L/R
Channel-4	DirectSound - 4	O	CSDOUT: L/R
Channel-5	DirectSound - 5	O	CSDOUT: L/R
Channel-6	DirectSound - 6	O	CSDOUT: L/R
Channel-7	DirectSound - 7	O	CSDOUT: L/R
Channel-8	DirectSound - 8	O	CSDOUT: L/R
Channel-9	DirectSound - 9	O	CSDOUT: L/R
Channel-A	DirectSound - A	O	CSDOUT: L/R
Channel-B	DirectSound - B	O	CSDOUT: L/R
Channel-C	DirectSound - C (FM/WT-L)	O	CSDOUT: L
Channel-D	DirectSound - D (FM/WT-R)	O	CSDOUT: R
Channel-E	DirectSound - E (PCM-L)	O	CSDOUT: L
Channel-F	DirectSound - F (PCM-R)	O	CSDOUT: R
Record DMA	SB/MMSYS PCM L/R Record	I	CSDIN: L/R
Channel-10	Multi-track Playback (10 interleaved)	O	PSDOUT0-3 L/R and SPDOUT
Channel-11	Multi-track Record (12 interleaved)	I	PSDIN0-3 L/R, SPDIN and digital mix

4.5 Consumer Section DMA Channel Registers

The following registers are offset from base address set by PCI18. The DSx registers are located at [PCI18]+x. The 16 bytes I/O space controls the consumer section DMA channels for DOS legacy, native and DirectSound.

Table 4-4. DSx Consumer DMA Channel Register Map

Byte 3	Byte 2	Byte 1	Byte 0	Offset (Hex)
DirectSound DMA Interrupt Status		DirectSound DMA Interrupt Mask		00
Channel Data				04
-			Channel Index	08
-				0C

DS0: DirectSound DMA Interrupt Mask

Address Offset: 00 - 01h

Default Value: 3FFFh

Bit	Attribute	Description
15:14	R00b	-
13:00	R/W	Each bit corresponding to the interrupt mask for each channel (0 to D). Default is masked.

DS2: DirectSound DMA Interrupt Status

Address Offset: 02 - 03h

Default Value: 0000h

Bit	Attribute	Description
15:14	R00b	-
13:0	R/WC/	Each bit corresponding to the interrupt status of each channel (0 to D) These are sticky bits. The driver needs to clear by writing a 1 to the corresponding bit.

DS4: Channel Data

Address Offset: 04h - 07h

Default Value: 00000000h.

Bit	Attribute	Description
31:0	R/W	Channel Data register. See 32-bit index register description after Table 4-5 .

DS8: Channel Index

Address Offset: 08h

Default Value: 00h

Bit	Attribute	Description
7:4	R/W	Channel number. Valid only from Channel-0 to D. E and F are reserved for PCM streams regardless whether running in native or SB mode.
3:0	R/W	Channel Index register. The table below is used for command decoding purposes.

Table 4-5. DS8 Register, Low Nibble Index Description Applicable to Channel-0 through D

Index	Attribute	Description
0h	R/W	Bits [27:0] W: Buffer_0 DMA base address[27:0] R: current active DMA buffer address[27:0]. Byte address.
1h	R/W	Bits [15:0] W: Buffer_0 DMA base count [15:0] R: current active DMA count [15:0]. Program byte count minus one.
2h	R/W	Bits[27:0] W: Buffer_1 DMA base address bit [27:0] R: same as in index 0h. Byte address
3h	R/W	Bits [15:0] W: Buffer_1 DMA base count [15:0] R: same as in index 1h. Program byte count minus one.
4h	R/W	Bits [7:0] R/W: Channel Control and Status register.
5h	R/W	Bits [19:0] Channel Sampling Rate
6h	R/W	Bits [13:0] (see note below) Channel left and right volume/pan control

Note:

- When the playback enable bit is changed from 0 to 1 (in Index 4 bit 0), the first active buffer will be from buffer 0. Before this, the return active address and count will not be updated.

Conditions in DMA transfer:

- 16 bit mono: starting address is in 2X and count is multiple of 2X bytes (-1)
- 16 bit stereo: starting address is in 4X and count is multiple of 4X bytes (-1)
- 8 bit mono: starting address is in 1X and count is multiple of 1X bytes (-1)
- 8 bit stereo: starting address is in 2X and count is multiple of 2X bytes (-1)

Channel Control and Status at Index 4h (DS8 = x4h)

Default: 00000060h

Bit	Attribute	Description
31:8	R000h	-
7	RO	1: indicating that the current active buffer is Buffer_1. 0: indicating that the current active buffer is Buffer_0. To avoid the case of reading this bit during the transition, it is recommended that driver read this bit in the ISR so that the returned address and count are in-sync. with the buffer status.
6	R/W	0: Buffer_1 auto init. disable (single block mode) 1: Buffer_1 auto init. enable (loop mode), default.
5	R/W	0: Buffer_0 auto init. disable (single block mode) 1: Buffer_0 auto init. enable (loop mode), default.
4	R/W	Flush FIFO
3	R/W	1: stereo; 0: mono (default). For the DirectSound path this bit is only valid and can be programmed in the even number of channels, i.e., 0,2,4,..,C. The second data element will be routed to the next odd slot into the internal SRC core. Driver should not program the odd number channel address and count etc. since it is occupied. (sampling rate and volume should still be programmed, however).
2	RW	Consumer mode data format: 0: 16-bit signed; 1: 8-bit unsigned
1	RW	DMA request 1:pause
0	RW	DMA request 1: start, 0:stop

Consumer Mode Sampling Rate at Index 5h (DS8 = x5h)

Index: 05h

Default Value: 0x000FFFFFh (48 KHz)

Bit	Attribute	Description
31:20	R0	-
19:00	R/W	SR: Sampling Rate for all DirectSound streams (except Channel E and F, see CCI06) is a 20-bit value. $SR = fs * 2^{20}/48000$. This has the resolution of less than 1Hz. When it is programmed to $(2^{20} - 1)$, sampling rate will be rounded to 48 KHz exactly.

Consumer Mode Left / Right Volume at Index 06h (DS8 = x6h)

Index: 06h

Default: 00000707h

Bit	Attribute	Description
31:14	R0	-
13:8	R/W	Right volume: 1.5dB attenuation per step. 000000: 0dB 000111: -10.5 dB (default) 011111: -46.5dB 111111: muted (instead of -94.5dB)
7:6	R0	-
5:0	R/W	Left volume : 1.5dB attenuation per step. Default: -10.5dB. Same table as in Right volume.

Note:

Channels E and F are dedicated for consumer PCM left and right streams respectively for either Microsoft Windows MMSYSTEM Wave (WAV) or SoundBlaster. In the MMSYSTEM mode, the sampling rate and the volume are defined in the CCS3 and CCS4 index registers. In the SB mode, the sampling rate is coming from SB command and volume is defined in the SB mixer registers.

Channel C and D are dedicated for FM synthesis output left and right streams respectively in the SB mode. In this case, the FM volume will be coming from the SB mixer register space setting. The sampling rate, however, is determined from the above DS8 index registers.

Table 4-6. Channel Parameter Controls

Channels	Mode	Data	Interrupt Status Bit	Volume Control	Sampling Frequency
E:F	Legacy	DOS SB PCM	INTA# (routing)	SB mixer register	SB command
C:D	Legacy	DOS FM	NMI: for I/O trapping INTA# or NMI for data transfer	SB mixer register	DS8, index register 5 Programmed by TSR
C:D	Legacy	DOS WT	Same as above	DS8=x6h CCS00[4]=1b	Same as above.
E:F	Native	Native PCM	INTA#: CCS02	CCS03, CCS04	SE index registers 6-8
C:D	Native	Native FM/WT	INTA#: DS2, DS3	DS8, index register 6	DS8, index register 5

4.6 Professional Multi-Track Control Registers

The following registers are offset from base address set by PCI1C. The MTxx registers are located at [PCI1C]+xx. The 64 bytes I/O space controls the professional multi-track record and playback, audio stream routing, digital mixer and related output capability. Refer to **Table 4-3** on page 19 of this chapter for a concise description of the DMA channels involved.

Table 4-7. MTxx Controller Register Map

Byte 3	Byte 2	Byte 1	Byte 0	Offset (Hex)
-	FS data format	Sampling Rate Select.	DMA Int. Mask/Status	00
Professional section AC '97 Data Port		P. AC '97 Comm./Stat.	Prof. AC '97 Index	04
-				08
-				0C
Professional Playback DMA Current/Base Address				10
P. Playback DMA Current/Base Terminal Count		Prof. Playback DMA Current/Base Count		14
-			P. Playback Control	18
-				1C
Professional Record DMA Current/Base Address				20
P. Record DMA Current/Base Terminal Count		Prof. Record DMA Current/Base Count		24
-			P. Record Control	28
-				2C
Routing control to SPDOUT		Routing control to PSDOUT[3:0]		30
Captured data Routing Selection				34
Volume Control Rate	Vol. Control Ch. Index	L/R Volume Control		38
Peak meter data	Peak meter index	-	Mixer monitor return	3C

4.6.1 Multi-Track Mode Control Registers

MT00: Professional Section DMA Interrupt Mask and Status

Address Offset: 00h

Default Value: C0h

This register relates to both Channel-10 and 11 (Professional playback and record). When DMAs are stopped, the last latched value is retained. This “DC” value may affect the digital mixer operation.

Bit	Attribute	Description
7	R/W	Multi-track record interrupt mask
6	R/W	Multi-track playback interrupt mask
5:2	R0	-
1	R/W/C	Multi-track record interrupt status. Write a 1 to clear.
0	R/W/C	Multi-track playback interrupt status. Write a 1 to clear.

MT01: Professional Section Sampling Rate Select

Address Offset: 01h

Default Value: 00h.

This register applies to both Channel-10 and 11. For S/PDIF input, correct sampling rate must be set as well. See **Figure 4-4-3** and **Figure 4-4-4** on page 27 and page 28 respectively, in this chapter.

Bit	Attribute	Description
7:5	R000b	-
4	R/W	S/PDIF input clock as the master. 0: disabled 1: enabled. S/PDIF receiver chip provides the master clock through SPMCLKIN (pin 111) Note that in this mode, 256X is the highest master clock available while the AC'97 MCLK requires 512X. VIA Technologies' AC'97 codecs, such as the VT1611, are designs based on BCLK which uses MCLK/2, i.e. 256X. When S/PDIF provides the master clock, if VIA Technologies' AC'97 codecs are used, before setting S/PDIF as the master clock, proceed to switching the primary codec into slave mode (refer to the VT1611 datasheet). In this mode PBCLK will be output from Envy24.
3:0	R/W	Codec sampling rate select: All multi-track channels are set to the same rate. These bits are ignored if S/PDIF input is master. 0000: 48 KHz 0001: 24 KHz 0010: 12 KHz 0011: 9.6 KHz 0100: 32 KHz 0101: 16 KHz 0110: 8 KHz 0111: 96 KHz 1111: 64 KHz 1000: 44.1 KHz 1001: 22.05 KHz 1010: 11.025 KHz 1011: 88.2 KHz others: reserved

MT02: Professional Section AC'97 Codec I²S Data Format

Address Offset: 02h

Default Value: 00h

Bit	Attribute	Description
7:4	R0	-
3	R/W	MCLK/LRCLK ratio, 0: 256x (default) 1: 128x
2	R/W	SCLK/LRCLK ratio, i.e. bpf (bits per frame, each frame corresponding to 1/SR) Typically useful for 44.1 KHz sampling rate and its multiples where converters use 384X oversampling. If S/PDIF is used as reflected in PCI63[0] or 1, 64bpf mode is forced and this bit is rendered inactive. 0: 64bpf (32/32) default. (PMCLK on pin 85 is 256 * LRCLK) 1: 48bpf (24/24) (PMCLK is 384 * LRCLK)
1:0	R/W	Data format: 00: I ² S (timing diagram provided below) others: Reserved

See **Figure 4-4-2** below for a timing diagram for bits [1:0]. See **Figure 4-4-3** and **Figure 4-4-4** on page 27 and page 28 respectively for the visual description of other bits.

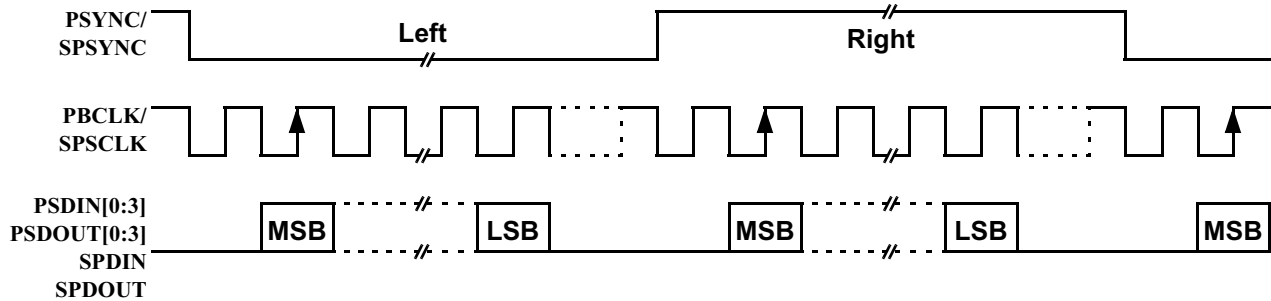

Figure 4-2. I²S Format Timing Diagram

MT04: Professional Section AC'97 Codec Index

Address Offset: 04h

Default Value: 00h

Bit	Attribute	Description
7	R0	-
6:0	R/W	AC'97 registers Index. Refer to the AC'97 specification for register descriptions.

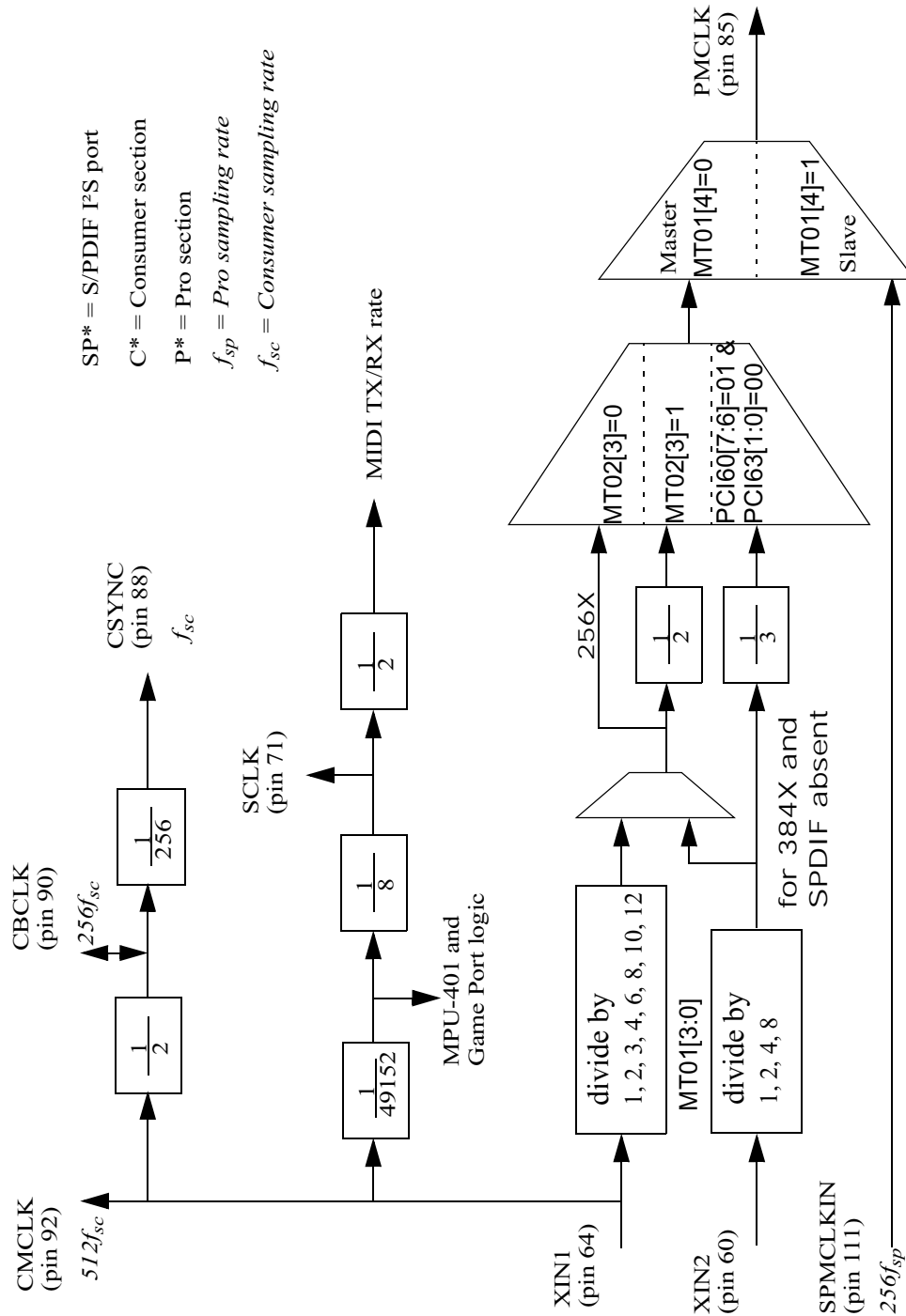

Figure 4-3. Crystals to Master Clocks Clock Generation Tree

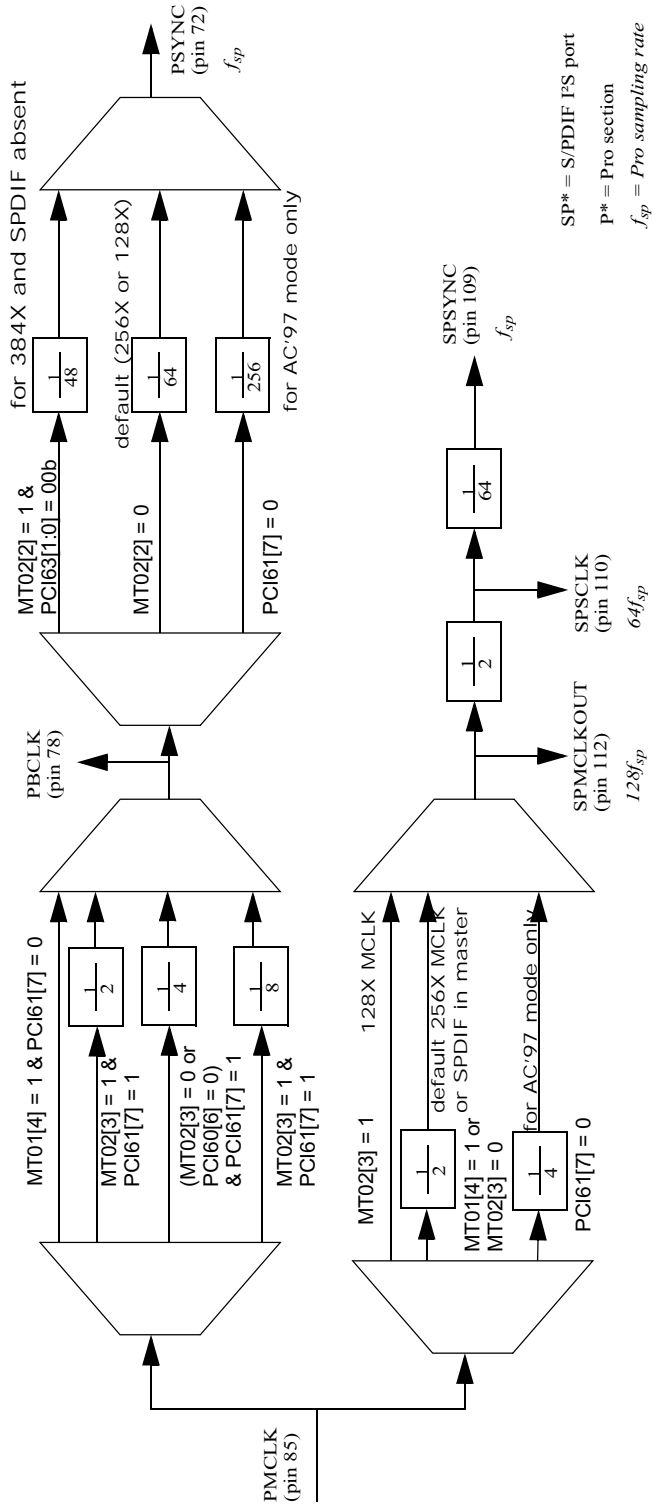

Figure 4-4. Master Clocks to Bit Clocks, L/R Clocks and Sync Generation

MT05: Professional Section AC'97 Codec Command / Status

Address Offset: 05h

Default Value: 00h

Bit	Attribute	Description
7	R/W	Cold reset. Write 1 to assert PRST# (pin105) active. Write back 0 to remove reset condition from all professional section codecs.
6	R/W	Warm reset. Write 1 to have warm reset by asserting PSYNC (pin 72). This bit together with PRST# (pin 105) active (MT05[7]=1) can be used to set the external VIA Technologies' primary AC'97 codec to slave mode (such as the VT1611). This must be done when S/PDIF input is the master. Apply Cold reset to restore codec master mode.
5	R/W	Write 1 to write to AC'97 codec register Reading a 1 indicates the write cycle is still in progress, cleared when write cycle complete.
4	R/W	Write 1 to read AC'97 CODEC register Reading a 1 indicates the read cycle is still in progress, cleared when there is valid data.
3	RO	AC'97 codec ready status bit. After power-on, check that this bit is 1 before accessing codec registers.
2	R0b	-
1:0	R/W	ID for external AC'97 registers read/write. 00: select primary AC'97 codec. 01: select second slave AC'97 codec. 10: select third slave AC'97 codec. 11: select fourth slave AC'97 codec.

MT06: Professional Section AC'97 Codec Data Port

Address Offset: 06h - 07h

Default Value: 00h

Bit	Attribute	Description
15:8	R/W	AC'97 codec register data high byte (index 07h) Refer to the AC'97 specification for register descriptions..
7:0	R/W	AC'97 codec register data low byte (index 06h). Refer to the AC'97 specification for register descriptions.

4.6.2 Multi-Track Playback Registers

The following figure is a visual representation of the multi-track data transfer mechanism. A ping-pong buffer structure is implemented for a seamless flow of multiple streams. 32-bit data transfers are used regardless of the audio data resolution. All transfer data are left (MSB) justified. Each transfer request results into a PCI bus master burst cycle.

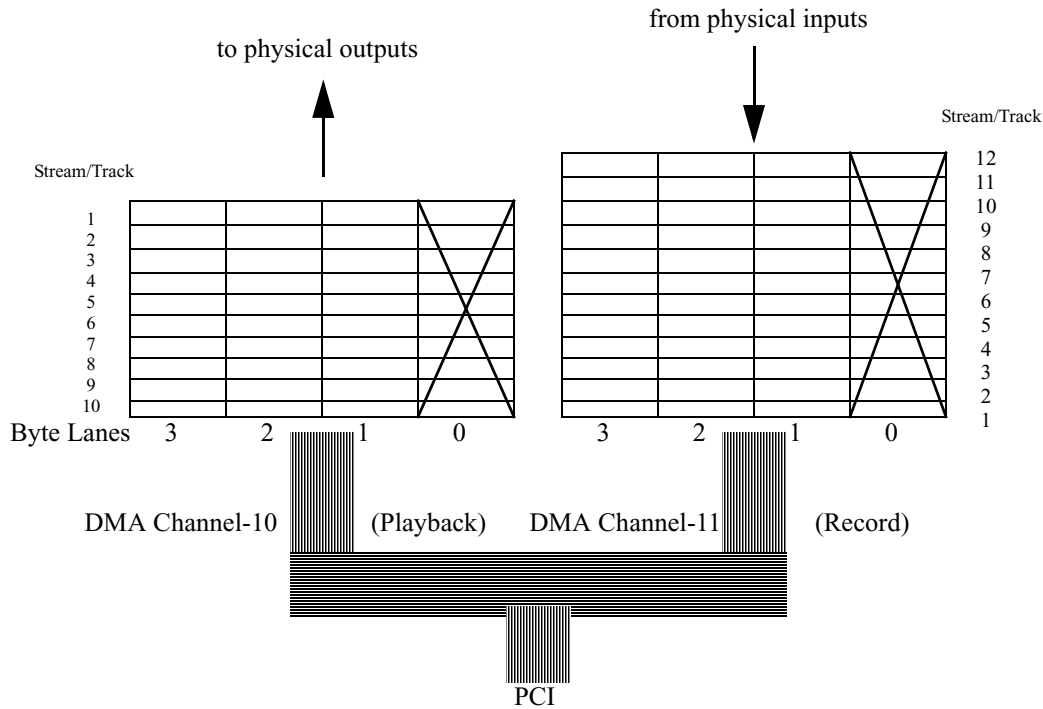

Figure 4-5. Multi-Track DMA Transfer

MT10: Professional Section Playback DMA Current / Base Address

Index: 10h - 13h

Default Value: 00000000h. Channel-10 interleaves 10 slots, each with 32-bit from the system memory.

Bit	Attribute	Description
31:28	R0h	- (Address space beyond 256MB is not supported)
27:2	R/W	Write the Playback DMA base address in dword units (up to 256 MB address space supported) Read current address in dword units.
1:0	R00b	- (This DMA channel supports dword boundary only)

MT14: Professional Section Playback DMA Current / Base Count

Index: 14h - 15h

Default Value: 0000h

Bit	Attribute	Description
15:0	R/W	Write the Playback DMA initial buffer size in dword units minus one. This register auto-decrements as the DMA transfer progresses. It reinitializes automatically to the original buffer size once it reaches 0 count. Read the current Playback DMA pointer.

MT16: Professional Section Playback Current / Base Terminal Count

Index: 16 - 17h

Default Value: 0000h

Bit	Attribute	Description
15:0	WO	Write the terminal count. This register also auto-decrements as the DMA transfer progresses. When it reaches 0, it generates and interrupt. Program the desired count in dword units minus one to determine the interrupt frequency desired.

MT18: Professional Section Playback and Record Control

Index: 18h

Default Value: 00h.

Bit	Attribute	Description
7:3	R0	-
2	R/W	1: Record start; 0: Record stop. Shadowed in MT28[0].
1	R/W	1: Pause; 0: Resume
0	R/W	1: Playback start; 0: Playback stop

4.6.3 Multi-Track Record Registers

MT20: Professional Section Record DMA Current / Base Address

Index: 20h - 23h

Default Value: 00000000h. Channel-11 interleaves 12 slots, each with 32-bit data to the system memory.

Bit	Attribute	Description
31:28	R0h	- (Address space beyond 256MB is not supported)
27:2	R/W	Write the Playback DMA base address in dword units (up to 256 MB address space supported) Read current address in dword units.
1:0	R00b	- (This DMA channel supports dword boundary only)

MT24: Professional Section Record DMA Current / Base Count

Index: 24 - 25h

Default Value: 0000h

Bit	Attribute	Description
15:0	R/W	Write the Record DMA initial buffer size in dword units minus one. This register auto-decrements as the DMA transfer progresses. It reinitializes automatically to the original buffer size once it reaches 0 count. Read the current Record DMA pointer after having allowed at least 2 sample frames.

MT26: Professional Section Record Current / Base Terminal Count

Index: 26h - 27h

Default Value: 0000h

Bit	Attribute	Description
15:0	WO	Write the terminal count. This register also auto-decrements as the DMA transfer progresses. When it reaches 0, it generates and interrupt. Program the desired count in dword units minus one to determine the interrupt frequency desired.

MT28: Professional Section Record Control

Index: 28h

Default Value: 00h

Bit	Attribute	Description
7:1	R0	-
0	R/W	1: Record start; 0: Record stop. Same functionality as MT18[2]

4.6.4 Professional Section Digital Loopback

The Envy24 provides an extensive routing capability of the data streams. The following registers control the routing from numerous sources to various destination. Insertion of the stream routing functionality adds a maximum of a single sample cycle delay with respect to the original data. The switch matrix being so complex, careful register setting is crucial to avoid undesirable effects. For simplicity of the register description only pin names are used. Refer to the pin list for pin numbers and location.

The diagram below is a visual representation of possible connection. If a dot is missing on an intersection, it reflects the lack of routing capability.

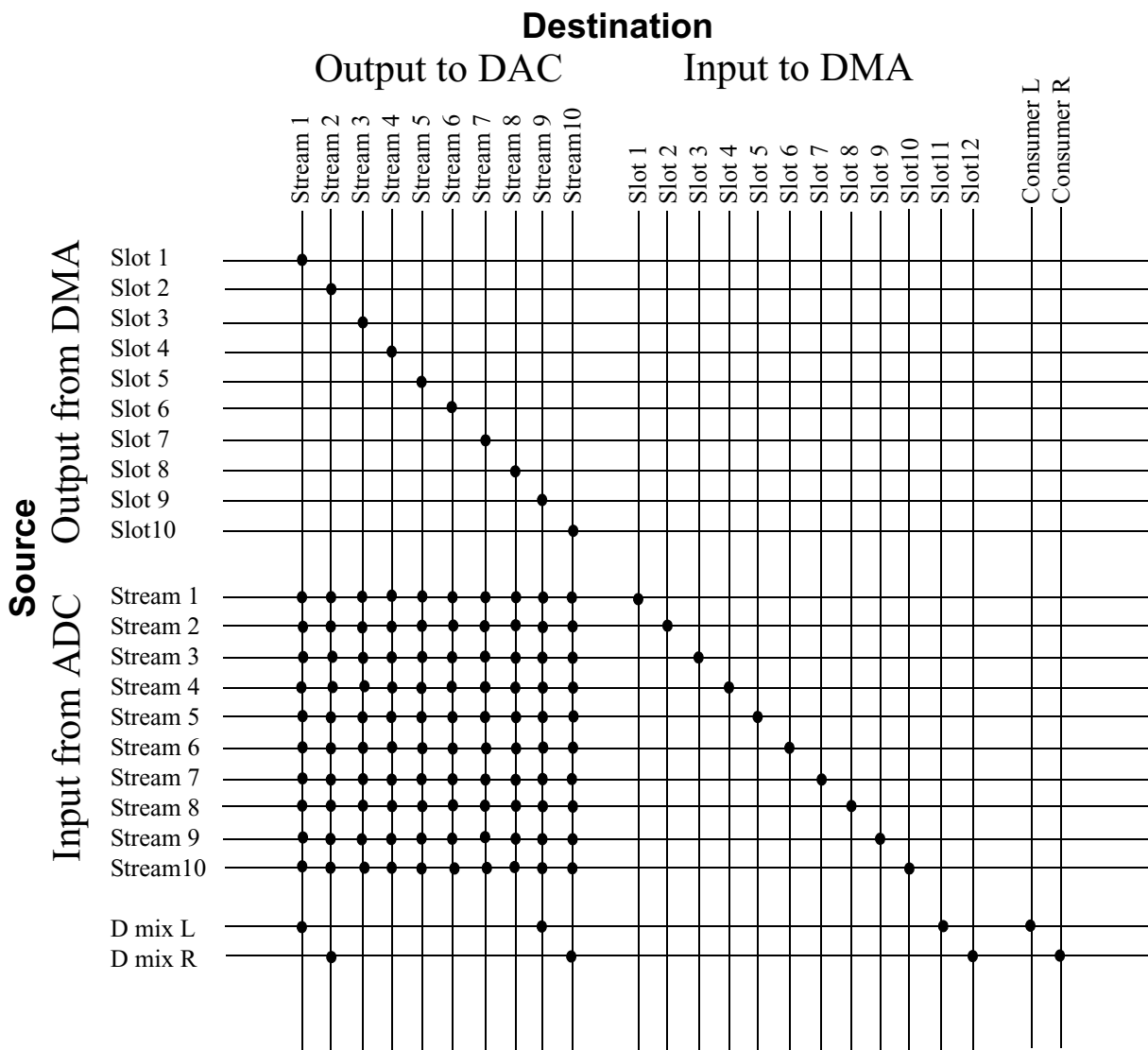

Figure 4-6. Data Stream Routing Capabilities

MT30: Routing Control for Data to PSDOUT[0:3]

Address Offset: 30h - 31h

Default Value: 00h

When PSDIN[0:3] or SPDIN are selected as the source, refer to register MT34.

Bit	Attribute	Description
15:14	R/W	PSDOUT[3] Right source 00: from DMA Channel-10 output slot 8 01: - 10: from PSDIN[X] loopback 11: from SPDIN input loopback
13:12	R/W	PSDOUT[2] Right source 00: from DMA Channel-10 output slot 6 01: - 10: from PSDIN[X] loopback 11: from SPDIN input loopback
11:10	R/W	PSDOUT[1] Right source 00: from DMA Channel-10 output slot 4 01: - 10: from PSDIN[X] loopback 11: from SPDIN input loopback
9:8	R/W	PSDOUT[0] Right source 00: from DMA Channel-10 output slot 2. 01: from digital mixer monitor Right output 10: from PSDIN[X] loopback 11: from SPDIN input loopback
7:6	R/W	PSDOUT[3] Left source 00: from DMA Channel-10 output slot 7 01: - 10: from PSDIN[X] loopback 11: from SPDIN input loopback
5:4	R/W	PSDOUT[2] Left source 00: from DMA Channel-10 output slot 5 01: - 10: from PSDIN[X] loopback 11: from SPDIN input loopback
3:2	R/W	PSDOUT[1] Left source 00: from DMA Channel-10 output slot 3 01: - 10: from PSDIN[X] loopback 11: from SPDIN input loopback
1:0	R/W	PSDOUT[0] Left source 00: from DMA Channel-10 output slot 1 01: from digital mixer monitor Left output 10: from PSDIN[X] loopback 11: from SPDIN input loopback

MT32: Routing Control for SPDOUT

Address Offset: 32h - 33h

Default Value: 0000h

When PSDIN[0:3] or SPDIN are selected as the source, refer to register 38h-3Bh.

Bit	Attribute	Description
15	R/W	SPDIN input loop back to SPDOUT Right output 1: SPDIN Right input 0: SPDIN Left input
14 : 12	R/W	PSDIN[X] input loop back to SPDOUT Right output 000: PSDIN[0]: L 001: PSDIN[0]: R 010: PSDIN[1]: L 011: PSDIN[1]: R 100: PSDIN[2]: L 101: PSDIN[2]: R 110: PSDIN[3]: L 111: PSDIN[3]: R
11	RW	SPDIN input loop back to SPDOUT Left output 1: S/PDIF right input 0: S/PDIF left input
10:8	RW	PSDIN[X] input loop back to SPDIOOUT Left output 000: PSDIN[0]: L 001: PSDIN[0]: R 010: PSDIN[1]: L 011: PSDIN[1]: R 100: PSDIN[2]: L 101: PSDIN[2]: R 110: PSDIN[3]: L 111: PSDIN[3]: R
7:4	R0h	-
3:2	R/W	Source loop back to the SPDOUT Right output 00: from DMA Channel-10 slot 10 01: from digital mixer monitor Right output 10: from PSDIN[X] (defined in bits 14:12 of this register) 11: from SPDIN (defined in bit 15 of this register)
1:0	R/W	Source loop back to the SPDOUT Left output 00: from DMA Channel-10 slot 9 01: from digital mixer monitor Left output 10: from PSDIN[X] (defined in bits 10:8 of this register) 11: from SPDIN (defined in bit 11 of this register)

MT34: Captured (Recorded) Data Routing Selection

Address Offset: 34 - 37h

Default Value: 00000000h.

Bit	Attribute	Description
31	R/W	SPDIN input loopback to PSDOUT[3] Right slot 1: SPDIN Right input 0: SPDIN Left input
30:28	R/W	PSDIN[X] loopback to PSDOUT[3] Right slot 000: PSDIN[0]: L 001: PSDIN[0]: R 010: PSDIN[1]: L 011: PSDIN[1]: R 100: PSDIN[2]: L 101: PSDIN[2]: R 110: PSDIN[3]: L 111: PSDIN[3]: R
27	R/W	SPDIN input loopback to PSDOUT[3] Left slot 1: SPDIN Right input 0: SPDIN Left input
26:24	R/W	PSDIN[X] loopback to PSDOUT[3] Left slot 000: PSDIN[0]: L 001: PSDIN[0]: R 010: PSDIN[1]: L 011: PSDIN[1]: R 100: PSDIN[2]: L 101: PSDIN[2]: R 110: PSDIN[3]: L 111: PSDIN[3]: R
23	R/W	SPDIN input loopback to PSDOUT[2] Right slot 1: SPDIN Right input 0: SPDIN Left input
22:20	R/W	PSDIN[X] loopback to PSDOUT[2] Right slot 000: PSDIN[0]: L 001: PSDIN[0]: R 010: PSDIN[1]: L 011: PSDIN[1]: R 100: PSDIN[2]: L 101: PSDIN[2]: R 110: PSDIN[3]: L 111: PSDIN[3]: R
19	R/W	SPDIN input loopback to PSDOUT[2] Left slot 1: S/PDIF right input 0: S/PDIF left input

Bit	Attribute	Description
18:16	R/W	PSDIN[X] loopback to PSDOUT[2] Left slot 000: PSDIN[0]: L 001: PSDIN[0]: R 010: PSDIN[1]: L 011: PSDIN[1]: R 100: PSDIN[2]: L 101: PSDIN[2]: R 110: PSDIN[3]: L 111: PSDIN[3]: R
15	R/W	SPDIN input loopback to PSDOUT[1] Right slot 1: SPDIN Right input 0: SPDIN Left input
14 : 12	R/W	PSDIN[X] loopback to PSDOUT[1] Right slot 000: PSDIN[0]: L 001: PSDIN[0]: R 010: PSDIN[1]: L 011: PSDIN[1]: R 100: PSDIN[2]: L 101: PSDIN[2]: R 110: PSDIN[3]: L 111: PSDIN[3]: R
11	R/W	PSDIN[X] loopback to PSDOUT[1] Left slot 1: S/PDIF right input 0: S/PDIF left input
10:8	R/W	PSDIN[X] loopback to PSDOUT[1] Left slot. 000: PSDIN[0]: L 001: PSDIN[0]: R 010: PSDIN[1]: L 011: PSDIN[1]: R 100: PSDIN[2]: L 101: PSDIN[2]: R 110: PSDIN[3]: L 111: PSDIN[3]: R
7	R/W	SPDIN input loopback to PSDOUT[0] Right slot 1: SPDIN Right input 0: SPDIN Left input
6:4	R/W	PSDIN[X] loopback to PSDOUT[0] Right slot 000: PSDIN[0]: L 001: PSDIN[0]: R 010: PSDIN[1]: L 011: PSDIN[1]: R 100: PSDIN[2]: L 101: PSDIN[2]: R 110: PSDIN[3]: L 111: PSDIN[3]: R
3	R/W	SPDIN input loopback to PSDOUT[0] Left slot 1: SPDIN Right input 0: SPDIN Left input

Bit	Attribute	Description
2:0	R/W	PSDIN[X] loopback to PSDOUT[0] Left slot 000: PSDIN[0]: L 001: PSDIN[0]: R 010: PSDIN[1]: L 011: PSDIN[1]: R 100: PSDIN[2]: L 101: PSDIN[2]: R 110: PSDIN[3]: L 111: PSDIN[3]: R

4.6.5 Multi-Track Digital Monitoring

The Envy24 integrates a 36-bit resolution digital hardware mixer. The width of the data path is strictly to ensure that during processing of all the channels, under any condition, no resolution is lost. The dynamic range of the end user system will be limited by the range of the physical output devices used. In order to maintain identical gain to the input stream (i.e. 0dB), the resulting 24-bit is not msb-aligned to the 36-bit. The overflow bits correspond to the analog distortion due to saturation. The user would need to reduce the overall attenuation of the inputs to avoid clipping. Insertion of the digital mixer adds only a single sample cycle delay with respect to the original data. This extremely low latency all digital mixer provides monitoring functionality and can replace a traditional external analog input mixer. There are 20 independent audio data streams to mix and control the volume. The output destination of this mixer can be the consumer AC '97 codec, an external DAC at PSDOUT[0] or SPDOUT or both simultaneously, as well as return to the host on slots 11 and 12 (the last two) of DMA Channel-11. Refer to the registers MT30, MT32, MT34 and MT3Ch in section 4.5.4 about audio data routing. Note that the consumer AC'97 path is limited to 48 KHz sampling rate maximum and for sub-48 KHz sampling rates, Channel-A and B of the DirectSound accelerator are allocated for SRC when the digital mixer return stream is at a sample rate other than 48 KHz. All other DirectSound streams operate concurrently without alterations.

MT38: Left / Right Volume Control Data

Address Offset: 38 - 39h

Default Value: 0707h

Refer to MT3A register for the audio data channel selection.

Bits	Attribute	Description
15	R0b	-
14:8	R/W	Right Volume control. Same format as the in the left volume control.
7	R0b	-
6:0	R/W	Left volume control. 0000000: 0dB 0000001: -1.5dB (0.841395141) 0000010: -3.0dB (0.7079458) 0000011: -4.5dB (0.5956621) 0000111: -10.5 dB (default) 0011111: -46.5dB 0111111: -94.5dB 1000000: -96dB 1100000: -144dB (maximum attenuation) 1111111: mute

MT3A: Volume Control Stream Index

Address Offset: 3Ah

Default Value: 00h

Bit	Attribute	Description
7:6	R00b	-
5:0	R/W	Index to select stream: 00000: Playback stream 1 (Channel-10 slot 1) 00001: Playback stream 2 (Channel-10 slot 2) 00010: Playback stream 3 (Channel-10 slot 3) 00011: Playback stream 4 (Channel-10 slot 4) 00100: Playback stream 5 (Channel-10 slot 5) 00101: Playback stream 6 (Channel-10 slot 6) 00110: Playback stream 7 (Channel-10 slot 7) 00111: Playback stream 8 (Channel-10 slot 8) 01000: Playback stream 9 (Channel-10 slot 9, typ. S/PDIF Left output stream) 01001: Playback stream 10 (Channel-10 slot 10, typ. S/PDIF Right output stream) 01010: Record stream 1 (Channel-11 slot 1) 01011: Record stream 2 (Channel-11 slot 2) 01100: Record stream 3 (Channel-11 slot 3) 01101: Record stream 4 (Channel-11 slot 4) 01110: Record stream 5 (Channel-11 slot 5) 01111: Record stream 6 (Channel-11 slot 6) 10000: Record stream 7 (Channel-11 slot 7) 10001: Record stream 8 (Channel-11 slot 8) 10010: Record stream 9 (Channel-11 slot 9, typ. S/PDIF Left input stream) 10011: Record stream 10 (Channel-11 slot 10, typ. S/PDIF Right input stream) others: ignored.

MT3B: Volume Control Rate

Address Offset: 3Bh

Default Value: 30h

Bits	Attribute	Description
7:0	R/W	Volume update rate control (sampling rate, PSYNC)

This register allows gradual change of the digital mixer volume setting. The value in MT3B specifies the number of samples to elapse (in hex) between each 1.5dB increment/decrement in volume mixer. This gradual volume update continues until the setting programmed into MT38 is reached. The appropriate value to program may vary, but 00 or 01h are good choices for most cases.

MT3C: Digital Mixer Monitor Routing Control

Address Offset: 3Ch

Default Value: 00h

Bits	Attribute	Description
7:6	R0	-
0	R/W	1: Route digital mixer output to the Consumer AC'97 path by allocating Channel-A and B.

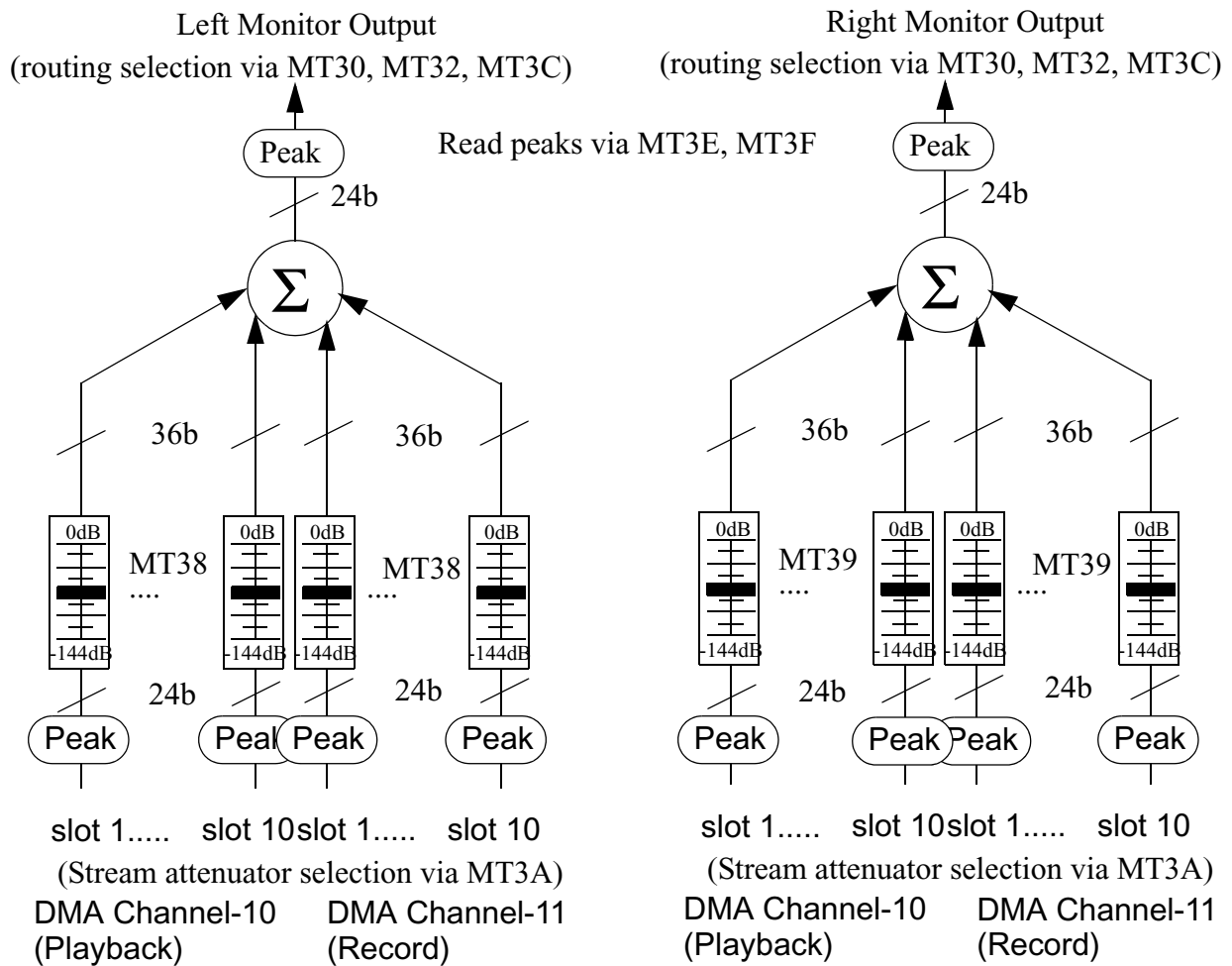

Figure 4-7. Digital Mixer Functional Diagram

MT3E: Peak Meter Index

Address Offset: 3Eh

Default Value: 00h

Bits	Attribute	Description
7:5	R000b	-
4:0	R/W	Peak meter stream index 00000: Playback stream 1 (Channel-10 slot 1) 00001: Playback stream 2 (Channel-10 slot 2) 00010: Playback stream 3 (Channel-10 slot 3) 00011: Playback stream 4 (Channel-10 slot 4) 00100: Playback stream 5 (Channel-10 slot 5) 00101: Playback stream 6 (Channel-10 slot 6) 00110: Playback stream 7 (Channel-10 slot 7) 00111: Playback stream 8 (Channel-10 slot 8) 01000: Playback stream 9 (Channel-10 slot 9, typ. S/PDIF Left output stream) 01001: Playback stream 10 (Channel-10 slot 10, typ. S/PDIF Right output stream) 01010: Record stream 1 (Channel-11 slot 1) 01011: Record stream 2 (Channel-11 slot 2) 01100: Record stream 3 (Channel-11 slot 3) 01101: Record stream 4 (Channel-11 slot 4) 01110: Record stream 5 (Channel-11 slot 5) 01111: Record stream 6 (Channel-11 slot 6) 10000: Record stream 7 (Channel-11 slot 7) 10001: Record stream 8 (Channel-11 slot 8) 10010: Record stream 9 (Channel-11 slot 9, typ. S/PDIF Left input stream) 10011: Record stream 10 (Channel-11 slot 10, typ. S/PDIF Right input stream) 10100: Record stream 11 (Channel-11 slot 11, typ. digital mixer monitor Left output stream) 10101: Record stream 12 (Channel-11 slot 12, typ. digital mixer monitor Right output stream) others: ignored.

MT3F: Peak Meter Data

Address Offset: 3Fh

Default Value: 00h

Bits	Attribute	Description
7:0	R	Peak data derived from the absolute value of 9 msb. 00h min - FFh max volume. Reading the register resets the meter to 00h.

Electrical Specifications

5.1 Maximum Ratings

Table 5-1. Maximum Ratings

Parameter	Min	Typ	Max	Unit
Storage Temperature	-55		150	°C
Operating Ambient Temperature	0	25	70	°C
DC Supply Voltage (Analog and Digital)	3.0	3.3	4.0	V
I/O Pin Voltage	GND - 0.5		VDD	V
Power Dissipation			TBD	W

5.2 Electrical Specifications

Table 5-2. DC Characteristics

($T_A=25^{\circ}\text{C}$, $V_{DD} = 3.3\text{V} \pm 5\%$; $GND = 0\text{V}$; 50pF Load)

Symbol	Parameter	Min	Typ	Max	Unit
V _{IN}	Input Voltage Range	-0.3		V _{DD} +0.3	V
V _{IL}	Input Low Voltage			0.3 x V _{DD}	V
V _{IH}	Input High Voltage	0.4 x V _{DD}			V
V _{OL}	Output Low Voltage			0.2 x V _{DD}	V
V _{OH}	Output High Voltage	0.5 x V _{DD}			V
–	Input Leakage Current	-10		10	μA
–	Output Leakage Current	-10		10	μA
–	Output Buffer Drive Current		TBD		mA

Table 5-3. Power Consumption

(TA=25°C, VDD = 3.3V ± 5%; GND = 0V; 50pF Load)

Symbol	Parameter	Min	Typ	Max	Unit
IVDD	Supply Current: Power Up		110		mA
IVDD	Supply Current: Partial Power Up		TBD		mA
IVDD	Supply Current: Partial Power Down		TBD		mA
IVDD	Supply Current: Power Down		TBD		mA

5.3 AC Timing Characteristics

(Test Conditions: TA=25°C, VDD = 3.3V ± 5%; GND = 0V; 50pF Load)

Table 5-4. Cold Reset

Symbol	Parameter	Min	Typ	Max	Unit
TRST_LOW	CRST#/PRST# Active Low Pulse Width	1			μs
TRST2CLK	CRST#/PRST# Inactive to CBLK/PBCLK/SPSCLK Startup Delay	162.8			ns

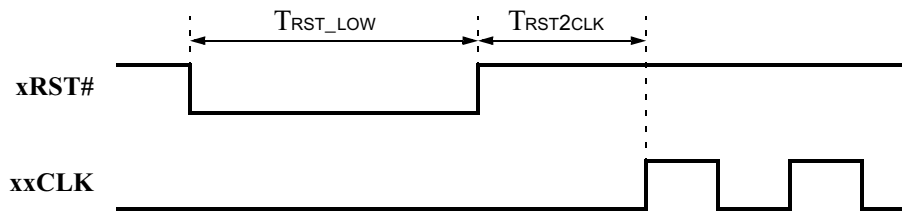

Figure 5-1. Cold Reset Timing

Table 5-5. Warm Reset

Symbol	Parameter	Min	Typ	Max	Unit
TSYNC_HIGH	CSYNC/PSYNC Active High Pulse Width		1.3		μ s
TSYNC2CLK	CSYNC/PSYNC Inactive to CBLK/PBCLK Startup Delay	162.8			ns

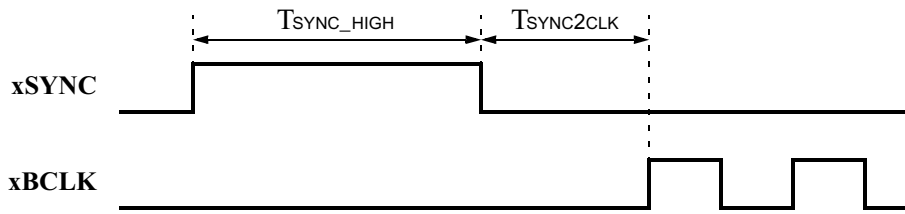

Figure 5-2. Warm Reset Timing

Table 5-6. Slave Mode Master clock delay

Symbol	Parameter	Min	Typ	Max	Unit
TSPI2MCK	SPMCKIN to PMCLK Delay		4		ns
TSPI2SPO	SPMCKIN to SPMCKOUT Delay		5.5		ns

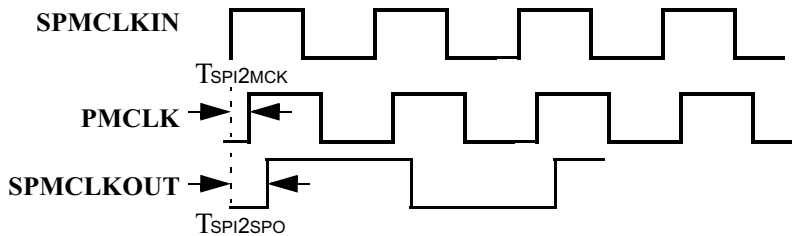

Figure 5-3. Master Clock Delay

Table 5-7. xBCLK / xxSYNC Timing

Symbol	Parameter	Min	Typ	Max	Unit
	xBCLK Frequency		see Appendix		MHz
TCLK_PERIOD	xBCLK Period		see Appendix		ns
	xBCLK Output Jitter		TBD	750	ps
TCLK_HIGH	xBCLK Pulse Width (high)		see Appendix		ns
TCLK_LOW	xBCLK Pulse Width (low)		see Appendix		ns
TCLK_DC	xBCLK Duty Cycle		see Appendix		%
	xxSYNC Frequency		see Appendix		kHz
TSYNC_PERIOD	xxSYNC Period		see Appendix		μ s
TSYNC_HIGH	xxSYNC Pulse Width (high)		see Appendix		μ s
TSYNC_LOW	xxSYNC Pulse Width (low)		see Appendix		μ s

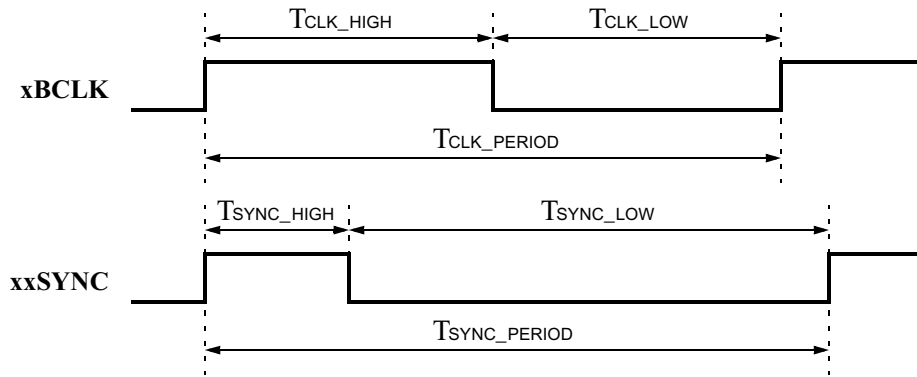

Figure 5-4. xBCLK to xxSYNC Timing

Table 5-8. Setup and Hold

Symbol	Parameter	Min	Typ	Max	Unit
TSETUP1	xSDOUT Setup to falling edge of xBCLK	15			ns
THOLD1	xSDOUT Hold from falling edge of xBCLK	5			ns
TSETUP2	xSYNC Setup to rising edge of xBCLK	15			ns
THOLD2	xSYNC Hold to rising edge of xBCLK	5			ns

Note: SDATA_IN seup and hold calculations determined by AC'97 controller propagation delay.

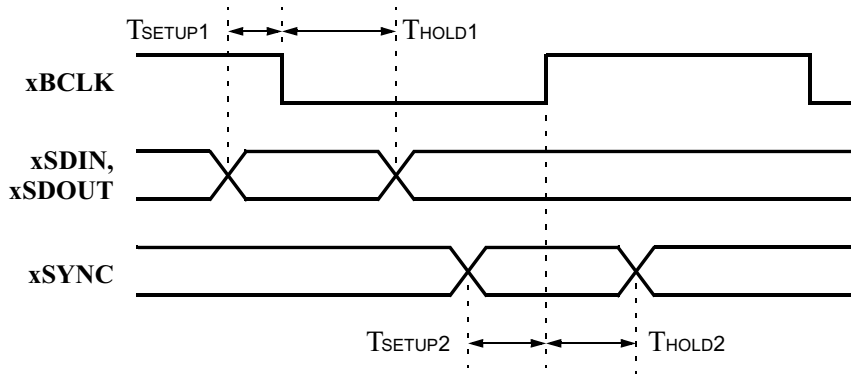

Figure 5-5. Setup and Hold Time

Table 5-9. Rise and Fall Time

Symbol	Parameter	Min	Typ	Max	Unit
TRISE	xBCLK rise time	2		6	ns
TFALL	xBCLK fall time	2		6	ns
TRISE	xxSYNC rise time	2		6	ns
TFALL	xxSYNC fall time	2		6	ns
TRISE	xSDIN rise time	2		6	ns
TFALL	xSDIN fall time	2		6	ns
TRISE	xSDOUT rise time	2		6	ns
TFALL	xSDOUT fall time	2		6	ns

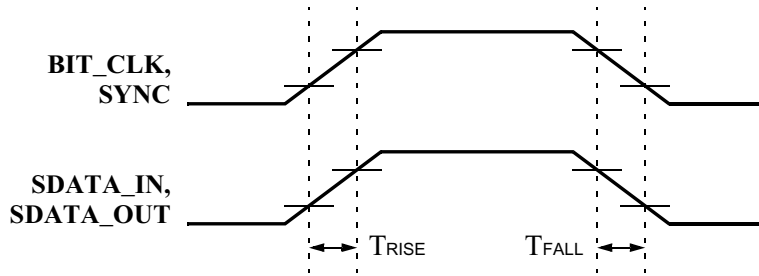

Figure 5-6. Rise Time and Fall Time

Table 5-10. AC-Link Low Power Mode

Symbol	Parameter	Min	Typ	Max	Unit
TS2_PDOWN	End of Slot 2 to CBCLK/PBCLK to CSDIN/PSDIN low			1	μ s

Note: CBCLK/PBCLK not to scale.

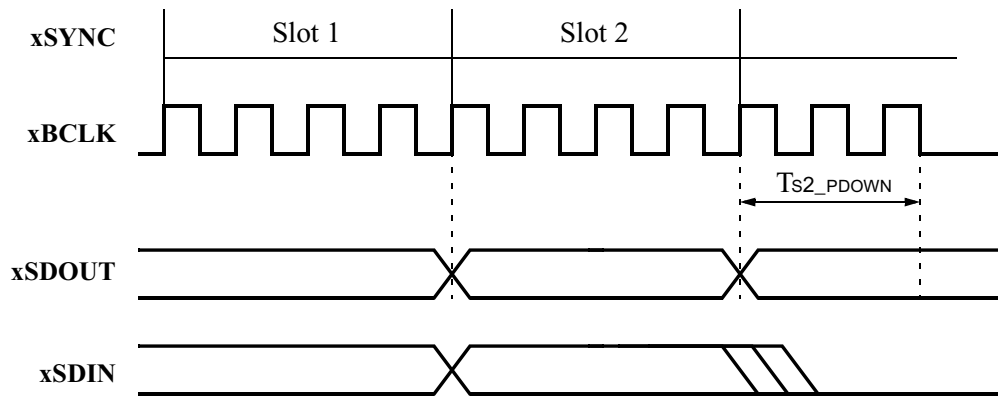

Figure 5-7. AC-Link Power Mode Timing

Mechanical Specifications

6.1 Thermal Specifications

Parameter	Min	Typ	Max	Unit
Thermal Resistenace θ_{JA} (Still Air)		TBD		°C/W
Junction Temperature		TBD		°C

6.2 Package Dimensions

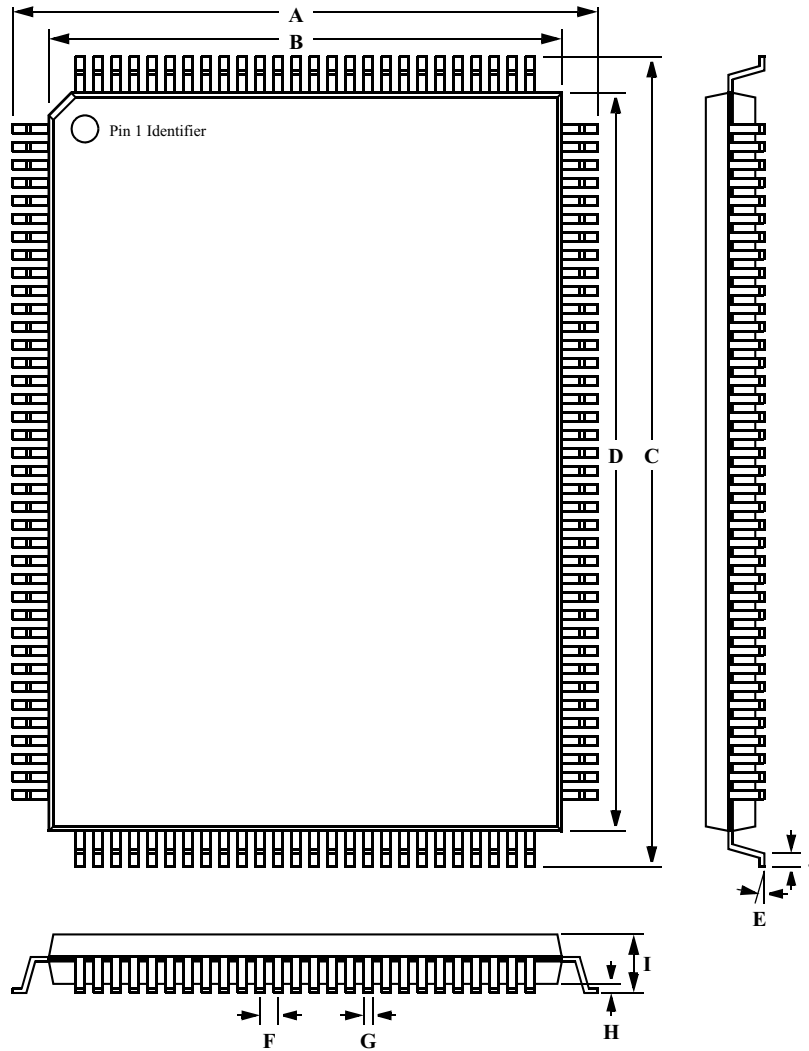

Table 6-1. Mechanical Dimensions

Symbol	A	B	C	D	E	F	G	H	I	J
minimum	17.0	13.9	23.0	19.9	0°	0.5	0.17	0.25	-	0.65
maximum	17.4	14.1	23.4	20.1	7°		0.23	-	3.4	0.95

Note: Dimensions are in millimeters, unless otherwise stated.

Appendix A

A.1 Appendix A

The following tables will help system designers and software developers correctly set the sampling rate and clock ratios. To determine via software whether AC-link or I²S converters are used, read back PCI61[7]. Based on the outcome either **Table A-1** or **Table A-2** should be used. To set the sampling rate, regardless of the converter type used, program MT01. MT02 will have no effect in AC-link mode. MT02 will set I²S interface bpf, oversampling rate, master clock to sampling rate ratio and similar characteristics. For a visual description of hardware settings refer to **Figure 4-4-3** and **Figure 4-4-4** on page 27 and page 28 of chapter 4 respectively .

Table A-1. AC-Link Interface Parameters and Ratios (Pin 50 Floating / Pulled Up)

PSYNC (SR in kHz)	PMCLK/PSYNC	XINx/PMCLK	PBCLK / PSYNC (bpf)
96	-	-	-
48	512	1	256
24	512	2	256
12	512	4	256
32	512	1.5*	256
16	512	3*	256
8	512	6	256
9.6	512	5*	256
44.1	512	1	256
22.05	512	2	256
11.025	512	4	256

Note: When using AC'97 codecs, the XIN2 must have 22.5792 MHz (512*44.1 KHz) to be able to support the sampling rates at 44.1 KHz and submultiples. The dividers marked with * at sampling rates 32 / 16 / 9.6 KHz, will not have 50% duty cycle PMCLK.

Table A-2. I²S Interface Parameters and Ratios (Pin 50 Pulled Down)

PSYNC (SR in kHz)	PMCLK/PSYNC	XINx/PMCLK	PBCLK / PSYNC (bpf)
96	128 or 256	2 or 1	64
64	128	3*	64
48	128 or 256	4 or 2	64
24	128 or 256	8 or 4	64
12	128 or 256	16 or 8	64
32	128 or 256	6 or 3*	64
16	128 or 256	12 or 6	64

Table A-2. I²S Interface Parameters and Ratios (Pin 50 Pulled Down)

PSYNC (SR in kHz)	PMCLK/PSYNC	XINx/PMCLK	PBCLK / PSYNC (bpf)
8	128 or 256	24 or 12	64
9.6	128 or 256	20 or 10	64
88.2	128 or 256	2 or 1	64
44.1	256 or 384	2 or 1	64 or 48
22.05	256 or 384	4 or 2	64 or 48
11.025	256 or 384	8 or 4	64 or 48

Note: Clock source either 22.5792 MHz for 512*44.1 KHz or 16.9344 MHz for 384*44.1 KHz, software controlled via PCI60[7-6]. For 512*48 KHz, the clock source is 24.576 MHz. The divider marked with * like the one at 32 KHz sampling rate, will not have 50% duty cycle PMCLK. See MT02 for I²S data format and clock ratios. 48 bpf is available for XIN2 originating clocks only.

Table A-3. S/PDIF Output I²S Interface Parameters and Ratios

SPSYNC (SR in kHz)	SPMCLKOUT/SPSYNC	SPSCLK/SPSYNC (bpf)
96	128	64
48	128	64
44.1	128	64
32	128	64

Note: Refer to CS8402A, CS8404A transmitters

Table A-4. S/PDIF Input I²S Interface Parameters and Ratios

SPSYNC (SR in kHz)	SPMCLKIN/SPSYNC	SPSCLK/SPSYNC (bpf)
96	256	64
48	256	64
44.1	256	64
32	256	64

Note: Refer to CS8412, CS8414 receivers. To set the controller into slave mode, set MT01[4]. When S/PDIF input is the master clock, 256x is the maximum PMCLK. This input can be used to synchronize with external Super Word Clock inputs. This can also be used to slave multiple PCI controllers in a single workstation.