

MC10ELT28, MC100ELT28

5 V TTL to Differential PECL and Differential PECL to TTL Translator



ON Semiconductor®

<http://onsemi.com>

Description

The MC10ELT/100ELT28 is a differential PECL to TTL translator and a TTL to differential PECL translator in a single package. Because PECL (Positive ECL) levels are used, only +5 V and ground are required. The small outline 8-lead package and the dual translation design of the ELT28 makes it ideal for applications which are sending and receiving signals across a backplane.

The 100 Series contains temperature compensation.

Features

- 3.5 ns Typical PECL to TTL Propagation Delay
- 1.2 ns Typical TTL to PECL Propagation Delay
- PNP TTL Inputs for Minimal Loading
- 24 mA TTL Outputs
- Flow Through Pinouts
- Operating Range $V_{CC} = 4.75 \text{ V to } 5.25 \text{ V}$ with $GND = 0 \text{ V}$
- Q_{TTL} Output Will Default High with Inputs Left Open or $< 1.3 \text{ V}$
- Q_{ECL} Output Will Default High with Inputs Left Open
- Internal PECL Input Pulldown Resistors
- Pb-Free Packages are Available

MARKING DIAGRAMS*



SOIC-8
D SUFFIX
CASE 751

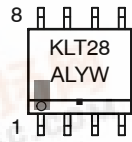
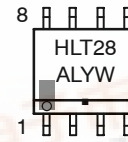

TSSOP-8
DT SUFFIX
CASE 948R

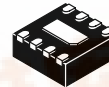
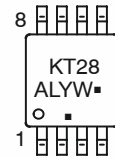

DFN8
MN SUFFIX
CASE 506AA

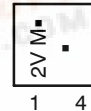
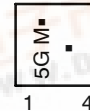

H = MC10	A = Assembly Location
K = MC100	L = Wafer Lot
5G = MC10	Y = Year
2V = MC100	W = Work Week
M = Date Code	▪ = Pb-Free Package

(Note: Microdot may be in either location)

*For additional marking information, refer to Application Note AND8002/D.

ORDERING INFORMATION

See detailed ordering and shipping information in the package dimensions section on page 6 of this data sheet.



MC10ELT28, MC100ELT28

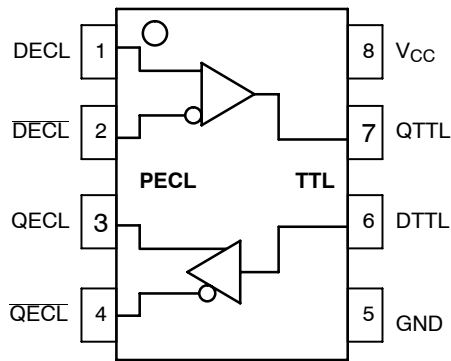

Figure 1. 8-Lead Pinout (Top View) and Logic Diagram

Table 1. PIN DESCRIPTION

Pin	Function
QTTL	TTL Outputs
DTTL	TTL Data Inputs
QECL, \overline{QECL}	PECL Differential Outputs
DECL, \overline{DECL}	PECL Differential Inputs
V _{CC}	Positive Supply
GND	Ground
EP	Exposed pad must be connected to a sufficient thermal conduit. Electrically connect to the most negative supply or leave floating open.

Table 2. ATTRIBUTES

Characteristics	Value	
ESD Protection Human Body Model	> 2 kV	
Moisture Sensitivity, Indefinite Time Out of Drypack (Note 1)	Pb Pkg	Pb-Free Pkg
	SOIC-8 TSSOP-8 DFN8	Level 1 Level 3 Level 1
Flammability Rating Oxygen Index: 28 to 34	UL 94 V-0 @ 0.125 in	
Transistor Count	71 Devices	
Meets or exceeds JEDEC Spec EIA/JESD78 IC Latchup Test		

1. For additional information, see Application Note AND8003/D.

Table 3. MAXIMUM RATINGS

Symbol	Parameter	Condition 1	Condition 2	Rating	Unit
V _{CC}	Positive Power Supply	GND = 0 V		7	V
V _{IN}	Input Voltage	GND = 0 V	V _I ≤ V _{CC}	0 to 6	V
I _{out}	PECL Output Current	Continuous Surge		50 100	mA mA
T _A	Operating Temperature Range			-40 to +85	°C
T _{stg}	Storage Temperature Range			-65 to +150	°C
θ _{JA}	Thermal Resistance (Junction-to-Ambient)	0 lfpm 500 lfpm	SOIC-8 SOIC-8	190 130	°C/W °C/W
θ _{JC}	Thermal Resistance (Junction-to-Case)	Standard Board	SOIC-8	41 to 44	°C/W
θ _{JA}	Thermal Resistance (Junction-to-Ambient)	0 lfpm 500 lfpm	TSSOP-8 TSSOP-8	185 140	°C/W °C/W
θ _{JC}	Thermal Resistance (Junction-to-Case)	Standard Board	TSSOP-8	41 to 44 ± 5%	°C/W
θ _{JA}	Thermal Resistance (Junction-to-Ambient)	0 lfpm 500 lfpm	DFN8 DFN8	129 84	°C/W °C/W
T _{sol}	Wave Solder	Pb Pb-Free	<2 to 3 sec @ 248°C <2 to 3 sec @ 260°C	265 265	°C

Stresses exceeding Maximum Ratings may damage the device. Maximum Ratings are stress ratings only. Functional operation above the Recommended Operating Conditions is not implied. Extended exposure to stresses above the Recommended Operating Conditions may affect device reliability.

MC10ELT28, MC100ELT28

Table 4. 10ELT SERIES PECL DC CHARACTERISTICS $V_{CC}= 5.0\text{ V}$; $GND= 0.0\text{ V}$ (Note 2)

Symbol	Characteristic	-40°C			25°C			85°C			Unit
		Min	Typ	Max	Min	Typ	Max	Min	Typ	Max	
V_{OH}	Output HIGH Voltage (Note 3)	3920	4010	4110	4020	4105	4190	4090	4185	4280	mV
V_{OL}	Output LOW Voltage (Note 3)	3050	3200	3350	3050	3210	3370	3050	3227	3405	mV
V_{IH}	Input HIGH Voltage (Single-Ended)	3770		4110	3870		4190	3940		4280	mV
V_{IL}	Input LOW Voltage (Single-Ended)	3050		3500	3050		3520	3050		3555	mV
V_{IHCMR}	Input HIGH Voltage Common Mode Range (Differential) (Note 4)	2.2		5.0	2.2		5.0	2.2		5.0	V
I_{IH}	Input HIGH Current			255			175			175	μA
I_{IL}	Input LOW Current	0.5			0.5			0.3			μA

NOTE: Device will meet the specifications after thermal equilibrium has been established when mounted in a test socket or printed circuit board with maintained transverse airflow greater than 500 lfm. Electrical parameters are guaranteed only over the declared operating temperature range. Functional operation of the device exceeding these conditions is not implied. Device specification limit values are applied individually under normal operating conditions and not valid simultaneously.

2. Input and output parameters vary 1:1 with V_{CC} . V_{CC} can vary $\pm 0.25\text{ V}$.
3. PECL outputs are terminated through a $50\ \Omega$ resistor to $V_{CC} - 2\text{ V}$.
4. V_{IHCMR} min varies 1:1 with GND , V_{IHCMR} max varies 1:1 with V_{CC} .

Table 5. 100ELT SERIES PECL DC CHARACTERISTICS $V_{CC}= 5.0\text{ V}$; $GND= 0.0\text{ V}$ (Note 5)

Symbol	Characteristic	-40°C			25°C			85°C			Unit
		Min	Typ	Max	Min	Typ	Max	Min	Typ	Max	
V_{OH}	Output HIGH Voltage (Note 6)	3915	3995	4120	3975	4045	4120	3975	4050	4120	mV
V_{OL}	Output LOW Voltage (Note 6)	3170	3305	3445	3190	3295	3380	3190	3295	3380	mV
V_{IH}	Input HIGH Voltage (Single-Ended)	3835		4120	3835		4120	3835		4120	mV
V_{IL}	Input LOW Voltage (Single-Ended)	3190		3525	3190		3525	3190		3525	mV
V_{IHCMR}	Input HIGH Voltage Common Mode Range (Differential) (Note 7)	2.2		5.0	2.2		5.0	2.2		5.0	V
I_{IH}	Input HIGH Current			255			175			175	μA
I_{IL}	Input LOW Current	0.5			0.5			0.5			μA

NOTE: Device will meet the specifications after thermal equilibrium has been established when mounted in a test socket or printed circuit board with maintained transverse airflow greater than 500 lfm. Electrical parameters are guaranteed only over the declared operating temperature range. Functional operation of the device exceeding these conditions is not implied. Device specification limit values are applied individually under normal operating conditions and not valid simultaneously.

5. Input and output parameters vary 1:1 with V_{CC} . V_{CC} can vary $\pm 0.25\text{ V}$.
6. PECL outputs are terminated through a $50\ \Omega$ resistor to $V_{CC} - 2\text{ V}$.
7. V_{IHCMR} min varies 1:1 with GND , V_{IHCMR} max varies 1:1 with V_{CC} .

Table 6. TTL OUTPUT DC CHARACTERISTICS $V_{CC} = 4.75\text{V}$ to 5.25V ; $T_A = -40^\circ\text{C}$ to 85°C

Symbol	Characteristic	Condition	Min	Typ	Max	Unit
V_{OH}	Output HIGH Voltage	$I_{OH} = -3.0\text{ mA}$	2.4			V
V_{OL}	Output LOW Voltage	$I_{OL} = 24\text{ mA}$			0.5	V
I_{CCH}	Power Supply Current			27	40	mA
I_{CCL}	Power Supply Current			29	42	mA
I_{OS}	Output Short Circuit Current		-150		-60	mA

NOTE: Device will meet the specifications after thermal equilibrium has been established when mounted in a test socket or printed circuit board with maintained transverse airflow greater than 500 lfm. Electrical parameters are guaranteed only over the declared operating temperature range. Functional operation of the device exceeding these conditions is not implied. Device specification limit values are applied individually under normal operating conditions and not valid simultaneously.

MC10ELT28, MC100ELT28

Table 7. TTL INPUT DC CHARACTERISTICS $V_{CC} = 4.75\text{ V to }5.25\text{ V}$; $T_A = -40^\circ\text{C to }85^\circ\text{C}$

Symbol	Characteristic	Condition	Min	Typ	Max	Unit
I_{IH}	Input HIGH Current	$V_{IN} = 2.7\text{ V}$			20	μA
I_{IHH}	Input HIGH Current	$V_{IN} = 7.0\text{ V}$			100	μA
I_{IL}	Input LOW Current	$V_{IN} = 0.5\text{ V}$			-0.6	mA
V_{IK}	Input Clamp Diode Voltage	$I_{IN} = -18\text{ mA}$			-1.2	V
V_{IH}	Input HIGH Voltage		2.0			V
V_{IL}	Input LOW Voltage				0.8	V

NOTE: Device will meet the specifications after thermal equilibrium has been established when mounted in a test socket or printed circuit board with maintained transverse airflow greater than 500 lfpm. Electrical parameters are guaranteed only over the declared operating temperature range. Functional operation of the device exceeding these conditions is not implied. Device specification limit values are applied individually under normal operating conditions and not valid simultaneously.

Table 8. AC CHARACTERISTICS $V_{CC} = 4.75\text{ V to }5.25\text{ V}$ (Note 8)

Symbol	Characteristic	-40°C			25°C			85°C			Unit
		Min	Typ	Max	Min	Typ	Max	Min	Typ	Max	
f_{max}	Maximum Toggle Frequency		TBD			100			TBD		MHz
t_{PLH}	Propagation Delay @ 1.5 V DECL to QTTL DTTL to QECL	2.0 0.6		5.5 1.2	2.0 0.9	1.2	5.5 1.5	2.0 0.6		5.5 1.35	ns
t_{PHL}	Propagation Delay @ 1.5 V DECL to QTTL DTTL to QECL	2.0 0.4		5.5 1.0	2.0 0.5	0.8	5.5 1.1	2.0 0.7		5.5 1.3	ns
t_r, t_f	Rise/Fall Times (20% – 80%) QECL	0.15		1.5	0.15		1.5	0.15		1.5	ns
V_{PP}	PECL Input Swing (Note 9)	200		1000	200		1000	200		1000	mV
t_r/t_f	Output Rise Time (10% – 90%) Output Fall Time (10% – 90%)					1.6 1.1					ns ns

NOTE: Device will meet the specifications after thermal equilibrium has been established when mounted in a test socket or printed circuit board with maintained transverse airflow greater than 500 lfpm. Electrical parameters are guaranteed only over the declared operating temperature range. Functional operation of the device exceeding these conditions is not implied. Device specification limit values are applied individually under normal operating conditions and not valid simultaneously.

8. $R_L = 500\ \Omega$ to GND and $C_L = 20\ \text{pF}$ to GND. Refer to Figure 2.

9. $V_{\text{PP}}(\text{min})$ is the minimum input swing for which AC parameters are guaranteed.

MC10ELT28, MC100ELT28

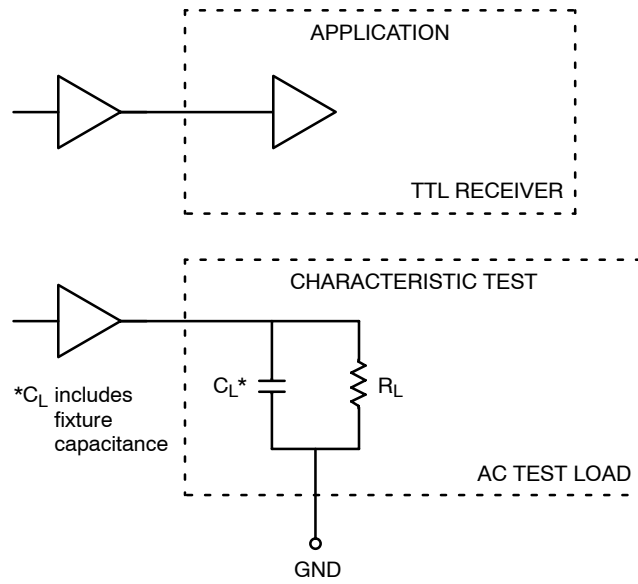

Figure 2. TTL Output Loading Used for Device Evaluation

MC10ELT28, MC100ELT28

ORDERING INFORMATION

Device	Package	Shipping [†]
MC10ELT28D	SOIC-8	98 Units / Rail
MC10ELT28DG	SOIC-8 (Pb-Free)	98 Units / Rail
MC10ELT28DR2	SOIC-8	2500 / Tape & Reel
MC10ELT28DR2G	SOIC-8 (Pb-Free)	2500 / Tape & Reel
MC10ELT28DT	TSSOP-8	100 Units / Rail
MC10ELT28DTG	TSSOP-8 (Pb-Free)	100 Units / Rail
MC10ELT28DTR2	TSSOP-8	2500 / Tape & Reel
MC10ELT28DTR2G	TSSOP-8 (Pb-Free)	2500 / Tape & Reel
MC10ELT28MNR4	DFN8	1000 / Tape & Reel
MC10ELT28MNR4G	DFN8 (Pb-Free)	1000 / Tape & Reel
MC100ELT28D	SOIC-8	98 Units / Rail
MC100ELT28DG	SOIC-8 (Pb-Free)	98 Units / Rail
MC100ELT28DR2	SOIC-8	2500 / Tape & Reel
MC100ELT28DR2G	SOIC-8 (Pb-Free)	2500 / Tape & Reel
MC100ELT28DT	TSSOP-8	100 Units / Rail
MC100ELT28DTG	TSSOP-8 (Pb-Free)	100 Units / Rail
MC100ELT28DTR2	TSSOP-8	2500 / Tape & Reel
MC100ELT28DTR2G	TSSOP-8 (Pb-Free)	2500 / Tape & Reel
MC100ELT28MNR4	DFN8	1000 / Tape & Reel
MC100ELT28MNR4G	DFN8 (Pb-Free)	1000 / Tape & Reel

[†]For information on tape and reel specifications, including part orientation and tape sizes, please refer to our Tape and Reel Packaging Specifications Brochure, BRD8011/D.

Resource Reference of Application Notes

- AN1405/D** – ECL Clock Distribution Techniques
- AN1406/D** – Designing with PECL (ECL at +5.0 V)
- AN1503/D** – ECLinPS™ I/O SPICE Modeling Kit
- AN1504/D** – Metastability and the ECLinPS Family
- AN1568/D** – Interfacing Between LVDS and ECL
- AN1672/D** – The ECL Translator Guide
- AND8001/D** – Odd Number Counters Design
- AND8002/D** – Marking and Date Codes
- AND8020/D** – Termination of ECL Logic Devices
- AND8066/D** – Interfacing with ECLinPS
- AND8090/D** – AC Characteristics of ECL Devices

MC10ELT28, MC100ELT28

PACKAGE DIMENSIONS

SOIC-8 NB
CASE 751-07
ISSUE AH

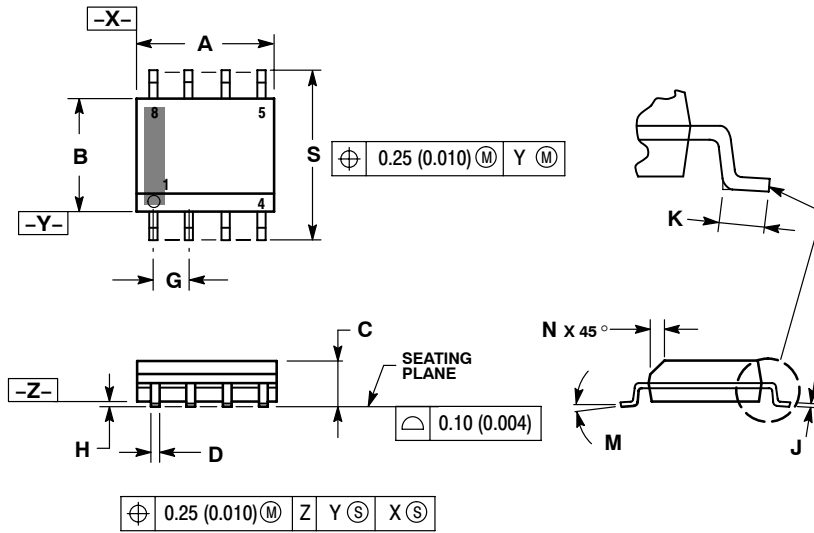

NOTES:

1. DIMENSIONING AND TOLERANCING PER ANSI Y14.5M, 1982.
2. CONTROLLING DIMENSION: MILLIMETER.
3. DIMENSION A AND B DO NOT INCLUDE MOLD PROTRUSION.
4. MAXIMUM MOLD PROTRUSION 0.15 (0.006) PER SIDE.
5. DIMENSION D DOES NOT INCLUDE DAMBAR PROTRUSION. ALLOWABLE DAMBAR PROTRUSION SHALL BE 0.127 (0.005) TOTAL IN EXCESS OF THE D DIMENSION AT MAXIMUM MATERIAL CONDITION.
6. 751-01 THRU 751-06 ARE OBSOLETE. NEW STANDARD IS 751-07.

DIM	MILLIMETERS		INCHES	
	MIN	MAX	MIN	MAX
A	4.80	5.00	0.189	0.197
B	3.80	4.00	0.150	0.157
C	1.35	1.75	0.053	0.069
D	0.33	0.51	0.013	0.020
G	1.27 BSC		0.050 BSC	
H	0.10	0.25	0.004	0.010
J	0.19	0.25	0.007	0.010
K	0.40	1.27	0.016	0.050
M	0°	8°	0°	8°
N	0.25	0.50	0.010	0.020
S	5.80	6.20	0.228	0.244

SOLDERING FOOTPRINT*

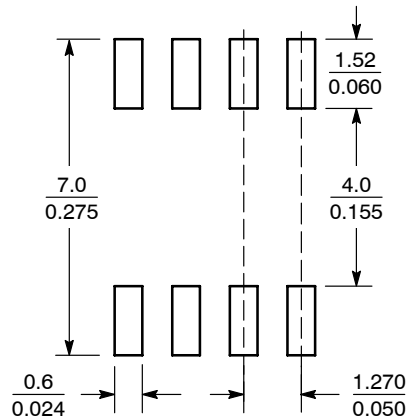

SCALE 6:1 $\left(\frac{\text{mm}}{\text{inches}} \right)$

*For additional information on our Pb-Free strategy and soldering details, please download the ON Semiconductor Soldering and Mounting Techniques Reference Manual, SOLDERRM/D.

MC10ELT28, MC100ELT28

PACKAGE DIMENSIONS

TSSOP-8
DT SUFFIX
PLASTIC TSSOP PACKAGE
CASE 948R-02
ISSUE A

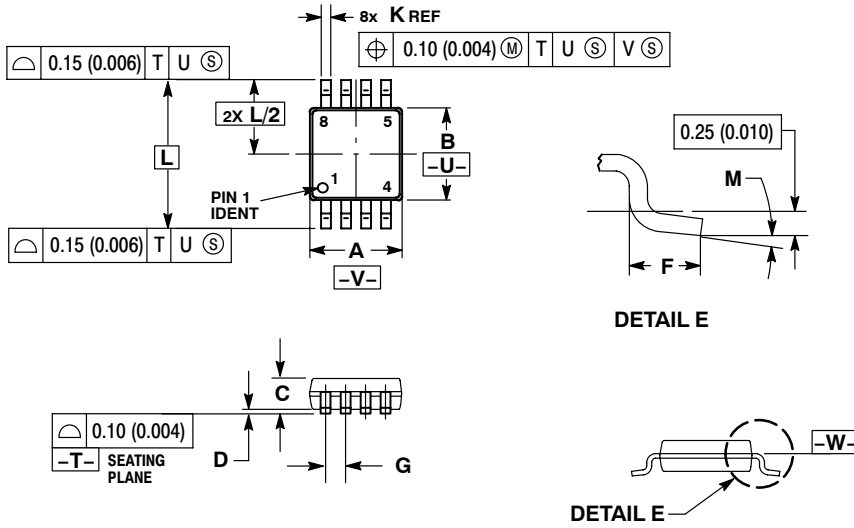

NOTES:

1. DIMENSIONING AND TOLERANCING PER ANSI Y14.5M, 1982.
2. CONTROLLING DIMENSION: MILLIMETER.
3. DIMENSION A DOES NOT INCLUDE MOLD FLASH, PROTRUSIONS OR GATE BURRS. MOLD FLASH OR GATE BURRS SHALL NOT EXCEED 0.15 (0.006) PER SIDE.
4. DIMENSION B DOES NOT INCLUDE INTERLEAD FLASH OR PROTRUSION. INTERLEAD FLASH OR PROTRUSION SHALL NOT EXCEED 0.25 (0.010) PER SIDE.
5. TERMINAL NUMBERS ARE SHOWN FOR REFERENCE ONLY.
6. DIMENSION A AND B ARE TO BE DETERMINED AT DATUM PLANE -W-.

DIM	MILLIMETERS		INCHES	
	MIN	MAX	MIN	MAX
A	2.90	3.10	0.114	0.122
B	2.90	3.10	0.114	0.122
C	0.80	1.10	0.031	0.043
D	0.05	0.15	0.002	0.006
F	0.40	0.70	0.016	0.028
G	0.65 BSC		0.026 BSC	
K	0.25	0.40	0.010	0.016
L	4.90 BSC		0.193 BSC	
M	0°	6°	0°	6°

MC10ELT28, MC100ELT28

PACKAGE DIMENSIONS

DFN8
CASE 506AA-01
ISSUE D

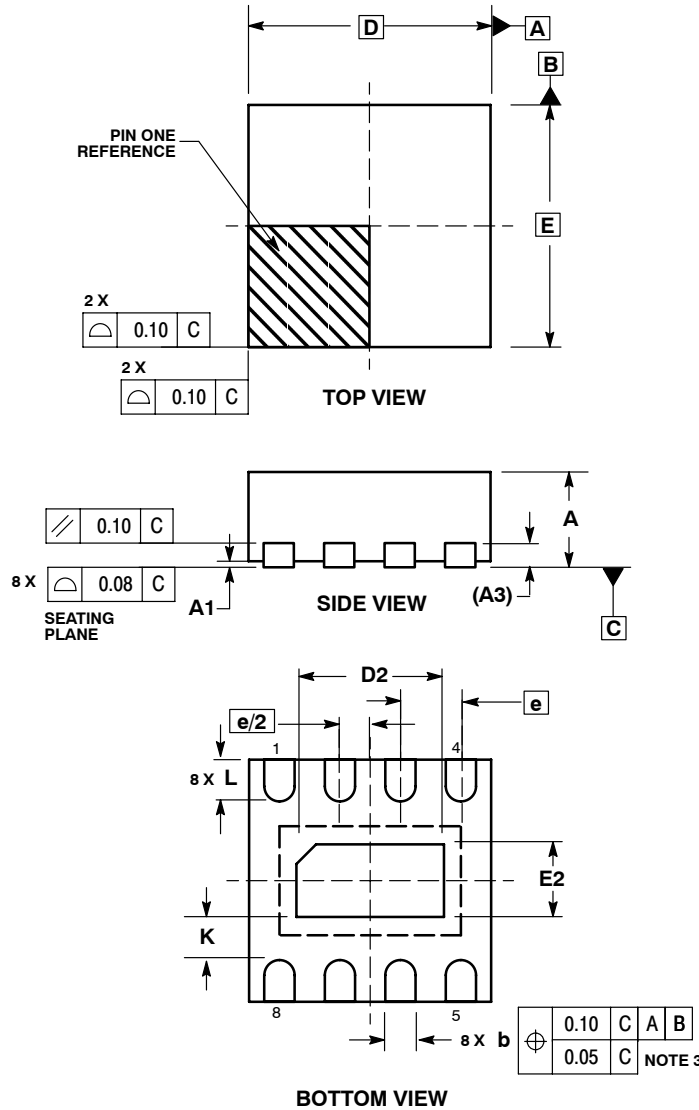

NOTES:

1. DIMENSIONING AND TOLERANCING PER ASME Y14.5M, 1994 .
2. CONTROLLING DIMENSION: MILLIMETERS.
3. DIMENSION b APPLIES TO PLATED TERMINAL AND IS MEASURED BETWEEN 0.25 AND 0.30 MM FROM TERMINAL.
4. COPLANARITY APPLIES TO THE EXPOSED PAD AS WELL AS THE TERMINALS.

DIM	MILLIMETERS	
	MIN	MAX
A	0.80	1.00
A1	0.00	0.05
A3	0.20 REF	
b	0.20	0.30
D	2.00 BSC	
D2	1.10	1.30
E	2.00 BSC	
E2	0.70	0.90
e	0.50 BSC	
K	0.20	---
L	0.25	0.35

ECLinPS is a trademark of Semiconductor Components Industries, LLC (SCILLC).

ON Semiconductor and  are registered trademarks of Semiconductor Components Industries, LLC (SCILLC). SCILLC reserves the right to make changes without further notice to any products herein. SCILLC makes no warranty, representation or guarantee regarding the suitability of its products for any particular purpose, nor does SCILLC assume any liability arising out of the application or use of any product or circuit, and specifically disclaims any and all liability, including without limitation special, consequential or incidental damages. "Typical" parameters which may be provided in SCILLC data sheets and/or specifications can and do vary in different applications and actual performance may vary over time. All operating parameters, including "Typicals" must be validated for each customer application by customer's technical experts. SCILLC does not convey any license under its patent rights nor the rights of others. SCILLC products are not designed, intended, or authorized for use as components in systems intended for surgical implant into the body, or other applications intended to support or sustain life, or for any other application in which the failure of the SCILLC product could create a situation where personal injury or death may occur. Should Buyer purchase or use SCILLC products for any such unintended or unauthorized application, Buyer shall indemnify and hold SCILLC and its officers, employees, subsidiaries, affiliates, and distributors harmless against all claims, costs, damages, and expenses, and reasonable attorney fees arising out of, directly or indirectly, any claim of personal injury or death associated with such unintended or unauthorized use, even if such claim alleges that SCILLC was negligent regarding the design or manufacture of the part. SCILLC is an Equal Opportunity/Affirmative Action Employer. This literature is subject to all applicable copyright laws and is not for resale in any manner.

PUBLICATION ORDERING INFORMATION

LITERATURE FULFILLMENT:

Literature Distribution Center for ON Semiconductor
P.O. Box 5163, Denver, Colorado 80217 USA
Phone: 303-675-2175 or 800-344-3860 Toll Free USA/Canada
Fax: 303-675-2176 or 800-344-3867 Toll Free USA/Canada
Email: orderlit@onsemi.com

N. American Technical Support: 800-282-9855 Toll Free
USA/Canada
Europe, Middle East and Africa Technical Support:
Phone: 421 33 790 2910
Japan Customer Focus Center
Phone: 81-3-5773-3850

ON Semiconductor Website: www.onsemi.com

Order Literature: <http://www.onsemi.com/orderlit>

For additional information, please contact your local Sales Representative