

## SD 197-70-74-591

### Cooled Large Area Blue Silicon Avalanche Photodiode

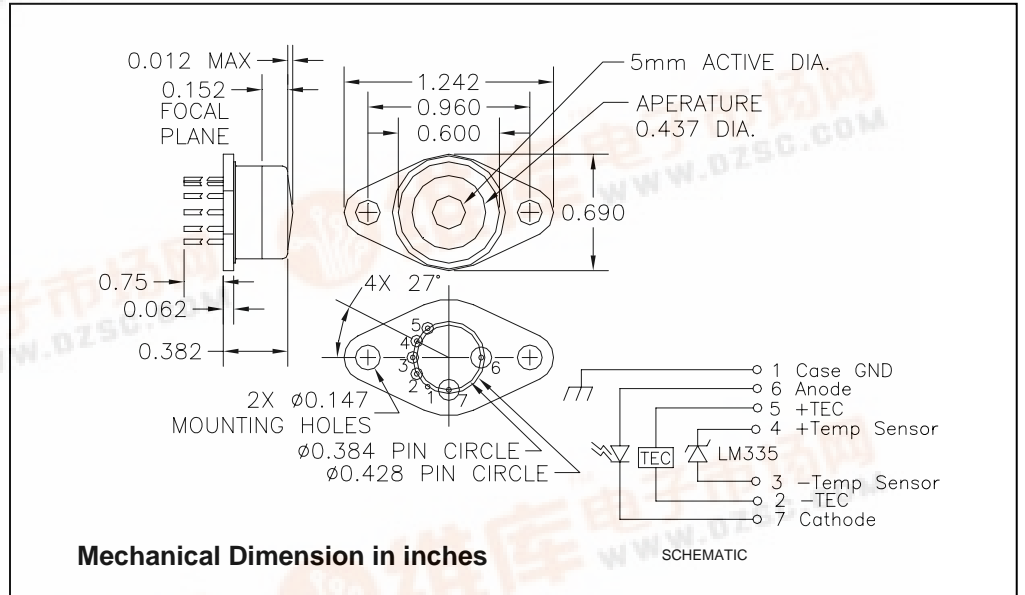

#### FEATURES

- Low noise
- Small size
- High Speed
- Low cost

#### DESCRIPTION

The **SD 197-70-74-591** is a cooled large area silicon avalanche photodiode (APD) that provides high gain and low noise, in a hermetic TO-66 package.

#### APPLICATIONS

- Military
- Industrial
- Medical

#### ABSOLUTE MAXIMUM RATING (TA)= 23°C UNLESS OTHERWISE NOTED

SYMBOL	PARAMETER	MIN	MAX	UNITS
M	Gain		350	
T <sub>STG</sub>	Storage Temperature	-55	+70	°C
T <sub>O</sub>	Operating Temperature	+1	+40	°C
T <sub>S</sub>	Soldering Temperature*		+240	°C
V <sub>TEC</sub>	TEC voltage		1.5	V
I <sub>TEC</sub>	TEC Current		2.0	A
P	APD Die Power Diss.		0.2	W

\* 1/16 inch from case for 3 seconds max.

#### SPECTRAL RESPONSE M = 300

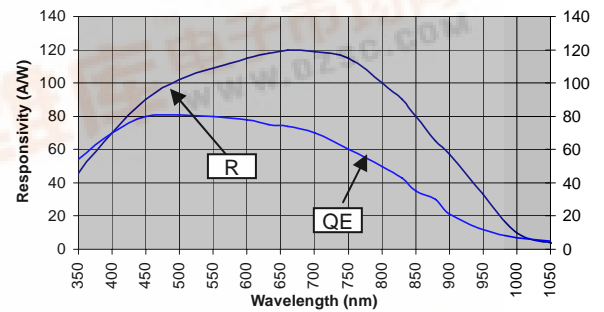

#### ELECTRO-OPTICAL CHARACTERISTICS RATING (TA)= 23°C UNLESS OTHERWISE NOTED

SYMBOL	CHARACTERISTIC	TEST CONDITIONS	MIN	TYP	MAX	UNITS
I <sub>D</sub>	Dark Current			6	18	nA
C <sub>J</sub>	Junction Capacitance	f = 1 MHz		25		pF
I <sub>N</sub>	Noise Current Spectral Density	f = 100 kHz		0.8	1.5	pA/√Hz
λ range	Spectral Application Range	Spot Scan	350		1050	nm
R	Responsivity	λ = 500nm, V <sub>R</sub> = 0 V		35		A/W
V <sub>op</sub>	Operating voltage		1700		2000	V
t <sub>r</sub>	Response Time**	RL = 50 Ω, λ = 675nm		10	15	nS
I <sub>QTEC</sub>	TEC Quiescent Current	Case Temp = 35 °C		0.85		A

\*\*Response time of 10% to 90% is specified at 830nm wavelength light.  
All specifications are with the APD internally cooled to 0°C and a gain of 300.

Information in this technical datasheet is believed to be correct and reliable. However, no responsibility is assumed for possible inaccuracies or omission. Specifications are subject to change without notice.