



GM7800 SERIES

POSITIVE VOLTAGE REGULATORS

Description

The GM7800 series are classic regulators, which are useful in a wide range of applications. For example, you can use them for local on-card regulation to eliminate the distribution and problems associated with single point regulation.

The wide range of output voltages (5V to 27V) make them useful in an endless list of applications. Although designed as fixed voltage regulators, you can add a few external components to make adjustable voltages and currents.

Current limiting prevents the peak output current to a safe value. Safe-area protection of the output transistor limits internal power dissipation. If internal power dissipation becomes too high for the heat sinking provided, the thermal shutdown circuit activates to prevent the regulator from overheating. These versatile workhorses are easy to use. You do not need to bypass the output, although this does improve transient response. Input bypass is needed only if you place the regulator far from the filter capacitor of the power supply.

The GM7800 series is available in TO-220, TO-252 and TO-263 packages.

Features

- ◆ Output current up to 1.5A
- ◆ Output Voltages 5V, 6V, 8V, 8.5V, 9V, 10V, 12V, 15V, 18V, 20V, 24V and 27V
- ◆ 3- Terminal Regulators
- ◆ Internal Thermal Overload Protection
- ◆ Internal Short-Circuit Current Limiting
- ◆ Output Transistor Safe-Area Protection
- ◆ TO-220, TO-252 and TO-263 Packages
- ◆ High Power Dissipation Capability
- ◆ Direct replacements for LM78xx

Application

Post-Regulator Switching DC/DC Converters

Bias Supply for Analog Circuits

Instrumentation and Audio Systems

Logic Systems

Others too numerous to mention

TYPIC APPLICATION CIRCUITS

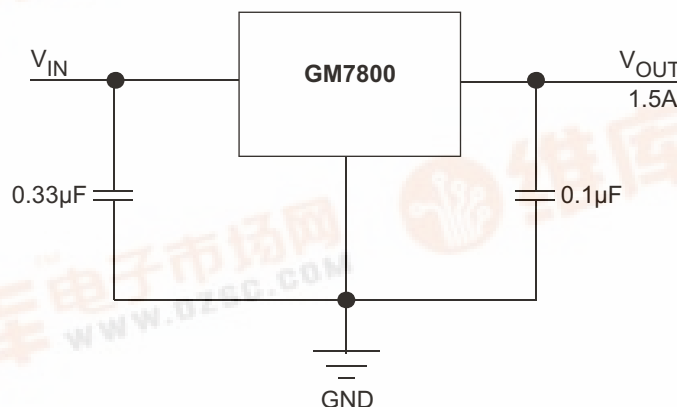

For a positive regulator, a 0.33µF bypass capacitor should be used on the input terminals. While not necessary for stability, an output capacitor of 0.1µF may be used to improve the transient response of the regulator. These capacitors should be on or as near as possible to the regulator terminals.



◆ MARKING INFORMATION & PIN CONFIGURATIONS (TOP VIEW)

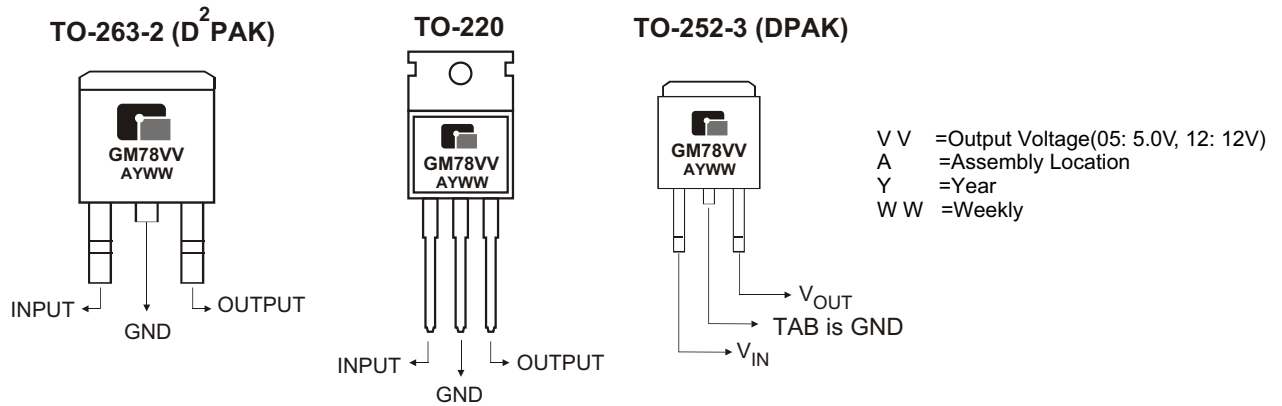

◆ ORDERING INFORMATION

Pro Number	V _{OUT}	Package
GM7805	5.0V	TO-263, TO-220, TO-252
GM7806	6.0V	TO-263, TO-220, TO-252
GM7808	8.0V	TO-263, TO-220, TO-252
GM7885	8.5V	TO-263, TO-220, TO-252
GM7809	9.0V	TO-263, TO-220, TO-252
GM7810	10V	TO-263, TO-220, TO-252
GM7812	12V	TO-263, TO-220, TO-252
GM7815	15V	TO-263, TO-220, TO-252
GM7818	18V	TO-263, TO-220, TO-252
GM7820	20V	TO-263, TO-220, TO-252
GM7824	24V	TO-263, TO-220, TO-252
GM7827	27V	TO-263, TO-220, TO-252

* For detail Ordering Number identification, please see last page.

◆ RECOMMENDED OPERATING CONDITIONS (I_O= 1.5A)

PARAMETER		MIN	MAX	UNIT
Input Voltage V _I	GM7805	7	25	V
	GM7806	8	25	
	GM7808	10.5	25	
	GM7885	10.5	25	
	GM7809	11.5	27	
	GM7810	12.5	28	
	GM7812	14.5	30	
	GM7815	17.5	30	
	GM7818	21	33	
	GM7820	23	36	
	GM7824	27	38	
GM7827	30	40		
Output Current, I _O			1.5	A
Operating virtual junction temperature, T _J		0	125	°C

◆ ABSOLUTE MAXIMUM RATINGS

PARAMETER	VALUE	UNIT
Input Voltage	GM7824, GM7827	40
	All others	35
Continuous Total Dissipation at 25°C free-air temperature	2	W
Continuous Total Dissipation at (or below) 25°C case Temperature	15	
Operating free-air, case, or virtual junctions Temperature Range	0 to +150	°C
Storage Temperature Range	-65 to +150	
Lead Temperature 1.6mm (1/16 inch) from case for 10seconds	260	

◆ SCHEMATIC BLOCK DIAGRAM

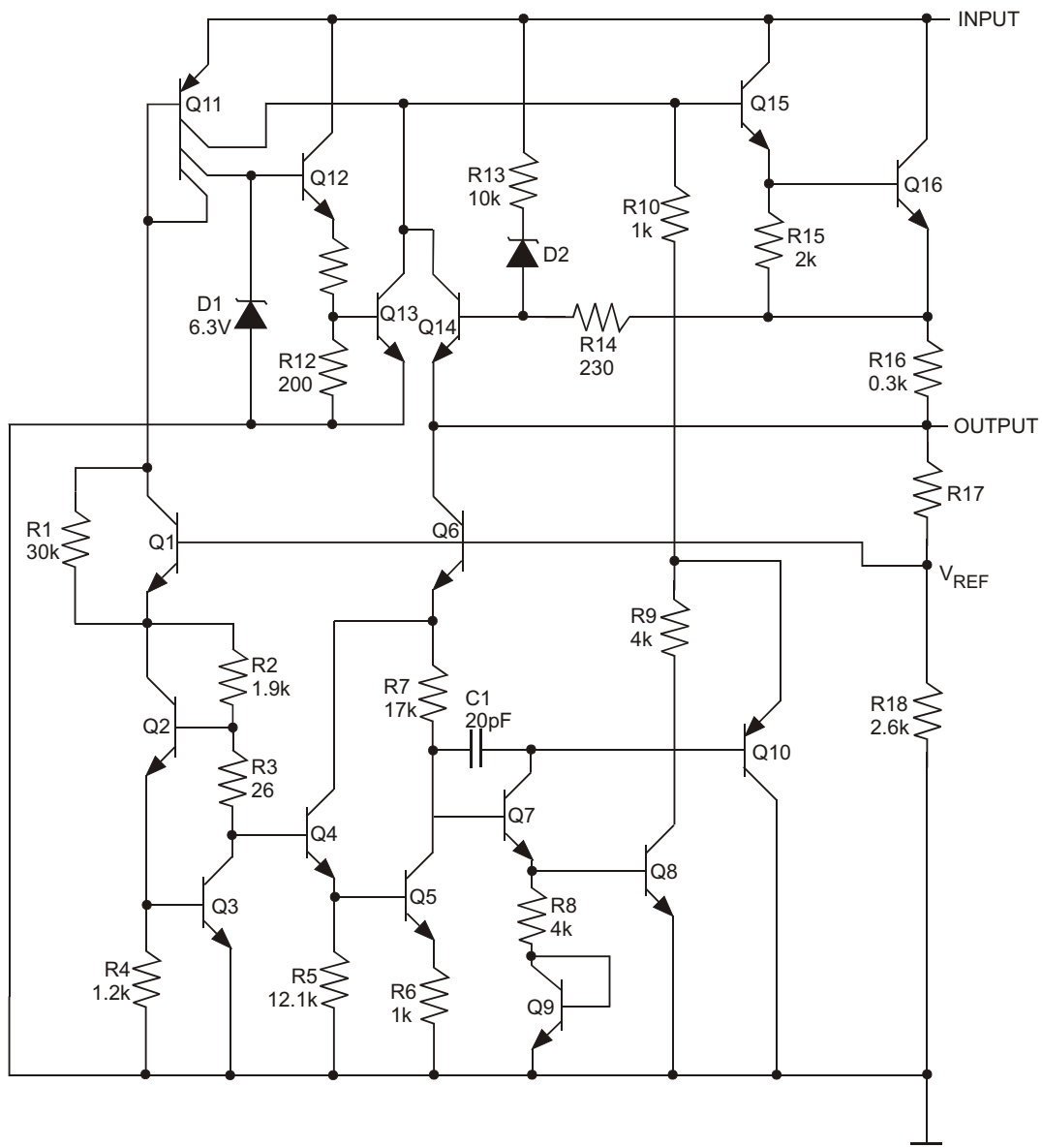

◆ ELECTRICAL CHARACTERISTICS at specified Junction Temperature

GM7805: $V_I = 10V$, $I_O = 500mA$, (unless otherwise noted)

CHARACTERISTICS	TEST CONDITIONS *		MIN	TYP	MAX	UNIT
Output Voltage **		25°C	4.8	5.0	5.2	V
	$I_O = 5mA$ to 1A $V_I = 7V$ to 20V, $P \leq 15W$	0°C to 125°C	4.75	5.0	5.25	
Input Regulation	$V_I = 7V$ to 25V	25°C		3	100	mV
	$V_I = 8V$ to 12V			1	50	
Ripple Rejection	$V_I = 8V$ to 18V, $f = 120Hz$	0°C to 125°C	62	78		dB
Output Regulation	$I_O = 5mA$ to 1.5A	25°C		15	100	mV
	$I_O = 250mA$ to 750mA			5	50	
Output Resistance	$f = 1kHz$	0°C to 125°C		0.017		
Temperature Coefficient Output Voltage	$I_O = 5mA$	0°C to 125°C		-1.1		mV/°C
Output Noise Voltage	$f = 10Hz$ to 100kHz	25°C		40		µV
Dropout Voltage	$I_O = 1A$	25°C		2.0		V
Bias Current		25°C		4.2	8	mA
Bias Current Change	$V_I = 7V$ to 25V	0°C to 125°C			1.3	mA
	$I_O = 5mA$ to 1A				0.5	
Short-Circuit Output Current		25°C		750		mA
Peak Output Current		25°C		2.2		A

GM7806: $V_I = 11V$, $I_O = 500mA$, (unless otherwise noted)

CHARACTERISTICS	TEST CONDITIONS *		MIN	TYP	MAX	UNIT
Output Voltage **		25°C	5.75	6	6.25	V
	$I_O = 5mA$ to 1A $V_I = 8V$ to 21V, $P \leq 15W$	0°C to 125°C	5.7	6	6.3	
Input Regulation	$V_I = 8V$ to 25V	25°C		5	120	mV
	$V_I = 9V$ to 13V			1.5	60	
Ripple Rejection	$V_I = 9V$ to 19V, $f = 120Hz$	0°C to 125°C	59	75		dB
Output Regulation	$I_O = 5mA$ to 1.5A	25°C		14	120	mV
	$I_O = 250mA$ to 750mA			4	60	
Output Resistance	$f = 1kHz$	0°C to 125°C		0.019		
Temperature Coefficient Output Voltage	$I_O = 5mA$	0°C to 125°C		-0.8		mV/°C
Output Noise Voltage	$f = 10Hz$ to 100kHz	25°C		45		µV
Dropout Voltage	$I_O = 1A$	25°C		2.0		V
Bias Current		25°C		4.3	8	mA
Bias Current Change	$V_I = 8V$ to 25V	0°C to 125°C			1.3	mA
	$I_O = 5mA$ to 1A				0.5	
Short-Circuit Output Current		25°C		550		mA
Peak Output Current		25°C		2.2		A

*Pulse testing techniques are used to maintain the junction temperature as close to the ambient temperature as possible. Thermal effects must be taken into account.

** The specification applies only for DC power dissipation permitted by absolute maximum ratings

◆ ELECTRICAL CHARACTERISTICS at specified Junction Temperature

GM7808: $V_I=14V$, $I_O=500mA$, (unless otherwise noted)

CHARACTERISTICS	TEST CONDITIONS *	MIN	TYP	MAX	UNIT	
Output Voltage **		25°C	7.7	8	8.3	V
	$I_O=5mA$ to 1A $V_I=10.5V$ to 23V, $P \leq 15W$	0°C to 125°C	7.6	8	8.4	
Input Regulation	$V_I=10.5V$ to 25V	25°C		6	160	mV
	$V_I=11V$ to 17V			2	80	
Ripple Rejection	$V_I=11.5V$ to 21.5V, $f = 120Hz$	0°C to 125°C	55	72		dB
Output Regulation	$I_O=5mA$ to 1.5A	25°C		12	160	mV
	$I_O=250mA$ to 750mA			4	80	
Output Resistance	$f = 1kHz$	0°C to 125°C		0.016		
Temperature Coefficient Output Voltage	$I_O=5mA$	0°C to 125°C		-0.8		mV/°C
Output Noise Voltage	$f = 10Hz$ to 100kHz	25°C		52		μV
Dropout Voltage	$I_O=1A$	25°C		2.0		V
Bias Current		25°C		4.3	8	mA
Bias Current Change	$V_I=10.5V$ to 25V	0°C to 125°C			1.0	mA
	$I_O=5mA$ to 1A				0.5	
Short-Circuit Output Current		25°C		450		mA
Peak Output Current		25°C		2.2		A

GM7885: $V_I=15V$, $I_O=500mA$, (unless otherwise noted)

CHARACTERISTICS	TEST CONDITIONS *	MIN	TYP	MAX	UNIT	
Output Voltage **		25°C	8.15	8.5	8.85	V
	$I_O=5mA$ to 1A $V_I=11.5V$ to 23.5V, $P \leq 15W$	0°C to 125°C	8.1	8.5	8.9	
Input Regulation	$V_I=10.5V$ to 25V	25°C		6	170	mV
	$V_I=11V$ to 17V			2	85	
Ripple Rejection	$V_I=11.5V$ to 21.5V, $f = 120Hz$	0°C to 125°C	54	70		dB
Output Regulation	$I_O=5mA$ to 1.5A	25°C		12	170	mV
	$I_O=250mA$ to 750mA			4	85	
Output Resistance	$f = 1kHz$	0°C to 125°C		0.016		
Temperature Coefficient Output Voltage	$I_O=5mA$	0°C to 125°C		-0.8		mV/°C
Output Noise Voltage	$f = 10Hz$ to 100kHz	25°C		55		μV
Dropout Voltage	$I_O=1A$	25°C		2.0		V
Bias Current		25°C		4.3	8	mA
Bias Current Change	$V_I=10.5V$ to 25V	0°C to 125°C			1.0	mA
	$I_O=5mA$ to 1A				0.5	
Short-Circuit Output Current		25°C		450		mA
Peak Output Current		25°C		2.2		A

*Pulse testing techniques are used to maintain the junction temperature as close to the ambient temperature as possible. Thermal effects must be taken into account.

** The specification applies only for DC power dissipation permitted by absolute maximum ratings

◆ ELECTRICAL CHARACTERISTICS at specified Junction Temperature

GM7809: $V_i=16V$, $I_o=500mA$, (unless otherwise noted)

CHARACTERISTICS	TEST CONDITIONS *		MIN	TYP	MAX	UNIT
Output Voltage **		25°C	8.65	9	9.35	V
	$I_o=5mA$ to 1A $V_i=11.5V$ to 24V, $P \leq 15W$	0°C to 125°C	8.55	9	9.45	
Input Regulation	$V_i=11.5V$ to 27V	25°C		7	180	mV
	$V_i=13V$ to 19V			2	90	
Ripple Rejection	$V_i=12V$ to 22V, $f = 120Hz$	0°C to 125°C	55	70		dB
Output Regulation	$I_o=5mA$ to 1.5A	25°C		12	180	mV
	$I_o=250mA$ to 750mA			4	90	
Output Resistance	$f = 1kHz$	0°C to 125°C		0.018		
Temperature Coefficient Output Voltage	$I_o=5mA$	0°C to 125°C		-1.0		mV/°C
Output Noise Voltage	$f = 10Hz$ to 100kHz	25°C		60		µV
Dropout Voltage	$I_o=1A$	25°C		2.0		V
Bias Current		25°C		4.3	8	mA
Bias Current Change	$V_i=11.5V$ to 27V	0°C to 125°C			1.0	mA
	$I_o=5mA$ to 1A				0.5	
Short-Circuit Output Current		25°C		400		mA
Peak Output Current		25°C		2.2		A

GM7810: $V_i=17V$, $I_o=500mA$, (unless otherwise noted)

CHARACTERISTICS	TEST CONDITIONS *		MIN	TYP	MAX	UNIT
Output Voltage **		25°C	9.6	10	10.4	V
	$I_o=5mA$ to 1A $V_i=12.5V$ to 25V, $P \leq 15W$	0°C to 125°C	9.5	10	10.5	
Input Regulation	$V_i=12.5V$ to 28V	25°C		7	200	mV
	$V_i=14V$ to 20V			2	100	
Ripple Rejection	$V_i=13V$ to 23V, $f = 120Hz$	0°C to 125°C	55	71		dB
Output Regulation	$I_o=5mA$ to 1.5A	25°C		12	200	mV
	$I_o=250mA$ to 750mA			4	100	
Output Resistance	$f = 1kHz$	0°C to 125°C		0.018		
Temperature Coefficient Output Voltage	$I_o=5mA$	0°C to 125°C		-1.0		mV/°C
Output Noise Voltage	$f = 10Hz$ to 100kHz	25°C		70		µV
Dropout Voltage	$I_o=1A$	25°C		2.0		V
Bias Current		25°C		4.3	8	mA
Bias Current Change	$V_i=12.5V$ to 28V	0°C to 125°C			1.0	mA
	$I_o=5mA$ to 1A				0.5	
Short-Circuit Output Current		25°C		400		mA
Peak Output Current		25°C		2.2		A

*Pulse testing techniques are used to maintain the junction temperature as close to the ambient temperature as possible. Thermal effects must be taken into account.

** The specification applies only for DC power dissipation permitted by absolute maximum ratings

◆ ELECTRICAL CHARACTERISTICS at specified Junction Temperature

GM7812: $V_I=19V$, $I_O=500mA$, (unless otherwise noted)

CHARACTERISTICS	TEST CONDITIONS *	MIN	TYP	MAX	UNIT	
Output Voltage **		25°C	11.5	12	12.5	V
	$I_O=5mA$ to 1A $V_I=14.5V$ to 27V, $P \leq 15W$	0°C to 125°C	11.4	12	12.6	
Input Regulation	$V_I=14.5V$ to 30V	25°C		10	240	mV
	$V_I=16V$ to 22V			3	120	
Ripple Rejection	$V_I=15V$ to 25V, $f = 120Hz$	0°C to 125°C	55	71		dB
Output Regulation	$I_O=5mA$ to 1.5A	25°C		12	240	mV
	$I_O=250mA$ to 750mA			4	120	
Output Resistance	$f = 1kHz$	0°C to 125°C		0.018		
Temperature Coefficient Output Voltage	$I_O=5mA$	0°C to 125°C		-1.0		mV/°C
Output Noise Voltage	$f = 10Hz$ to 100kHz	25°C		75		µV
Dropout Voltage	$I_O=1A$	25°C		2.0		V
Bias Current		25°C		4.3	8	mA
Bias Current Change	$V_I=14.5V$ to 30V	0°C to 125°C			1.0	mA
	$I_O=5mA$ to 1A				0.5	
Short-Circuit Output Current		25°C		350		mA
Peak Output Current		25°C		2.2		A

GM7815: $V_I=23V$, $I_O=500mA$, (unless otherwise noted)

CHARACTERISTICS	TEST CONDITIONS *	MIN	TYP	MAX	UNIT	
Output Voltage **		25°C	14.4	15	15.6	V
	$I_O=5mA$ to 1A $V_I=17.5V$ to 30V, $P \leq 15W$	0°C to 125°C	14.25	15	15.75	
Input Regulation	$V_I=17.5V$ to 30V	25°C		12	300	mV
	$V_I=20V$ to 26V			3	150	
Ripple Rejection	$V_I=18.5V$ to 28.5V, $f = 120Hz$	0°C to 125°C	54	70		dB
Output Regulation	$I_O=5mA$ to 1.5A	25°C		12	300	mV
	$I_O=250mA$ to 750mA			4	150	
Output Resistance	$f = 1kHz$	0°C to 125°C		0.019		
Temperature Coefficient Output Voltage	$I_O=5mA$	0°C to 125°C		-1.0		mV/°C
Output Noise Voltage	$f = 10Hz$ to 100kHz	25°C		90		µV
Dropout Voltage	$I_O=1A$	25°C		2.0		V
Bias Current		25°C		4.3	8	mA
Bias Current Change	$V_I=17.5V$ to 30V	0°C to 125°C			1.0	mA
	$I_O=5mA$ to 1A				0.5	
Short-Circuit Output Current		25°C		230		mA
Peak Output Current		25°C		2.1		A

*Pulse testing techniques are used to maintain the junction temperature as close to the ambient temperature as possible. Thermal effects must be taken into account.

** The specification applies only for DC power dissipation permitted by absolute maximum ratings

◆ ELECTRICAL CHARACTERISTICS at specified Junction Temperature

GM7818: $V_I=27V$, $I_O=500mA$, (unless otherwise noted)

CHARACTERISTICS	TEST CONDITIONS *		MIN	TYP	MAX	UNIT
Output Voltage **		25°C	17.3	18	18.7	V
	$I_O=5mA$ to 1A $V_I=21V$ to 33V, $P \leq 15W$	0°C to 125°C	17.1	18	18.9	
Input Regulation	$V_I=21V$ to 33V	25°C		15	360	mV
	$V_I=24V$ to 30V			5	180	
Ripple Rejection	$V_I=22V$ to 32V, $f = 120Hz$	0°C to 125°C	53	69		dB
Output Regulation	$I_O=5mA$ to 1.5A	25°C		12	360	mV
	$I_O=250mA$ to 750mA			4	180	
Output Resistance	$f = 1kHz$	0°C to 125°C		0.022		
Temperature Coefficient Output Voltage	$I_O=5mA$	0°C to 125°C		-1.0		mV/°C
Output Noise Voltage	$f = 10Hz$ to 100kHz	25°C		110		µV
Dropout Voltage	$I_O=1A$	25°C		2.0		V
Bias Current		25°C		4.5	8	mA
Bias Current Change	$V_I=21V$ to 33V	0°C to 125°C			1.0	mA
	$I_O=5mA$ to 1A				0.5	
Short-Circuit Output Current		25°C		200		mA
Peak Output Current		25°C		2.1		A

GM7820: $V_I=29V$, $I_O=500mA$, (unless otherwise noted)

CHARACTERISTICS	TEST CONDITIONS *		MIN	TYP	MAX	UNIT
Output Voltage **		25°C	19.2	20	20.8	V
	$I_O=5mA$ to 1A $V_I=23V$ to 35V, $P \leq 15W$	0°C to 125°C	19	20	21	
Input Regulation	$V_I=23V$ to 35V	25°C		18	400	mV
	$V_I=26V$ to 32V			7	200	
Ripple Rejection	$V_I=24V$ to 34V, $f = 120Hz$	0°C to 125°C	51	66		dB
Output Regulation	$I_O=5mA$ to 1.5A	25°C		15	400	mV
	$I_O=250mA$ to 750mA			7	200	
Output Resistance	$f = 1kHz$	0°C to 125°C		0.027		
Temperature Coefficient Output Voltage	$I_O=5mA$	0°C to 125°C		-1.3		mV/°C
Output Noise Voltage	$f = 10Hz$ to 100kHz	25°C		150		µV
Dropout Voltage	$I_O=1A$	25°C		2.0		V
Bias Current		25°C		4.5	8	mA
Bias Current Change	$V_I=23V$ to 35V	0°C to 125°C			1.0	mA
	$I_O=5mA$ to 1A				0.5	
Short-Circuit Output Current		25°C		180		mA
Peak Output Current		25°C		2.1		A

*Pulse testing techniques are used to maintain the junction temperature as close to the ambient temperature as possible. Thermal effects must be taken into account.

** The specification applies only for DC power dissipation permitted by absolute maximum ratings

◆ ELECTRICAL CHARACTERISTICS at specified Junction Temperature

GM7824: $V_i=33V$, $I_o=500mA$, (unless otherwise noted)

CHARACTERISTICS	TEST CONDITIONS *	MIN	TYP	MAX	UNIT
Output Voltage **	$I_o=5mA$ to 1A $V_i=27V$ to 38V, $P \leq 15W$	23	24	25	V
	$25^\circ C$	22.8	24	25.2	
Input Regulation	$V_i=27V$ to 38V	$0^\circ C$ to $125^\circ C$	18	480	mV
	$V_i=30V$ to 36V		6	240	
Ripple Rejection	$V_i=28V$ to 32V, $f = 120Hz$	$0^\circ C$ to $125^\circ C$	50	66	dB
Output Regulation	$I_o=5mA$ to 1.5A	$25^\circ C$	12	480	mV
	$I_o=250mA$ to 750mA		4	240	
Output Resistance	$f = 1kHz$	$0^\circ C$ to $125^\circ C$	0.028		
Temperature Coefficient Output Voltage	$I_o = 5mA$	$0^\circ C$ to $125^\circ C$	-1.5		mV/ $^\circ C$
Output Noise Voltage	$f = 10Hz$ to 100kHz	$25^\circ C$	170		μV
Dropout Voltage	$I_o = 1A$	$25^\circ C$	2.0		V
Bias Current		$25^\circ C$	4.6	8	mA
Bias Current Change	$V_i = 27V$ to 38V	$0^\circ C$ to $125^\circ C$		1.0	mA
	$I_o=5mA$ to 1A			0.5	
Short-Circuit Output Current		$25^\circ C$	150		mA
Peak Output Current		$25^\circ C$	2.1		A

GM7827: $V_i=36V$, $I_o=500mA$, (unless otherwise noted)

CHARACTERISTICS	TEST CONDITIONS *	MIN	TYP	MAX	UNIT
Output Voltage **	$I_o=5mA$ to 1A $V_i=30V$ to 40V, $P \leq 15W$	25.9	27	28.1	V
	$25^\circ C$	25.7	27	28.3	
Input Regulation	$V_i=30V$ to 40V	$0^\circ C$ to $125^\circ C$	25	540	mV
	$V_i=33V$ to 39V		10	270	
Ripple Rejection	$V_i=30V$ to 40V, $f = 120Hz$	$0^\circ C$ to $125^\circ C$	50	64	dB
Output Regulation	$I_o=5mA$ to 1.5A	$25^\circ C$	20	540	mV
	$I_o=250mA$ to 750mA		9	270	
Output Resistance	$f = 1kHz$	$0^\circ C$ to $125^\circ C$	0.030		
Temperature Coefficient Output Voltage	$I_o = 5mA$	$0^\circ C$ to $125^\circ C$	-1.6		mV/ $^\circ C$
Output Noise Voltage	$f = 10Hz$ to 100kHz	$25^\circ C$	200		μV
Dropout Voltage	$I_o = 1A$	$25^\circ C$	2.0		V
Bias Current		$25^\circ C$	4.8	8	mA
Bias Current Change	$V_i = 30V$ to 40V	$0^\circ C$ to $125^\circ C$		1.0	mA
	$I_o=5mA$ to 1A			0.5	
Short-Circuit Output Current		$25^\circ C$	120		mA
Peak Output Current		$25^\circ C$	2.1		A

*Pulse testing techniques are used to maintain the junction temperature as close to the ambient temperature as possible. Thermal effects must be taken into account.

** The specification applies only for DC power dissipation permitted by absolute maximum ratings

◆ TO-263-2 PACKAGE OUTLINE DIMENSIONS

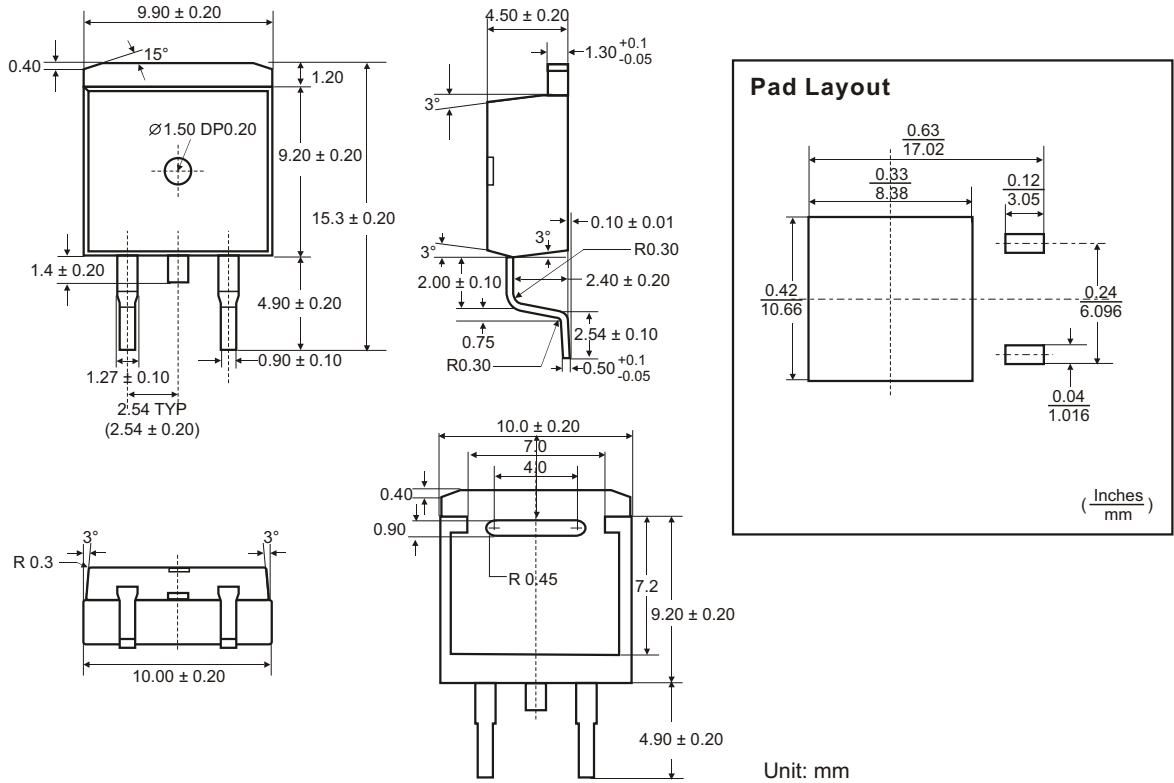

◆ TO-220 PACKAGE OUTLINE DIMENSIONS

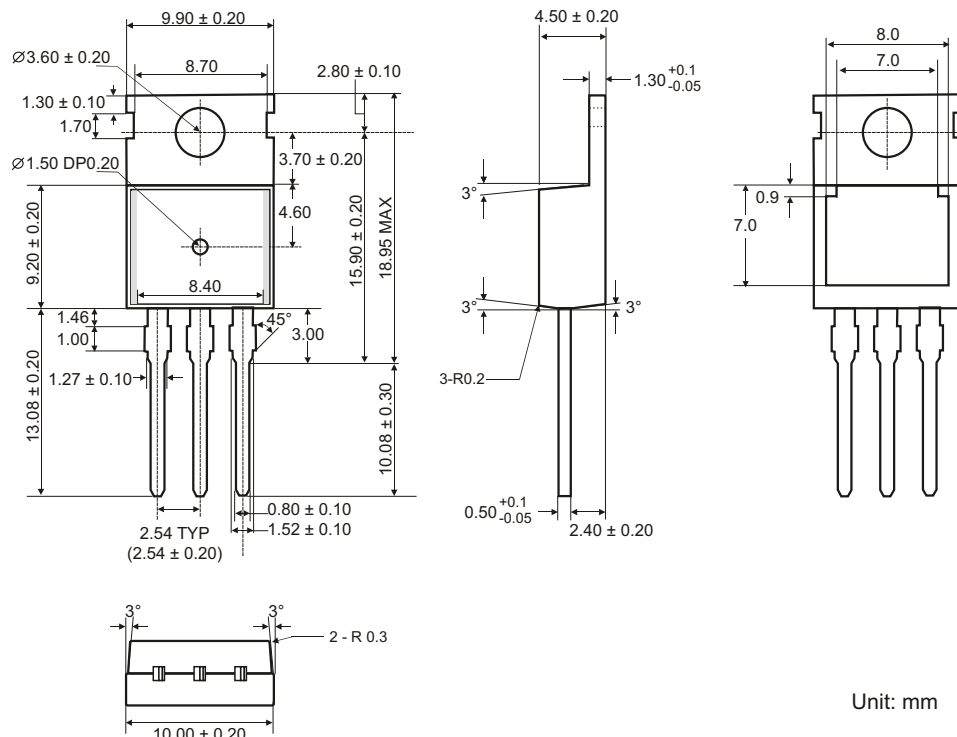

◆ TO-252 PACKAGE OUTLINE DIMENSIONS

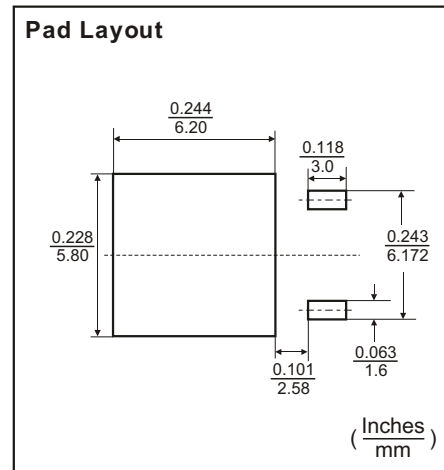
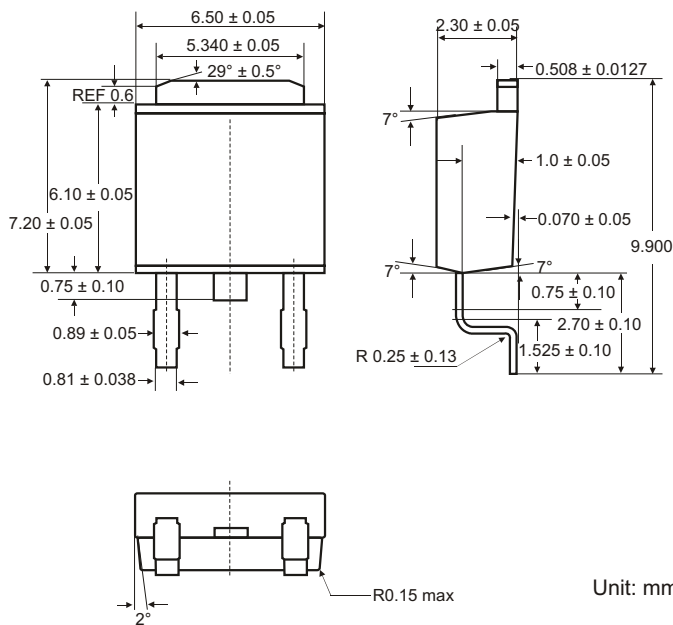

◆ ORDERING NUMBER

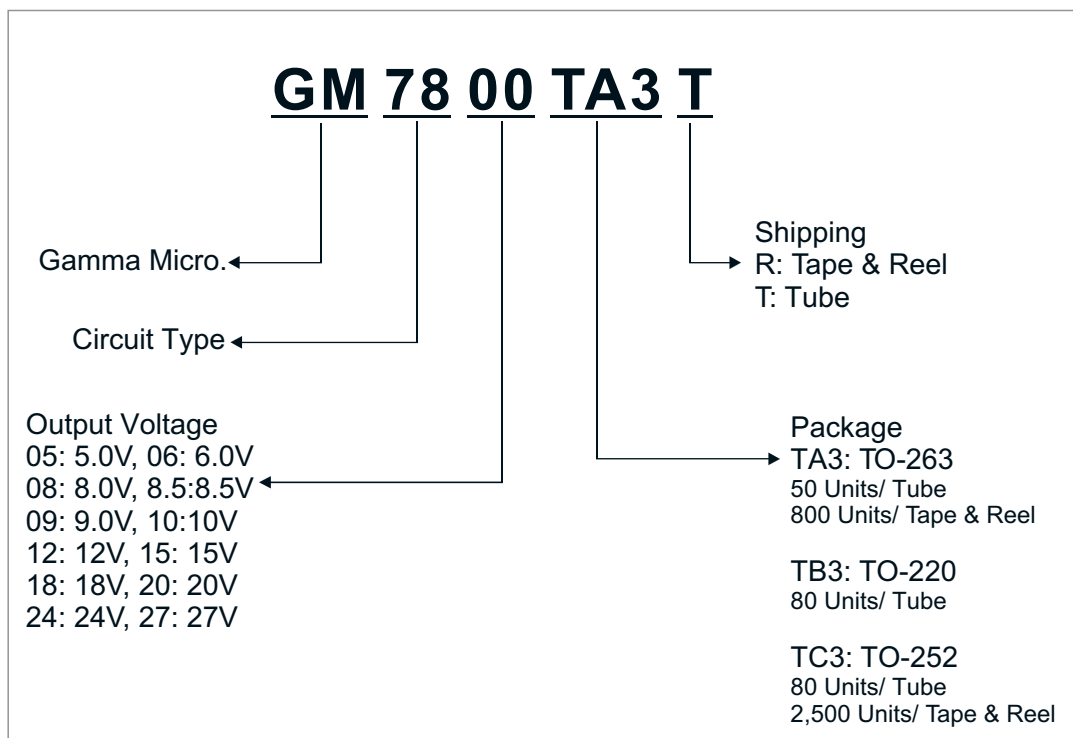





Power Management

GM7800 SERIES

POSITIVE VOLTAGE REGULATORS

GAMMA Micro, , and  are registered trademarks of GAMMA MICROELECTRONICS INC. GAMMA reserves the right to make changes without further notice to any products herein. Information provided herein is alleged to be exact and consistent and this publication surpasses and replaces all information previously supplied.

GAMMA makes no warranty the suitability of its products for any particular purpose, nor does GAMMA assume any liability arising out of the application or use of any product or circuit, and specifically disclaims any and all liability including without limitation special, consequential or incidental damages.

GAMMA products are not authorized for using as critical components in life support devices or systems without prior written approval from GAMMA MICROELECTRONICS INC.