

Features

- Active Mixer with Conversion Gain
- No External LO Driver Necessary
- Low LO Drive Level Required
- RF and LO Ports May Be Driven Single-ended
- Single 5-V Supply Voltage
- High LO-RF Isolation
- Broadband Resistive 50-Ω Impedances on All Three Ports

Applications

- Infrastructure Digital Communication Systems
- 1700 MHz to 2300 MHz Receivers for CDMA/PCS/DCS/UMTS Base Stations

Electrostatic sensitive device.
Observe precautions for handling.



Description

The T0781 is a high linearity active mixer which is manufactured using Atmel's advanced Silicon-Germanium technology. This mixer features a frequency range of 1700 MHz to 2300 MHz. It operates from a single 5-V supply and provides 12 dB of conversion gain while requiring only 0 dBm input to the integrated LO driver. An IF amplifier is also included.

The T0781 incorporates internal matching on each RF, IF and LO ports to enhance ease of use and to reduce the external components required. The RF and LO inputs can be driven differentially or single-ended.

Figure 1. Block Diagram

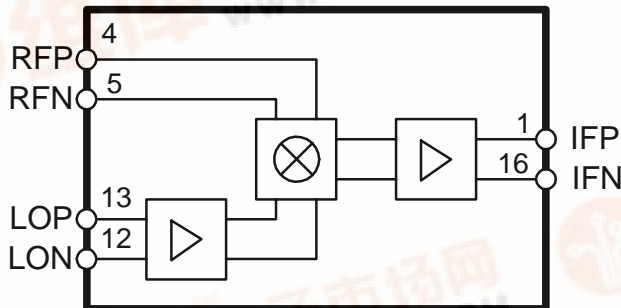

**1700 - 2300 MHz
High Linearity
SiGe Active
Receiver Mixer**

T0781

Preliminary



Pin Configuration

Figure 2. Pinning SSOP16

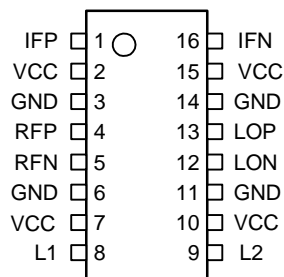

Pin Description

Pin	Symbol	Function
1	IFP	IF positive output
2	VCC	5-V power supply
3	GND	Ground
4	RFP	RF positive input
5	RFN	RF negative input
6	GND	Ground
7	VCC	5-V power supply
8	L1	External inductor terminal
9	L2	External inductor terminal
10	VCC	5-V power supply
11	GND	Ground
12	LON	Local oscillator, negative input
13	LOP	Local oscillator, positive input
14	GND	Ground
15	VCC	5-V power supply
16	IFN	IF negative output

Absolute Maximum Ratings ⁽¹⁾

All voltages are referred to GND.

Parameters	Symbol	Value	Unit
Supply voltage	V _{CC}	5.5	V
LO input	LOP, LON	10	dBm
IF input	RFP, RFN	15	V
Operating temperature	T _{OP}	-40 to +85	°C
Storage temperature	T _{stg}	-65 to +150	°C

Notes: 1. The device may not survive all maximum values applied simultaneously.

Thermal Resistance

Parameters	Symbol	Value	Unit
Junction ambient	R _{thJA}	TBD	K/W
Junction case	R _{thJC}	46	°C/W

Electrical Characteristics

Test Conditions: V_{CC} = 5 V, T_{amb} = 25°C, RF input: -40 dB at 1880 MHz, LO input: 0 dBm at 1680 MHz

No.	Parameters	Test Conditions	Pin	Symbol	1700 to 2000 MHz Operation			2000 to 2300 MHz Operation			Unit	Type*
					Min.	Typ.	Max.	Min.	Typ.	Max.		
1	AC Performance											
1.1	RF frequency range	For RF = 2000 to 2300 MHz operation, single-ended RF + LO drive is recommended	4, 5	f _{RF}	1700		2000	2000		2300	MHz	B, C
1.11	LO frequency range			f _{LO}	1400		2000	1700		2300	MHz	B, C
1.2	IF frequency range		1, 16	F _{IF}	30	200	300	30	200	300	MHz	B, C
1.3	Input IP3	RF1 = RF2 = -15 dBm/tone, 1 MHz spacing	4, 5	IIP3	12	15		12	15		dBm	D
1.4	Input P1dB		4, 5	P1dB	1	2		3	5		dBm	D
1.5	Conversion gain		1, 16	G	9	12		6	9		dB	A

*) Type means: A = 100% tested, B = 100% correlation tested, C = Characterized on samples, D = Design parameter

Note: 1. The return losses shown were measured with the T0781 mounted on Atmel's FR4 evaluation boards using standard matching practices as indicated on the respective application schematic (see Figure 23 and Figure 24). Users following the RF, LO and IF matching guidelines will achieve similar performance.



Electrical Characteristics (Continued)

Test Conditions: $V_{CC} = 5\text{ V}$, $T_{amb} = 25^{\circ}\text{C}$, RF input: -40 dB at 1880 MHz, LO input: 0 dBm at 1680 MHz

No.	Parameters	Test Conditions	Pin	Symbol	1700 to 2000 MHz Operation			2000 to 2300 MHz Operation			Unit	Type*
					Min.	Typ.	Max.	Min.	Typ.	Max.		
1.6	SSB noise figure		1, 16	NF_{SSB}		14	15		16	19	dB	D
1.7	RF return loss	Matched to $50\ \Omega$ ⁽¹⁾	4, 5	RL_{RF}		20			20		dB	D
1.8	LO return loss	Matched to $50\ \Omega$ ⁽¹⁾	12, 13	RL_{LO}		20			20		dB	D
1.9	IF return loss	Matched to $50\ \Omega$ ⁽¹⁾	1, 16	RL_{IF}		20			20		dB	D
1.10	LO drive	Matched to $50\ \Omega$	12, 13	P_{LO}	-3	0	+3	-3	0	+3	dBm	D
2	Isolation Performance											
2.1	Leakage (LO-RF)		12, 13	A_{LO-RF}		-60	-40		-30	-20	dBm	D
2.2	Leakage (LO-IF)		12, 13	A_{LO-IF}		-30	-20		-30	-20	dBm	D
2.3	Leakage (RF-IF)					-53	-40		-35	-25	dBm	D
3	Miscellaneous											
3.1	Supply voltage		2, 7, 10, 15	V_{CC}	4.75	5.0	5.25	4.75	5.0	5.25	V	A
3.2	Supply current		2, 7, 10, 15	I_{CC}		160	180		160	180	mA	A

*) Type means: A = 100% tested, B = 100% correlation tested, C = Characterized on samples, D = Design parameter

Note: 1. The return losses shown were measured with the T0781 mounted on Atmel's FR4 evaluation boards using standard matching practices as indicated on the respective application schematic (see Figure 23 and Figure 24). Users following the RF, LO and IF matching guidelines will achieve similar performance.

1700 MHz to 2000 MHz: Typical Device Performance

Figure 3. Conversion Gain Versus Temperature, $P_{LO} = 0$ dBm

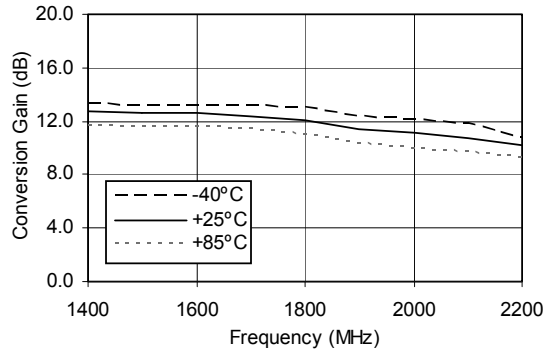

Figure 4. Conversion Gain Versus LO Drive, $T_{amb} = 25^\circ\text{C}$

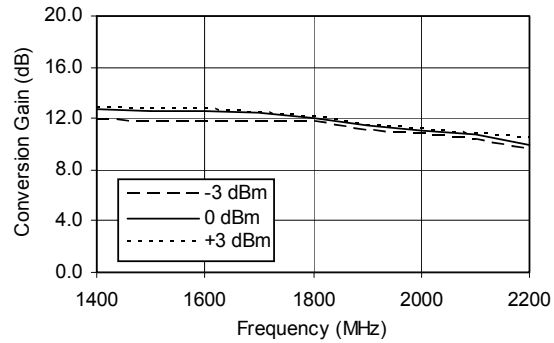

Figure 5. Leakages, $P_{LO} = 0$ dBm at Pins, $P_{RF} = -20$ dBm at Pins, $T_{amb} = 25^\circ\text{C}$

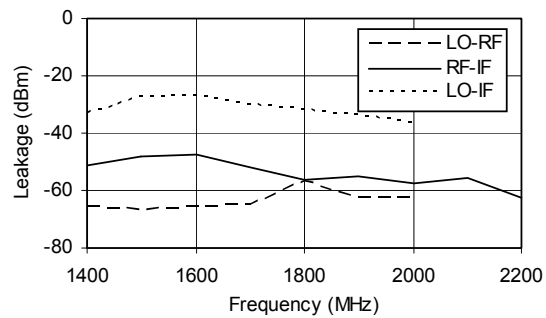

Figure 6. Input IP3 Versus Temperature $P_{LO} = 0$ dBm

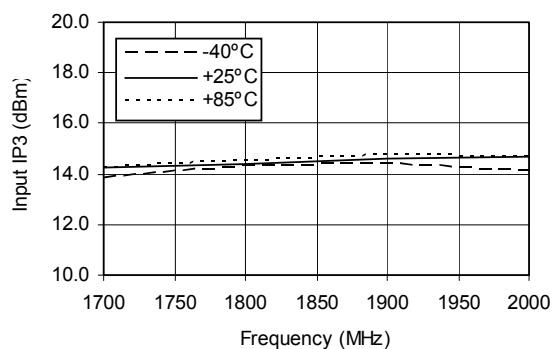

Figure 7. Input IP3 Versus LO Drive, $T_{amb} = 25^\circ\text{C}$

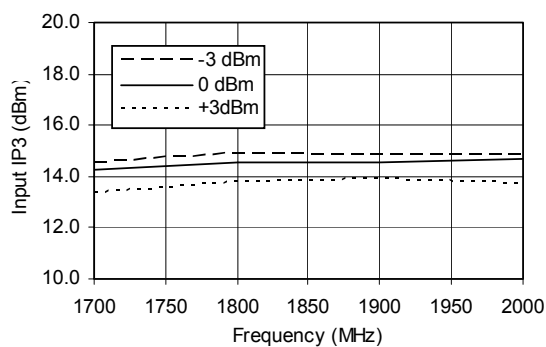

Figure 8. Noise Figure Versus Temperature, $P_{LO} = 0$ dBm

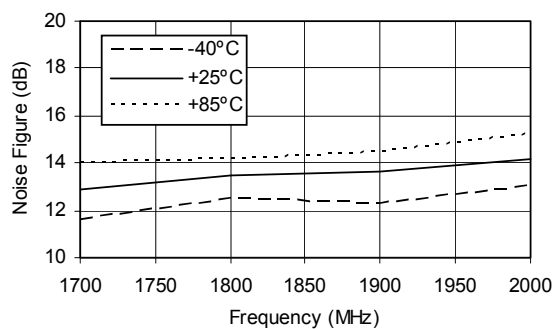

Figure 9. RF & LO Return Loss, $T_{amb} = 25^{\circ}\text{C}$

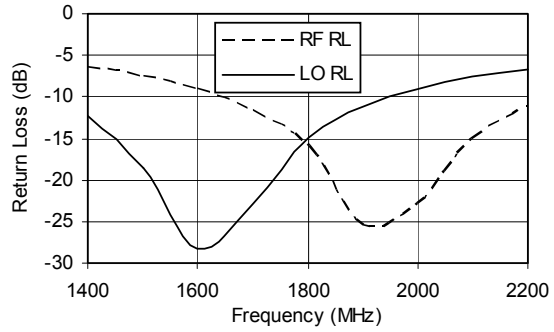

Figure 10. IF Return Loss, $T_{amb} = 25^{\circ}\text{C}$

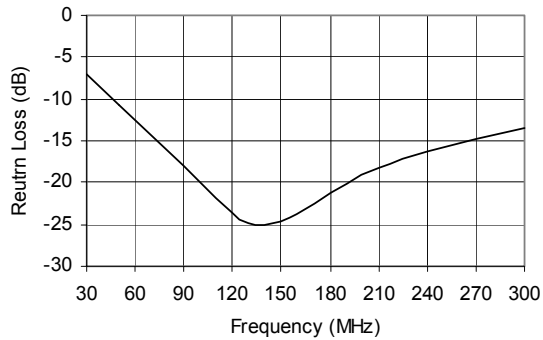

Figure 11. Input P1dB Versus Temperature, $P_{LO} = 0 \text{ dBm}$

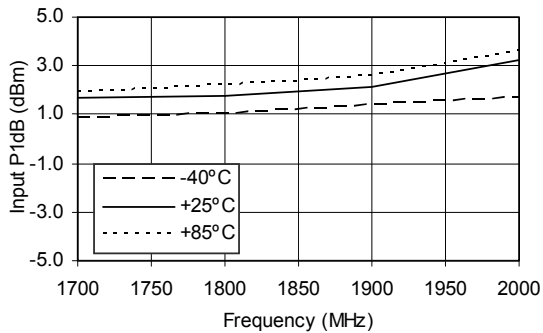
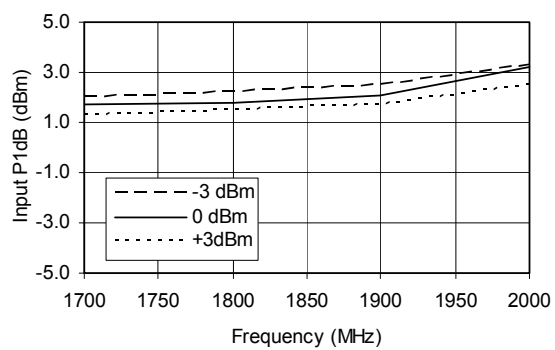



Figure 12. Input P1dB Versus LO Drive, $T_{amb} = 25^{\circ}\text{C}$



2200 MHz to 2300 MHz: Typical Device Performance, Single-ended Drive

Figure 13. Conversion Gain Versus Temperature, $P_{LO} = 0$ dBm

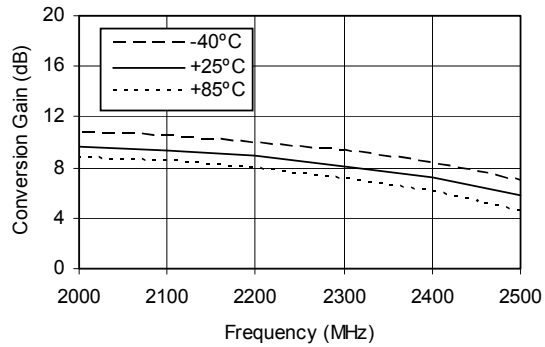

Figure 14. Conversion Gain Versus LO Drive, $T_{amb} = 25^\circ\text{C}$

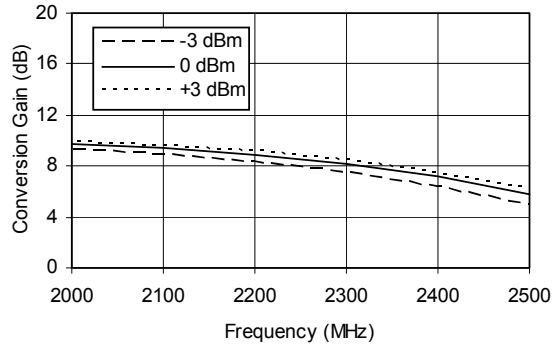

Figure 15. Leakages, $P_{LO} = 0$ dBm at Pins, $P_{RF} = -20$ dBm at Pins, $T_{amb} = 25^\circ\text{C}$

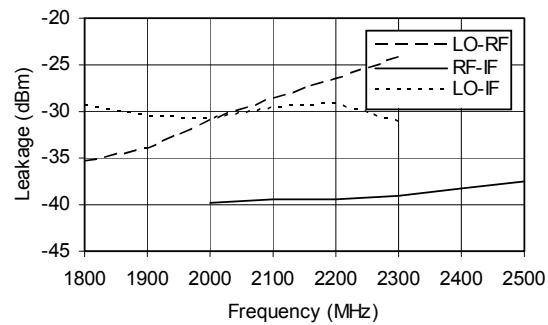



Figure 16. Input IP3 Versus Temperature $P_{LO} = 0$ dBm

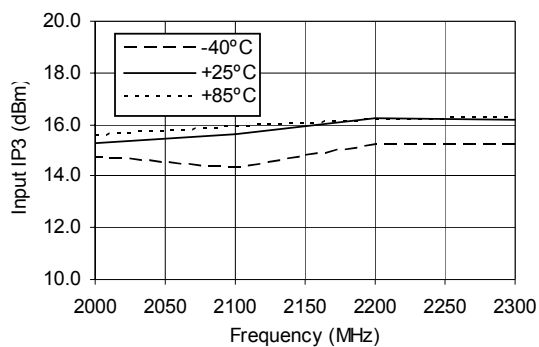

Figure 17. Input IP3 Versus LO Drive, $T_{amb} = 25^\circ\text{C}$

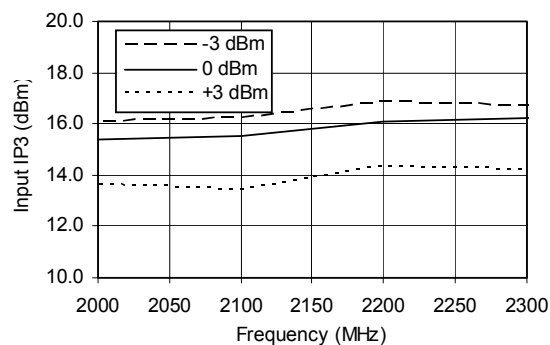

Figure 18. Input P1dB Versus Temperature, $T_{amb} = 25^\circ\text{C}$

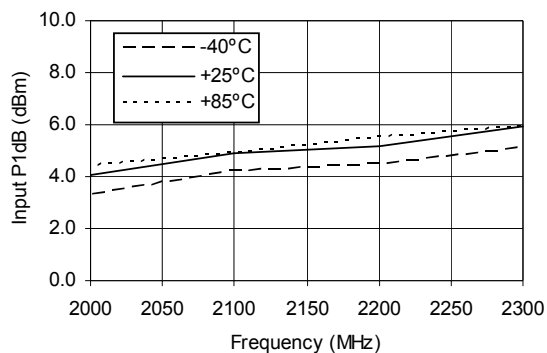

Figure 19. RF & LO Return Loss, $V_{CC} = 5\text{ V}$, $T_{amb} = 25^\circ\text{C}$

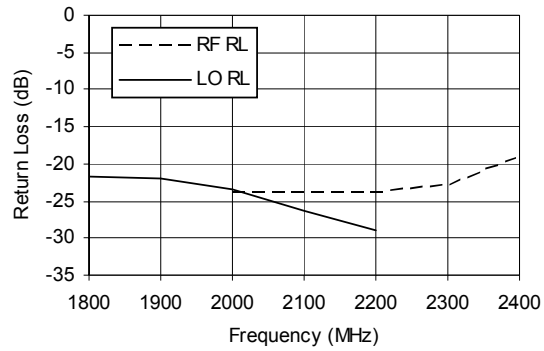

Figure 20. IF Return Loss, $T_{amb} = 25^\circ\text{C}$

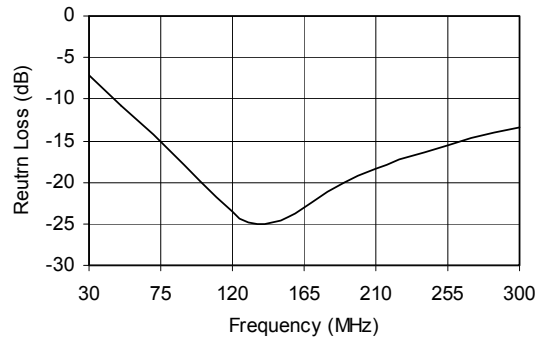

Figure 21. Input P1dB Versus Temperature, $P_{LO} = 0\text{ dBm}$

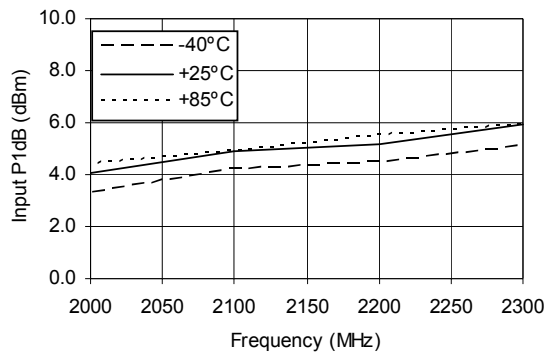

Figure 22. Input P1dB Versus LO Drive, $T_{amb} = 25^{\circ}\text{C}$

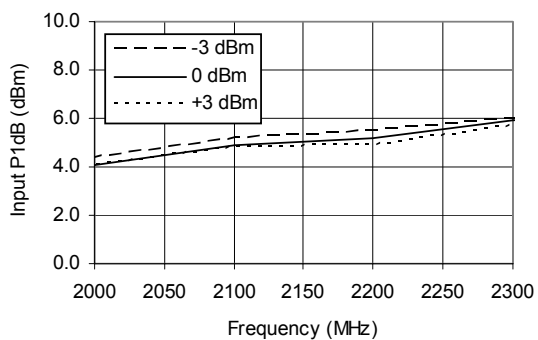
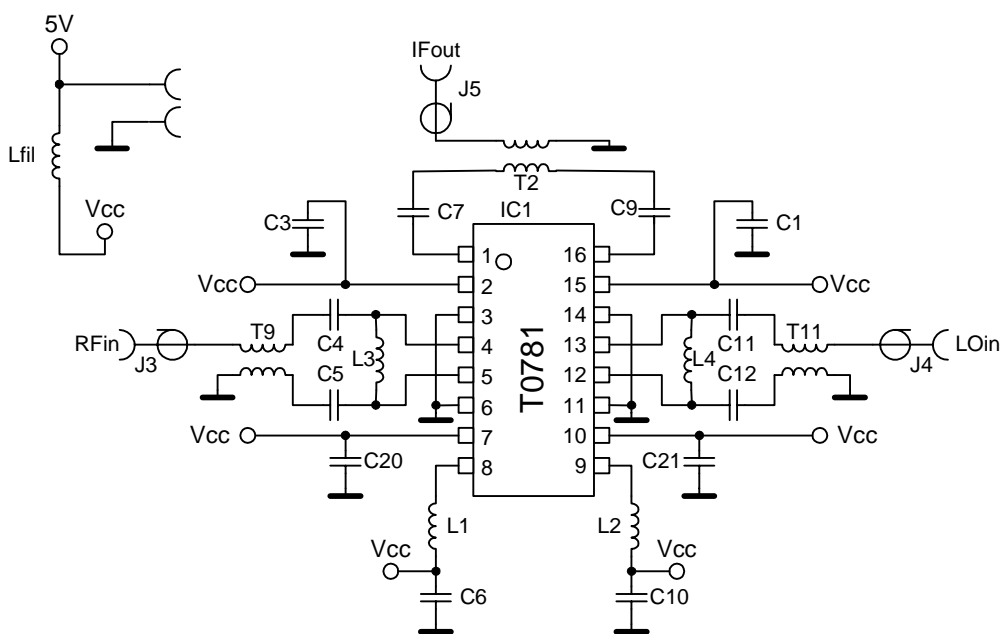

Figure 23. 1700 MHz to 2000 MHz Application Schematic (Differential Drive)



Bill of Materials (for 1700 MHz to 2000 MHz Evaluation Board)

Component Designator	Value	Vendor	Part Number	Description
IC1		Atmel	T0781	SiGe receiver mixer
J3, J4, J5		Johnson Components	142-0701-851	SMA connector, end launch with tab, for 0.062 inch board
T9, T11	1:1	Panasonic	EHF-FD1619	RF transformer
T2	1:1	Mini-Circuits	TC1-1	IF transformer
Lfil	1 μ H	Würth Elektronik	74476401	Inductor, 1210 footprint, minimum 200 mA rating
L1, L2	see Table 1	TOKO	LL1608-FSR10J	Inductor, 0603 footprint, high Q series
L3	nc			
L4	nc			
C1, C3, C20, C21	6.8 pF			Capacitor, 0603 footprint
C6, C10	100 pF			Capacitor, 0603 footprint
C7, C9	120 pF			Capacitor, 0603 footprint
C4, C5	2.2 pF			Capacitor, 0603 footprint
C11, C12	3.3 pF			Capacitor, 0603 footprint

The T0781 utilizes an IF tank circuit to maximize performance across the entire IF bandwidth. The off-chip inductors L1 and L2 resonate with an on-chip capacitor (4 pF) to provide IF tunability. Therefore, L1 and L2 must be selected such that the resonance occurs at the desired IF.

The following table provides the inductor values required on the evaluation board for some common intermediate frequencies. By default, all evaluation boards are shipped with L1 = L2 = 100 nH, resulting in a 200 MHz resonant IF.

Table 1. IF Tank Circuit

IF (MHz) Typical	L1, L2 (nH)	TOKO Part Number
70	680	LL2012-FHR68J
150	150	LL1608-FSR15J
200	100	LL1608-FSR10J
300	39	LL1608-FS39NJ

Figure 24. Demo Test Board (Fully Assembled PCB)

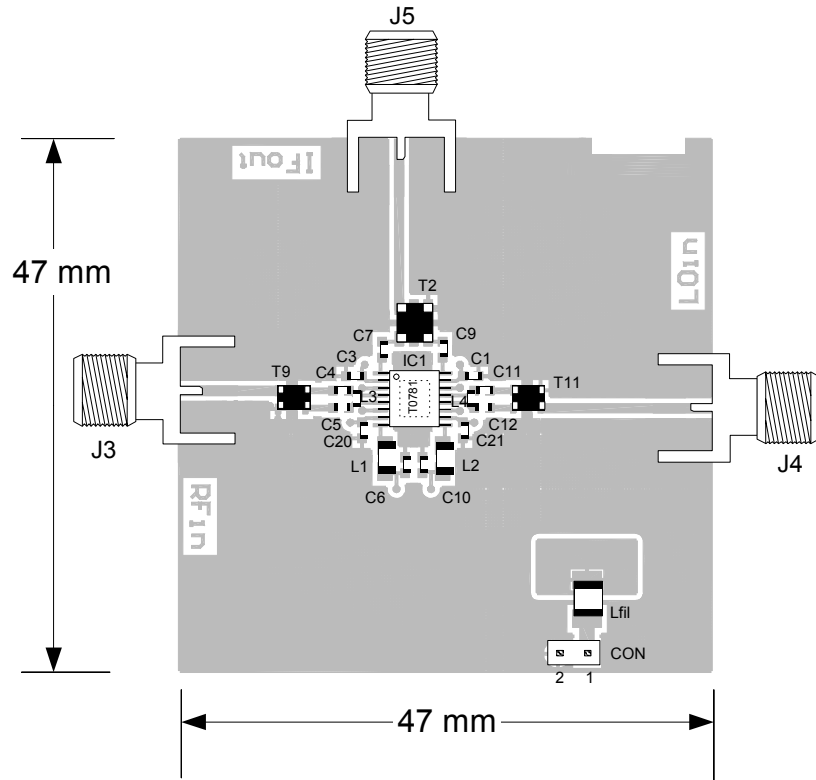
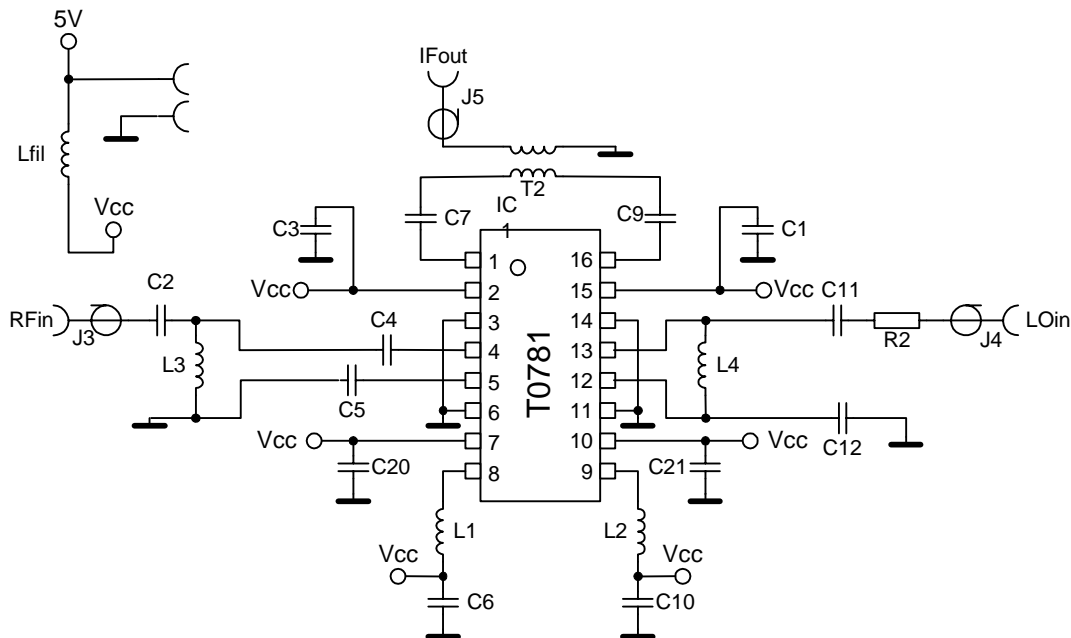

Figure 25. 2000 MHz to 2300 MHz Application Schematic (Single-ended Drive)



Bill of Materials for (2000 MHz to 2300 MHz Evaluation Board)

Component Designator	Value	Vendor	Part Number	Description
IC1		Atmel	T0781	SiGe receiver mixer
J3, J4, J5		Johnson Components	142-0701-851	SMA connector, end launch with tab, for 0.062 inch board
T2	1:1	Mini-Circuits	TC1-1	IF transformer
Lfil	1 μ H	Würth Elektronik	74476401	Inductor, 1210 footprint, minimum 200 mA rating
L1, L2	see Table 1	TOKO	LL1608-FSR10J	Inductor, 0603 footprint, high Q series
L3	2.2 nH			
L4	3.3 nH	TOKO	LL1608-FSR8NJ	Inductor, 0603 footprint, high Q series
C1, C3, C20, C21	6.8 pF			Capacitor, 0603 footprint
C2	2.7 pF			
C4	18 pF			
C6, C10	100 pF			Capacitor, 0603 footprint
C7, C9	120 pF			Capacitor, 0603 footprint
C5	2.2 pF			Capacitor, 0603 footprint
C11	3.3 pF			Capacitor, 0603 footprint
C12	2.7 pF			Capacitor, 0603 footprint
R1, R2	0 μ			Resistor, 0603 footprint

Figure 26. Demo Test Board (Fully Assembled PCB)

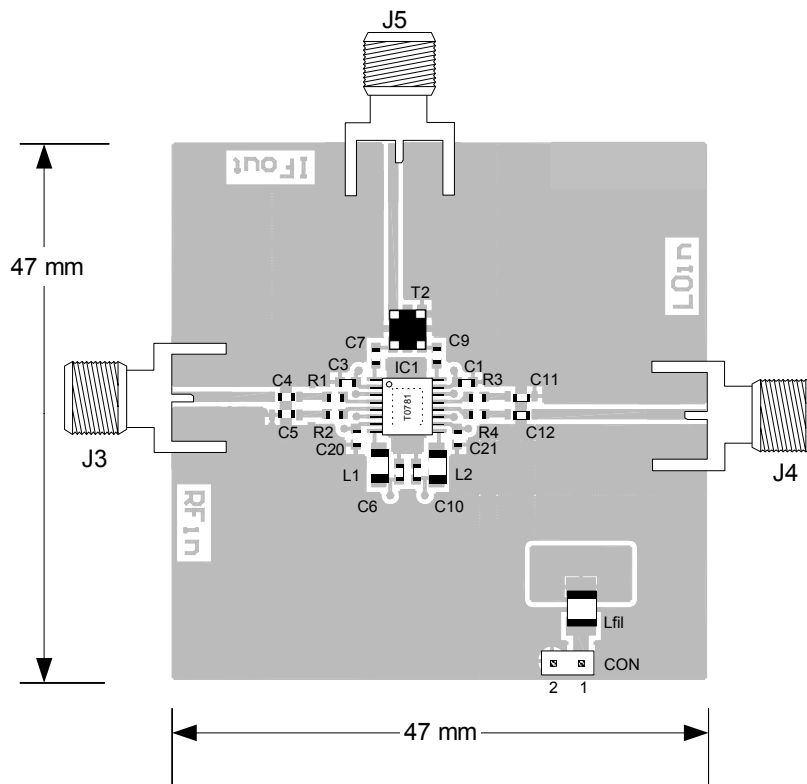
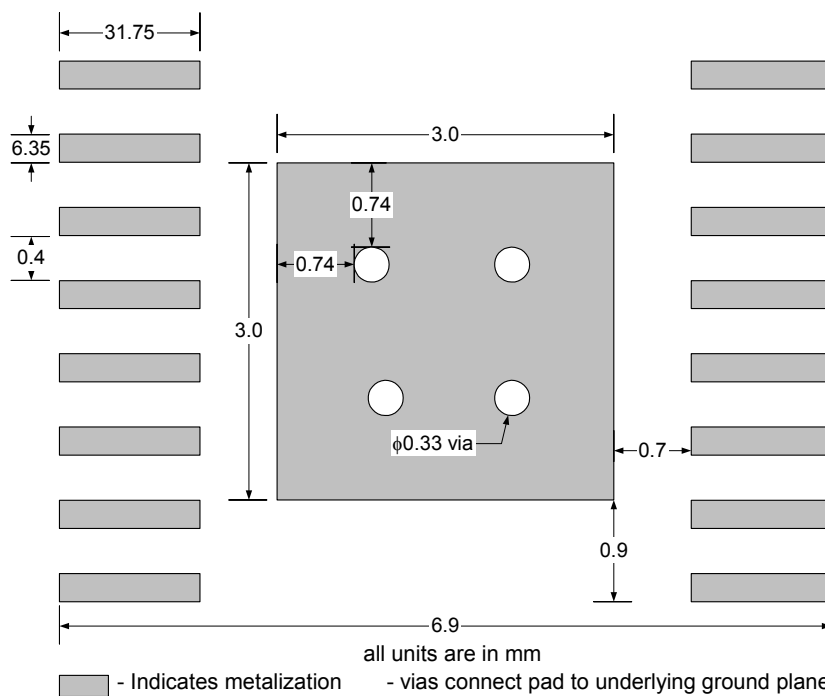

Figure 27. Recommended Package Footprint

In order to avoid soldering problems, plugging of the ground vias under the heat slug is recommended!



Remark: Heatslug must be soldered to GND.

Ordering Information

Extended Type Number	Package	Remarks
T0781-6C	TSSOP16	-

Package Information

Package: SSOP16
 (acc. JEDEC SMALL OUTLINE No. MO-153)
 Dimensions in mm

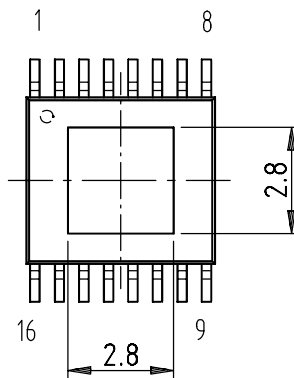

technical drawings
 according to DIN
 specifications

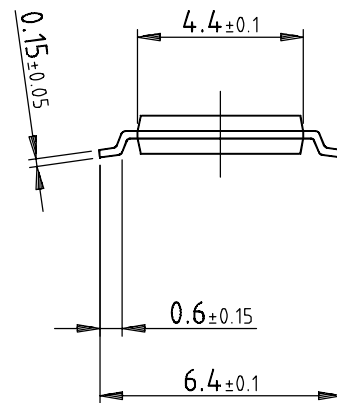
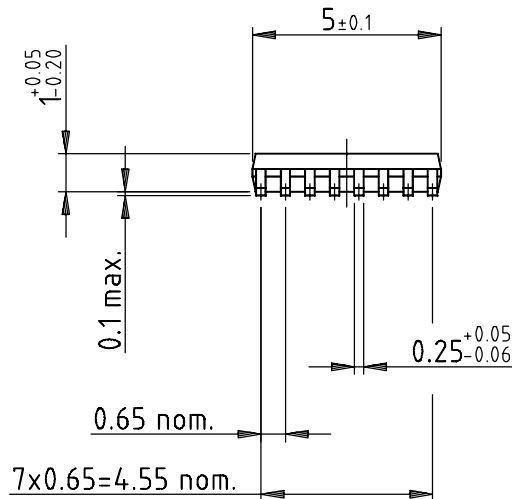

Drawing-No.: 6.543-5079.01-4
 Issue: 1; 10.07.01



Atmel Headquarters

Corporate Headquarters
2325 Orchard Parkway
San Jose, CA 95131
TEL 1(408) 441-0311
FAX 1(408) 487-2600

Europe
Atmel Sarl
Route des Arsenaux 41
Case Postale 80
CH-1705 Fribourg
Switzerland
TEL (41) 26-426-5555
FAX (41) 26-426-5500

Asia
Room 1219
Chinachem Golden Plaza
77 Mody Road Tsimhatsui
East Kowloon
Hong Kong
TEL (852) 2721-9778
FAX (852) 2722-1369

Japan
9F, Tonetsu Shinkawa Bldg.
1-24-8 Shinkawa
Chuo-ku, Tokyo 104-0033
Japan
TEL (81) 3-3523-3551
FAX (81) 3-3523-7581

Atmel Operations

Memory
2325 Orchard Parkway
San Jose, CA 95131
TEL 1(408) 441-0311
FAX 1(408) 436-4314

Microcontrollers
2325 Orchard Parkway
San Jose, CA 95131
TEL 1(408) 441-0311
FAX 1(408) 436-4314

La Chantrerie
BP 70602
44306 Nantes Cedex 3, France
TEL (33) 2-40-18-18-18
FAX (33) 2-40-18-19-60

ASIC/ASSP/Smart Cards
Zone Industrielle
13106 Rousset Cedex, France
TEL (33) 4-42-53-60-00
FAX (33) 4-42-53-60-01

1150 East Cheyenne Mtn. Blvd.
Colorado Springs, CO 80906
TEL 1(719) 576-3300
FAX 1(719) 540-1759

Scottish Enterprise Technology Park
Maxwell Building
East Kilbride G75 0QR, Scotland
TEL (44) 1355-803-000
FAX (44) 1355-242-743

RF/Automotive
Theresienstrasse 2
Postfach 3535
74025 Heilbronn, Germany
TEL (49) 71-31-67-0
FAX (49) 71-31-67-2340

1150 East Cheyenne Mtn. Blvd.
Colorado Springs, CO 80906
TEL 1(719) 576-3300
FAX 1(719) 540-1759

**Biometrics/Imaging/Hi-Rel MPU/
High Speed Converters/RF Datacom**
Avenue de Rochepleine
BP 123
38521 Saint-Egreve Cedex, France
TEL (33) 4-76-58-30-00
FAX (33) 4-76-58-34-80

e-mail
literature@atmel.com

Web Site
<http://www.atmel.com>

© Atmel Corporation 2003.

Atmel Corporation makes no warranty for the use of its products, other than those expressly contained in the Company's standard warranty which is detailed in Atmel's Terms and Conditions located on the Company's web site. The Company assumes no responsibility for any errors which may appear in this document, reserves the right to change devices or specifications detailed herein at any time without notice, and does not make any commitment to update the information contained herein. No licenses to patents or other intellectual property of Atmel are granted by the Company in connection with the sale of Atmel products, expressly or by implication. Atmel's products are not authorized for use as critical components in life support devices or systems.

Atmel® is the registered trademark of Atmel.

Other terms and product names may be the trademarks of others.



Printed on recycled paper.