

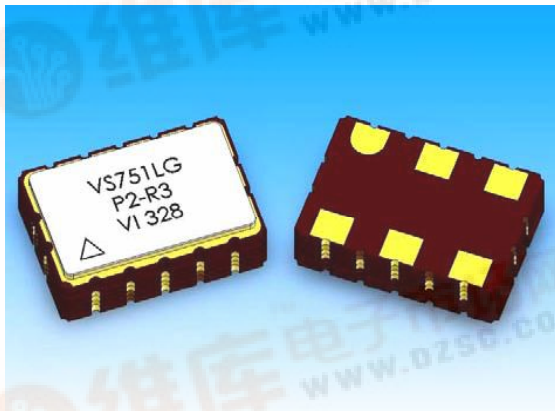

VS-751 Dual Frequency VCSO



Features

- 5 x 7.5 x 2.5 mm Package
- Output Frequencies from 500 MHz to 850 MHz
- 3.3 V Operation
- Low Jitter < 0.25 ps-rms across 50 kHz to 80 MHz
- LV-PECL Configuration with Fast Transition Times
- Complementary Outputs
- Frequency Select
- Patent Pending Technology
- **Pb** Product is free of lead and compliant to EC RoHS Directive

Applications

PLL circuits for Clock Smoothing and Frequency Translation

Description	Standard
• 1-2-4 Gigabit Fibre Channel	INCITS 352-2002
• 10 Gigabit Fibre Channel	INCITS 364-2003
• 10GbE LAN / WAN	IEEE 802.3ae
• OC-192	ITU-T G.709
• SONET / SDH	GR-253-CORE Issue3

Description

The VS-751 is a SAW based voltage controlled oscillator that operates at the fundamental frequencies of the internal SAW filters. These SAW filters are high-Q quartz devices that enable the circuit to achieve low phase jitter performance over a wide operating temperature range. The dual oscillator is housed in a hermetically sealed leadless surface mount package offered on tape and reel. It has a frequency select function that enables either "Frequency 1" or "Frequency 2."

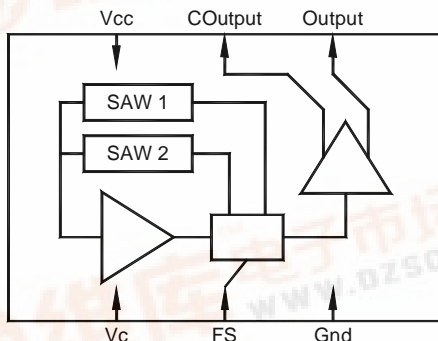

VS-751 Voltage Controlled SAW Oscillator

Electrical Performance						
Parameter	Symbol	Minimum	Typical	Maximum	Units	Notes
Frequency						
Nominal Frequency	f_N		500 - 850		MHz	1,2,3
Absolute Pull Range	APR	± 50			ppm	1,2,3,8
Linearity	L_{in}		± 5		%	2,4,8
Gain Transfer (See Pg 5)	K_V		+405		ppm/V	2,8
Temperature Stability	f_{STAB}		± 100		ppm	1,6
Transition Time			4		μ sec	6
Supply						
Voltage	V_{CC}	2.97	3.3	3.63	V	2,3
Current (No Load)	I_{CC}		55	70	mA	3
Outputs						
Mid Level		$V_{CC}-1.4$	$V_{CC}-1.3$	$V_{CC}-1.2$	V	2,3
Swing		550	650	950	mV-pp	2,3
Current	I_{OUT}			20	mA	6
Rise Time	t_R		250	400	ps	5,6
Fall Time	t_F		250	400	ps	5,6
Symmetry	SYM	45	50	55	%	2,3
Spurious Suppression		50	60		dBc	6
Jitter (See Pg 5)	ϕ_J		0.130	0.250	ps-rms	6,7
Control Voltage						
Input Impedance	Z_C		100		$k\Omega$	6
Modulation Bandwidth	BW		500		kHz	6
Operating Temperature						
	T_{OP}	-40		85	$^{\circ}C$	1,3
Package Size						
		5.0 x 7.5 x 2.5			mm	

1. See Standard Frequencies and Ordering Information (Pg 7).
2. Parameters are tested with production test circuit below (Fig 1).
3. Parameters are tested at ambient temperature with test limits guardbanded for specified operating temperature.
4. Measured as the maximum deviation from the best straight-line fit, per MIL-0-55310.
5. Measured from 20% to 80% of a full output swing (Fig 2).
6. Not tested in production, guaranteed by design, verified at qualification.
7. Integrated across 50 kHz to 80 MHz, per GR-253-CORE Issue3.
8. Tested with $V_c = 0.3V$ to $3.0V$.

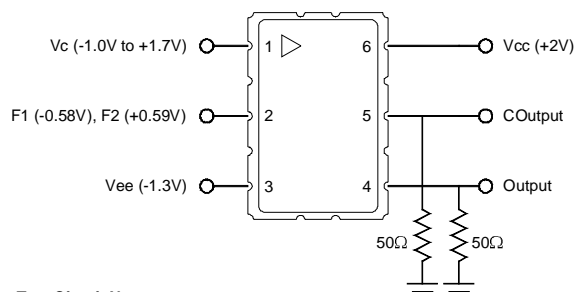

Test Circuit Notes:

- 1) To Permit 50Ω Measurement of Outputs, all DC Inputs are Biased Down 1.3V.
- 2) All Voltage Sources Contain Bypass Capacitors to Minimize Supply Noise.
- 3) 50Ω Terminations are Within Test Equipment.

Figure 1. Test Circuit

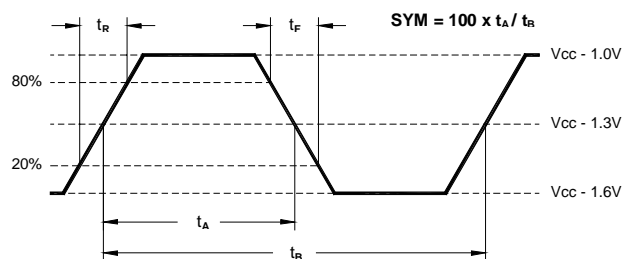
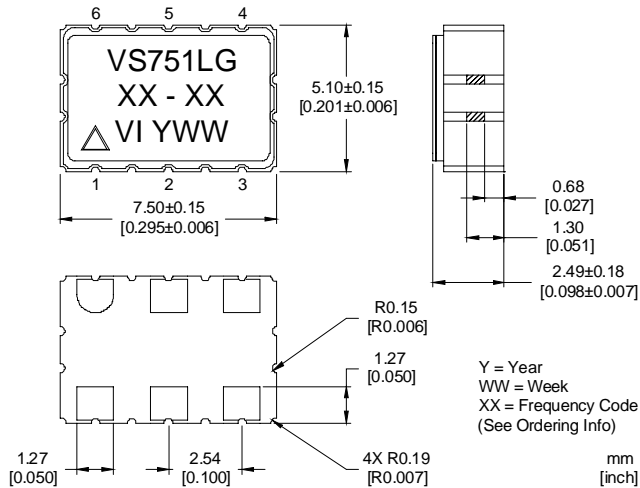

Figure 2. 10K LV-PECL Waveform

VS-751 Voltage Controlled SAW Oscillator

Outline Diagram



Pad Layout

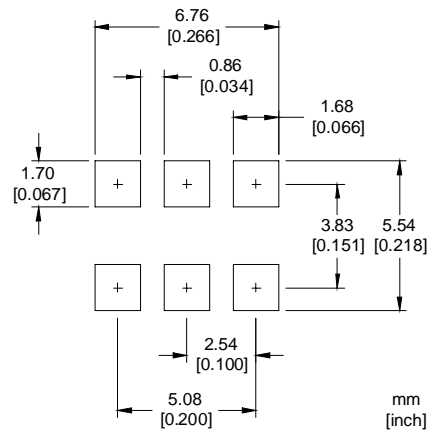

Pin Out

Pin	Symbol	Function
1	V _C	VCSO Control Voltage
2	FS	Frequency Select (See Control Logic)
3	Gnd	Case and Electrical Ground
4	Output	VCSO Output
5	COutput	VCSO Complementary Output
6	V _{CC}	Power Supply Voltage (3.3 V ±10%)

Marking Key

Position 6	Position 7
L = LFF	G = GNN
	H = HNN

Control Logic (LV-CMOS)

FS	Operation
0	F1
1	F2

Tape and Reel (EIA-481-2-A)

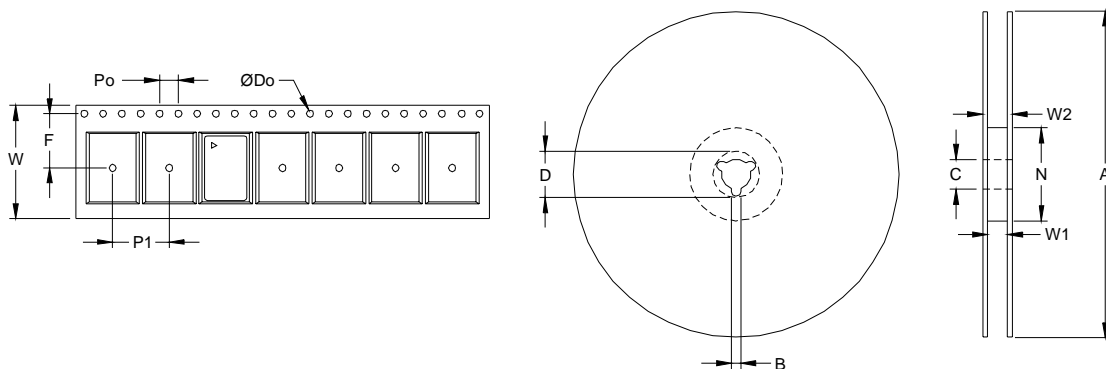

Tape Dimensions (mm)

Reel Dimensions (mm)

Dimension	W	F	Do	Po	P1	A	B	C	D	N	W1	W2	# Per Reel
Tolerance	Typ	Typ	Typ	Typ	Typ	Typ	Min	Typ	Min	Min	Typ	Max	Reel
VS-751	16	7.5	1.5	4	8	178	1.5	13	20.2	50	16.4	22.4	200

VS-751 Voltage Controlled SAW Oscillator

Absolute Maximum Ratings

Parameter	Symbol	Ratings	Unit
Power Supply	V_{CC}	0 to 6	V
Input Current	I_{IN}	100	mA
Output Current	I_{OUT}	25	mA
Voltage Control Range	V_C	0 to V_{CC}	V
Storage Temperature	T_{STR}	-55 to 125	°C
Soldering Temperature / Duration	T_{PEAK} / t_p	260 / 40	°C / sec

Stresses in excess of the absolute maximum ratings can permanently damage the device. Also, exposure to these absolute maximum ratings for extended periods may adversely affect device reliability. Functional operation is not implied at these or any other conditions in excess of those represented in the operational sections of this datasheet. Permanent damage is also possible if any device input (V_C or FS) draws greater than 100mA.

Suggested Output Load Configurations

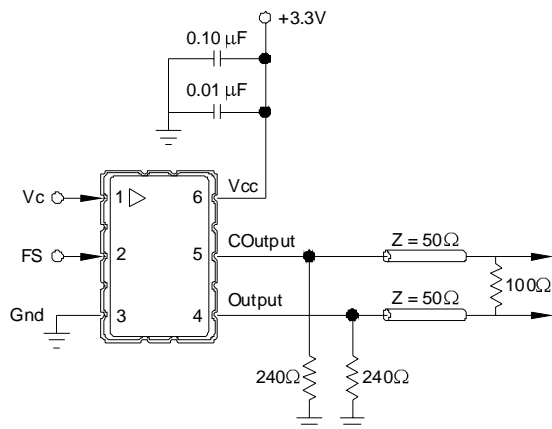

LV-PECL to LV-PECL: For short transmission lengths, the power consumption could be reduced by removing the 100Ω resistor and doubling the value of the pull down resistors.

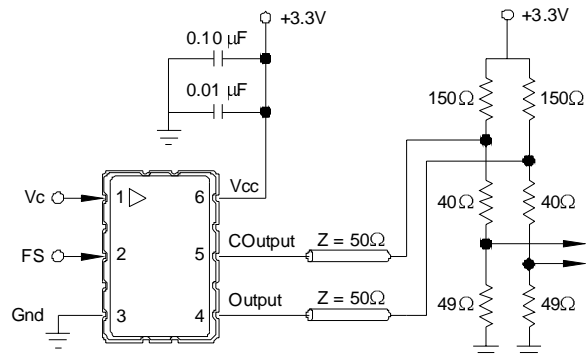

LV-PECL to LVDS: Restricted for short transmission lengths. Configuration may require modification depending on LVDS receiver.

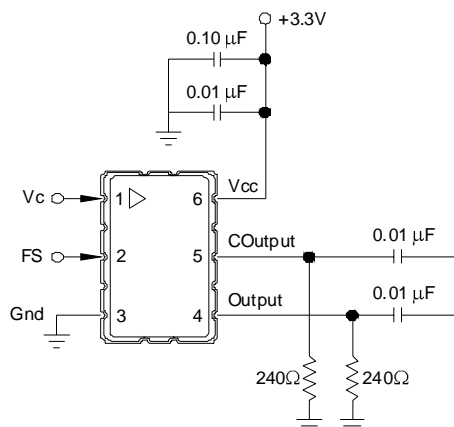

Functional Test: Allows standard power supply configuration. Since AC coupled, the LV-PECL levels cannot be measured.

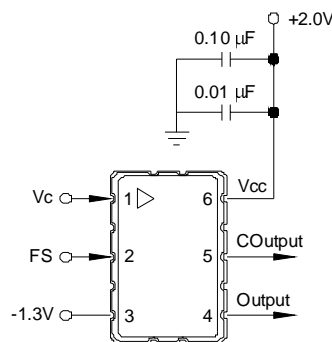

Production Test: Allows direct DC coupling into 50Ω measurement equipment. Must bias the power supplies as shown. Similar to Figure 1.

VS-751 Voltage Controlled SAW Oscillator

Typical Characteristics

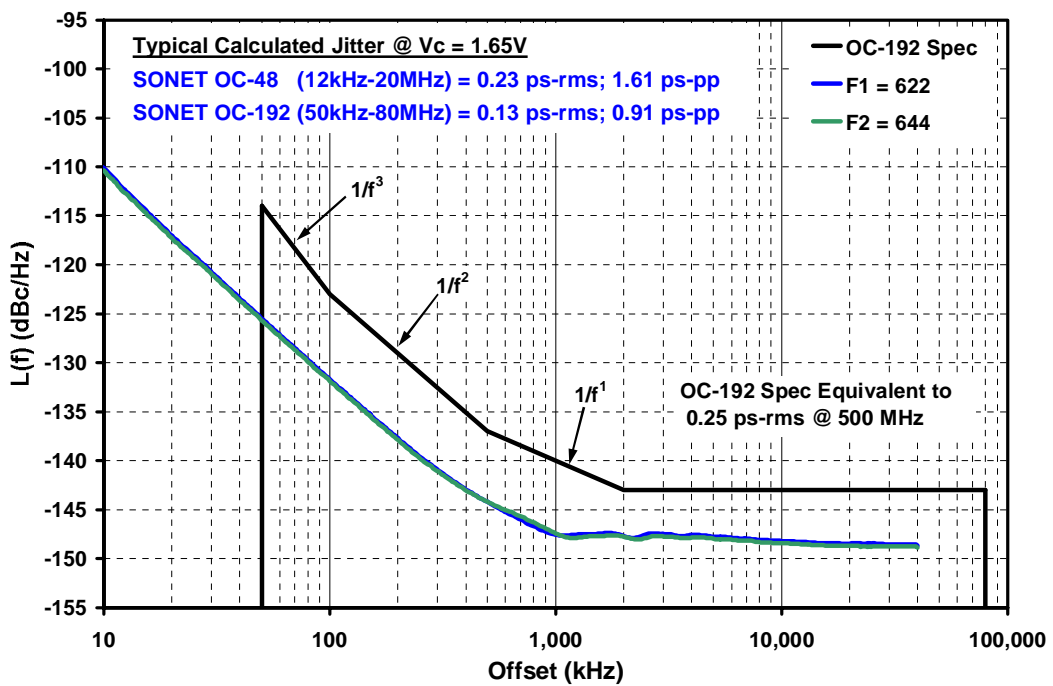
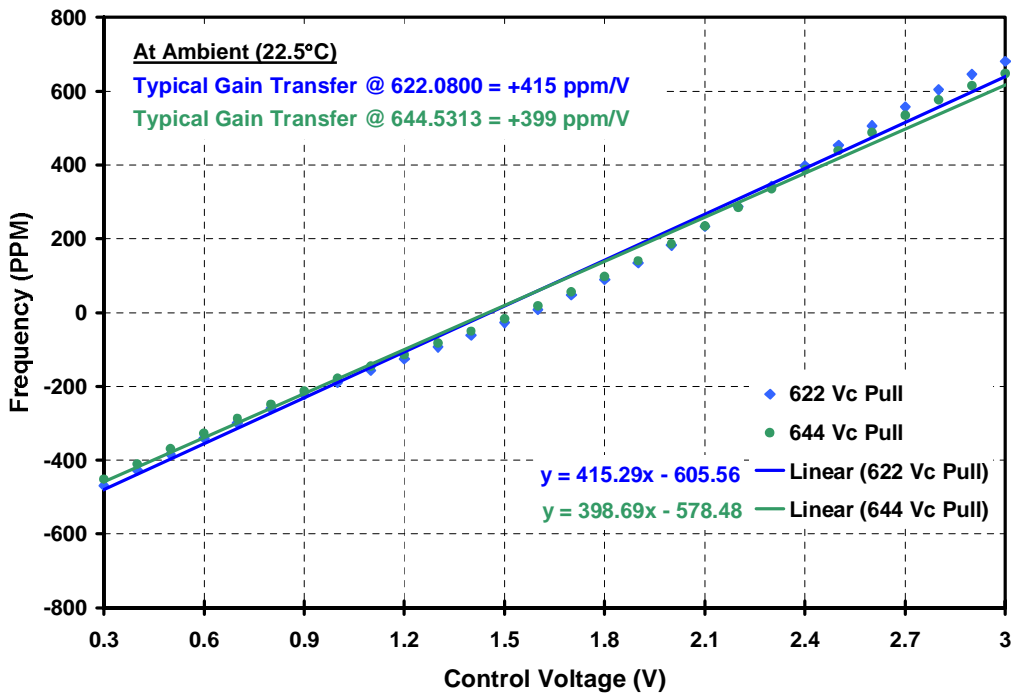

VS-751 Voltage Controlled SAW Oscillator

Reliability

VI qualification includes aging at various extreme temperatures, shock and vibration, temperature cycling, and IR reflow simulation. The VS-751 family is capable of meeting the following qualification tests:

Environmental Compliance

Parameter	Conditions
Mechanical Shock	MIL-STD-883, Method 2002
Mechanical Vibration	MIL-STD-883, Method 2007
Solderability	MIL-STD-883, Method 2003
Gross and Fine Leak	MIL-STD-883, Method 1014
Resistance to Solvents	MIL-STD-883, Method 2016

Handling Precautions

Although ESD protection circuitry has been designed into the VS-751 proper precautions should be taken when handling and mounting. VI employs a human body model (HBM) and a charged-device model (CDM) for ESD susceptibility testing and design protection evaluation.

ESD Ratings

Model	Minimum	Conditions
Human Body Model	1500 V	MIL-STD 883, Method 3015
Charged Device Model	1000 V	JEDEC, JESD22-C101

Reflow Profile (IPC/JEDEC J-STD-020C)

Parameter	Symbol	Value
PreHeat Time	t_s	60 sec Min, 180 sec Max
Ramp Up	R_{UP}	3 °C/sec Max
Time Above 217 °C	t_L	60 sec Min, 150 sec Max
Time To Peak Temperature	t_{AMB-P}	480 sec Max
Time At 260 °C	t_P	20 sec Min, 40 sec Max
Ramp Down	R_{DN}	6 °C/sec Max

The device has been qualified to meet the JEDEC standard for Pb-Free assembly. The temperatures and time intervals listed are based on the Pb-Free small body requirements. The temperatures refer to the topside of the package, measured on the package body surface. The VS-751 device is hermetically sealed so an aqueous wash is not an issue.

Terminal Plating: Electroless Gold Plate over Nickel Plate

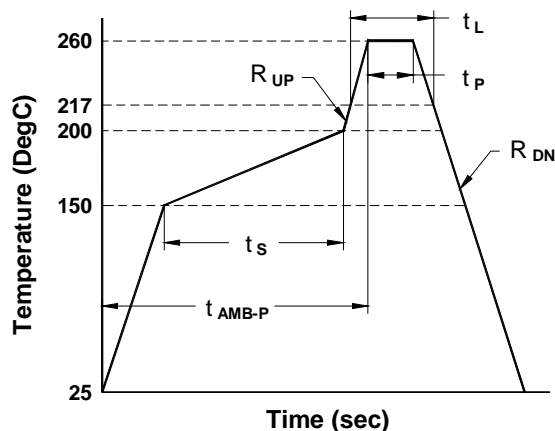

VS-751 Voltage Controlled SAW Oscillator

Standard Frequencies (MHz)

531.2500 P8	569.1964 P9	622.0800 P2	624.6938 PD	625.0000 P3	627.3296 P7
629.9878 PA	644.5313 P4	657.4219 PB	666.5143 P5	669.3266 R3	669.6429 R1
672.1627 R5	690.5692 R4	693.4830 R6	693.7500 R8	707.3527 TC	777.6000 T4
805.6641 TA					

1. Other frequencies available upon request, please contact VI for details.
2. Frequency 1 must be lower than Frequency 2. Not all combinations are available.

Ordering Information

VS - 751 - L F F - H N N - P2 - P4

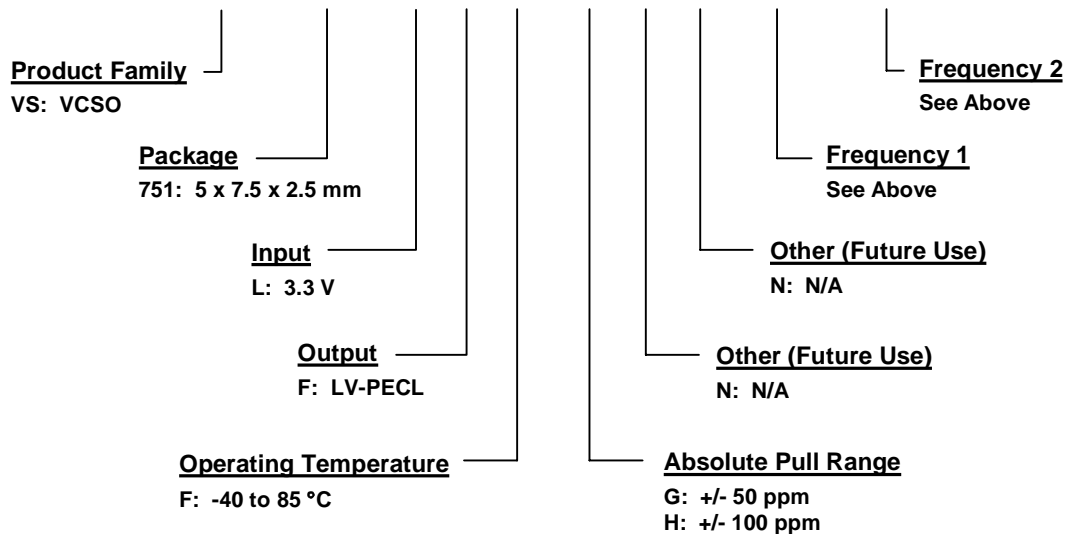

For Additional Information, Please Contact:



USA: Vectron International, 267 Lowell Rd, Hudson, NH 03051 Tel: 1-88-VECTRON-1

Fax: 1-888-FAX-VECTRON

EUROPE: Tel: +49 (0) 3328-4784-17

Fax: +49 (0) 3328-4784-30

ASIA: Tel: +86-21-28909740

Fax: +86-21-28909240

Vectron International reserves the right to make changes to the product(s) and or information contained herein without notice.
No liability is assumed as a result of their use or application. No rights under any patent accompany the sale of any such product(s) or information.