



I²C, 32-Bit, Binary Counter Clock with 64-Bit ID

DS1372

General Description

The DS1372 is a 32-bit binary up counter and 24-bit down counter with a unique 64-bit ID. The counters, ID, configuration, and status registers are accessed using an I²C serial interface. The DS1372 includes a SQW/INT[−] open-drain output that can output either a square wave at one of four predefined frequencies, or it can output an active-low signal when the 24-bit down counter reaches 0.

Applications

Portable Audio and Video Players

Pin Configuration

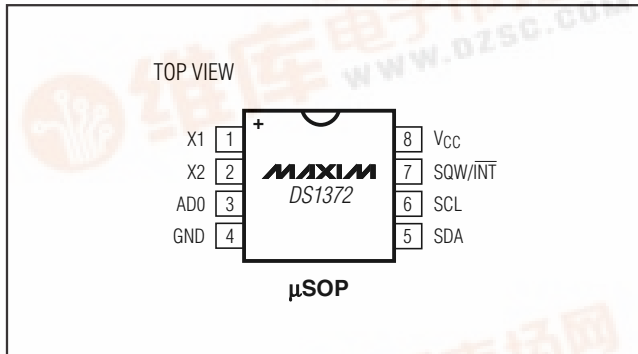

Features

- ◆ Compliant with Microsoft Windows Media[®] DRM 10 for Portable Devices
- ◆ 32-Bit Binary Counter
- ◆ Programmable Alarm
- ◆ 64-Bit Factory-Programmed ID
- ◆ Interrupt Output
- ◆ I²C Serial Interface
- ◆ Two Selectable I²C Addresses
- ◆ 2.4V to 5.5V Operating Voltage Range
- ◆ 1.3V to 5.5V Timekeeping Operating Range
- ◆ -40°C to +85°C Operating Temperature Range
- ◆ 8-Pin μSOP

Ordering Information

PART	TEMP RANGE	PIN-PACKAGE	TOP MARK
DS1372U+	-40°C to +85°C	8 μSOP	1372

+ Denotes a lead-free package. This symbol also appears on the top mark.

Windows Media is a registered trademark of Microsoft Corp.

Typical Operating Circuit

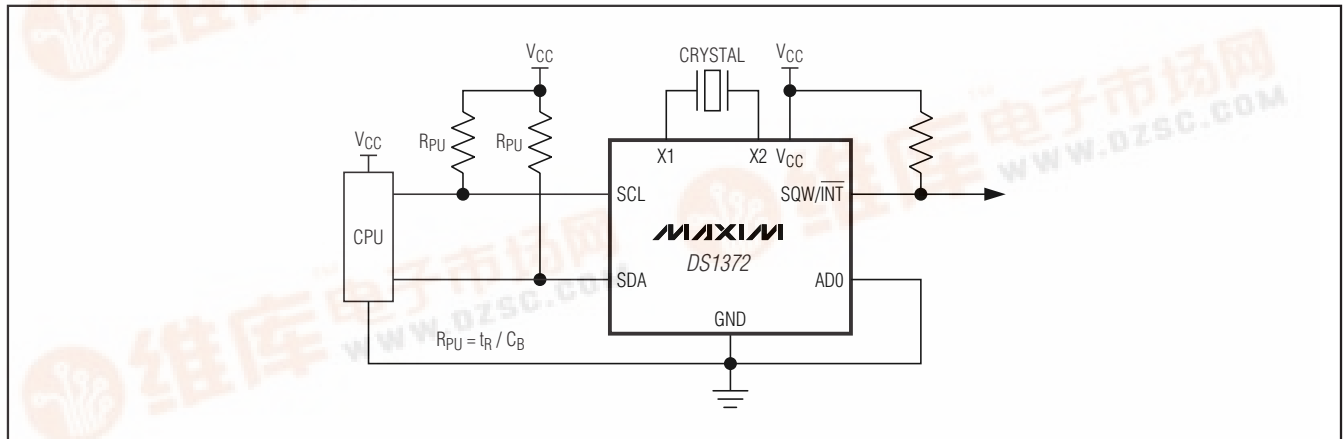

$R_{PU} = t_R / C_B$



I²C, 32-Bit, Binary Counter Clock with 64-Bit ID

ABSOLUTE MAXIMUM RATINGS

Voltage Range on Any Pin Relative to Ground.....-0.3V to +6.0V
 Continuous Power Dissipation (T_A = +70°C)
 (derate 4.5mW/°C above +70°C)360mW

Operating Temperature Range
 (noncondensing).....-40°C to +85°C
 Storage Temperature Range.....-55°C to +125°C
 Soldering Temperature.....See IPC/JEDEC J-STD-020
 specification.

Stresses beyond those listed under "Absolute Maximum Ratings" may cause permanent damage to the device. These are stress ratings only, and functional operation of the device at these or any other conditions beyond those indicated in the operational sections of the specifications is not implied. Exposure to absolute maximum rating conditions for extended periods may affect device reliability.

RECOMMENDED DC ELECTRICAL CHARACTERISTICS

(V_{CC} = 2.4V to 5.5V, T_A = -40°C to +85°C, unless otherwise noted.) (Note 1)

PARAMETER	SYMBOL	CONDITIONS	MIN	TYP	MAX	UNITS
Supply Voltage	V _{CC}	Operating voltage range (Notes 2 and 3)	2.4		5.5	V
		Timekeeping operating range (Notes 2 and 4)	1.3		5.5	
Active Supply Current	I _{CCA}	(Note 3)		35	90	μA
Standby Current (Oscillator Enabled)	I _{CCS}	$\overline{EOSC} = 0$ (Notes 4 and 5)	SQW = 32kHz	600	1300	nA
			SQW = 0	400	800	
Data Retention (Oscillator Disabled)	I _{DDR}	$\overline{EOSC} = 1$ (Note 4)		25	100	nA
Input Logic 1 AD0, SCL, SDA	V _{IH}	(Note 2)	0.7 x V _{CC}		V _{CC} + 0.3	V
Input Logic 0 AD0, SCL, SDA	V _{IL}	(Note 2)	-0.3		0.3 x V _{CC}	V
Input Leakage AD0, SCL, SDA, SQW/ \overline{INT}	I _{LI}	SDA, SQW/ \overline{INT} high impedance	-1		+1	μA
Output Logic 0	I _{OL}	V _{OL} = 0.4V (V _{CC} > 2.4V), SDA, SQW/ \overline{INT}			3	mA
		V _{OL} = 0.2V _{CC} (1.3V < V _{CC} < 2.4V), SQW/ \overline{INT}			0.250	

ELECTRICAL CHARACTERISTICS

(V_{CC} = 2.4V to 5.5V, T_A = -40°C to +85°C, unless otherwise noted.) (Note 1)

PARAMETER	SYMBOL	CONDITIONS	MIN	TYP	MAX	UNITS
SCL Clock Frequency (Note 6)	f _{SCL}	Fast mode	100		400	kHz
		Standard mode	0.04		100.00	
Bus-Free Time Between a STOP and START Condition	t _{BUF}	Fast mode	1.3			μs
		Standard mode	4.7			
Hold Time (Repeated) START Condition (Note 7)	t _{HD:STA}	Fast mode	0.6			μs
		Standard mode	4.0			
Low Period of SCL Clock	t _{LOW}	Fast mode	1.3			μs
		Standard mode	4.7			
High Period of SCL Clock	t _{HIGH}	Fast mode	0.6			μs
		Standard mode	4.0			
Setup Time for Repeated START Condition	t _{SU:STA}	Fast mode	0.6			μs
		Standard mode	4.7			
Data Hold Time (Notes 8 and 9)	t _{HD:DAT}	Fast mode	0		0.9	μs
		Standard mode	0			

I²C, 32-Bit, Binary Counter Clock with 64-Bit ID

ELECTRICAL CHARACTERISTICS (continued)

(V_{CC} = 2.4V to 5.5V, T_A = -40°C to +85°C, unless otherwise noted.) (Note 1)

PARAMETER	SYMBOL	CONDITIONS	MIN	TYP	MAX	UNITS
Data Setup Time (Note 10)	t _{SU:DAT}	Fast mode	100			ns
		Standard mode	250			
Rise Time of SDA and SCL Signals (Note 11)	t _R	Fast mode	20 + 0.1C _B		300	ns
		Standard mode	20 + 0.1C _B		1000	
Fall Time of SDA and SCL Signals (Note 11)	t _F	Fast mode	20 + 0.1C _B		300	ns
		Standard mode	20 + 0.1C _B		300	
Setup Time for STOP Condition	t _{SU:STO}	Fast mode	0.6			μs
		Standard mode	4.0			
Capacitive Load for Each Bus Line (Note 11)	C _B				400	pF
I/O Capacitance	C _{I/O}			10		pF
SCL Spike Suppresion	TSP			30		ns
Oscillator Stop Flag (OSF) Delay (Note 12)	t _{OSF}			100		ms
Timeout Interval (Note 13)	T _{TIMEOUT}		25		35	ms

CRYSTAL SPECIFICATIONS

PARAMETER	SYMBOL	MIN	TYP	MAX	UNITS
Nominal Frequency	f _O		32.768		kHz
Capacitive Load	C _L		12.5		pF
Equivalent Series Resistance	ESR			50	kΩ

Note 1: Limits at -40°C are guaranteed by design and not production tested.

Note 2: All voltages are referenced to ground.

Note 3: SCL clocking at maximum frequency = 400kHz.

Note 4: Specified with I²C bus inactive, SCL = SDA = V_{CC}.

Note 5: Measured with a 32.768kHz crystal attached to the X1 and X2 pins.

Note 6: The I²C minimum operating frequency is imposed by the requirement of timeout period.

Note 7: The first clock pulse is generated after this period.

Note 8: A device must internally provide a hold time of at least 300ns for the SDA signal (referred to as the V_{IHMIN} of the SCL signal) to bridge the undefined region of the falling edge of SCL.

Note 9: The maximum t_{HD:DAT} must only be met if the device does not stretch the low period (t_{LOW}) of the SCL signal.

Note 10: A fast-mode device can be used in a standard-mode system, but the requirement t_{SU:DAT} ≥ 250ns must then be met. This is automatically the case if the device does not stretch the low period of the SCL signal. If such a device does stretch the low period of the SCL signal, it must output the next data bit to the SDA line t_{R(MAX)} + t_{SU:DAT} = 1000 + 250 = 1250ns before the SCL line is released.

Note 11: C_B = Total capacitance of one bus line in pF.

Note 12: The parameter t_{OSF} is the period of time the oscillator must be stopped for the OSF flag to be set over the voltage range of 2.4V ≤ V_{CC} ≤ V_{CC(MAX)}.

Note 13: The DS1372 can detect any single SCL clock held low longer than T_{TIMEOUT} (MIN). The I²C interface is in reset state and can receive a new START condition when SCL is held low for at least T_{TIMEOUT} (MAX). Once the part detects this condition the SDA output is released. The oscillator must be running for this function to work.

I²C, 32-Bit, Binary Counter Clock with 64-Bit ID

Pin Description

PIN	NAME	FUNCTION
1, 2	X1, X2	Connections for Standard 32.768kHz Quartz Crystal. The internal oscillator circuitry is designed for operation with a crystal having a 12.5pF specified load capacitance (C _L). Pin X1 is the input to the oscillator and can optionally be connected to an external 32.768kHz oscillator. The output of the internal oscillator, pin X2, is floated if an external oscillator is connected to pin X1.
3	AD0	Slave Address Input. This pin is the slave address input for the I ² C serial interface and is used to access multiple devices on the same bus. To select the device, the address value on the pin must match the corresponding bit in the device addresses. This pin can be connected to V _{CC} or ground or be driven to a logic-high or logic-low level.
4	GND	Ground
5	SDA	Serial Data Input/Output. This pin is the data input/output for the I ² C serial interface. The SDA pin is open drain and requires an external pullup resistor.
6	SCL	Serial Clock Input. This pin is the clock input for the I ² C serial interface and is used to synchronize data movement on the serial interface.
7	SQW/ $\overline{\text{INT}}$	Square Wave or Active-Low Interrupt Open-Drain Output. This pin is used to output the square wave or alarm interrupt signal. The function of this pin is selected by the state of the INTCN control bit. This pin is open drain and requires an external pullup resistor.
8	V _{CC}	DC Power Pin. This pin should be decoupled using a 0.1μF or 1.0μF capacitor.

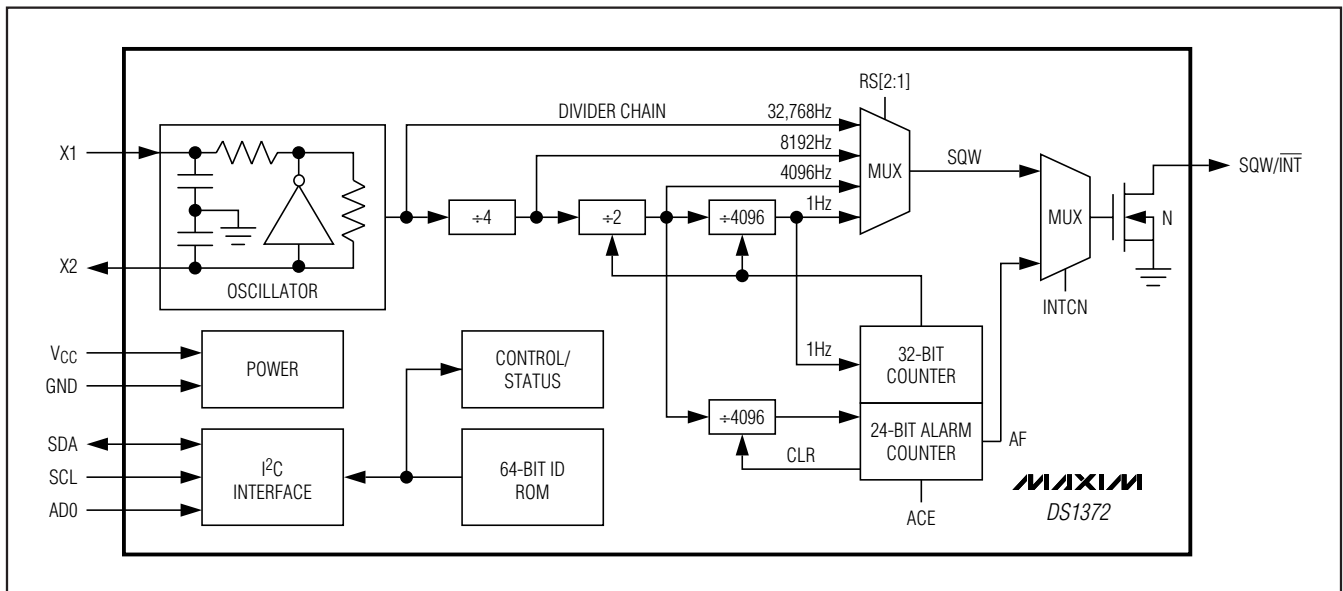

Figure 1. Block Diagram

I²C, 32-Bit, Binary Counter Clock with 64-Bit ID

Detailed Description

The DS1372 is a 32-bit binary counter designed to continuously count time in seconds. An additional counter is provided that can generate a periodic alarm. An interrupt output can be driven when the alarm condition is met. The device includes a unique, factory-lasered 64-bit ROM ID. The device is programmed serially by an I²C bidirectional bus.

Oscillator Circuit

The DS1372 is designed to operate with a standard 32.768kHz quartz crystal having a 12.5pF specified load capacitance (C_L). For more information on crystal selection and crystal layout considerations, refer to Application Note 58: *Crystal Considerations with Dallas Real-Time Clocks (RTCs)*. An external 32.768kHz oscillator can be used as the DS1372's time base. In this configuration, the X1 pin is connected to the external oscillator signal and the X2 is floated. The $\overline{\text{EOSC}}$ bit in the Control Register controls oscillator operation.

Clock Accuracy

The initial clock accuracy is dependent upon the accuracy of the crystal and the accuracy of the match between the capacitive load of the oscillator circuit and the capacitive load for which the crystal was trimmed. Additional error is added by crystal frequency drift caused by temperature shifts. External circuit noise coupled into the oscillator circuit can result in the clock running fast. Figure 2 shows a typical PCB layout for isolation of the crystal and oscillator from noise. Refer to Application Note 58: *Crystal Considerations with Dallas Real-Time Clocks (RTCs)* for detailed information.

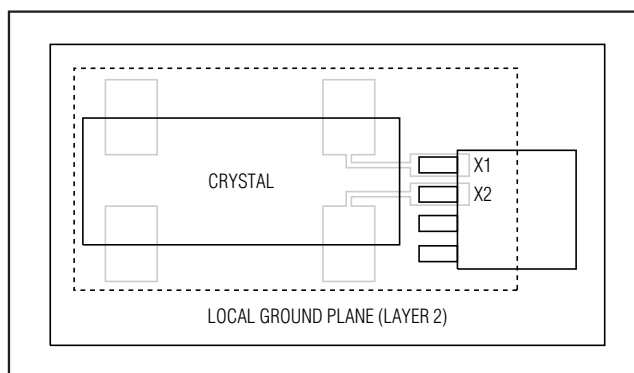

Figure 2. Layout Example

Operation

The block diagram in Figure 1 shows the DS1372's main elements. As shown, communications to and from the DS1372 occur serially over an I²C bidirectional bus. The DS1372 operates as a slave device on the serial bus. Access is obtained by implementing a START condition and providing a device identification code followed by a register address. Subsequent registers can be accessed sequentially until a STOP condition is executed.

Address Map

Table 1 shows the address map for the DS1372 registers. During a multibyte access, when the address pointer reaches the end of the register space (10h) it wraps around to location 00h. On an I²C START or address pointer incrementing to location 00h, the current time is transferred to a second set of registers. The time information is read from these secondary registers, while the clock may continue to run. This eliminates the need to reread the registers in case the main registers update during a read.

Clock Operation

The clock counter is a 32-bit up counter. The counter counts up once per second. The contents can be read or written by accessing the address range 00h–03h. On an I²C START, or when the address pointer rolls over to 00h, the current value is latched into a register, which is output on the serial data line while the counter continues to increment. When writing to the registers, the divider chain is reset when register 00h is written. Once the divider chain is reset, the remaining clock registers should be written within one second to avoid rollover issues. Additionally, to avoid rollover issues the clock registers must also be written from LSB to MSB, and all four bytes should always be written.

I²C, 32-Bit, Binary Counter Clock with 64-Bit ID

Alarm Operation

The alarm counter is a 24-bit counter in the address range 04h–06h. When the alarm counter is written, a seed register is written with the alarm counter value. When the alarm counter enable (ACE) bit in the Control Register is set to 1, the counter begins counting down from the seed value. When the counter reaches zero, it sets the AF bit in the Status Register, if the AF bit is not already set. If the AIE and INTCN bits are both set to a logic 1, the SQW/INT pin goes low and remains low until AF is written to logic 0. The counter is then

reloaded with the seed value and the countdown restarts. When the counter is read, the current counter value is latched into a register, which is output on the serial data line while the counter continues to decrement. The counter is disabled if the seed value is zero or if ACE = 0. Whenever the ACE is set from 0 to 1, the counter is reloaded with the current seed value and the counter begins to count down. **Note:** When initializing or changing the alarm value, the ACE bit should be enabled after writing the alarm counter bytes.

Table 1. DS1372 Address Map

ADDRESS	REGISTER	BIT 7	BIT 6	BIT 5	BIT 4	BIT 3	BIT 2	BIT 1	BIT 0
00h	Clock	—	Seconds Counter Byte 0						LSB
01h	Clock	—	Seconds Counter Byte 1						—
02h	Clock	—	Seconds Counter Byte 2						—
03h	Clock	MSB	Seconds Counter Byte 3						—
04h	Alarm	—	Alarm Counter Byte 0						LSB
05h	Alarm	—	Alarm Counter Byte 1						—
06h	Alarm	MSB	Alarm Counter Byte 2						—
07h	Control	$\overline{\text{EOSC}}$	ACE	0	0	INTCN	RS2	RS1	AIE
08h	Status	OSF	0	0	0	0	0	0	AF
09h	ID	Model Number							
0Ah	ID	Serial Number Byte 0							
0Bh	ID	Serial Number Byte 1							
0Ch	ID	Serial Number Byte 2							
0Dh	ID	Serial Number Byte 3							
0Eh	ID	Serial Number Byte 4							
0Fh	ID	Serial Number Byte 5							
10h	ID	CRC							

Note: Unless otherwise specified, the states of the registers are undefined when power is first applied. Bits shown as 0 always read back as 0.

I²C, 32-Bit, Binary Counter Clock with 64-Bit ID

Special Purpose Registers

The DS1372 has two additional registers that control the alarm counter and interrupts: Control Register (07h) and Status Register (08h).

Control Register (07h)

Bit #	7	6	5	4	3	2	1	0
Name	EOSC	ACE	0	0	INTCN	RS2	RS1	AIE
Reset	0	0	0	0	1	1	1	0

Control Register (07h)

Bit 7: Enable Oscillator (EOSC). When set to logic 0, the oscillator is started. When set to logic 1, the oscillator is stopped. This bit is clear (logic 0) when power is first applied.

Bit 6: Alarm Counter Enable (ACE). When set to logic 1, the alarm counter is enabled. If alarm counter seed register has a nonzero value, the counter runs and sets the AF bit to 1 when the counter reaches 0. When set to logic 0, the alarm counter is disabled, and the counter can be used as RAM. This bit is clear (logic 0) when power is first applied.

Bit 3: Interrupt Control (INTCN). This bit controls the SQW/ $\overline{\text{INT}}$ signal. When the INTCN bit is set to logic 0, a square wave is output on the SQW/ $\overline{\text{INT}}$ pin whose frequency is defined by bits RS2 and RS1, according to Table 2. The oscillator must also be enabled for the square wave to be output. When the INTCN bit is set to logic 1, this permits the AF bit in the Status Register to assert SQW/ $\overline{\text{INT}}$ (provided that ACE and AIE are also enabled) whenever AF = 1. If ACE = 1, the alarm flag is always set on an alarm condition, regardless of the state of the INTCN bit. The INTCN bit is set to logic 1 when power is first applied.

Bits 2 and 1: Rate Select (RS[2:1]). These bits control the frequency of the square-wave output when the square wave has been enabled. Table 2 shows the square-wave frequencies that can be selected with the RS bits. These bits are both set (logic 1) when power is first applied.

Bit 0: Alarm Interrupt Enable (AIE). When set to a logic 1, this bit permits the alarm flag (AF) to assert SQW/ $\overline{\text{INT}}$ (when INTCN = 1). The AIE bit is disabled (logic 0) when power is first applied.

Table 2. Square-Wave/Interrupt Output Frequencies

INTCN	ACE	AIE	RS2	RS1	SQW/ $\overline{\text{INT}}$ OUTPUT
0	X	X	0	0	1Hz
0	X	X	0	1	4.096kHz
0	X	X	1	0	8.192kHz
0	X	X	1	1	32.768kHz
1	1	1	X	X	Interrupt

Note: When interrupt operation is enabled, the SQW/ $\overline{\text{INT}}$ output is the inverse of the AF bit.

I²C, 32-Bit, Binary Counter Clock with 64-Bit ID

Status Register (08h)

Bit #	7	6	5	4	3	2	1	0
Name	OSF	0	0	0	0	0	0	AF
Reset	1	0	0	0	0	0	0	0

Status Register (08h)

Bit 7: Oscillator Stop Flag (OSF). A logic 1 in this bit indicates that the oscillator either is stopped or was stopped for some period of time and may be used to judge the validity of the timekeeping data. This bit is set to logic 1 anytime the oscillator stops. The following are examples of conditions that can cause the OSF bit to be set:

- 1) The first time power is applied.
- 2) The voltage present on V_{CC} is insufficient to support oscillation.
- 3) The $\overline{\text{EOSC}}$ bit is turned off.
- 4) External influences on the crystal (i.e., noise, leakage, etc.) exist.

This bit remains at logic 1 until written to logic 0.

Bits 6 to 1: These bits always read back as logic 0.

Bit 0: Alarm Flag (AF). A logic 1 in the AF bit indicates that the alarm counter reached zero. If the AIE and INTCN bits are both set to logic 1, the SQW/ $\overline{\text{INT}}$ pin goes low and remains low until AF is written to logic 0. This bit can only be written to logic 0. Attempting to write logic 1 leaves the value unchanged.

ID Register

A unique 64-bit lasered serial number is located in the address range 09h–10h. This serial number is divided into three parts. The first byte in register 09h contains a model number to identify the DS1372 device type. Registers 0Ah–0Fh contain a unique binary number. Register 10h contains a CRC byte used to validate the data in registers 09h–0Fh. All eight bytes of the serial number are read-only registers. The CRC byte is generated with the polynomial equal to $x^8 + x^5 + x^4 + 1$ (see Figure 3).

The DS1372 is manufactured such that no two devices contain an identical number in locations 0Ah–0Fh.

I²C Serial Data Bus

The DS1372 supports a bidirectional I²C serial bus and data transmission protocol (Figure 4). A device that sends data onto the bus is defined as a transmitter, and a device receiving data is defined as a receiver. The device that controls the message is called a master. The devices that are controlled by the master are slaves. The bus must be controlled by a master device that generates the serial clock (SCL), controls the bus access, and generates the START and STOP

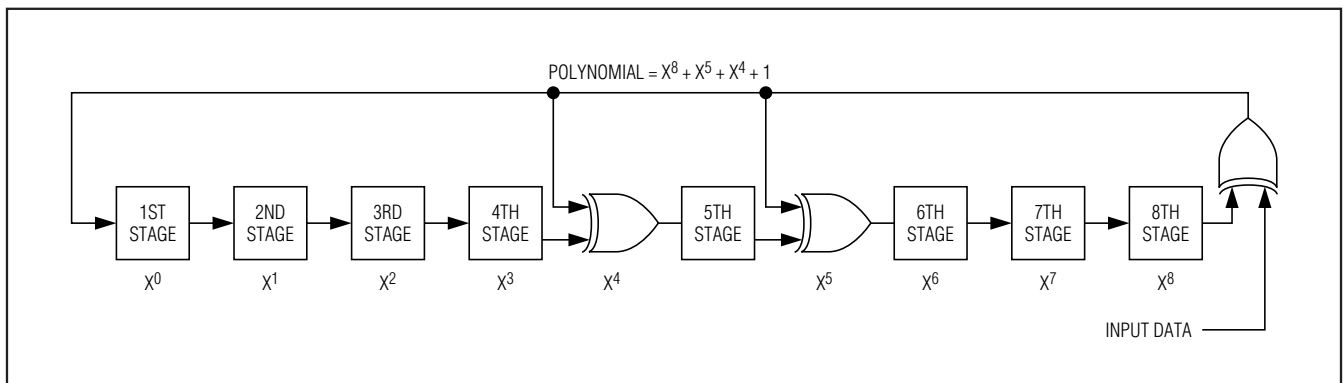

Figure 3. CRC Byte Polynomial

I²C, 32-Bit, Binary Counter Clock with 64-Bit ID

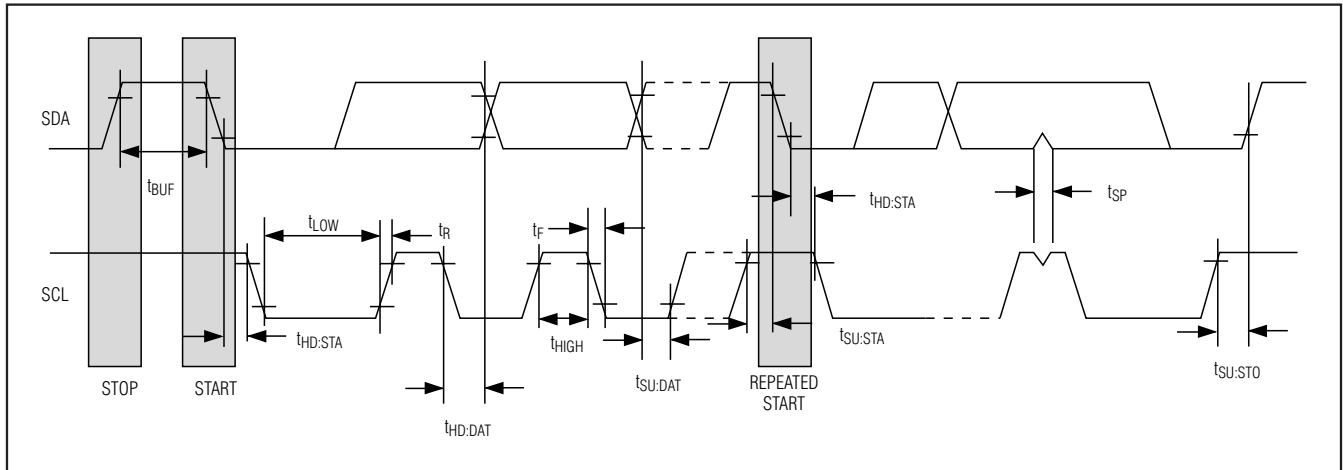

Figure 4. Data Transfer on I²C Serial Bus

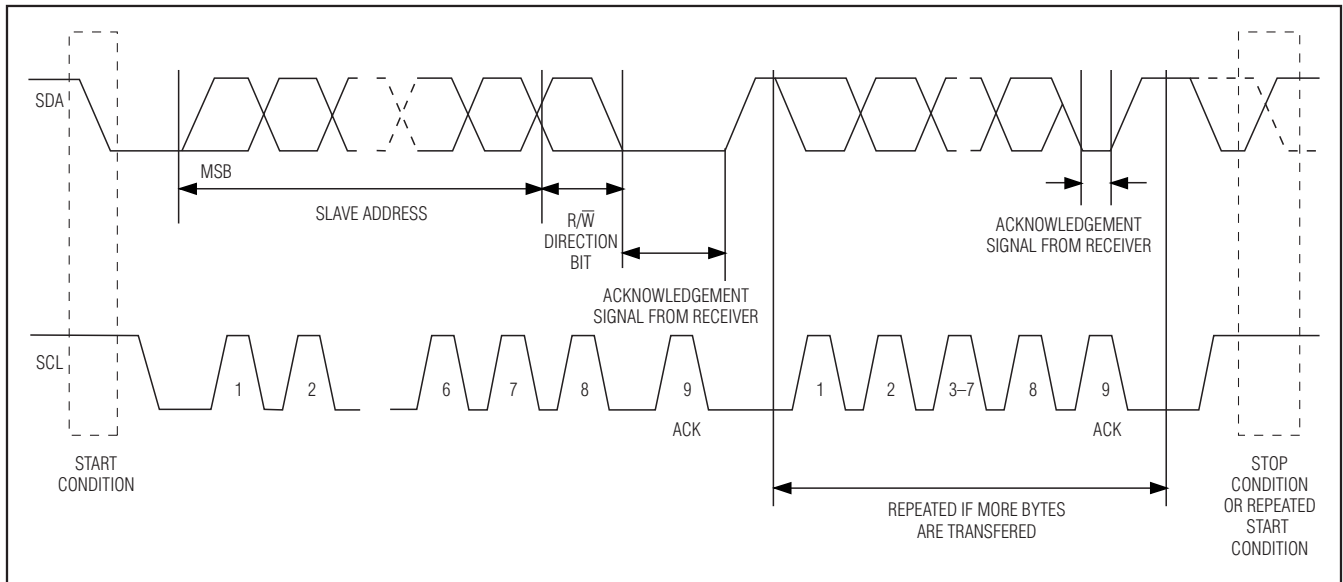

Figure 5. I²C Data Transfer Overview

conditions. The DS1372 operates as a slave on the I²C bus. Connections to the bus are made through the SCL input and open-drain SDA I/O lines. Within the bus specifications, a standard mode (100kHz maximum clock rate) and a fast mode (400kHz maximum clock rate) are defined. The DS1372 works in both modes.

The following bus protocol has been defined (Figure 5):

- Data transfer can be initiated only when the bus is not busy.
- During data transfer, the data line must remain stable whenever the clock line is high. Changes in the data line while the clock line is high are interpreted as control signals.

I²C, 32-Bit, Binary Counter Clock with 64-Bit ID

Accordingly, the following bus conditions have been defined:

Bus not busy: Both data and clock lines remain high.

Start data transfer: A change in the state of the data line from high to low, while the clock line is high, defines a START condition.

Stop data transfer: A change in the state of the data line from low to high, while the clock line is high, defines a STOP condition.

Data valid: The state of the data line represents valid data when, after a START condition, the data line is stable for the duration of the high period of the clock signal. The data on the line must be changed during the low period of the clock signal. There is one clock pulse per bit of data.

Each data transfer is initiated with a START condition and terminated with a STOP condition. The number of data bytes transferred between the START and the STOP conditions is not limited, and is determined by the master device. The information is transferred byte-wise and each receiver acknowledges with a ninth bit.

Acknowledge: Each receiving device, when addressed, is obliged to generate an acknowledge after the reception of each byte. The master device must generate an extra clock pulse, which is associated with this acknowledge bit.

A device that acknowledges must pull down the SDA line during the acknowledge clock pulse in such a way that the SDA line is stable low during the high period of the acknowledge-related clock pulse. Of course, setup and hold times must be taken into account. A master must signal an end of data to the slave by not generating an acknowledge bit on the last byte that has been clocked out of the slave. In this case, the slave must leave the data line high to enable the master to generate the STOP condition.

Timeout: To avoid an unintended I²C interface timeout, SCL should not be held low longer than 25ms. The I²C interface is in the reset state and can receive a new START condition when SCL is held low for at least 35ms. When the part detects this condition, SDA is released and allowed to float. For the timeout function to work, the oscillator must be enabled and running.

Depending upon the state of the $\overline{R/W}$ bit, two types of data transfer are possible:

- 1) Data transfer from a master transmitter to a slave receiver.** The first byte transmitted by the master is the slave address. Next follows a number of data bytes. The slave returns an acknowledge bit after each received byte. Data is transferred with the most significant bit (MSB) first.
- 2) Data transfer from a slave transmitter to a master receiver.** The first byte (the slave address) is transmitted by the master. The slave then returns an acknowledge bit. Next follows a number of data bytes transmitted by the slave to the master. The master returns an acknowledge bit after all received bytes other than the last byte. At the end of the last received byte, a not acknowledge is returned.

The master device generates all the serial clock pulses and the START and STOP conditions. A transfer is ended with a STOP condition or with a repeated START condition. Since a repeated START condition is also the beginning of the next serial transfer, the bus will not be released. Data is transferred with the most significant bit (MSB) first.

The DS1372 can operate in the following two modes:

- 1) Slave receiver mode (DS1372 write mode):** Serial data and clock are received through SDA and SCL. After each byte is received an acknowledge bit is transmitted. START and STOP conditions are recognized as the beginning and end of a serial transfer. Address recognition is performed by hardware after reception of the slave address and direction bit (see Figure 6). The slave address byte is the first byte received after the master generates the START condition. The slave address byte contains the 7-bit DS1372 address, which is 110100 and AD0. Each slave address is followed by the direction bit ($\overline{R/W}$), which is zero for a write. The bit position signified by A is compared to the value on the AD0 input pin. After receiving and decoding the slave address byte, the device outputs an acknowledge on the SDA line. After the device acknowledges the slave address and write bit, the master transmits a register address to the device. This sets the register pointer on the device. After setting the register address, the master then transmits each byte of data with the DS1372 acknowledging each byte received. The master generates a STOP condition to terminate the data write.

I²C, 32-Bit, Binary Counter Clock with 64-Bit ID

2) Slave transmitter mode (DS1372 read mode): The first byte is received and handled as in the slave receiver mode. However, in this mode, the direction bit indicates that the transfer direction is reversed. The DS1372 transmits serial data on SDA while the serial clock is input on SCL. START and STOP conditions are recognized as the beginning and end of a serial transfer (see Figure 7). The slave address byte is the first byte received after the master generates the START condition. The slave address byte contains the 7-bit DS1372 address, which is 110100 and AD0. Each slave address is followed by the

direction bit (R/\bar{W}), which is one for a read. The bit position signified by A is compared to the value on the AD0 pin. After receiving and decoding the slave address byte, the device outputs an acknowledge on the SDA line. The DS1372 then begins to transmit data starting with the register address pointed to by the register pointer. If the register pointer is not written to before the initiation of a read mode, the first address that is read is the last one stored in the register pointer. The DS1372 must receive a "not acknowledge" to end a read.

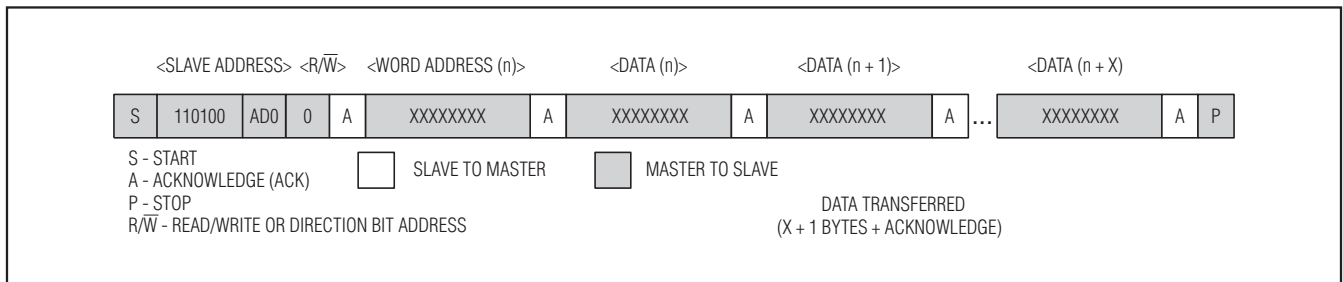

Figure 6. Data Write—Slave Receiver Mode

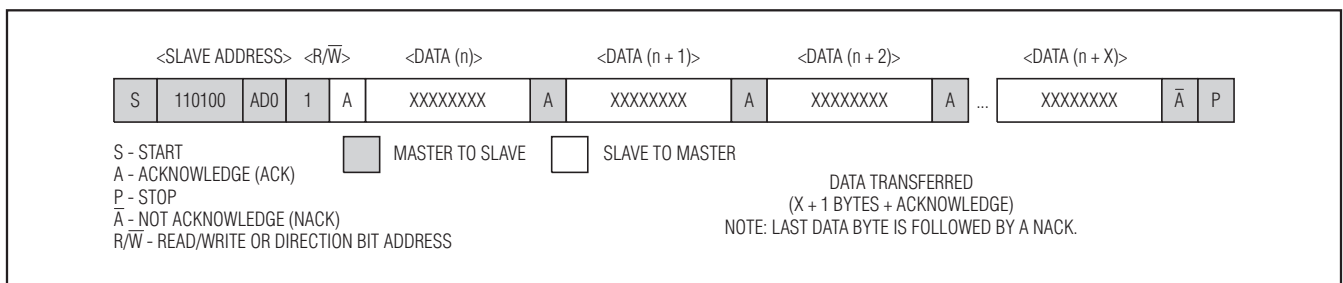

Figure 7. Data Read (from Current Pointer Location)—Slave Transmitter Mode

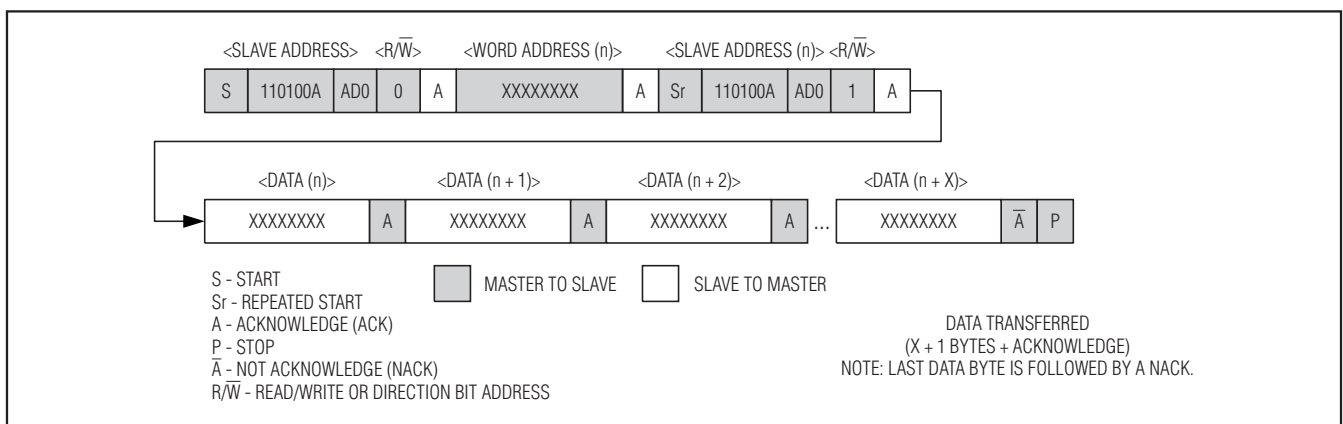

Figure 8. Data Read (Write Pointer, Then Read)—Slave Receive and Transmit

I²C, 32-Bit, Binary Counter Clock with 64-Bit ID

Chip Information

SUBSTRATE CONNECTED TO GROUND
PROCESS: CMOS

Thermal Information

Thermal Resistance (Junction to Ambient) θ_{JA} : 221°C/W
Thermal Resistance (Junction to Case) θ_{JC} : 39°C/W

Package Information

For the latest package outline information, go to www.maxim-ic.com/packages.

PACKAGE	DOCUMENT NO.
8-pin μ SOP	21-0036

Maxim cannot assume responsibility for use of any circuitry other than circuitry entirely embodied in a Maxim product. No circuit patent licenses are implied. Maxim reserves the right to change the circuitry and specifications without notice at any time.

12 Maxim Integrated Products, 120 San Gabriel Drive, Sunnyvale, CA 94086 408-737-7600