

NIKO-SEM

1A Fixed and Adjustable Low Dropout Linear Regulator (LDO)

L1117XG Series
 SOT-223, TO-252,
 TO-220, TO-263
Lead-Free

GENERAL DESCRIPTION

The L1117G Series are positive and low drop-out three-terminal voltage regulators with 1A output current capability. These devices are designed for use in low voltage applications that offers lower dropout voltage and faster transient response.

These devices are fully protected against over current faults, over temperature operation, reversed input polarity, reversed lead insertion, transient voltage spike ...etc.

On-Chips trimming the reference voltage to 2% and features the low dropout of maximum 1.45 volts.

The L1117G Series regulators offer fixed and adjustable voltage options available in the popular industry standard SOT-223, TO-220, TO-252 and TO-263 packages.

FEATURES

- Fixed 1.8V, 2.5V, 2.85V, 3.3V, 5V or adjustable output voltage
- Low dropout voltage: 1.2V typical at up to 1A
- Low ground current
- Fast transient response
- Current & thermal limiting
- Line regulation: 0.5% typical
- Load regulation: 0.5% typical
- SOT-223, TO-220, TO-252, TO-263 package

APPLICATIONS

- 2.85V active SCSI terminators
- 7-15V to 5V linear regulators
- 5V to 2.5V or 3.3V linear regulators
- Low voltage micro-controllers
- Battery Chargers
- Motherboard clock supplies
- Post regulator for switching supplies
- Micro-controllers

ABSOLUTE MAXIMUM RATINGS

- | | | | |
|---|--------------------|--|---------------|
| ● Maximum Supply Voltage | 15V* | ● Operating Junction Temperature Range | 0 to 125 °C |
| ● Power Dissipation | Internally Limited | ● Storage Temperature Range | -40 to 150 °C |
| ● Thermal Resistance Junction to Case, θ_{JC} | 16 °C/W | ● Lead Temperature (Soldering, 10 Seconds) | 260 °C |
| ● Thermal Resistance Junction to Ambient, θ_{JA} | | | |
| SOT-223 | 158 °C/W | | |
| TO-252 | 70 °C/W | | |
| TO-220 | 50 °C/W | | |
| TO-263 | 60 °C/W | | |

* When considering short circuits to ground, the maximum input-to-output differential voltage shall not be allowed greater than approximate 2~3V at values of supply voltage in excess of 10V, continuous short-circuits can exceed the power dissipation ratings and cause eventual destruction.



ELECTRICAL CHARACTERISTICS for ADJUSTABLE(Unless otherwise specified, TA = 25°C)

Parameter	Symbol	Test Conditions	Typical	Limits
Reference Voltage (Adjustable version)	V _{REF}	V _{IN} = 5V, I _{OUT} = 10mA	1.25V	1.23V _{Min} 1.27V _{Max}
Output Voltage (Fixed version)	V _O	V _{IN} = 5V, I _{OUT} = 10mA	V _O	0.98V _{O(Min)} 1.02V _{O(Max)}
Dropout Voltage	V _D	V _{REF} = 1%, I _{OUT} = 1A	1.2V	1.45V
Line Regulation	REG _(LINE)	(V _{OUT} + 1.5V) ≤ V _{IN} ≤ 15V, I _{OUT} = 10mA	0.5%	2%
Load Regulation	REG _(LOAD)	(V _{IN} - V _{OUT}) = 2V, 10mA ≤ I _{OUT} ≤ 1A	0.5%	2.5%
Minimum Load Current	I _O	1.5V ≤ (V _{IN} - V _{OUT}) ≤ 5.75V	10mA	
Adjust Pin Current	I _{ADJ}		55μA	100μA
Current Limit	I _{CL}	V _{IN} - V _{OUT} = 2V	1.2A	1.1A (Min)
RMS Output Noise	V _N		0.003% of V _{OUT}	
Ripple Rejection Ratio	R _A	f = 120Hz, C _{ADJ} = 22μF for ADJ pin, V _{IN} = 5V, I _{OUT} = 1A	72dB	60dB (Min)

ELECTRICAL CHARACTERISTICS for L1117G-1.8(Unless otherwise specified, TA = 25 °C)

Parameter	Symbol	Test Conditions	Typical	Limits
Output Voltage (Fixed version)	V _O	V _{IN} = 5V, I _{OUT} = 10mA	V _O	1.764V _(Min) 1.836V _(Max)
Dropout Voltage	V _D	V _O = 1%, I _{OUT} = 1A	1.2V	1.45V
Line Regulation	REG _(LINE)	(V _{OUT} + 1.5V) ≤ V _{IN} ≤ 15V, I _{OUT} = 10mA	0.5%	2.0%
Load Regulation	REG _(LOAD)	(V _{IN} - V _{OUT}) = 2V, 10mA ≤ I _{OUT} ≤ 1A	0.5%	2.0%
Quiescent Current	I _Q		5mA	10mA
Current Limit	I _{CL}	V _{IN} - V _{OUT} = 2V	1.2A	1.1A (Min)
RMS Output Noise	V _N		0.003% of V _{OUT}	
Ripple Rejection Ratio	R _A	f = 120Hz, Co=22μF, V _{IN} = 5V, I _{OUT} = 1A	72dB	60dB (Min)

ELECTRICAL CHARACTERISTICS for L1117G-2.5(Unless otherwise specified, $T_A = 25\text{ }^\circ\text{C}$)

Parameter	Symbol	Test Conditions	Typical	Limits
Output Voltage (Fixed version)	V_O	$V_{IN} = 5V, I_{OUT} = 10mA$	V_O	$2.45V_{(Min)}$ $2.55V_{(Max)}$
Dropout Voltage	V_D	$V_O = 1\%, I_{OUT} = 1A$	1.2V	1.45V
Line Regulation	$REG_{(LINE)}$	$(V_{OUT} + 1.5V) \leq V_{IN} \leq 15V, I_{OUT} = 10mA$	0.5%	2.0%
Load Regulation	$REG_{(LOAD)}$	$(V_{IN} - V_{OUT}) = 2V, 10mA \leq I_{OUT} \leq 1A$	0.5%	2.0%
Quiescent Current	I_Q		5mA	10mA
Current Limit	I_{CL}	$V_{IN} - V_{OUT} = 2V$	1.2A	1.1A (Min)
RMS Output Noise	V_N		0.003% of V_{OUT}	
Ripple Rejection Ratio	R_A	$f = 120Hz, C_o = 22\mu F, V_{IN} = 5V, I_{OUT} = 1A$	72dB	60dB (Min)

ELECTRICAL CHARACTERISTICS for L1117G-2.85(Unless otherwise specified, $T_A = 25\text{ }^\circ\text{C}$)

Parameter	Symbol	Test Conditions	Typical	Limits
Output Voltage (Fixed version)	V_O	$V_{IN} = 5V, I_{OUT} = 10mA$	V_O	$2.793V_{(Min)}$ $2.907V_{(Max)}$
Dropout Voltage	V_D	$V_O = 1\%, I_{OUT} = 1A$	1.2V	1.45V
Line Regulation	$REG_{(LINE)}$	$(V_{OUT} + 1.5V) \leq V_{IN} \leq 8V, I_{OUT} = 10mA$	0.5%	2.0%
Load Regulation	$REG_{(LOAD)}$	$(V_{IN} - V_{OUT}) = 2V, 10mA \leq I_{OUT} \leq 1A$	0.5%	2.0%
Quiescent Current	I_Q		5mA	10mA
Current Limit	I_{CL}	$V_{IN} - V_{OUT} = 2V$	1.2A	1.1A (Min)
RMS Output Noise	V_N		0.003% of V_{OUT}	
Ripple Rejection Ratio	R_A	$f = 120Hz, C_o = 22\mu F, V_{IN} = 5V, I_{OUT} = 1A$	72dB	60dB (Min)

ELECTRICAL CHARACTERISTICS for L1117G-3.3(Unless otherwise specified, T_A = 25 °C)

Parameter	Symbol	Test Conditions	Typical	Limits
Output Voltage (Fixed version)	V _O	V _{IN} = 5V, I _{OUT} = 10mA	V _O	3.234V _(Min) 3.367V _(Max)
Dropout Voltage	V _D	V _O = 1%, I _{OUT} = 1A	1.2V	1.45V
Line Regulation	REG _(LINE)	(V _{OUT} + 1.5V) ≤ V _{IN} ≤ 15V, I _{OUT} = 10mA	0.5%	2.0%
Load Regulation	REG _(LOAD)	(V _{IN} - V _{OUT}) = 2V, 10mA ≤ I _{OUT} ≤ 1A	0.5%	2.0%
Quiescent Current	I _Q		5mA	10mA
Current Limit	I _{CL}	V _{IN} - V _{OUT} = 2V	1.2A	1.1A (Min)
RMS Output Noise	V _N		0.003% of V _{OUT}	
Ripple Rejection Ratio	R _A	f = 120Hz, C _O =22μF, V _{IN} = 5V, I _{OUT} = 1A	72dB	60dB (Min)

ELECTRICAL CHARACTERISTICS for L1117G-5(Unless otherwise specified, T_A = 25 °C)

Parameter	Symbol	Test Conditions	Typical	Limits
Output Voltage (Fixed version)	V _O	V _{IN} = 8V, I _{OUT} = 10mA	V _O	4.90V _(Min) 5.10V _(Max)
Dropout Voltage	V _D	V _O = 1%, I _{OUT} = 1A	1.2V	1.45V
Line Regulation	REG _(LINE)	(V _{OUT} + 1.5V) ≤ V _{IN} ≤ 15V, I _{OUT} = 10mA	0.5%	1.0%
Load Regulation	REG _(LOAD)	(V _{IN} - V _{OUT}) = 2V, 10mA ≤ I _{OUT} ≤ 1A	0.5%	1.0%
Quiescent Current	I _Q		5mA	10mA
Current Limit	I _{CL}	V _{IN} - V _{OUT} = 2V	1.2A	1.1A (Min)
RMS Output Noise	V _N		0.003% of V _{OUT}	
Ripple Rejection Ratio	R _A	f = 120Hz, C _O =22μF, V _{IN} = 8V, I _{OUT} = 1A	72dB	60dB (Min)

DEVICE SELECTION GUIDE

Device	L1117XG	L1117XG-1.8	L1117XG-2.5	L1117XG-2.85	L1117XG-3.3	L1117XG-5
Voltage Version	ADJ	1.8	2.5	2.85	3.3	5
Package	Any package	Any package	Any package	Any package	Any package	Any package
Marking	L1117XG	L1117XG-1.8	L1117XG-2.5	L1117XG-2.85	L1117XG-3.3	L1117XG-5

DEVICE	PACKAGE	MARKING
L1117XG	L, D, S, T	L1117XG
L1117XG-1.8	L, D, S, T	L1117XG-1.8
L1117XG-2.5	L, D, S, T	L1117XG-2.5
L1117XG-2.85	L, D, S, T	L1117XG-2.85
L1117XG-3.3	L, D, S, T	L1117XG-3.3
L1117XG-5	L, D, S, T	L1117XG-5

L: SOT-223

D: TO-252

S: TO-263

T: TO-220

Orders for parts with Lead-Free plating can be placed using the LXXXXXG-XX parts name.

TYPICAL APPLICATION

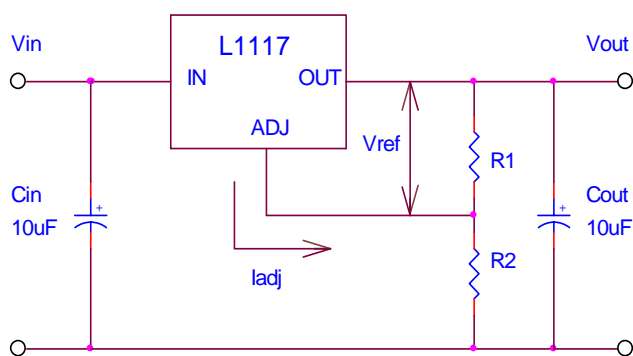

$$V_o = V_{ref} (1 + R_2/R_1) + I_{adj} \times R_2$$

1. Cin needed if device is far from from filter capacitors.
2. Cout required for stability.

- Basic Adjustable Regulator Circuit -

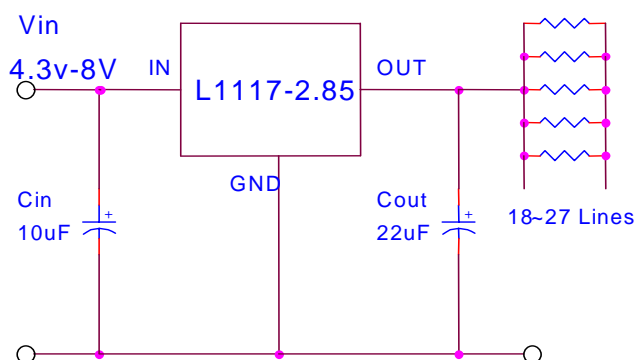

- Active SCSI Bus Terminators -

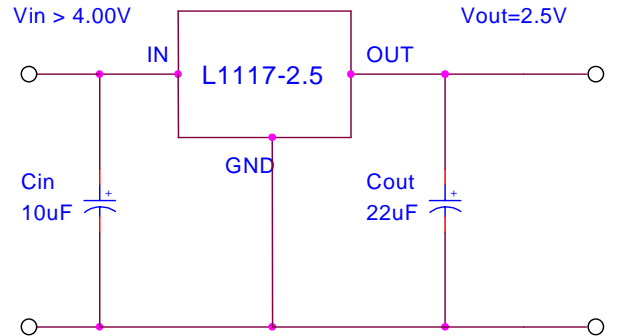
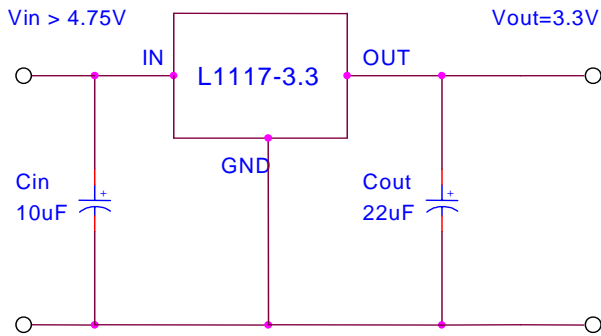

Basic Fixed Output Regulator Circuit

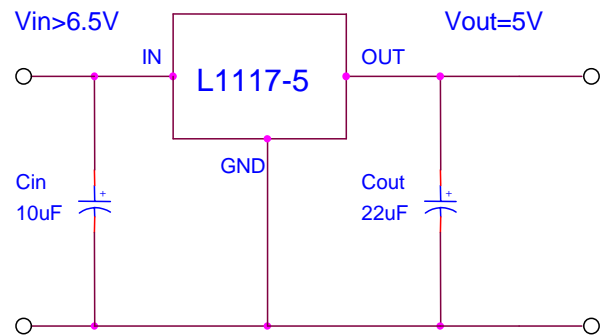

Basic Fixed Output Regulator Circuit

Basic Fixed Output Regulator Circuit

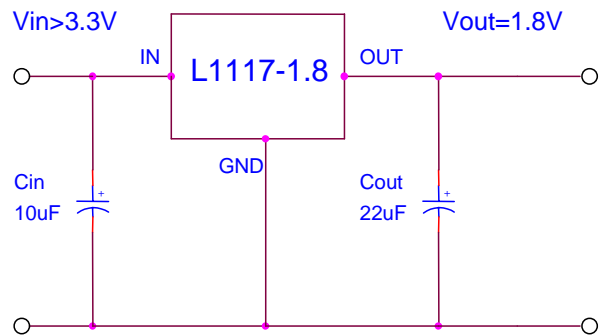

Basic Fixed Output Regulator Circuit

Typical Performance Characteristics

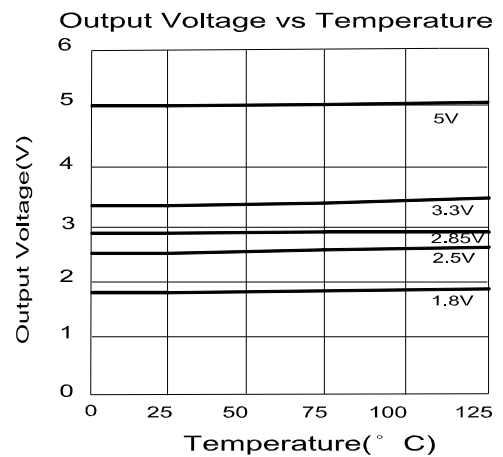
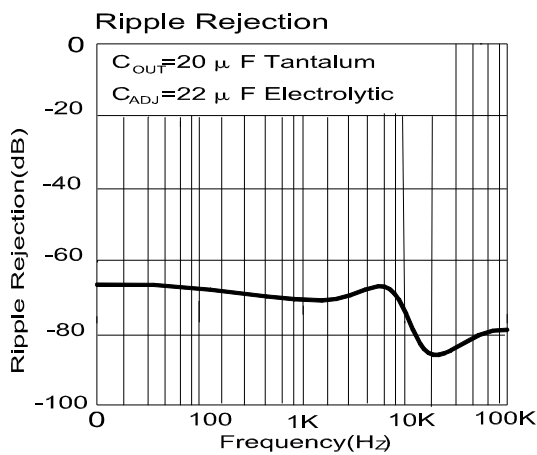
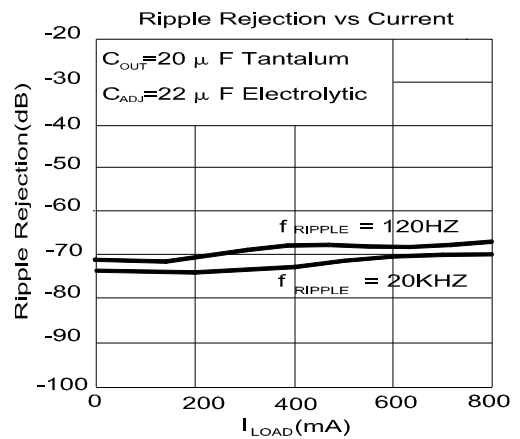
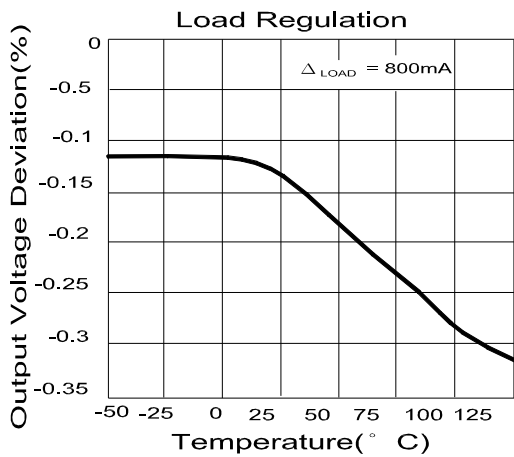
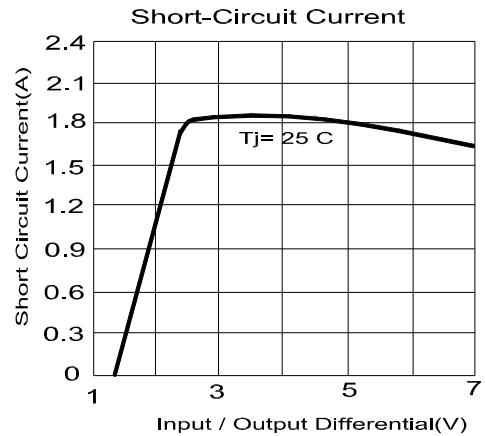
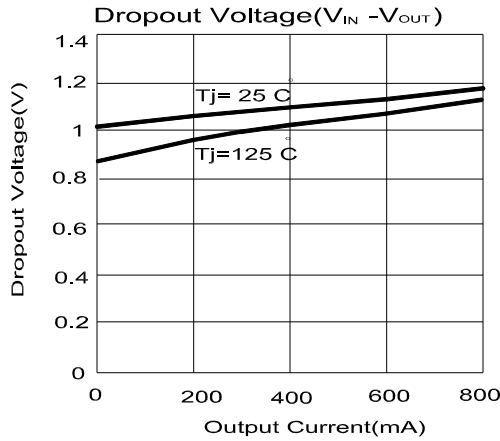

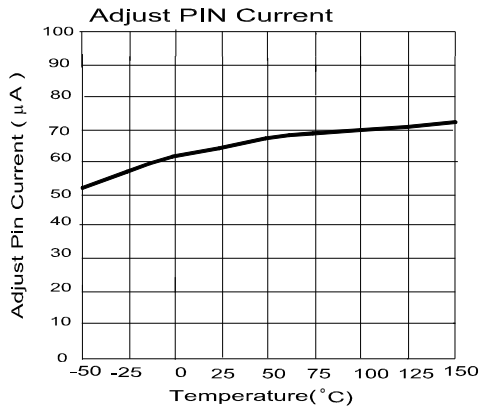

Load Transient

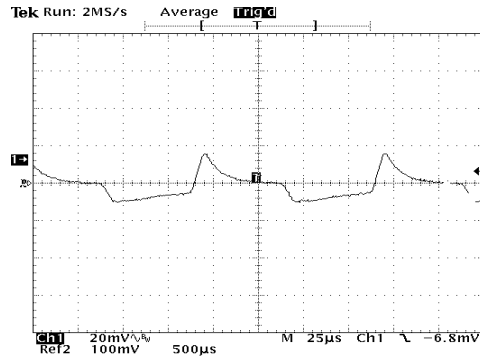

Vout=1.8V, Vin=3.3V, Iout=105mA/800mA
 Cin=10µF, Cout=10µF

Load Transient

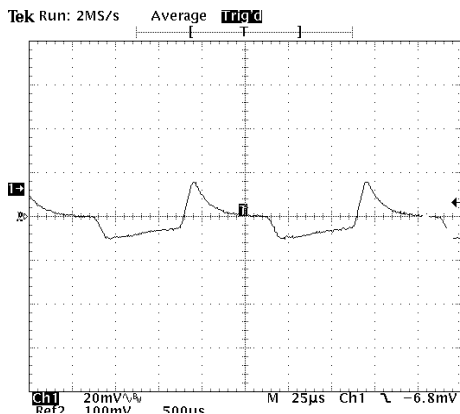

Vout=2.5V, Vin=4V, Iout=105mA/800mA
 Cin=10µF, Cout=10µF

Load Transient

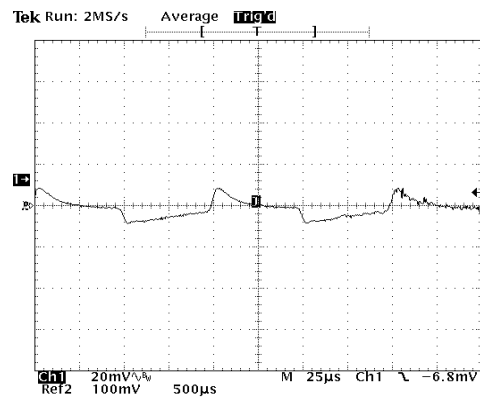

Vout=2.85V, Vin=4.35V, Iout=105mA/800mA
 Cin=10µF, Cout=10µF

Load Transient

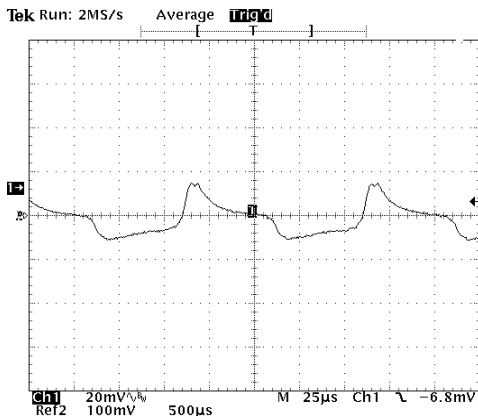

Vout=3.3V, Vin=4.8V, Iout=105mA/800mA
 Cin=10µF, Cout=10µF

Load Transient

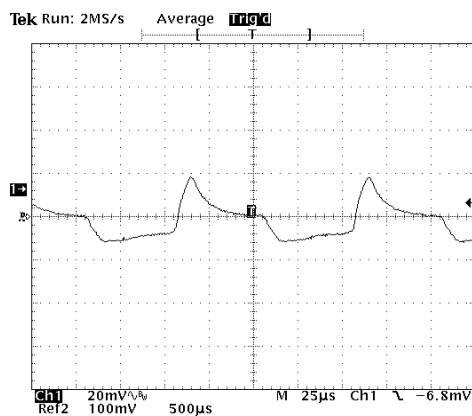

Vout=5V, Vin=6.5V, Iout=105mA/800mA
 Cin=10µF, Cout=10µF

PIN CONFIGURATIONS

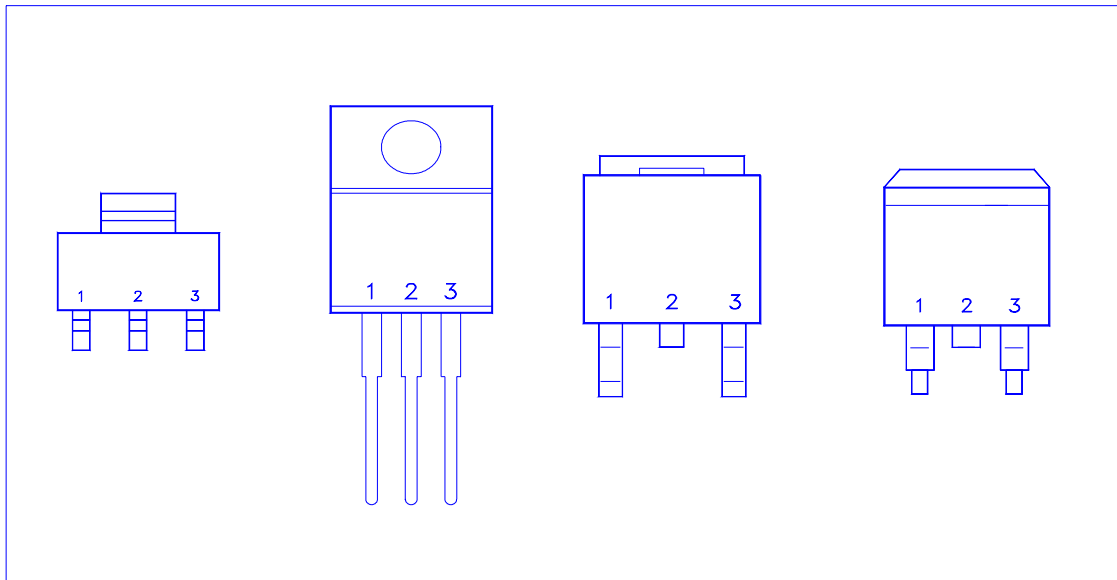

Pin #	Function
1	Adjust/Ground
2	Output
3	Input

Note: TAB is Output Pin

SOT-223 MECHANICAL DATA

Dimension	mm			Dimension	mm		
	Min.	Typ.	Max.		Min.	Typ.	Max.
A	0.67	0.7	0.73	H	3.3	3.5	3.7
B	6.7	7	7.3	I	0.63	0.65	0.67
C	2.9	3	3.1	J		0.32	0.4
D	2.27	2.3	2.33	K	0°		10°
E	4.57	4.6	4.63	L	0.03		0.1
F	1.5	1.6	1.7	M			
G	6.3	6.5	6.7	N			

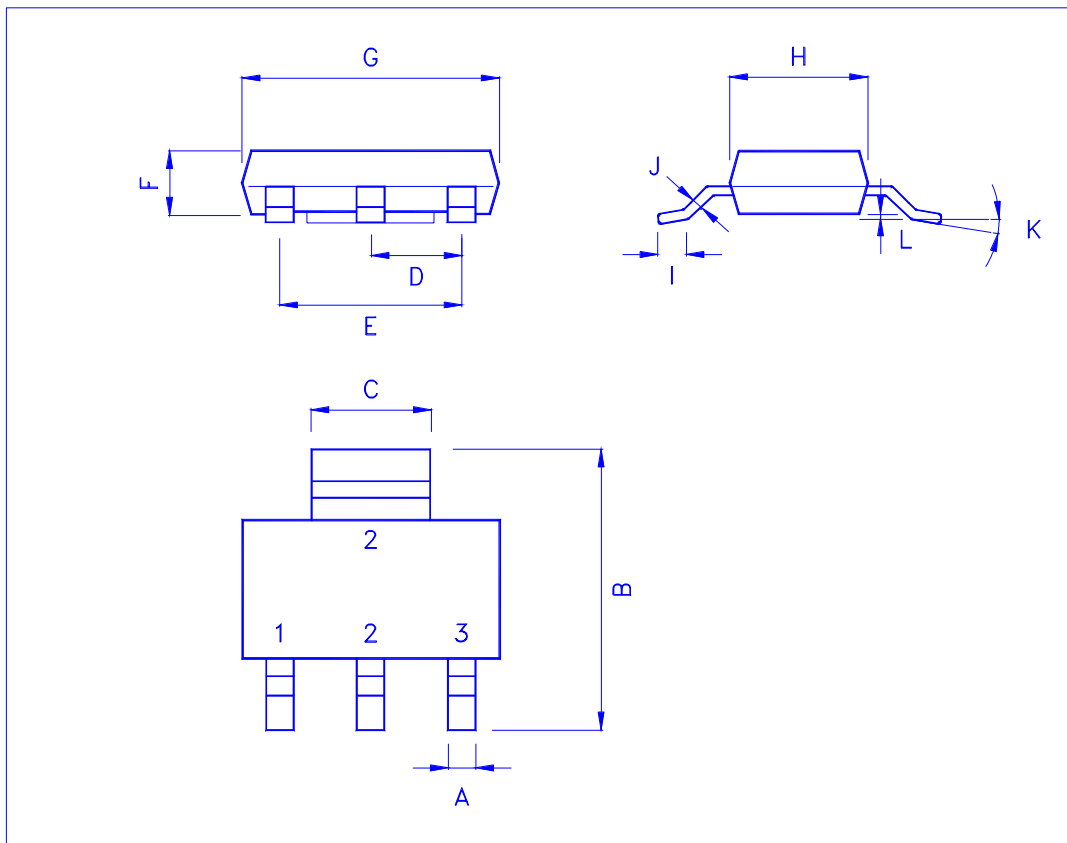

TO-252 (DPAK) MECHANICAL DATA

Dimension	mm			Dimension	mm		
	Min.	Typ.	Max.		Min.	Typ.	Max.
A	9.35		10.1	H		0.8	
B	2.2		2.4	I	6.4		6.6
C	0.48		0.6	J	5.2		5.4
D	0.89		1.5	K	0.6		1
E	0.45		0.6	L	0.64		0.9
F	0.03		0.23	M	4.4		4.6
G	6		6.2	N			

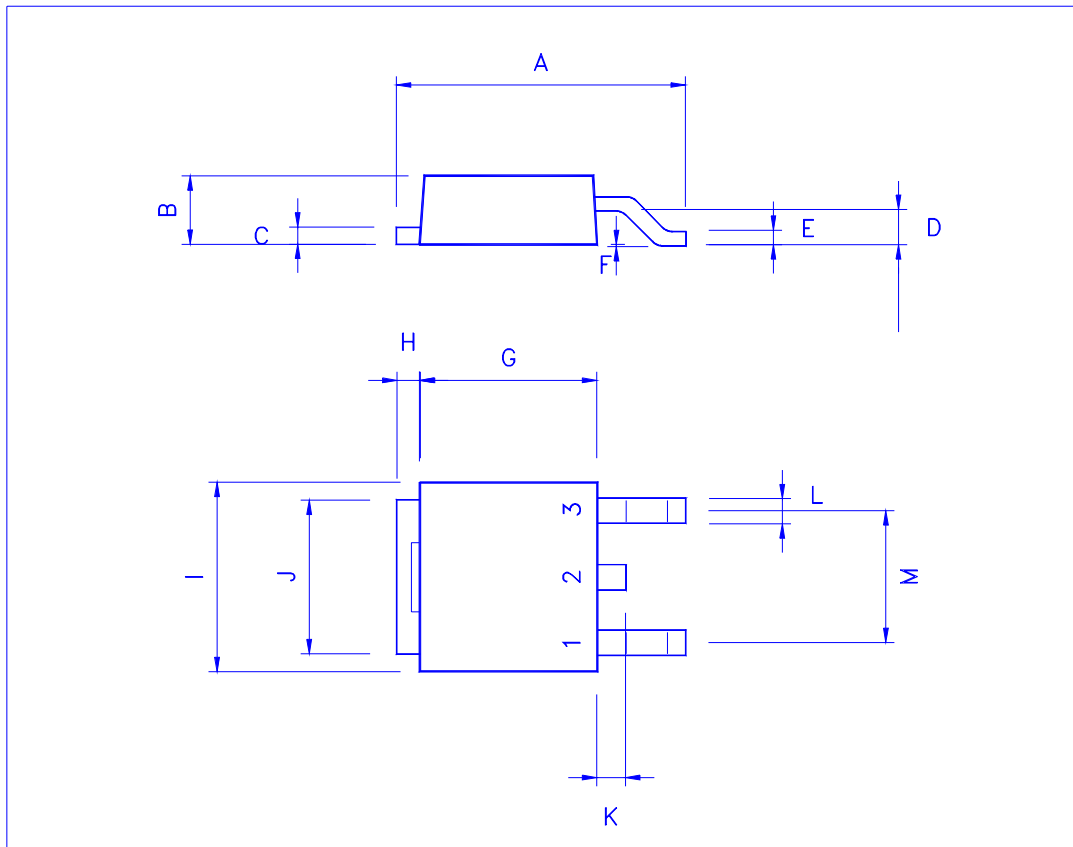

TO-220 (3-Lead) MECHANICAL DATA

Dimension	mm			Dimension	mm		
	Min.	Typ.	Max.		Min.	Typ.	Max.
A	9.78	10.16	10.54	H	2.4	2.54	2.68
B	2.61	2.74	2.87	I	1.19	1.27	1.35
C		20		J	4.4	4.6	4.8
D	28.5	28.9	29.3	K	1.14	1.27	1.4
E	14.6	15.0	15.4	L	2.3	2.6	2.9
F	8.4	8.8	9.2	M	0.26	0.46	0.66
G	0.72	0.8	0.88	N		7°	

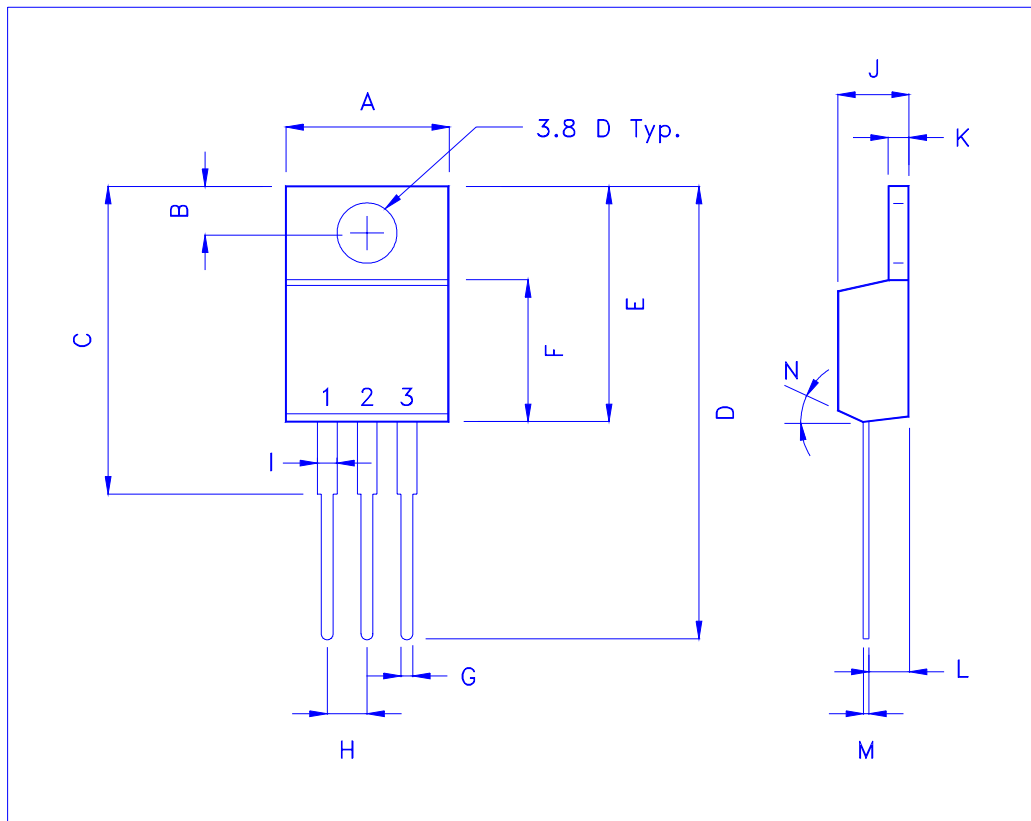

TO-263 (D²PAK) MECHANICAL DATA

Dimension	mm			Dimension	mm		
	Min.	Typ.	Max.		Min.	Typ.	Max.
A	14.5	15	15.8	H	1.0	1.5	1.8
B	4.2		4.7	I	9.8		10.3
C	1.20		1.35	J		6.5	
D		2.8		K		1.5	
E	0.3	0.4	0.5	L	0.7		1.4
F	-0.102		0.203	M	4.83	5.08	5.33
G	8.5	9	9.5	N			

