

High-Voltage, High-Current OPERATIONAL AMPLIFIER

FEATURES

- **WIDE SUPPLY RANGE**
 Single Supply: +8V to +60V
 Dual Supply: $\pm 4V$ to $\pm 30V$
- **HIGH OUTPUT CURRENT:**
 500mA Continuous
- **WIDE OUTPUT VOLTAGE SWING**
- **FULLY PROTECTED:**
 Thermal Shutdown
 Adjustable Current Limit
- **OUTPUT DISABLE CONTROL**
- **THERMAL SHUTDOWN INDICATOR**
- **HIGH SLEW RATE:** 6V/ μs
- **LOW QUIESCENT CURRENT**
- **PACKAGES:**
 7-Lead TO-220, Zip and Straight Leads
 7-Lead DPAK Surface-Mount

APPLICATIONS

- VALVE, ACTUATOR DRIVERS
- SYNCHRO, SERVO DRIVERS
- POWER SUPPLIES
- TEST EQUIPMENT
- TRANSDUCER EXCITATION
- AUDIO AMPLIFIERS

DESCRIPTION

The OPA547 is a low-cost, high-voltage/high-current operational amplifier ideal for driving a wide variety of loads. A laser-trimmed monolithic integrated circuit provides excellent low-level signal accuracy and high output voltage and current.

The OPA547 operates from either single or dual supplies for design flexibility. In single-supply operation, the input common-mode range extends below ground.

The OPA547 is internally protected against over-temperature conditions and current overloads. In addition, the OPA547 was designed to provide an accurate, user-selected current limit. Unlike other designs which use a "power" resistor in series with the output current path, the OPA547 senses the load indirectly. This allows the current limit to be adjusted from 0mA to 750mA with a 0 to 150 μA control signal. This is easily done with a resistor/potentiometer or controlled digitally with a voltage-out or current-out DAC.

The Enable/Status (E/S) pin provides two functions. An input on the pin not only disables the output stage to effectively disconnect the load, but also reduces the quiescent current to conserve power. The E/S pin output can be monitored to determine if the OPA547 is in thermal shutdown.

The OPA547 is available in an industry-standard 7-lead staggered and straight lead TO-220 package, and a 7-lead DPAK surface-mount plastic power package. The copper tab allows easy mounting to a heat sink or circuit board for excellent thermal performance. It is specified for operation over the extended industrial temperature range, $-40^{\circ}C$ to $+85^{\circ}C$.

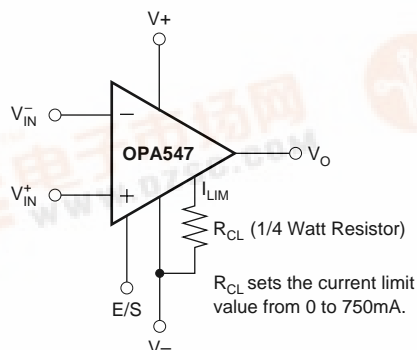

Please be aware that an important notice concerning availability, standard warranty, and use in critical applications of Texas Instruments semiconductor products and disclaimers thereto appears at the end of this data sheet.

ABSOLUTE MAXIMUM RATINGS⁽¹⁾

| | |
|---|----------------------------|
| Output Current | See SOA Curve |
| Supply Voltage, V+ to V- | 60V |
| Input Voltage | (V-) - 0.5V to (V+) + 0.5V |
| Input Shutdown Voltage | V+ |
| Operating Temperature | -40°C to +125°C |
| Storage Temperature | -55°C to +125°C |
| Junction Temperature | 150°C |
| Lead Temperature (soldering 10s) ⁽²⁾ | 300°C |

NOTES: (1) Stresses above these ratings may cause permanent damage. (2) Vapor-phase or IR reflow techniques are recommended for soldering the OPA547F surface-mount package. Wave soldering is not recommended due to excessive thermal shock and "shadowing" of nearby devices.



ELECTROSTATIC DISCHARGE SENSITIVITY

This integrated circuit can be damaged by ESD. Texas Instruments recommends that all integrated circuits be handled with appropriate precautions. Failure to observe proper handling and installation procedures can cause damage.

ESD damage can range from subtle performance degradation to complete device failure. Precision integrated circuits may be more susceptible to damage because very small parametric changes could cause the device not to meet its published specifications.

PACKAGE/ORDERING INFORMATION

For the most current package and ordering information, see the Package Ordering Addendum at the end of this document, or see the TI website at www.ti.com.

PIN CONFIGURATIONS

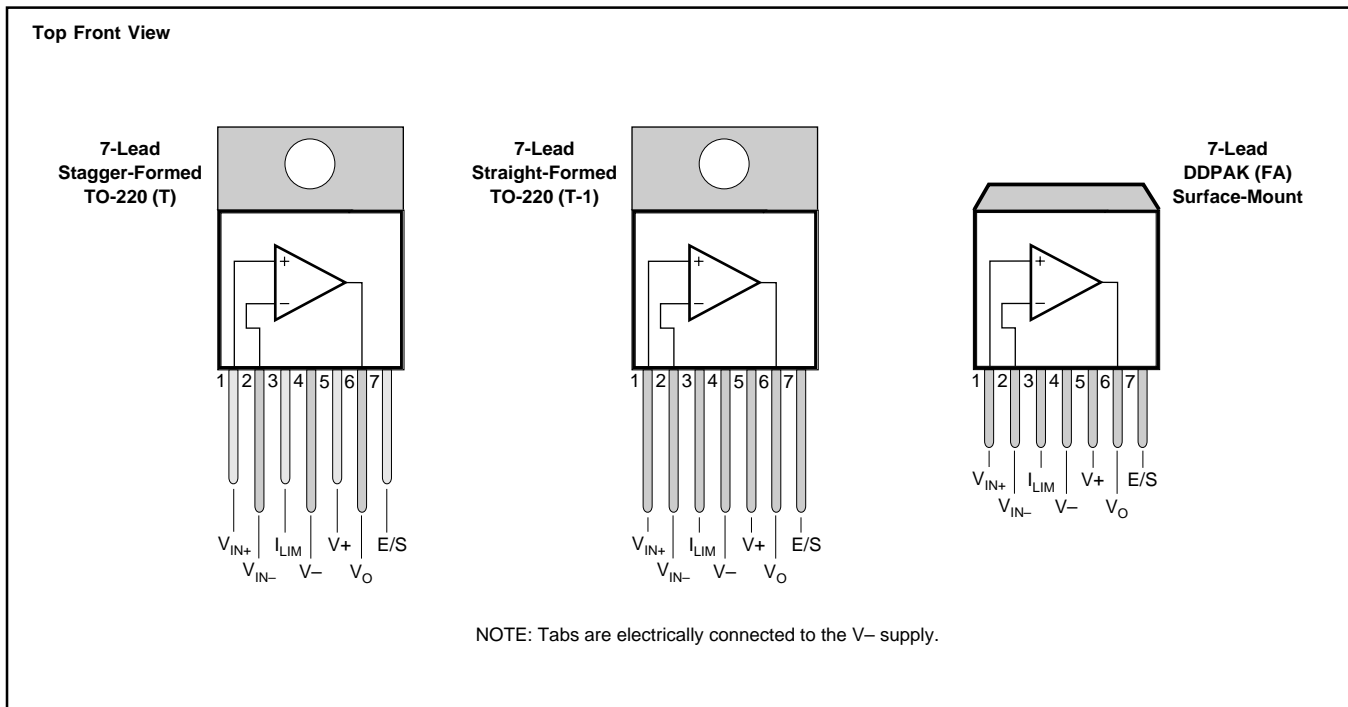

ELECTRICAL CHARACTERISTICS

At T_{CASE} = +25°C, V_S = ±30V and E/S pin open, unless otherwise noted.

| PARAMETER | CONDITION | OPA547T, F | | | UNITS |
|---|---|---|--|--|--|
| | | MIN | TYP | MAX | |
| OFFSET VOLTAGE Input Offset Voltage vs Temperature vs Power Supply | V _{CM} = 0, I _O = 0 T _A = -40°C to +85°C V _S = ±4V to ±30V | | ±1 ±25 10 | ±5 100 | mV μV/°C μV/V |
| INPUT BIAS CURRENT ⁽¹⁾ Input Bias Current ⁽²⁾ vs Temperature Input Offset Current | V _{CM} = 0V V _{CM} = 0V | | -100 ±0.5 ±5 | -500 ±50 | nA nA/°C nA |
| NOISE Input Voltage Noise Density, f = 1kHz Current Noise Density, f = 1kHz | | | 90 200 | | nV/√Hz fA/√Hz |
| INPUT VOLTAGE RANGE Common-Mode Voltage Range: Positive Negative Common-Mode Rejection | Linear Operation Linear Operation V _{CM} = (V-) -0.1V to (V+) -3V | (V+) -3 (V-) -0.1 80 | (V+) -2.3 (V-) -0.2 95 | | V V dB |
| INPUT IMPEDANCE Differential Common-Mode | | | 10 ⁷ 6 10 ⁹ 4 | | Ω pF Ω pF |
| OPEN-LOOP GAIN Open-Loop Voltage Gain, f = 10Hz | V _O = ±25V, R _L = 1kΩ V _O = ±25V, R _L = 50Ω | 100 | 115 110 | | dB dB |
| FREQUENCY RESPONSE Gain-Bandwidth Product Slew Rate Full-Power Bandwidth Settling Time: ±0.1% Total Harmonic Distortion + Noise, f = 1kHz | R _L = 50Ω G = 1, 50V _{PP} , R _L = 50Ω G = -10, 50V Step R _L = 50Ω, G = +3V, 1W Power | | 1 6 See Typical Curve 18 0.004 ⁽³⁾ | | MHz V/μs kHz μs % |
| OUTPUT Voltage Output, Positive Negative Positive Negative Maximum Continuous Current Output: dc ac Leakage Current, Output Disabled, dc Output Current Limit Current Limit Range Current Limit Equation Current Limit Tolerance ⁽¹⁾ Capacitive Load Drive | I _O = 0.5A I _O = -0.5A I _O = 0.1A I _O = -0.1A R _{CL} = 31.6kΩ (I _{LIM} = ±375mA), R _L = 50Ω | (V+) -2.2 (V-) +1.6 (V+) -1.8 (V-) +1.2 ±500 500 | (V+) -1.9 (V-) +1.3 (V+) -1.5 (V-) +0.8 See Typical Curve 0 to ±750 I _{LIM} = (5000)(4.75)/(31600Ω + R _{CL}) ±10 | ±30 | V V V V mA mArms mA A mA |
| OUTPUT ENABLE /STATUS (E/S) PIN Shutdown Input Mode V _{E/S} HIGH (output enabled) V _{E/S} LOW (output disabled) I _{E/S} HIGH (output enabled) I _{E/S} LOW (output disabled) Output Disable Time Output Enable Time Thermal Shutdown Status Output Normal Operation Thermally Shutdown Junction Temperature, Shutdown Reset from Shutdown | E/S Pin Open or Forced HIGH E/S Pin Forced LOW E/S Pin HIGH E/S Pin LOW Sourcing 20μA Sinking 5μA, T _J > 160°C | (V-) +2.4 (V-) +2.4 | -60 -65 1 3 (V-) +3.5 (V-) +0.35 +160 +140 | (V-) +0.8 (V-) +0.8 | V V μA μA μs μs V V °C °C |
| POWER SUPPLY Specified Voltage Operating Voltage Range Quiescent Current Quiescent Current, Shutdown Mode | I _{LIM} Connected to V-, I _O = 0 I _{LIM} Connected to V- | ±4 | ±30 ±10 ±4 | ±30 ±15 | V V mA mA |
| TEMPERATURE RANGE Specified Range Operating Range Storage Range Thermal Resistance, θ _{JC} 7-Lead DDPAK, 7-Lead TO-220 7-Lead DDPAK, 7-Lead TO-220 Thermal Resistance, θ _{JA} 7-Lead DDPAK, 7-Lead TO-220 | f > 50Hz dc No Heat Sink | -40 -40 -55 | 2 3 65 | +85 +125 +125 | °C °C °C °C/W °C/W °C/W |

NOTES: (1) High-speed test at T_J = +25°C. (2) Positive conventional current flows into the input terminals. (3) See *Total Harmonic Distortion+Noise* in the Typical Characteristics section for additional power levels. (4) See *Small-Signal Overshoot vs Load Capacitance* in the Typical Characteristics section.

TYPICAL CHARACTERISTICS

At $T_{CASE} = +25^{\circ}C$, $V_S = \pm 30V$, and E/S pin open, unless otherwise noted.

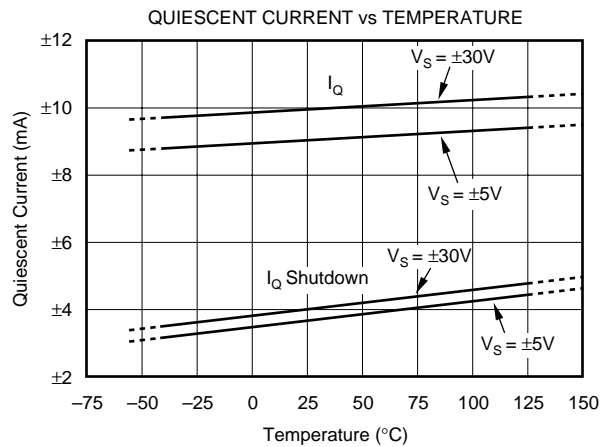
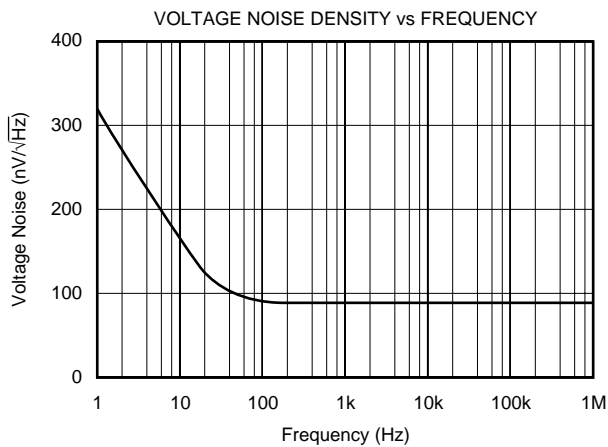
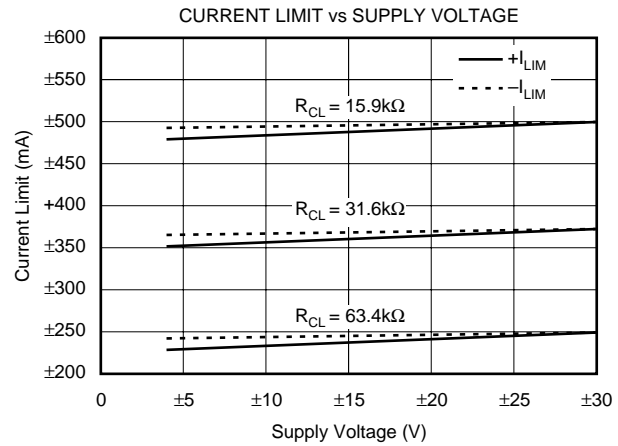
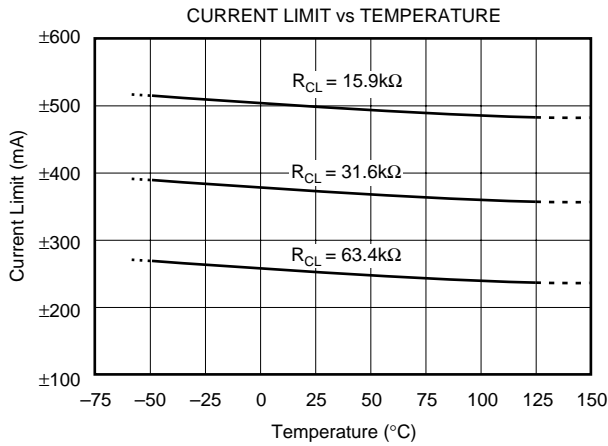
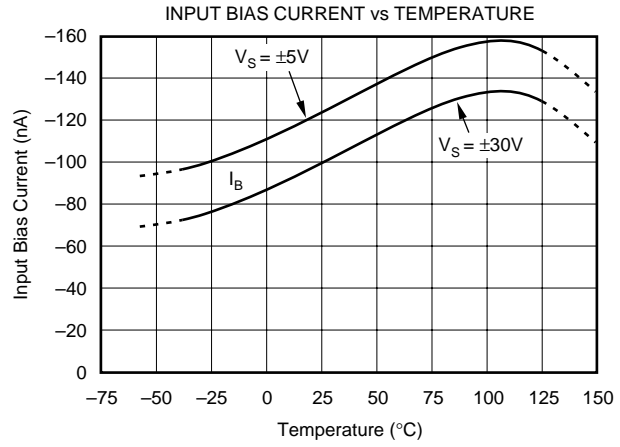
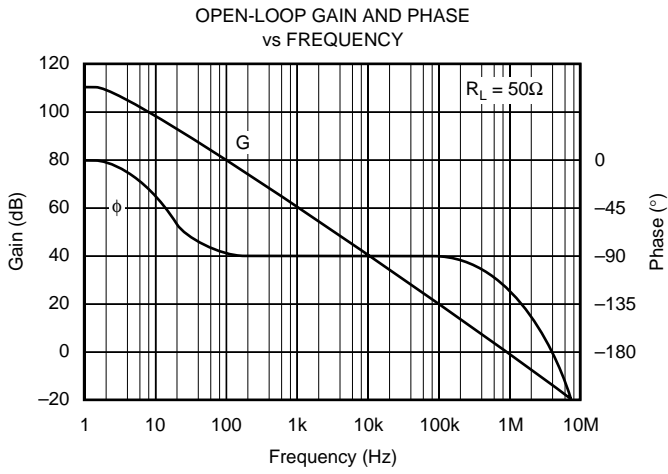

TYPICAL CHARACTERISTICS (Cont.)

At $T_{CASE} = +25^{\circ}C$, $V_S = \pm 30V$, and E/S pin open, unless otherwise noted.

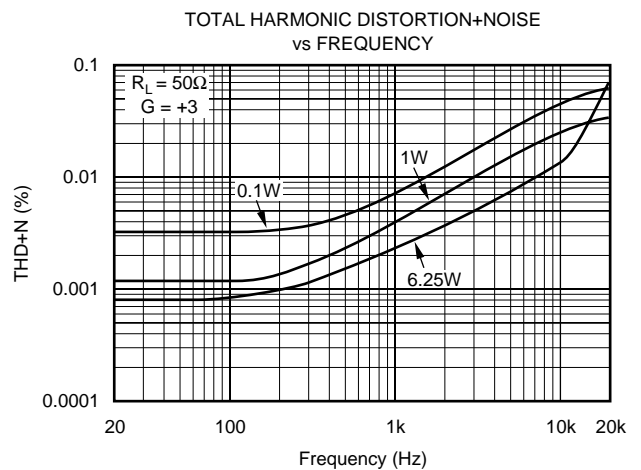
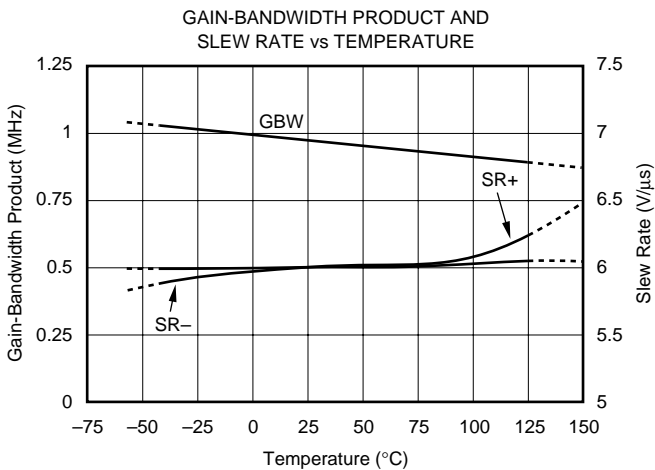
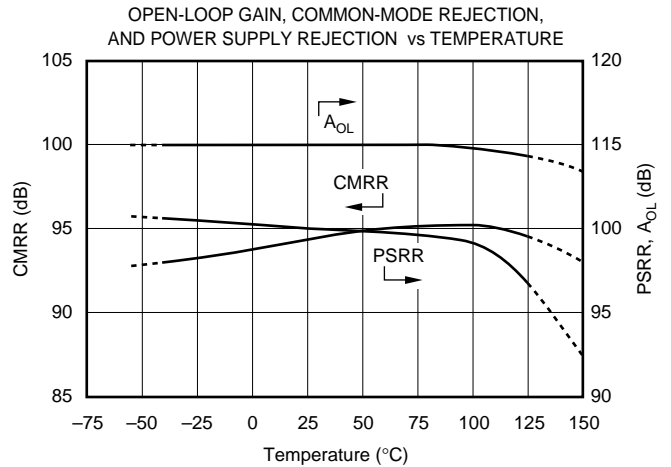
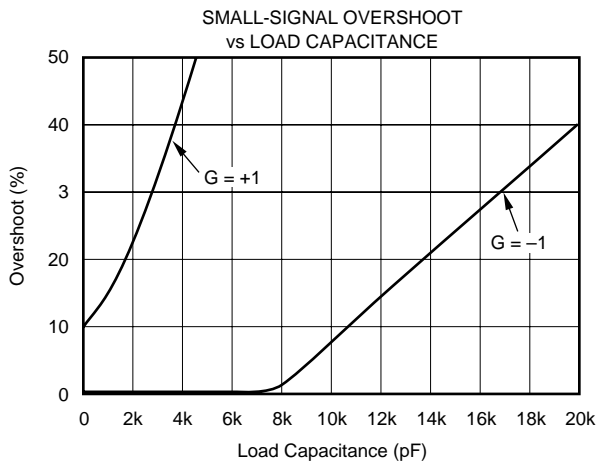
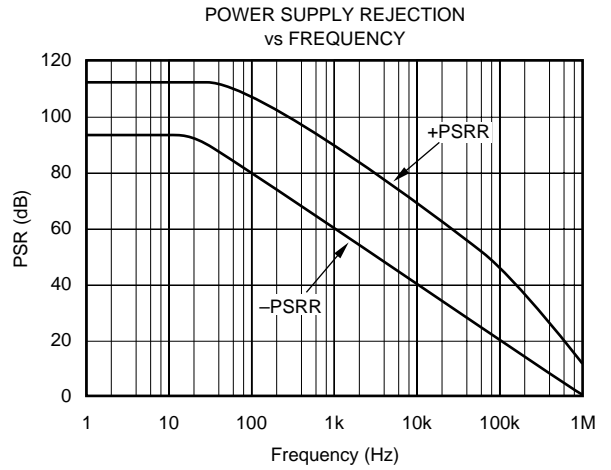
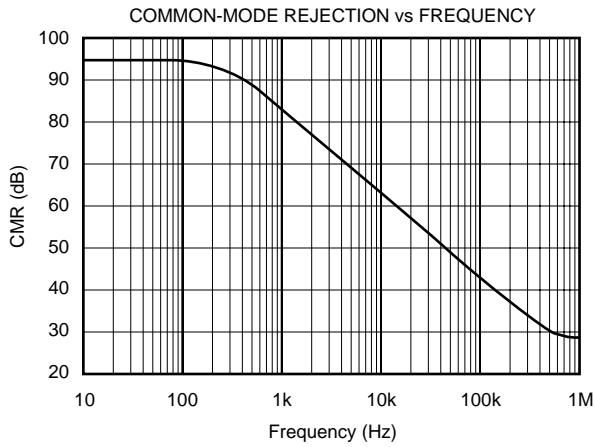

TYPICAL CHARACTERISTICS (Cont.)

At $T_{CASE} = +25^{\circ}C$, $V_S = \pm 30V$, and E/S pin open, unless otherwise noted.

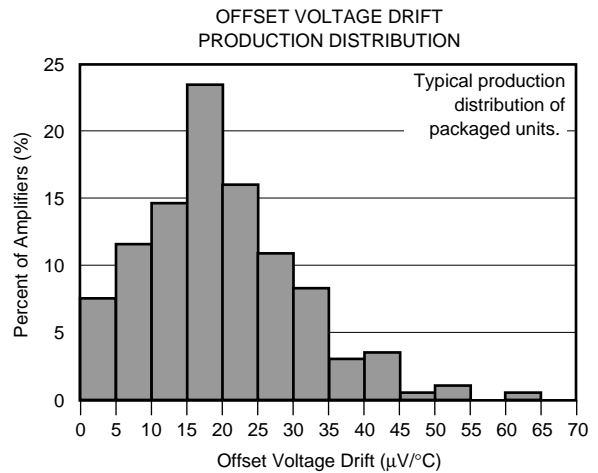
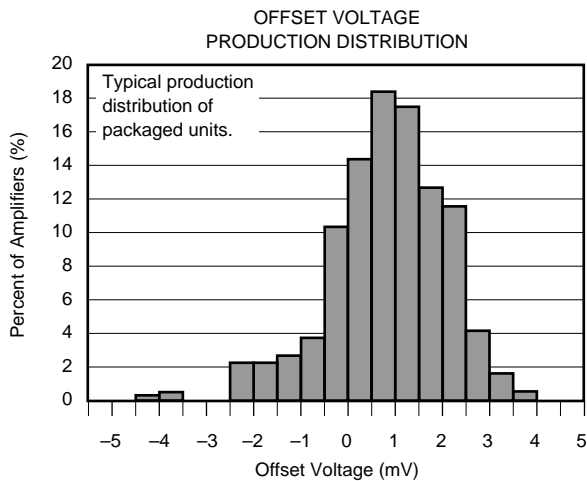
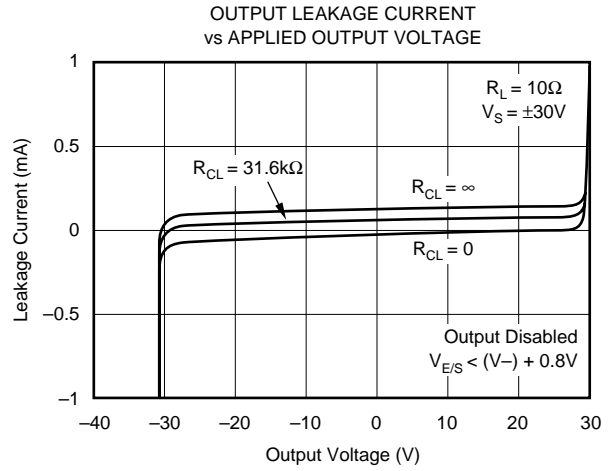
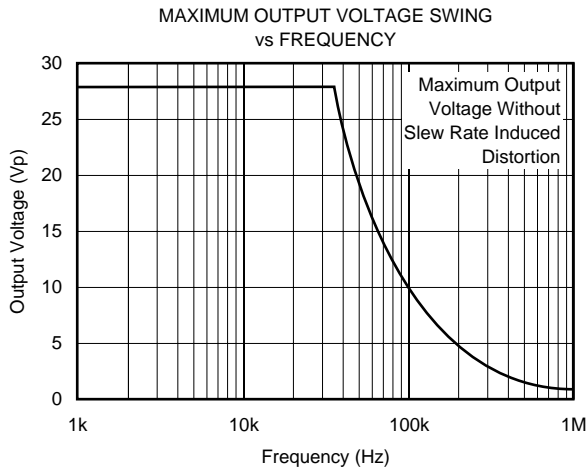
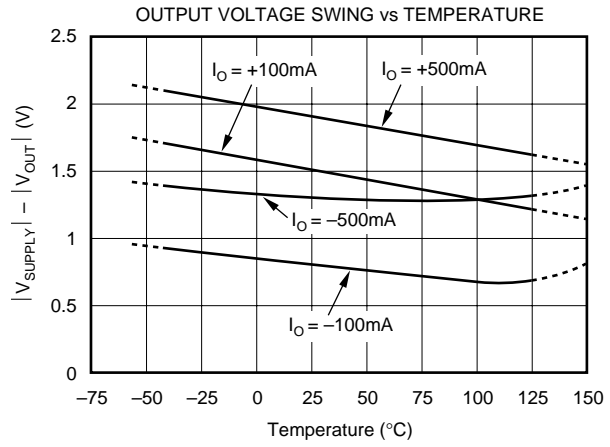
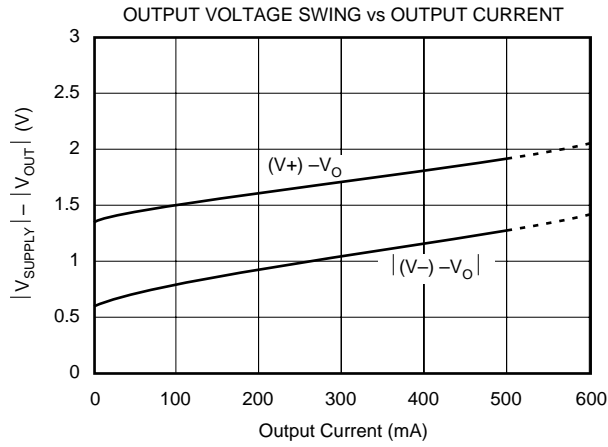

TYPICAL CHARACTERISTICS (Cont.)

At $T_{CASE} = +25^{\circ}C$, $V_S = \pm 35V$, and E/S pin open, unless otherwise noted.

SMALL SIGNAL STEP RESPONSE
 $G = 1$, $C_L = 1000pF$

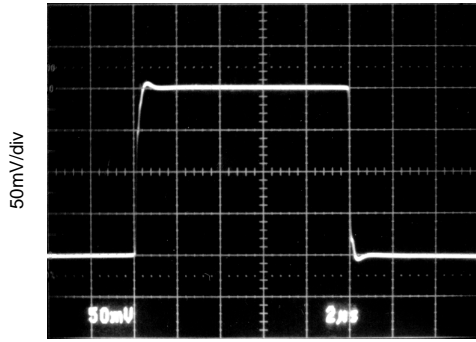

2µs/div

SMALL SIGNAL STEP RESPONSE
 $G = 3$, $C_L = 1000pF$

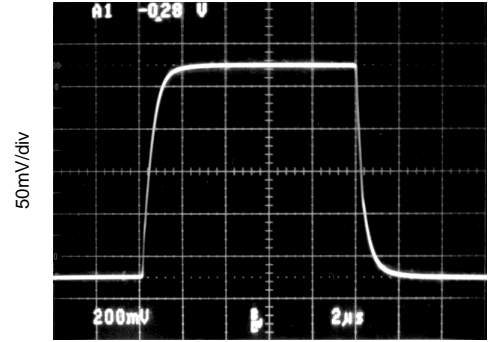

2µs/div

LARGE SIGNAL STEP RESPONSE
 $G = 3$, $C_L = 100pF$, $R_L = 50\Omega$

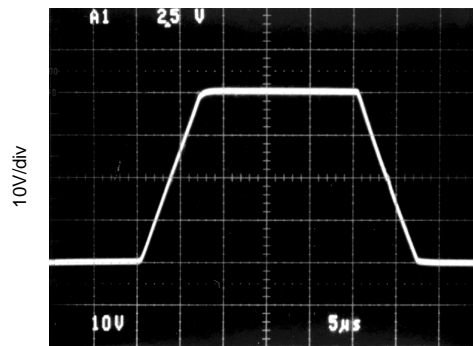

5µs/div

APPLICATIONS INFORMATION

Figure 1 shows the OPA547 connected as a basic noninverting amplifier. The OPA547 can be used in virtually any op amp configuration.

Power-supply terminals should be bypassed with low series impedance capacitors. The technique shown, using a ceramic and tantalum type in parallel, is recommended. Power-supply wiring should have low series impedance.

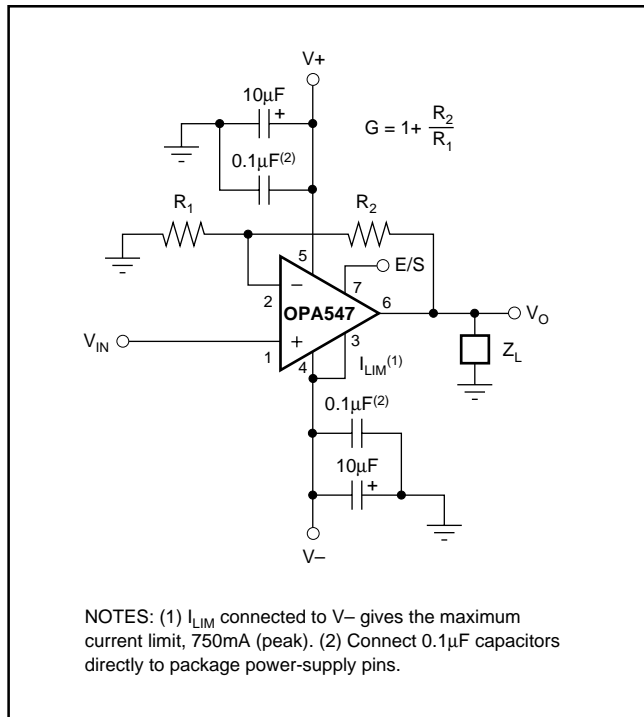

FIGURE 1. Basic Circuit Connections.

POWER SUPPLIES

The OPA547 operates from single (+8V to +60V) or dual ($\pm 4V$ to $\pm 30V$) supplies with excellent performance. Most behavior remains unchanged throughout the full operating voltage range. Parameters which vary significantly with operating voltage are shown in the typical characteristic curves.

Some applications do not require equal positive and negative output voltage swing. Power-supply voltages do not need to be equal. The OPA547 can operate with as little as 8V between the supplies and with up to 60V between the supplies. For example, the positive supply could be set to 55V with the negative supply at -5V, or vice-versa.

ADJUSTABLE CURRENT LIMIT

The OPA547 features an accurate, user-selected current limit. Current limit is set from 0mA to 750mA by controlling the input to the I_{LIM} pin. Unlike other designs which use a power resistor in series with the output current path, the OPA547 senses the load indirectly. This allows the current limit to be set with a 0µA to 150µA control signal. In contrast, other designs require a limiting resistor to handle the full output current (750mA in this case).

With the OPA547, the simplest method for adjusting the current limit uses a resistor or potentiometer connected between the I_{LIM} pin and $V-$ according to the Equation 1:

$$R_{CL} = \frac{(5000)(4.75)}{I_{LIM}} - 31.6k\Omega \quad (1)$$

The low-level control signal (0µA to 150µA) also allows the current limit to be digitally controlled with a current-out or voltage-out DAC reference to $V-$ according to the equations given in Figure 3.

Figure 3 shows a simplified schematic of the internal circuitry used to set the current limit. Leaving the I_{LIM} pin open programs the output current to zero, while connecting I_{LIM} directly to $V-$ programs the maximum output current limit, typically 750mA.

SAFE OPERATING AREA

Stress on the output transistors is determined both by the output current and by the output voltage across the conducting output transistor, $V_S - V_O$. The power dissipated by the output transistor is equal to the product of the output current and the voltage across the conducting transistor, $V_S - V_O$. The Safe Operating Area (SOA curve, Figure 2) shows the permissible range of voltage and current.

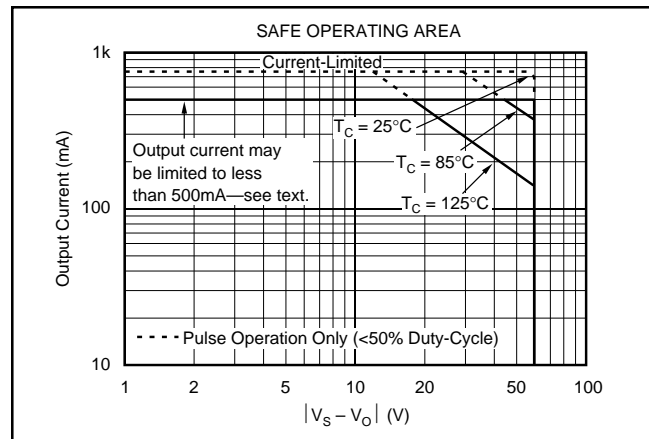

FIGURE 2. Safe Operating Area.

The safe output current decreases as $V_S - V_O$ increases. Output short-circuits are a very demanding case for SOA. A short-circuit to ground forces the full power-supply voltage ($V+$ or $V-$) across the conducting transistor. With $T_C = 25^\circ C$ the maximum output current of 500mA can be achieved under most conditions. Increasing the case temperature reduces the safe output current that can be tolerated without activating the thermal shutdown circuit of the OPA547. For further insight on SOA, consult Application Bulletin SBOA022.

POWER DISSIPATION

Power dissipation depends on power supply, signal, and load conditions. For dc signals, power dissipation is equal to the product of output current times the voltage across the con-

ducting output transistor. Power dissipation can be minimized by using the lowest possible power-supply voltage necessary to assure the required output voltage swing.

For resistive loads, the maximum power dissipation occurs at a dc output voltage of one-half the power-supply voltage. Dissipation with ac signals is lower. Application Bulletin SBOA022 explains how to calculate or measure power dissipation with unusual signals and loads.

HEAT SINKING

Most applications require a heat sink to assure that the maximum junction temperature (150°C) is not exceeded. The heat sink required depends on the power dissipated and on

ambient conditions. Consult Application Bulletin SBOA021 for information on determining heat sink requirements. The internal protection circuitry was designed to protect against overload conditions. It does not activate until the junction temperature reaches approximately 160°C and was not intended to replace proper heat sinking. Continuously running the OPA547 into thermal shutdown will degrade reliability.

The tab of the DDPACK surface-mount version should be soldered to a circuit board copper area for good heat dissipation. Figure 4 shows typical thermal resistance from junction to ambient as a function of the copper area.

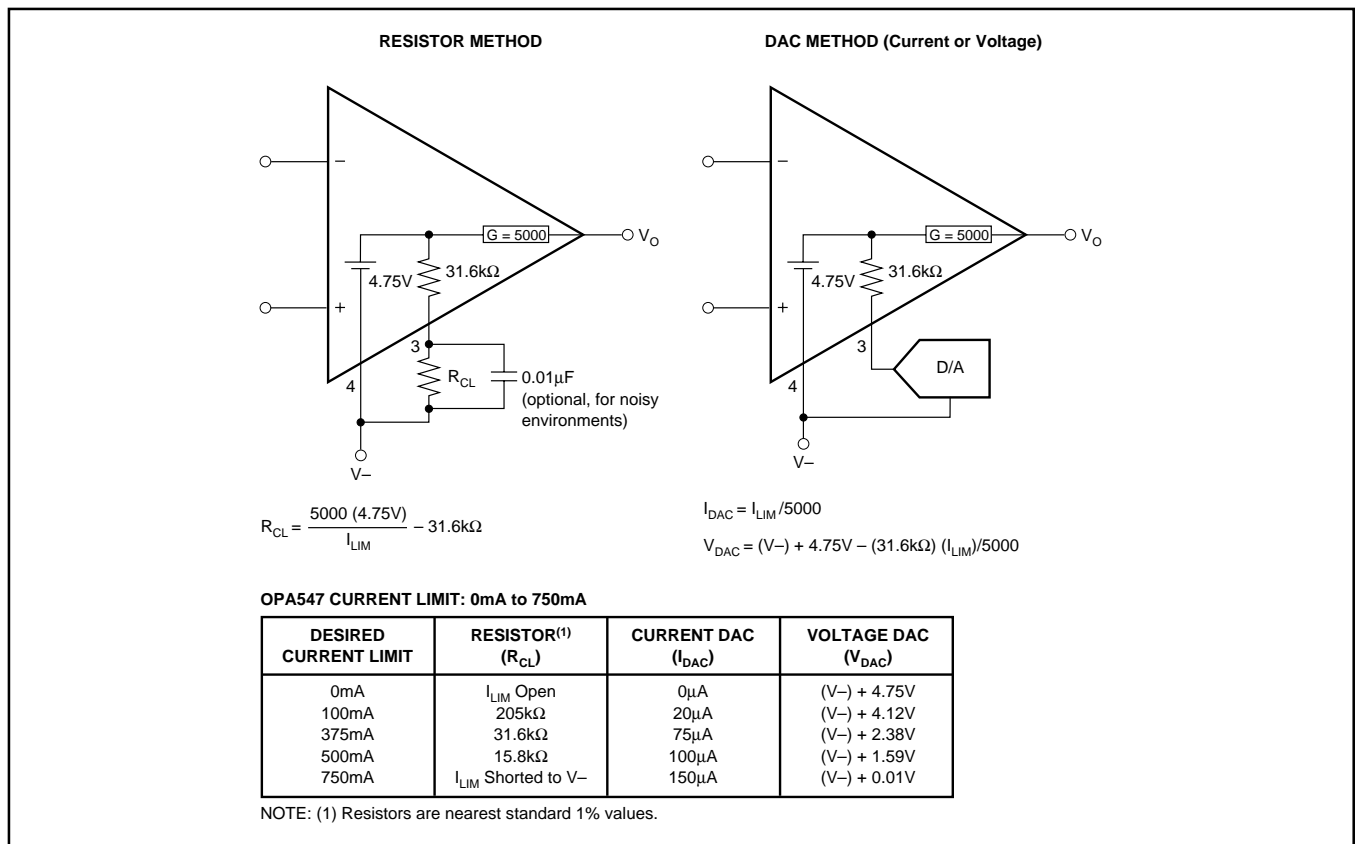

FIGURE 3. Adjustable Current Limit.

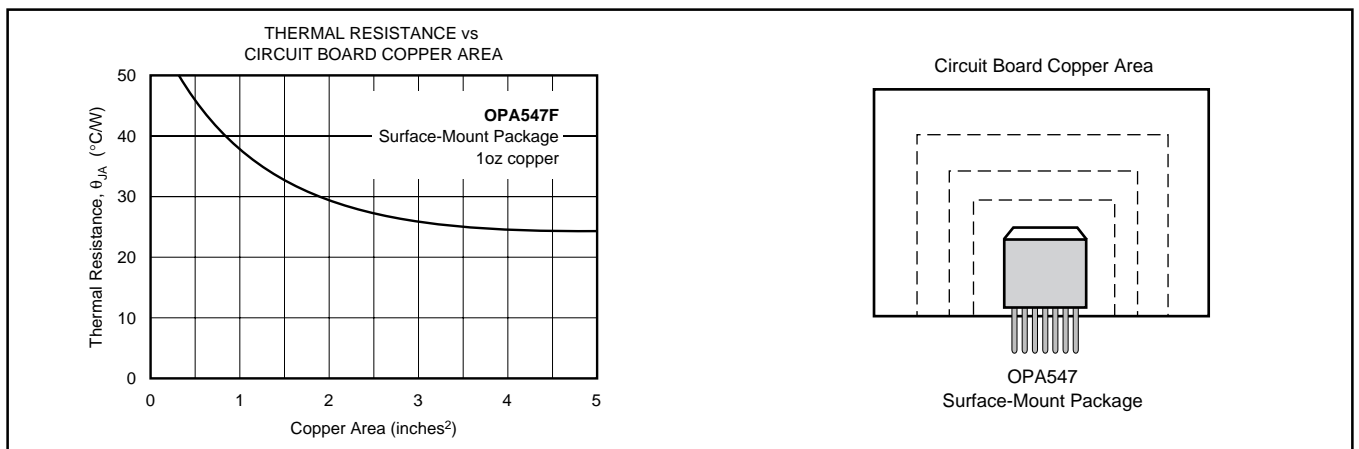

FIGURE 4. Thermal Resistance versus Circuit Board Copper Area.

THERMAL PROTECTION

The OPA547 has thermal shutdown that protects the amplifier from damage. Activation of the thermal shutdown circuit during normal operation is an indication of excessive power dissipation or an inadequate heat sink. Depending on load and signal conditions, the thermal protection circuit may cycle on and off. This limits the dissipation of the amplifier but may have an undesirable effect on the load.

The thermal protection activates at a junction temperature of approximately 160°C. However, for reliable operation, junction temperature should be limited to 150°C. To estimate the margin of safety in a complete design (including heat sink), increase the ambient temperature until the thermal protection is activated. Use worst-case load and signal conditions. For good reliability, the thermal protection should trigger more than 35°C above the maximum expected ambient condition of the application. This produces a junction temperature of 125°C at the maximum expected ambient condition.

ENABLE/STATUS (E/S) PIN

The Enable/Status pin provides two functions: forcing this pin low disables the output stage, or E/S can be monitored to determine if the OPA547 is in thermal shutdown. One or both of these functions can be utilized on the same device using single or dual supplies. For normal operation (output enabled), the E/S pin can be left open or pulled high (at least +2.4V above the negative rail).

Output Disable

A unique feature of the OPA547 is its output disable capability. This function not only conserves power during idle periods (quiescent current drops to approximately 4mA), but also allows multiplexing in low frequency ($f < 10\text{kHz}$), multichannel applications. Signals that are greater than 10kHz may cause leakage current to increase in devices that are shutdown. Figure 15 shows the two OPA547s in a switched amplifier configuration. The on/off state of the two amplifiers is controlled by the voltage on the E/S pin.

To disable the output, the E/S pin is pulled low, no greater than 0.8V above the negative rail. Typically the output is shutdown in 1 μs . Figure 5 provides an example of how to implement this function using a single supply. Figure 6 gives a circuit for dual-supply applications. To return the output to an enabled state, the E/S pin should be disconnected (open) or pulled to at least $(V-) + 2.4\text{V}$. It should be noted that pulling the E/S pin high (output enabled) does not disable internal thermal shutdown.

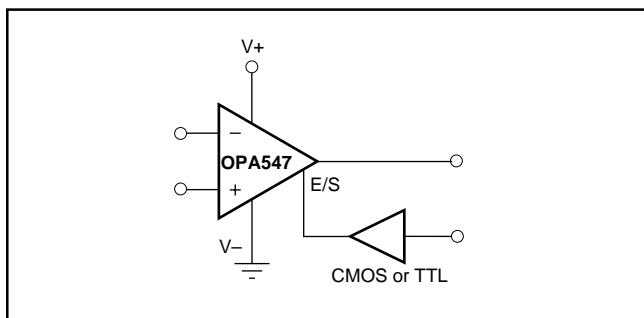

FIGURE 5. Output Disable with a Single Supply.

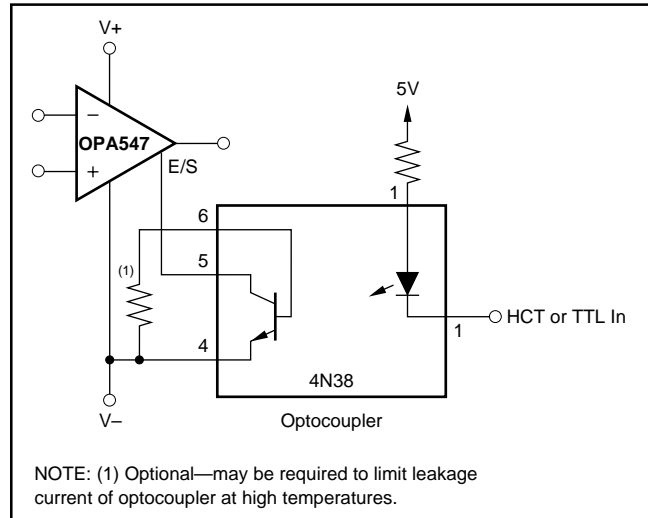

FIGURE 6. Output Disable with Dual Supplies.

Thermal Shutdown Status

Internal thermal shutdown circuitry shuts down the output when the die temperature reaches approximately 160°C, resetting when the die has cooled to 140°C. The E/S pin can be monitored to determine if shutdown has occurred. During normal operation the voltage on the E/S pin is typically 3.5V above the negative rail. Once shutdown has occurred this voltage drops to approximately 350mV above the negative rail.

Figure 7 gives an example of monitoring shutdown in a single-supply application. Figure 8 provides a circuit for dual supplies. External logic circuitry or an LED could be used to indicate if the output has been thermally shutdown, see Figure 13.

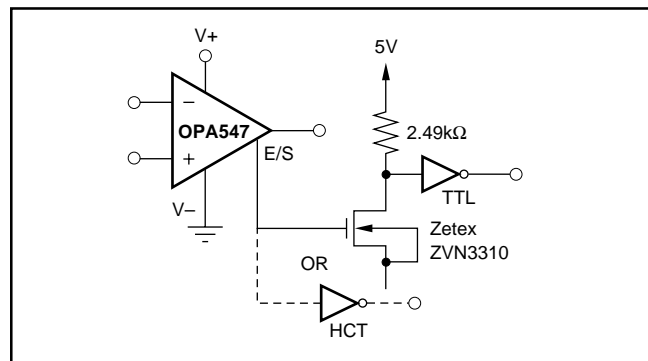

FIGURE 7. Thermal Shutdown Status with a Single Supply.

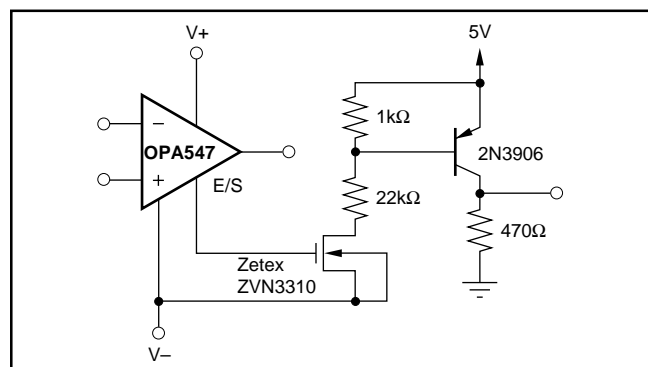

FIGURE 8. Thermal Shutdown Status with Dual Supplies.

Output Disable and Thermal Shutdown Status

As mentioned earlier, the OPA547's output can be disabled and the disable status can be monitored simultaneously. Figures 9 and 10 provide examples using a single supply and dual supplies, respectively.

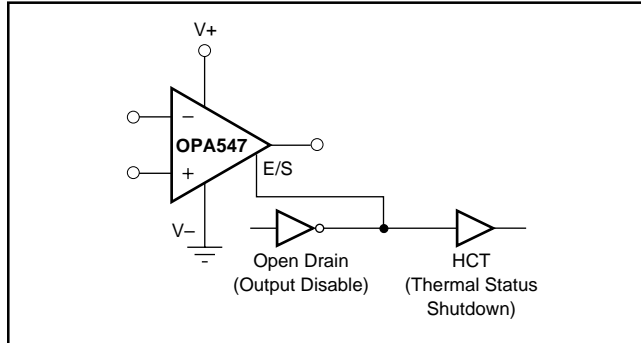

FIGURE 9. Output Disable and Thermal Shutdown Status with a Single Supply.

OUTPUT STAGE COMPENSATION

The complex load impedances common in power op amp applications can cause output stage instability. For normal operation output compensation circuitry is not typically required. However, if the OPA547 is intended to be driven into current limit, a R/C network may be required. Figure 11 shows an output series R/C compensation (snubber) network (3Ω in series with $0.01\mu\text{F}$) which generally provides excellent stability. Some variations in circuit values may be required with certain loads.

OUTPUT PROTECTION

Reactive and EMF-generating loads can return load current to the amplifier, causing the output voltage to exceed the power-supply voltage. This damaging condition can be avoided with clamp diodes from the output terminal to the power supplies, as shown in Figure 11. Schottky rectifier diodes with a 1A or greater continuous rating are recommended.

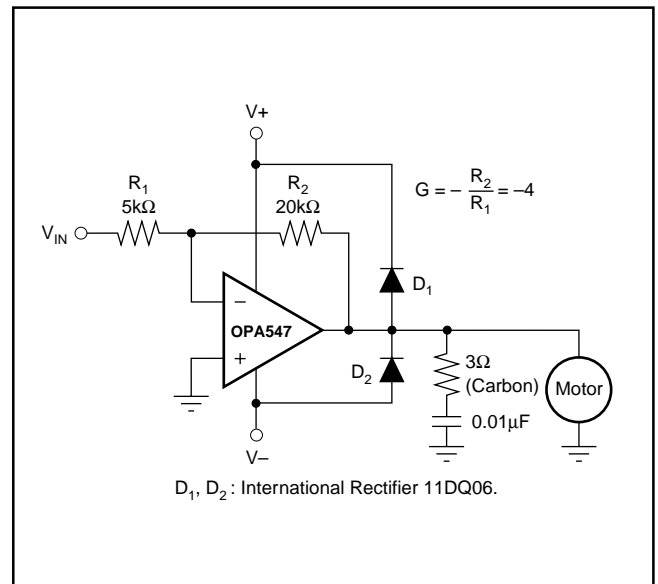

FIGURE 11. Motor Drive Circuit.

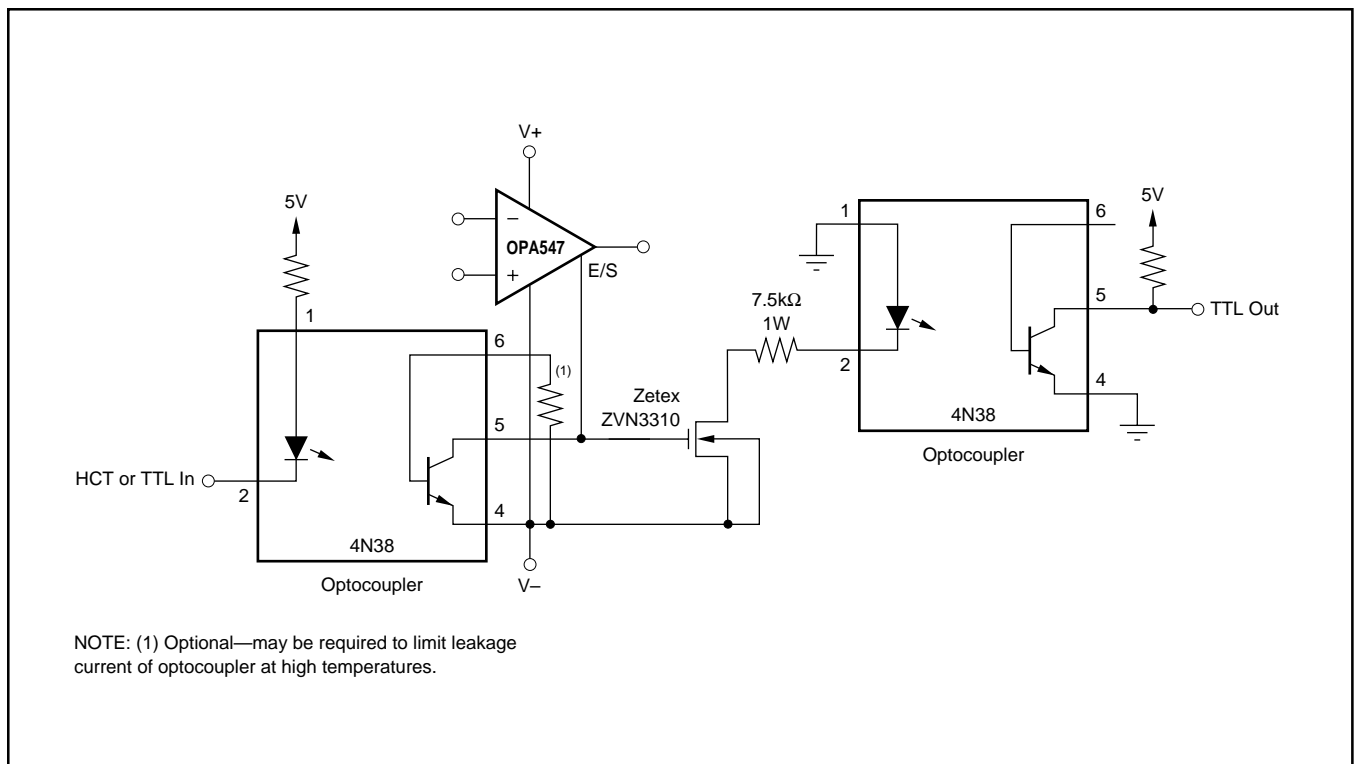

FIGURE 10. Output Disable and Thermal Shutdown Status with Dual Supplies.

VOLTAGE SOURCE APPLICATION

Figure 12 illustrates how to use the OPA547 to provide an accurate voltage source with only three external resistors. First, the current limit resistor, R_{CL} , is chosen according to the desired output current. The resulting voltage at the I_{LIM} pin is constant and stable over temperature. This voltage, V_{CL} , is connected to the noninverting input of the op amp and used as a voltage reference, thus eliminating the need for an external reference. The feedback resistors are selected to gain V_{CL} to the desired output voltage level.

PROGRAMMABLE POWER SUPPLY

A programmable power supply can easily be built using the OPA547. Both the output voltage and output current are user-controlled. Figure 13 shows a circuit using potentiometers to adjust the output voltage and current while Figure 14 uses DACs. An LED tied to the E/S pin through a logic gate indicates if the OPA547 is in thermal shutdown.

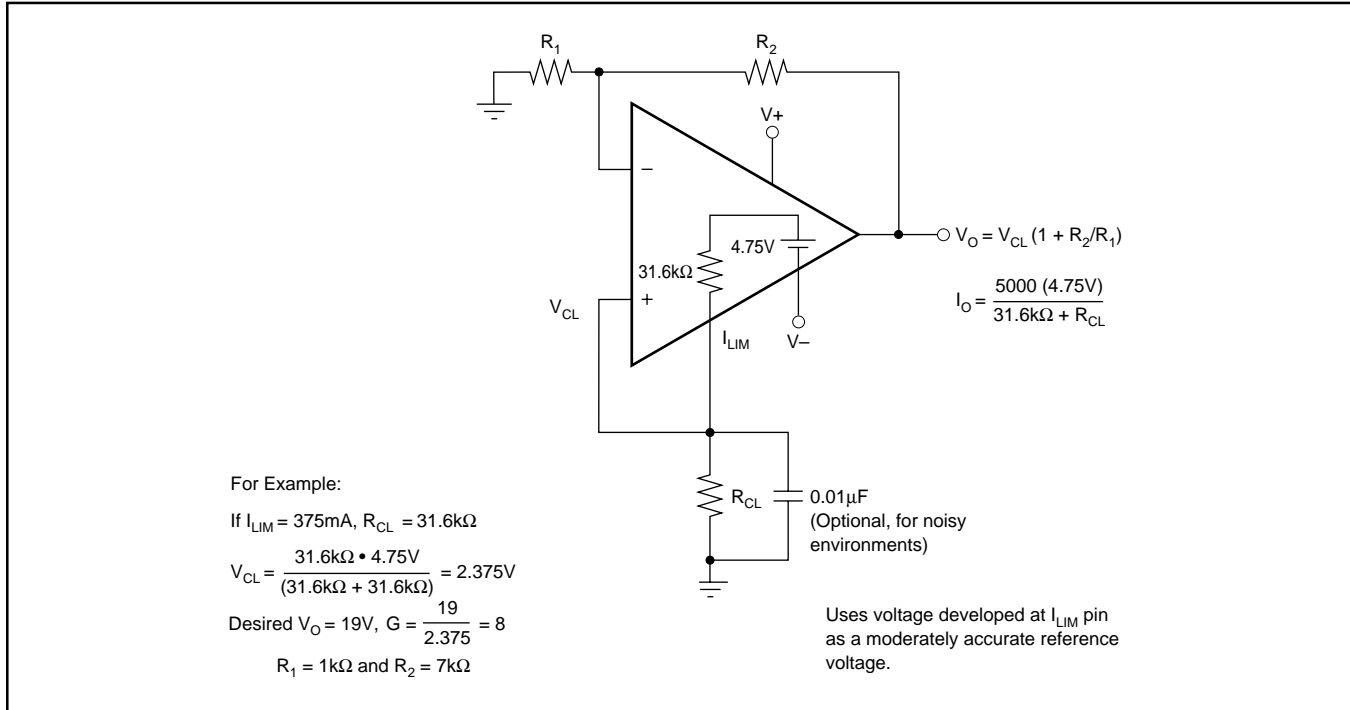

FIGURE 12. Voltage Source.

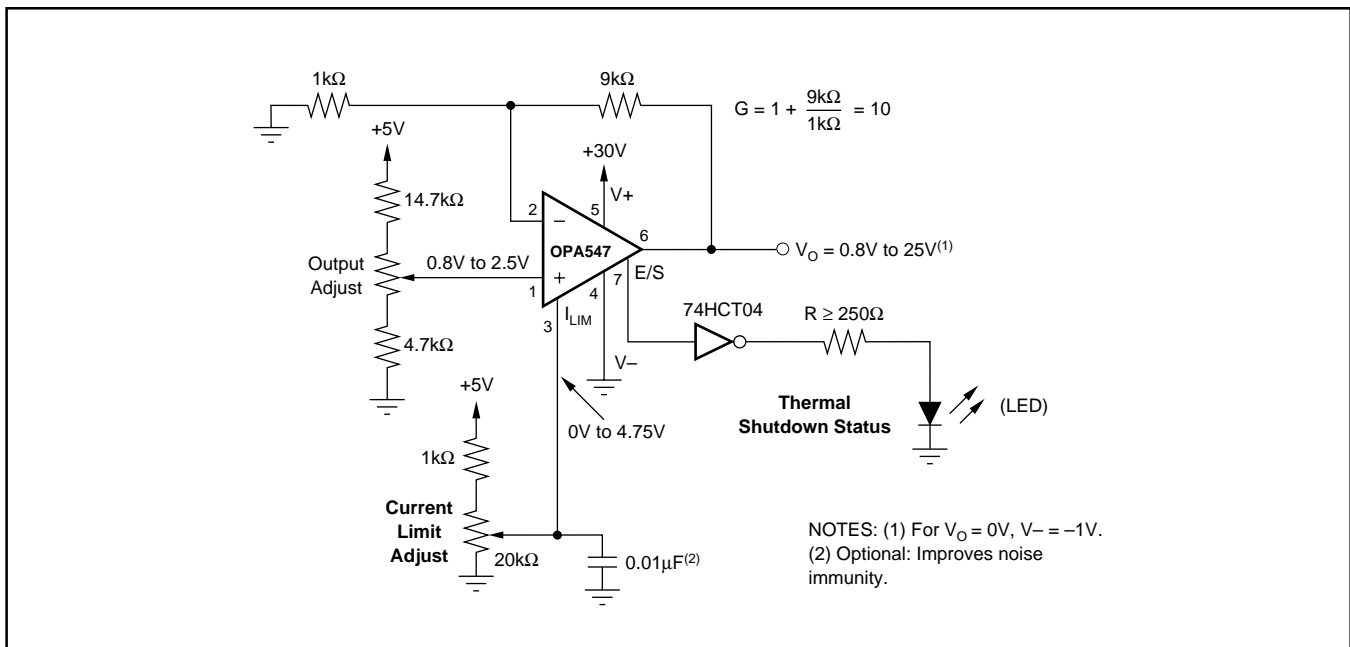

FIGURE 13. Resistor-Controlled Programmable Power Supply.

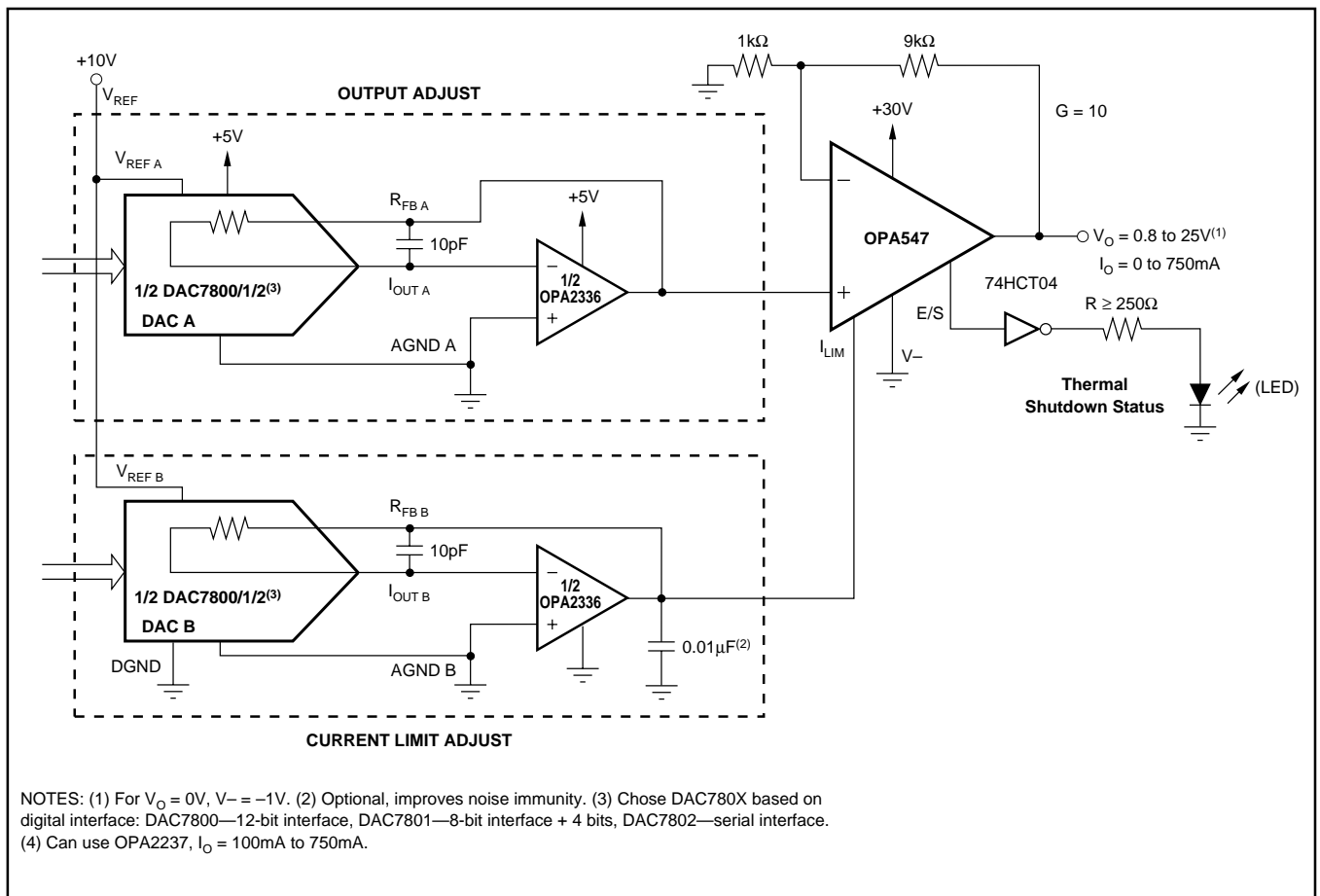

FIGURE 14. Digitally-Controlled Programmable Power Supply.

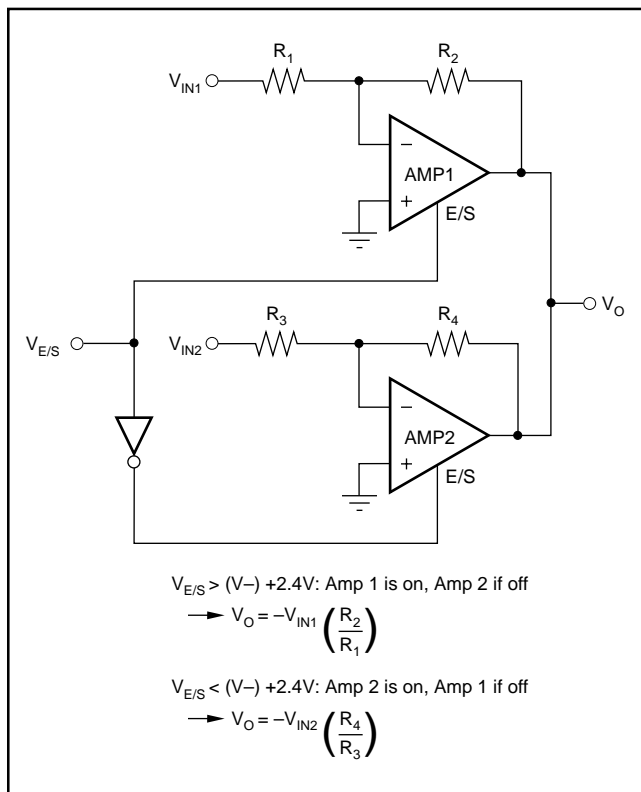

FIGURE 15. Swap Amplifier.

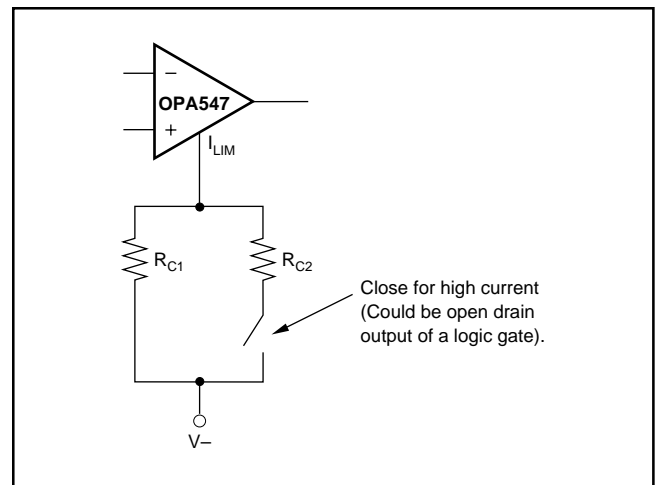

FIGURE 16. Multiple Current Limit Values.

PACKAGING INFORMATION

| Orderable Device | Status ⁽¹⁾ | Package Type | Package Drawing | Pins | Package Qty | Eco Plan ⁽²⁾ | Lead/Ball Finish | MSL Peak Temp ⁽³⁾ |
|------------------|-----------------------|--------------|-----------------|------|-------------|-------------------------|------------------|------------------------------|
| OPA547F | OBSOLETE | DDPAK | KTW | 7 | | TBD | Call TI | Call TI |
| OPA547F/500 | ACTIVE | DDPAK | KTW | 7 | 500 | Green (RoHS & no Sb/Br) | CU SN | Level-2-260C-1 YEAR |
| OPA547F/500G3 | ACTIVE | DDPAK | KTW | 7 | 500 | Green (RoHS & no Sb/Br) | CU SN | Level-2-260C-1 YEAR |
| OPA547FKTWT | ACTIVE | DDPAK | KTW | 7 | 50 | Green (RoHS & no Sb/Br) | CU SN | Level-2-260C-1 YEAR |
| OPA547FKTWTG3 | ACTIVE | DDPAK | KTW | 7 | 50 | Green (RoHS & no Sb/Br) | CU SN | Level-2-260C-1 YEAR |
| OPA547T | ACTIVE | TO-220 | KVT | 7 | 49 | Green (RoHS & no Sb/Br) | CU SN | N / A for Pkg Type |
| OPA547T-1 | ACTIVE | TO-220 | KC | 7 | 49 | Green (RoHS & no Sb/Br) | CU SN | N / A for Pkg Type |
| OPA547T-1G3 | ACTIVE | TO-220 | KC | 7 | 49 | Green (RoHS & no Sb/Br) | CU SN | N / A for Pkg Type |
| OPA547TG3 | ACTIVE | TO-220 | KVT | 7 | 49 | Green (RoHS & no Sb/Br) | CU SN | N / A for Pkg Type |

⁽¹⁾ The marketing status values are defined as follows:

ACTIVE: Product device recommended for new designs.

LIFEBUY: TI has announced that the device will be discontinued, and a lifetime-buy period is in effect.

NRND: Not recommended for new designs. Device is in production to support existing customers, but TI does not recommend using this part in a new design.

PREVIEW: Device has been announced but is not in production. Samples may or may not be available.

OBSOLETE: TI has discontinued the production of the device.

⁽²⁾ Eco Plan - The planned eco-friendly classification: Pb-Free (RoHS), Pb-Free (RoHS Exempt), or Green (RoHS & no Sb/Br) - please check <http://www.ti.com/productcontent> for the latest availability information and additional product content details.

TBD: The Pb-Free/Green conversion plan has not been defined.

Pb-Free (RoHS): TI's terms "Lead-Free" or "Pb-Free" mean semiconductor products that are compatible with the current RoHS requirements for all 6 substances, including the requirement that lead not exceed 0.1% by weight in homogeneous materials. Where designed to be soldered at high temperatures, TI Pb-Free products are suitable for use in specified lead-free processes.

Pb-Free (RoHS Exempt): This component has a RoHS exemption for either 1) lead-based flip-chip solder bumps used between the die and package, or 2) lead-based die adhesive used between the die and leadframe. The component is otherwise considered Pb-Free (RoHS compatible) as defined above.

Green (RoHS & no Sb/Br): TI defines "Green" to mean Pb-Free (RoHS compatible), and free of Bromine (Br) and Antimony (Sb) based flame retardants (Br or Sb do not exceed 0.1% by weight in homogeneous material)

⁽³⁾ MSL, Peak Temp. -- The Moisture Sensitivity Level rating according to the JEDEC industry standard classifications, and peak solder temperature.

Important Information and Disclaimer:The information provided on this page represents TI's knowledge and belief as of the date that it is provided. TI bases its knowledge and belief on information provided by third parties, and makes no representation or warranty as to the accuracy of such information. Efforts are underway to better integrate information from third parties. TI has taken and continues to take reasonable steps to provide representative and accurate information but may not have conducted destructive testing or chemical analysis on incoming materials and chemicals. TI and TI suppliers consider certain information to be proprietary, and thus CAS numbers and other limited information may not be available for release.

In no event shall TI's liability arising out of such information exceed the total purchase price of the TI part(s) at issue in this document sold by TI to Customer on an annual basis.

MECHANICAL DATA

MPSF015 – AUGUST 2001

KTW (R-PSFM-G7)

PLASTIC FLANGE-MOUNT

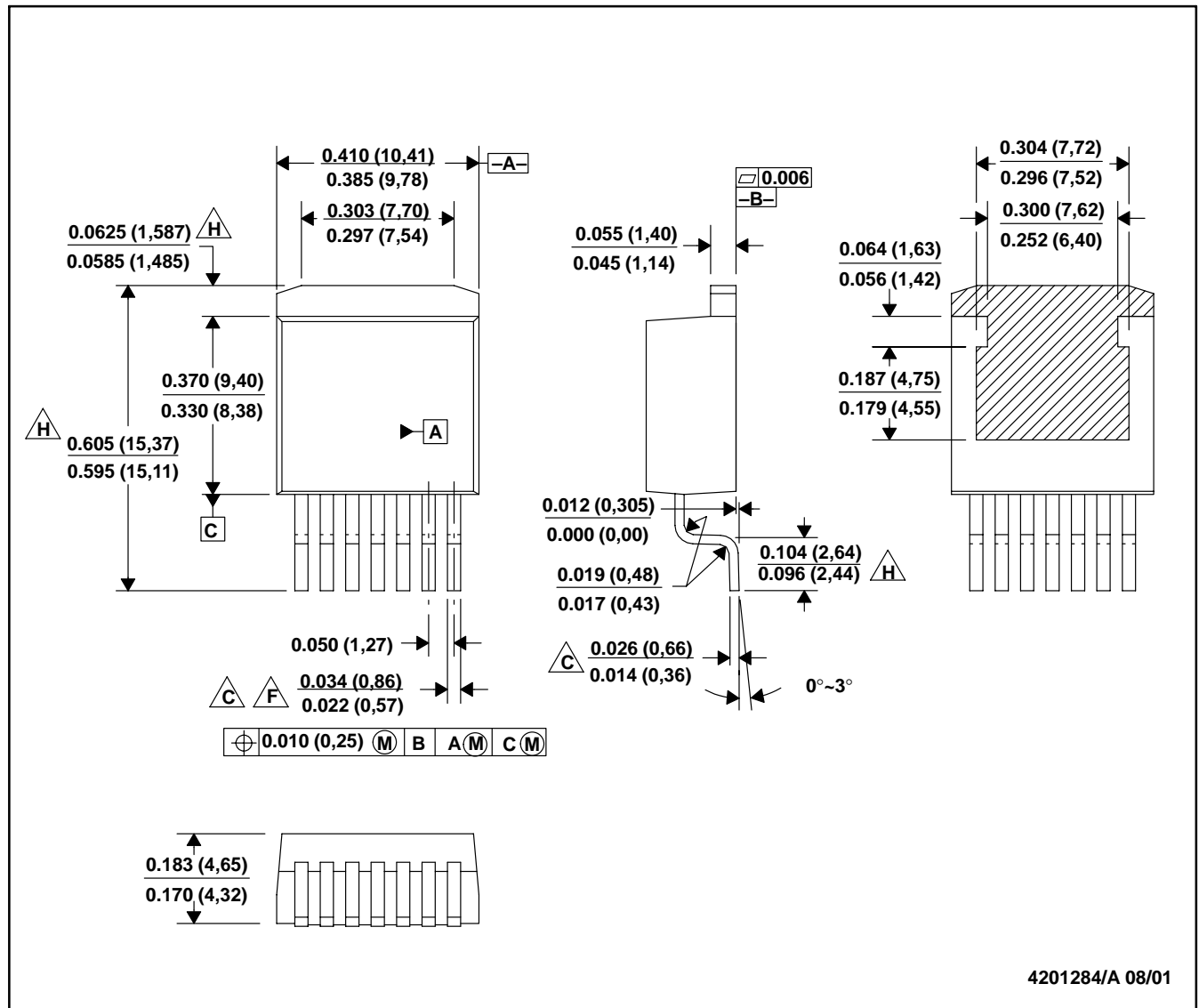

- NOTES:
- A. All linear dimensions are in inches (millimeters).
 - B. This drawing is subject to change without notice.
 - C. Lead width and height dimensions apply to the plated lead.
 - D. Leads are not allowed above the Datum B.
 - E. Stand-off height is measured from lead tip with reference to Datum B.
 - F. Lead width dimension does not include dambar protrusion. Allowable dambar protrusion shall not cause the lead width to exceed the maximum dimension by more than 0.003".
 - G. Cross-hatch indicates exposed metal surface.
 - H. Falls within JEDEC MO-169 with the exception of the dimensions indicated.

KVT (R-PZFM-T7)

PLASTIC FLANGE MOUNT PACKAGE

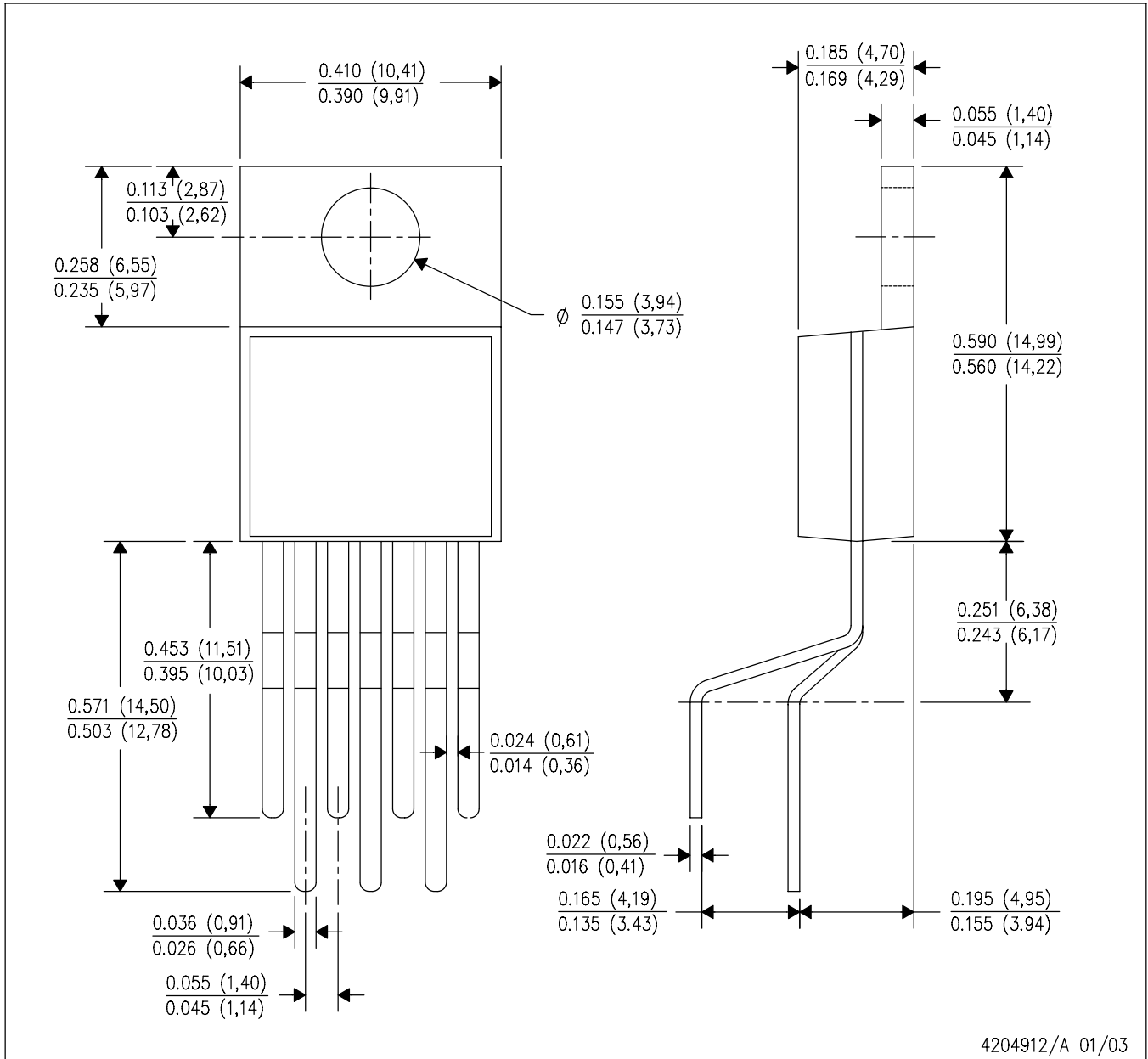

4204912/A 01/03

NOTES: A. All linear dimensions are in inches (millimeters).
 B. This drawing is subject to change without notice.

MECHANICAL DATA

MSOT010 – OCTOBER 1994

KC (R-PSFM-T7)

PLASTIC FLANGE-MOUNT PACKAGE

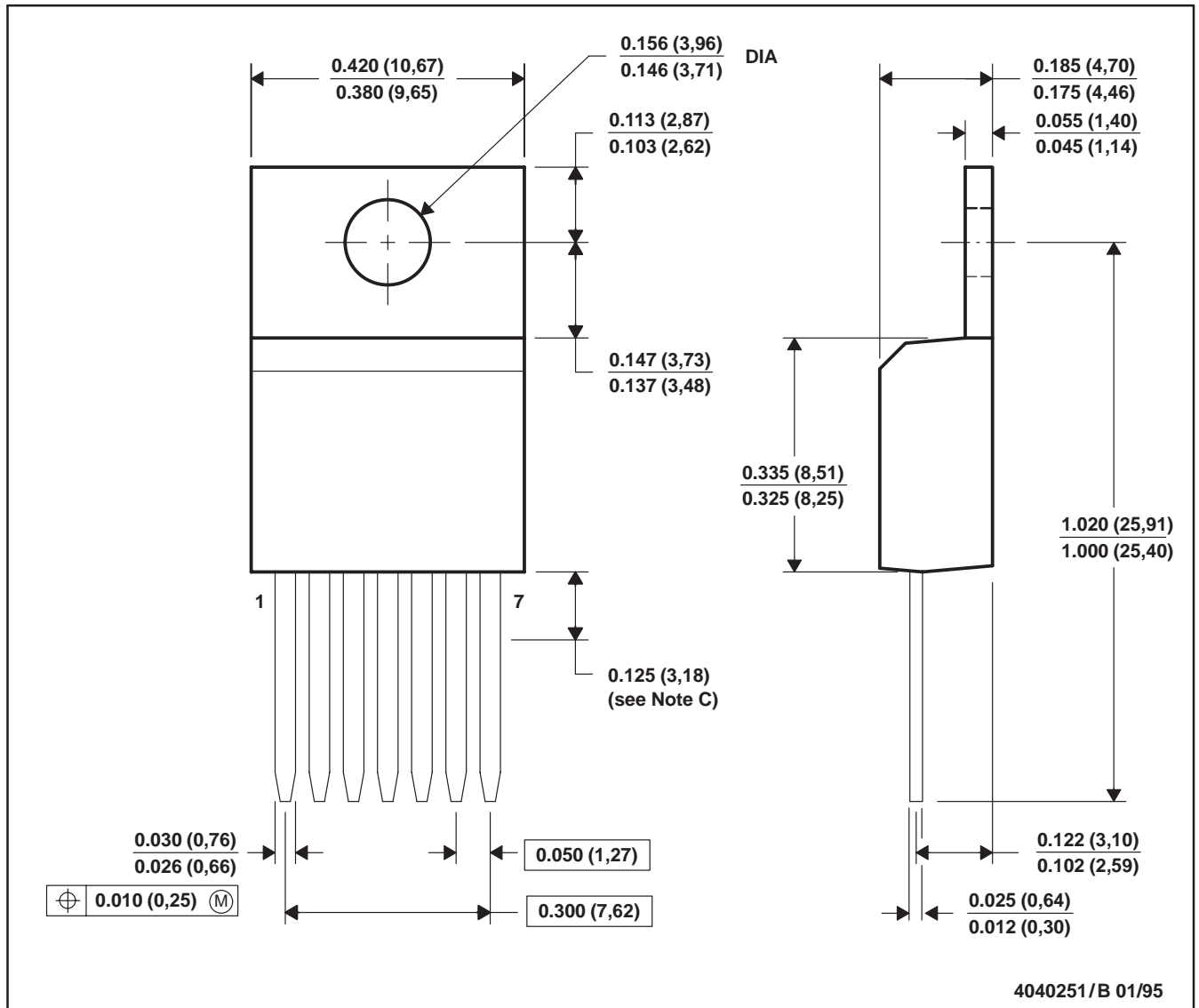

- NOTES: A. All linear dimensions are in inches (millimeters).
 B. This drawing is subject to change without notice.
 C. Lead dimensions are not controlled within this area.
 D. All lead dimensions apply before solder dip.
 E. The center lead is in electrical contact with the mounting tab.

IMPORTANT NOTICE

Texas Instruments Incorporated and its subsidiaries (TI) reserve the right to make corrections, modifications, enhancements, improvements, and other changes to its products and services at any time and to discontinue any product or service without notice. Customers should obtain the latest relevant information before placing orders and should verify that such information is current and complete. All products are sold subject to TI's terms and conditions of sale supplied at the time of order acknowledgment.

TI warrants performance of its hardware products to the specifications applicable at the time of sale in accordance with TI's standard warranty. Testing and other quality control techniques are used to the extent TI deems necessary to support this warranty. Except where mandated by government requirements, testing of all parameters of each product is not necessarily performed.

TI assumes no liability for applications assistance or customer product design. Customers are responsible for their products and applications using TI components. To minimize the risks associated with customer products and applications, customers should provide adequate design and operating safeguards.

TI does not warrant or represent that any license, either express or implied, is granted under any TI patent right, copyright, mask work right, or other TI intellectual property right relating to any combination, machine, or process in which TI products or services are used. Information published by TI regarding third-party products or services does not constitute a license from TI to use such products or services or a warranty or endorsement thereof. Use of such information may require a license from a third party under the patents or other intellectual property of the third party, or a license from TI under the patents or other intellectual property of TI.

Reproduction of information in TI data books or data sheets is permissible only if reproduction is without alteration and is accompanied by all associated warranties, conditions, limitations, and notices. Reproduction of this information with alteration is an unfair and deceptive business practice. TI is not responsible or liable for such altered documentation.

Resale of TI products or services with statements different from or beyond the parameters stated by TI for that product or service voids all express and any implied warranties for the associated TI product or service and is an unfair and deceptive business practice. TI is not responsible or liable for any such statements.

Following are URLs where you can obtain information on other Texas Instruments products and application solutions:

| Products | | Applications | |
|--------------------|--|---------------------|--|
| Amplifiers | amplifier.ti.com | Audio | www.ti.com/audio |
| Data Converters | dataconverter.ti.com | Automotive | www.ti.com/automotive |
| DSP | dsp.ti.com | Broadband | www.ti.com/broadband |
| Interface | interface.ti.com | Digital Control | www.ti.com/digitalcontrol |
| Logic | logic.ti.com | Military | www.ti.com/military |
| Power Mgmt | power.ti.com | Optical Networking | www.ti.com/opticalnetwork |
| Microcontrollers | microcontroller.ti.com | Security | www.ti.com/security |
| Low Power Wireless | www.ti.com/lpw | Telephony | www.ti.com/telephony |
| | | Video & Imaging | www.ti.com/video |
| | | Wireless | www.ti.com/wireless |

Mailing Address: Texas Instruments
Post Office Box 655303 Dallas, Texas 75265