



January 2000  
Revised December 2005

# NC7SB3257

## 2:1 Multiplexer/Demultiplexer Bus Switch

### General Description

The NC7SB3257 is a high performance, 2:1 NMOS passgate multiplexer/demultiplexer. The device is fabricated with advanced sub-micron CMOS technology to achieve high speed enable and disable times and low On Resistance. The device is specified to operate over the 4.0 to 5.5V  $V_{CC}$  operating range. The control input tolerates voltages up to 5.5V independent of the  $V_{CC}$  operating range.

### Features

- Space saving SC70 6-lead surface mount package
- Ultra small MicroPak™ leadless package
- Typical  $3\Omega$  switch resistance @ 5.0V  $V_{CC}$
- Minimal propagation delay through the switch
- Power down high impedance control input
- Zero bounce in flow through mode
- TTL compatible control input
- Overvoltage tolerance of control input to 7.0V
- Break before make enable circuitry

### Ordering Code:

Order Number	Package Number	Product Code Top Mark	Package Description	Supplied As
NC7SB3257P6X	MAA06A	B7B	6-Lead SC70, EIAJ SC88, 1.25mm Wide	3k Units on Tape and Reel
NC7SB3257L6X	MAC06A	B7	Pb-Free 6-Lead MicroPak, 1.0mm Wide	5k Units on Tape and Reel

Pb-Free package per JEDEC J-STD-020B.

NC7SB3257 2:1 Multiplexer/Demultiplexer Bus Switch

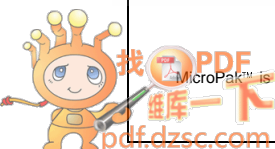

### Logic Symbol

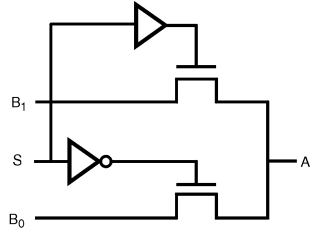

### Pin Descriptions

Pin Names	Description
A, B <sub>0</sub> , B <sub>1</sub>	Data Ports
S	Control Input

### Function Table

Input (S)	Function
L	B <sub>0</sub> Connected to A
H	B <sub>1</sub> Connected to A

H = HIGH Logic Level  
L = LOW Logic Level

### Connection Diagrams

#### Pin Assignments for SC70

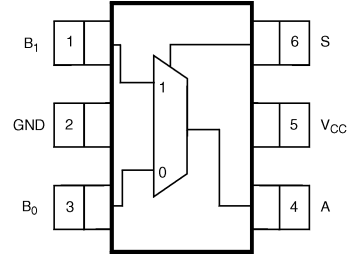

(Top View)

#### Pin One Orientation Diagram

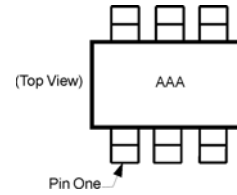

AAA = Product Code Top Mark - see ordering code

**Note:** Orientation of Top Mark determines Pin One location. Read the top product code mark left to right, Pin One is the lower left pin (see diagram).

#### Pad Assignments for MicroPak

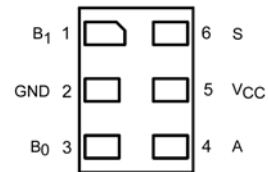

(Top Through View)

### Absolute Maximum Ratings (Note 1)

Supply Voltage ( $V_{CC}$ )	-0.5V to +7.0V
DC Switch Voltage ( $V_S$ )	-0.5V to +7.0V
DC Output Voltage ( $V_{IN}$ ) (Note 3)	-0.5V to +7.0V
DC Input Diode Current ( $I_{IK}$ )	
@ ( $I_{IK}$ ) $V_{IN} < 0V$	-50 mA
DC Output Current ( $I_{OUT}$ )	128 mA
DC $V_{CC}$ or Ground Current ( $I_{CC}/I_{GND}$ )	$\pm 100$ mA
Storage Temperature Range ( $T_{STG}$ )	-65°C to +150°C
Junction Lead Temperature under Bias ( $T_J$ )	+150°C
Lead Temperature ( $T_L$ )	
(Soldering, 10 seconds)	+260°C
Power Dissipation ( $P_D$ ) @ +85°C	180 mW

### Recommended Operating Conditions (Note 2)

Supply Voltage Operating ( $V_{CC}$ )	4.0V to 5.5V
Control Input Voltage ( $V_{IN}$ )	0V to $V_{CC}$
Switch Input Voltage ( $V_{IN}$ )	0V to $V_{CC}$
Output Voltage ( $V_{OUT}$ )	0V to $V_{CC}$
Operating Temperature ( $T_A$ )	-40°C to +85°C
Input Rise and Fall Time ( $t_r, t_f$ )	
Control Input $V_{CC} = 4.0V$ to $5.5V$	0 ns/V to 5 ns/V
Thermal Resistance ( $\theta_{JA}$ )	350°C/W

**Note 1:** Absolute maximum ratings are DC values beyond which the device may be damaged or have its useful life impaired. The datasheet specifications should be met, without exception, to ensure that the system design is reliable over its power supply, temperature, and output/input loading variables. Fairchild does not recommend operation outside datasheet specifications.

**Note 2:** Control input must be held HIGH or LOW, it must not float.

**Note 3:** The input and output negative voltage ratings may be exceeded if the input and output diode current ratings are observed.

### DC Electrical Characteristics

Symbol	Parameter	$V_{CC}$ (V)	$T_A = -40^\circ\text{C to } +85^\circ\text{C}$			Units	Conditions
			Min	Typ	Max		
$V_{IK}$	Clamp Diode Voltage	4.5			-1.2	V	$I_{IN} = -18$ mA
$V_{IH}$	HIGH Level Input Voltage	4.5 – 5.5	2.0			V	
$V_{IL}$	LOW Level Input Voltage	4.5 – 5.5			0.8		
$I_{IN}$	Input Leakage Current	5.5			$\pm 1.0$	$\mu\text{A}$	$0 \leq V_{IN} \leq 5.5V$
$I_{OFF}$	OFF State Leakage Current	5.5			$\pm 1.0$	$\mu\text{A}$	$0 \leq A, B \leq V_{CC}$
$R_{ON}$	Switch On Resistance (Note 4)	4.5		3.0	7.0	$\Omega$	$V_{IN} = 0V, I_{IN} = 64$ mA
		4.5		3.0	7.0	$\Omega$	$V_{IN} = 0V, I_{IN} = 30$ mA
		4.5		6.0	15.0	$\Omega$	$V_{IN} = 2.4V, I_{IN} = 15$ mA
		4.0		10.0	20.0	$\Omega$	$V_{IN} = 2.4V, I_{IN} = 15$ mA
$I_{CC}$	Quiescent Supply Current	5.5			10.0	$\mu\text{A}$	$V_{IN} = V_{CC}$ or GND $I_{OUT} = 0$
$\Delta I_{CC}$	Increase in $I_{CC}$ Per Input (Note 5)	5.5		0.9	2.5	mA	$V_{IN} = 3.4V, I_O = 0$ Control Input Only

**Note 4:** Measured by the voltage drop between A and B pins at the indicated current through the switch. On Resistance is determined by the lower of the voltages on the two (A or B Ports).

**Note 5:** Per TTL driven Input ( $V_{IN} = 3.4V$ , Control input only). A and B pins do not contribute to  $I_{CC}$ .

## AC Electrical Characteristics

Symbol	Parameter	V <sub>CC</sub> (V)	T <sub>A</sub> = -40°C to +85°C C <sub>L</sub> = 50 pF, R <sub>U</sub> = R <sub>D</sub> = 500Ω			Units	Conditions	Figure Number
			Min	Typ	Max			
t <sub>PHL</sub> t <sub>PLH</sub>	Propagation Delay Bus to Bus (Note 6)	4.0 – 5.5			0.25	ns	V <sub>I</sub> = OPEN	Figures 1, 2
t <sub>PZL</sub> t <sub>PZH</sub>	Output Enable Time	4.5 – 5.5	1.8		6.5	ns	V <sub>I</sub> = 7V for t <sub>PZL</sub> V <sub>I</sub> = 0V for t <sub>PZH</sub>	Figures 1, 2
t <sub>PLZ</sub> t <sub>PHZ</sub>	Output Disable Time	4.5 – 5.5	0.8		4.7		V <sub>I</sub> = 7V for t <sub>PLZ</sub> V <sub>I</sub> = 0V for t <sub>PHZ</sub>	
t <sub>B-M</sub>	Break Before Make Time (Note 7)	4.5 – 5.5	0.5			ns		Figure 3
		4.0	0.5					

**Note 6:** This parameter is guaranteed by design but not tested. The bus switch contributes no propagation delay other than the RC delay of the On Resistance of the switch and the 50 pF load capacitance, when driven by an ideal voltage source (zero output impedance).

**Note 7:** Guaranteed by design.

## Capacitance (Note 8)

Symbol	Parameter	Typ	Max	Units	Conditions
C <sub>IN</sub>	Control Pin Input Capacitance	2.3		pF	V <sub>CC</sub> = 0V
C <sub>IO-B</sub>	B Port OFF Capacitance	5.7		pF	V <sub>CC</sub> = 5.0V
C <sub>IO-A</sub>	A Port ON Capacitance	16.0		pF	V <sub>CC</sub> = 5.0V

**Note 8:** Capacitance is characterized but not tested.

## AC Loading and Waveforms

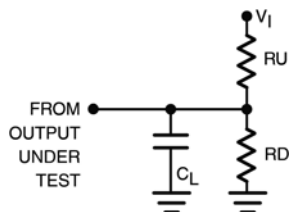

**Note:** Input Driven by 50Ω source terminated in 50Ω

**Note:**  $C_L$  includes load and stray capacitance

**Note:** Input PRR = 1.0 MHz;  $t_W = 500$  ns

**FIGURE 1. AC Test Circuit**

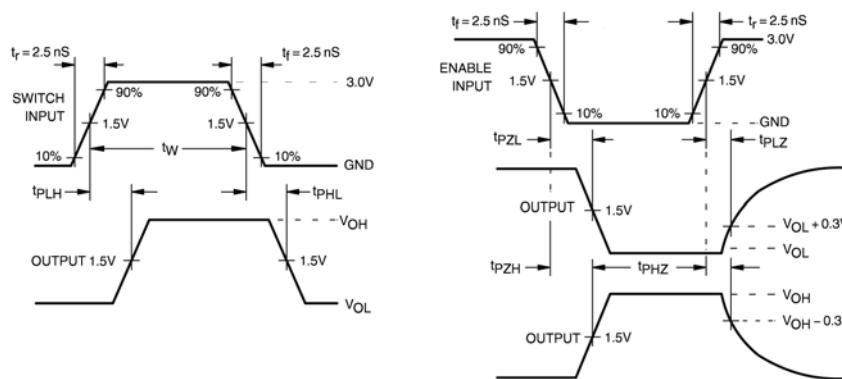

Input = AC Waveform;  
PRR = Variable; Duty Cycle = 50%

**FIGURE 2. AC Waveforms**

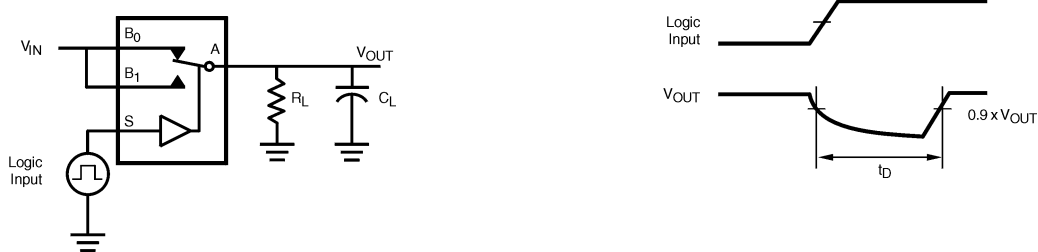

**FIGURE 3. Break Before Make Interval Timing**

## Tape and Reel Specification

TAPE FORMAT for SC70

Package Designator	Tape Section	Number Cavities	Cavity Status	Cover Tape Status
P6X	Leader (Start End)	125 (typ)	Empty	Sealed
	Carrier	3000	Filled	Sealed
	Trailer (Hub End)	75 (typ)	Empty	Sealed

TAPE DIMENSIONS inches (millimeters)

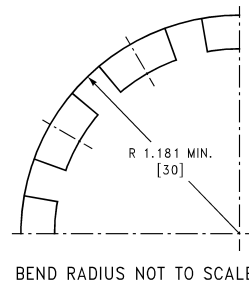
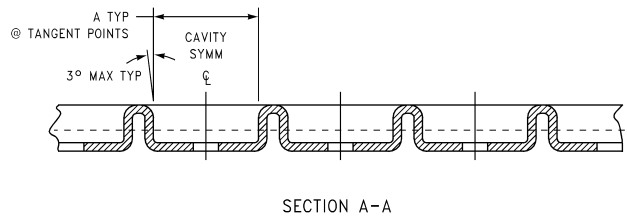
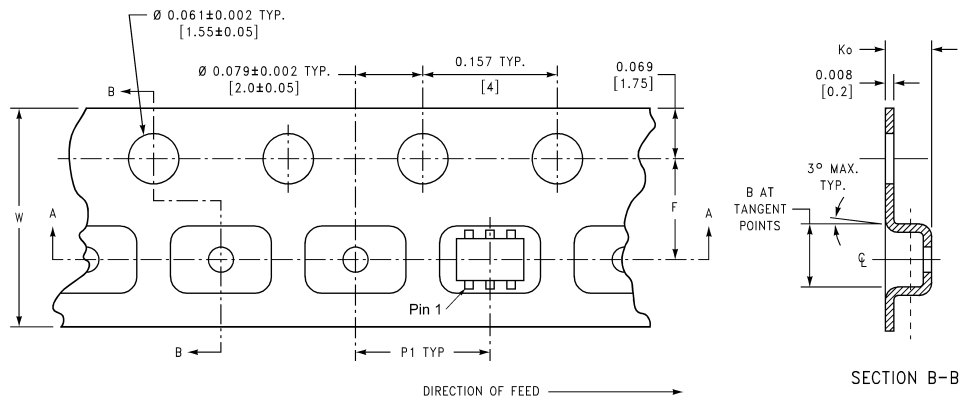

Package	Tape Size	DIM A	DIM B	DIM F	DIM K <sub>o</sub>	DIM P1	DIM W
SC70-6	8 mm	0.093 (2.35)	0.096 (2.45)	0.138 ± 0.004 (3.5 ± 0.10)	0.053 ± 0.004 (1.35 ± 0.10)	0.157 (4)	0.315 ± 0.004 (8 ± 0.1)

**TAPE FORMAT for MicroPak**

Package Designator	Tape Section	Number Cavities	Cavity Status	Cover Tape Status
L6X	Leader (Start End)	125 (typ)	Empty	Sealed
	Carrier	5000	Filled	Sealed
	Trailer (Hub End)	75 (typ)	Empty	Sealed

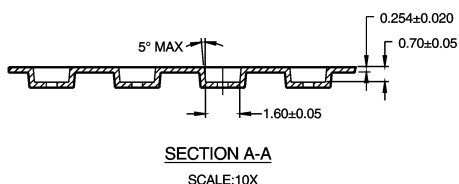
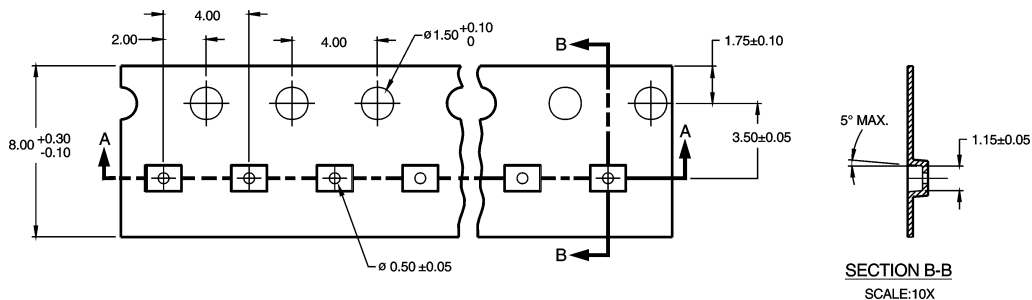

**REEL DIMENSIONS** inches (millimeters)

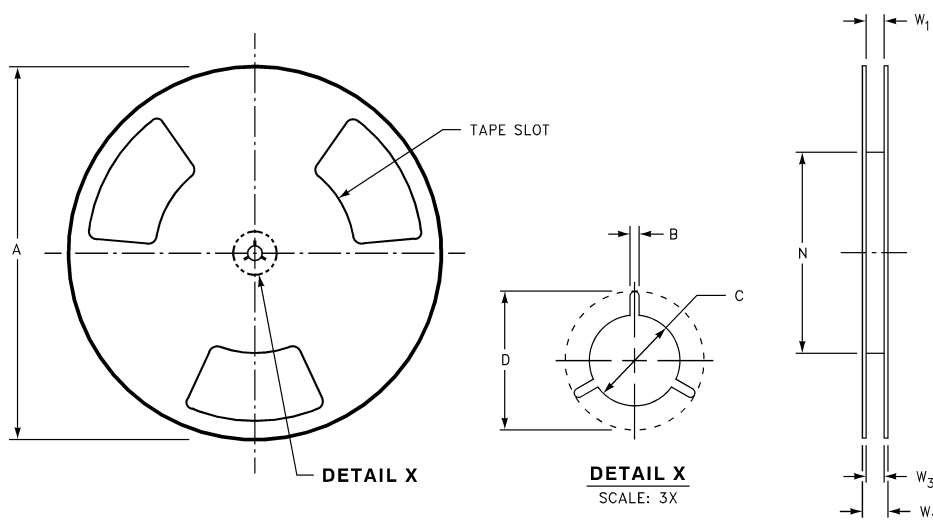

Tape Size	A	B	C	D	N	W1	W2	W3
8 mm	7.0 (177.8)	0.059 (1.50)	0.512 (13.00)	0.795 (20.20)	2.165 (55.00)	0.331 + 0.059/-0.000 (8.40 + 1.50/-0.00)	0.567 (14.40)	W1 + 0.078/-0.039 (W1 + 2.00/-1.00)

**Physical Dimensions** inches (millimeters) unless otherwise noted

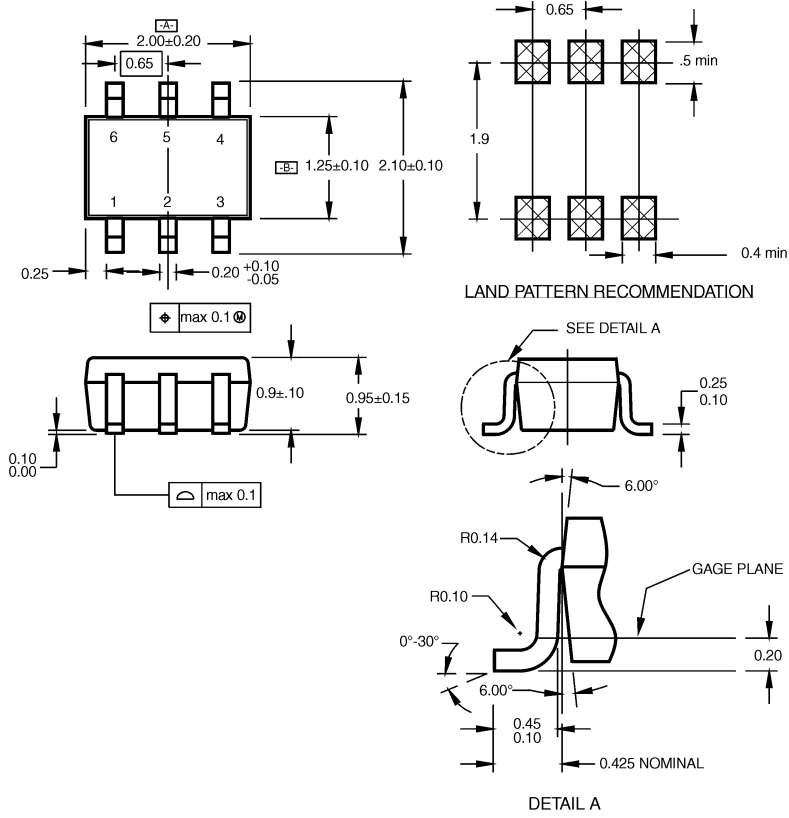

- NOTES:  
 A. CONFORMS TO EIAJ REGISTERED OUTLINE DRAWING SC88.  
 B. DIMENSIONS DO NOT INCLUDE BURRS OR MOLD FLASH.  
 C. DIMENSIONS ARE IN MILLIMETERS.

MAA06ARevC

**6-Lead SC70, EIAJ SC88, 1.25mm Wide  
 Package Number MAA06A**



**Physical Dimensions** inches (millimeters) unless otherwise noted (Continued)

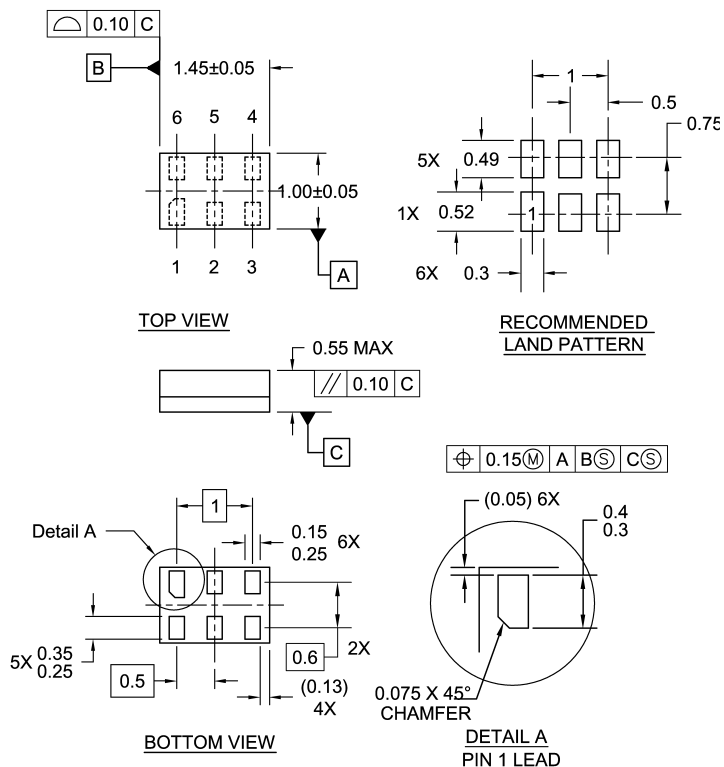

- Notes:
1. JEDEC PACKAGE REGISTRATION IS ANTICIPATED
  2. DIMENSIONS ARE IN MILLIMETERS
  3. DRAWING CONFORMS TO ASME Y14.5M-1994

MAC06ARevB

**Pb-Free 6-Lead MicroPak, 1.0mm Wide  
Package Number MAC06A**

**DISCLAIMER**

FAIRCHILD SEMICONDUCTOR RESERVES THE RIGHT TO MAKE CHANGES WITHOUT FURTHER NOTICE TO ANY PRODUCTS HEREIN TO IMPROVE RELIABILITY, FUNCTION OR DESIGN. FAIRCHILD DOES NOT ASSUME ANY LIABILITY ARISING OUT OF THE APPLICATION OR USE OF ANY PRODUCT OR CIRCUIT DESCRIBED HEREIN; NEITHER DOES IT CONVEY ANY LICENSE UNDER ITS PATENT RIGHTS, NOR THE RIGHTS OF OTHERS.

**LIFE SUPPORT POLICY**

FAIRCHILD'S PRODUCTS ARE NOT AUTHORIZED FOR USE AS CRITICAL COMPONENTS IN LIFE SUPPORT DEVICES OR SYSTEMS WITHOUT THE EXPRESS WRITTEN APPROVAL OF FAIRCHILD SEMICONDUCTOR CORPORATION

As used herein:

1. Life support devices or systems are devices or systems which, (a) are intended for surgical implant into the body, or (b) support or sustain life, or (c) whose failure to perform when properly used in accordance with instructions for use

provided in the labeling, can be reasonably expected to result in significant injury to the user.

2. A critical component is any component of a life support device or system whose failure to perform can be reasonably expected to cause the failure of the life support device or system, or to affect its safety or effectiveness.

**PRODUCT STATUS DEFINITIONS**

Definition of terms

Datasheet Identification	Product Status	Definition
Advance Information	Formative or In Design	This datasheet contains the design specifications for product development. Specifications may change in any manner without notice.
Preliminary	First Production	This datasheet contains preliminary data, and supplementary data will be published at a later date. Fairchild Semiconductor reserves the right to make changes at any time without notice in order to improve design.
No Identification Needed	Full Production	This datasheet contains final specifications. Fairchild Semiconductor reserves the right to make changes at any time without notice in order to improve design.
Obsolete	Not In Production	This datasheet contains specifications on a product that has been discontinued by Fairchild Semiconductor. The datasheet is printed for reference information only.