

FLK107MH-14

X, Ku Band Power GaAs FET

FEATURES

- High Output Power: $P_{1dB} = 30.0dBm(Typ.)$
- High Gain: $G_{1dB} = 6.5dB(Typ.)$
- High PAE: $\eta_{add} = 31%(Typ.)$
- Proven Reliability
- Hermetic Metal/Ceramic Package

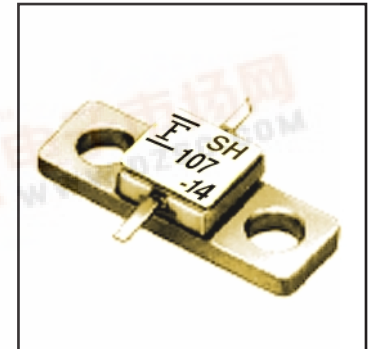

DESCRIPTION

The FLK102MH-14 is a power GaAs FET that is designed for general purpose applications in the Ku-Band frequency range as it provides superior power, gain, and efficiency.

Fujitsu's stringent Quality Assurance Program assures the highest reliability and consistent performance.

ABSOLUTE MAXIMUM RATING (Ambient Temperature $T_a=25^{\circ}C$)

Item	Symbol	Condition	Rating	Unit
Drain-Source Voltage	V_{DS}		15	V
Gate-Source Voltage	V_{GS}		-5	V
Total Power Dissipation	P_T	$T_C = 25^{\circ}C$	7.5	W
Storage Temperature	T_{stg}		-65 to +175	$^{\circ}C$
Channel Temperature	T_{ch}		175	$^{\circ}C$

Fujitsu recommends the following conditions for the reliable operation of GaAs FETs:

1. The drain-source operating voltage (V_{DS}) should not exceed 10 volts.
2. The forward and reverse gate currents should not exceed 8.8 and -0.5 mA respectively with gate resistance of 500 Ω .
3. The operating channel temperature (T_{ch}) should not exceed 145 $^{\circ}C$.

ELECTRICAL CHARACTERISTICS (Ambient Temperature $T_a=25^{\circ}C$)

Item	Symbol	Test Conditions	Limit			Unit
			Min.	Typ.	Max.	
Saturated Drain Current	I_{DSS}	$V_{DS} = 5V, V_{GS} = 0V$	-	400	600	mA
Transconductance	g_m	$V_{DS} = 5V, I_{DS} = 250mA$	-	200	-	mS
Pinch-off Voltage	V_p	$V_{DS} = 5V, I_{DS} = 20mA$	-1.0	-2.0	-3.5	V
Gate Source Breakdown Voltage	V_{GSO}	$I_{GS} = -20\mu A$	-5	-	-	V
Output Power at 1dB G.C.P.	P_{1dB}	$V_{DS} = 10V,$ $I_{DS} = 0.6 I_{DSS} (Typ.),$ $f = 14.5 GHz$	29.0	30.0	-	dBm
Power Gain at 1dB G.C.P.	G_{1dB}		5.5	6.5	-	dB
Power-added Efficiency	η_{add}		-	31	-	%
Thermal Resistance	R_{th}	Channel to Case	-	15	20	$^{\circ}C/W$

CASE STYLE: MH

G.C.P.: Gain Compression Point

FLK107MH-14

X, Ku Band Power GaAs FET

POWER DERATING CURVE

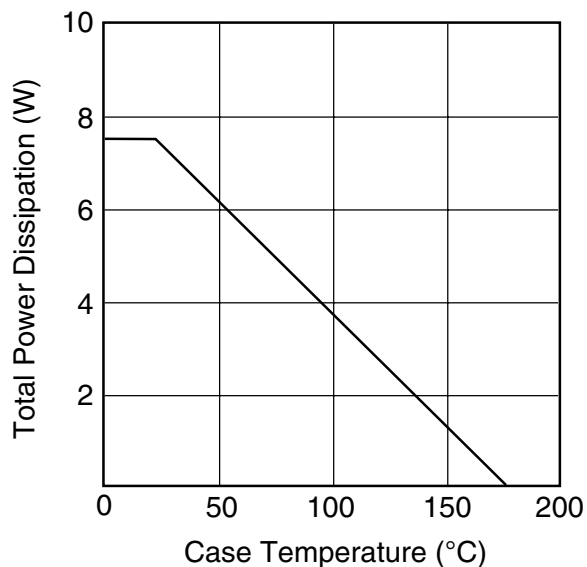

DRAIN CURRENT vs. DRAIN-SOURCE VOLTAGE

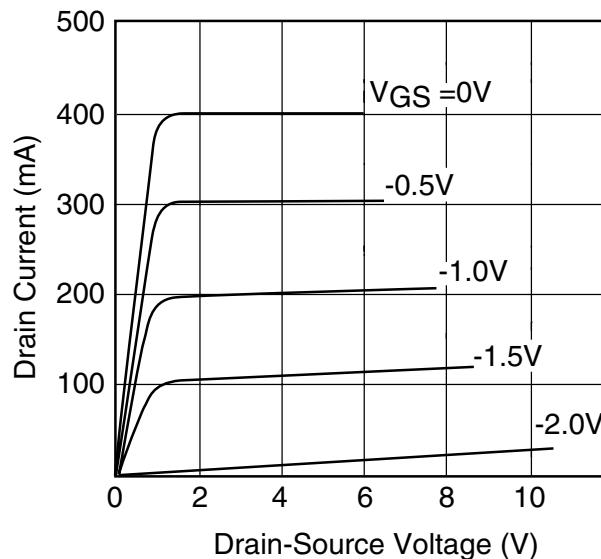

OUTPUT POWER vs. INPUT POWER

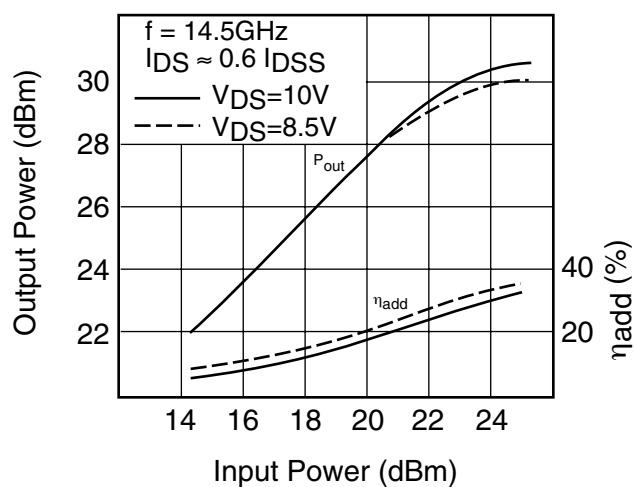

P_{1dB} & η_{add} vs. V_{DS}

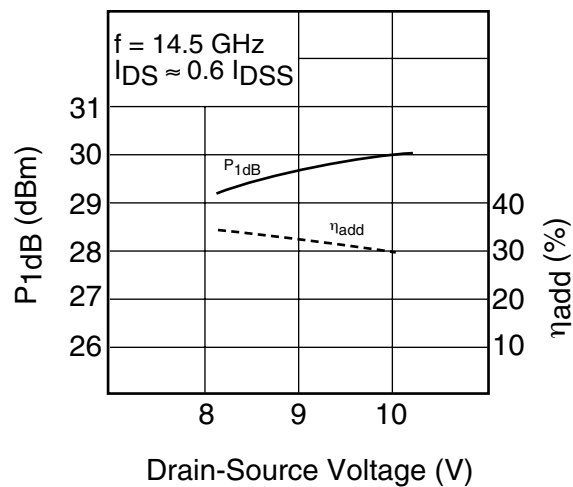

FLK107MH-14

X, Ku Band Power GaAs

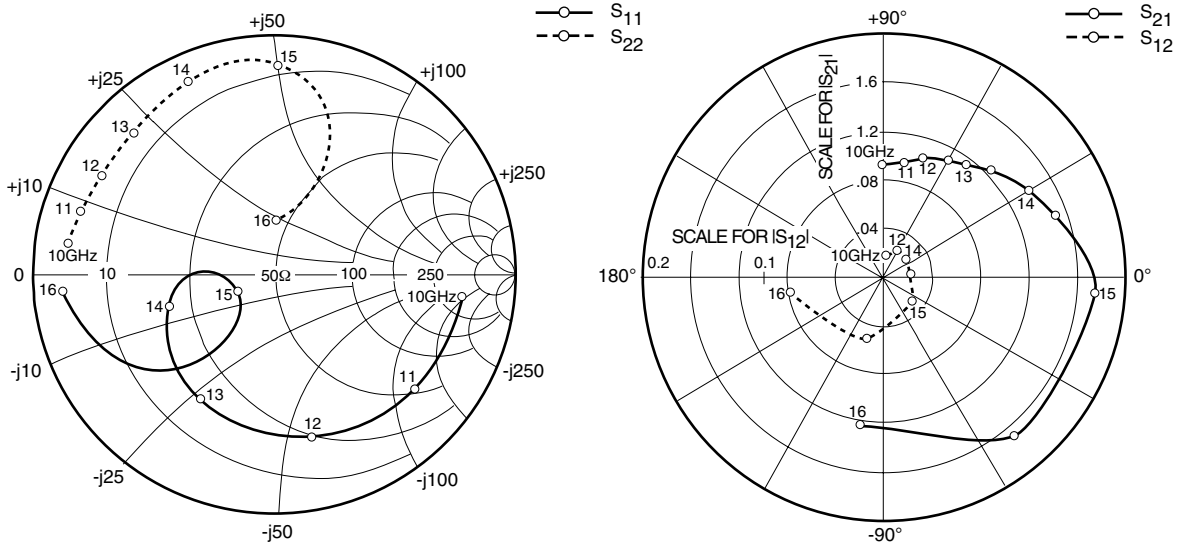

S-PARAMETERS

$V_{DS} = 10V, I_{DS} = 240mA$

FREQUENCY (MHZ)	S11		S21		S12		S22	
	MAG	ANG	MAG	ANG	MAG	ANG	MAG	ANG
500	.949	-99.8	8.893	131.6	.023	47.7	.275	-58.0
1000	.921	-137.6	5.628	114.8	.028	37.1	.297	-80.9
10000	.783	-6.8	.924	90.5	.039	71.6	.852	171.3
10500	.769	-22.8	.932	85.8	.038	64.4	.857	166.9
11000	.751	-39.7	.959	79.8	.039	67.8	.843	161.7
11500	.730	-57.4	.981	74.2	.043	63.7	.827	156.0
12000	.699	-76.9	1.032	71.9	.049	62.1	.825	149.9
12500	.659	-98.1	1.109	60.8	.044	63.5	.820	142.6
13000	.609	-119.9	1.151	53.5	.045	64.8	.824	134.6
13500	.544	-142.1	1.255	44.7	.045	51.5	.851	125.6
14000	.456	-162.6	1.402	30.5	.046	37.2	.890	113.9
14500	.331	179.3	1.521	19.7	.045	7.2	.913	102.8
15000	.170	-155.0	1.764	-4.8	.063	-39.7	.875	89.2
15500	.528	-132.8	1.697	-50.1	.108	-107.7	.654	69.0
16000	.878	-174.9	1.225	-99.6	.158	-171.2	.226	87.9

FLK107MH-14

X, Ku Band Power GaAs FET

Case Style "MH" Metal-Ceramic Hermetic Package

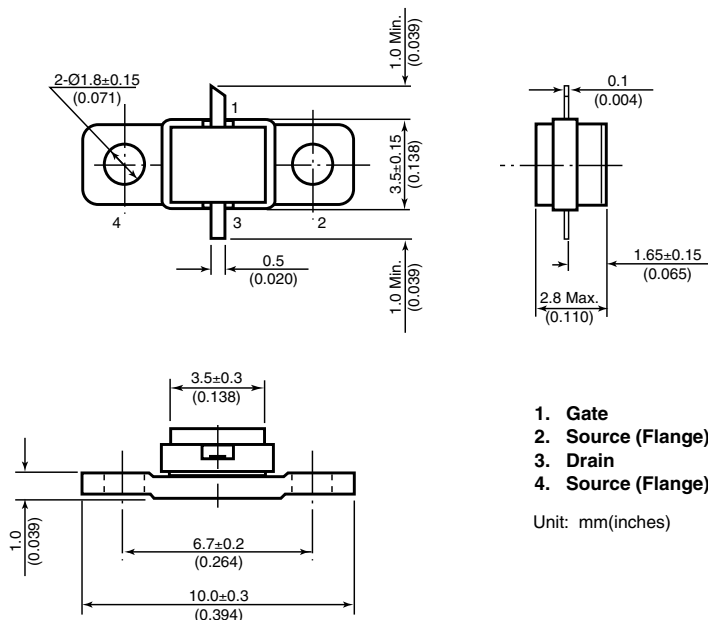

For further information please contact:

FUJITSU COMPOUND SEMICONDUCTOR, INC.

2355 Zanker Rd.

San Jose, CA 95131-1138, U.S.A.

Phone: (408) 232-9500

FAX: (408) 428-9111

www.fcsi.fujitsu.com

FUJITSU MICROELECTRONICS, LTD.

Compound Semiconductor Division

Network House

Norreys Drive

Maidenhead, Berkshire SL6 4FJ

Phone: +44 (0)1628 504800

FAX: +44 (0)1628 504888

CAUTION

Fujitsu Compound Semiconductor Products contain **gallium arsenide (GaAs)** which can be hazardous to the human body and the environment. For safety, observe the following procedures:

- Do not put these products into the mouth.
- Do not alter the form of this product into a gas, powder, or liquid through burning, crushing, or chemical processing as these by-products are dangerous to the human body if inhaled, ingested, or swallowed.
- Observe government laws and company regulations when discarding this product. This product must be discarded in accordance with methods specified by applicable hazardous waste procedures.

Fujitsu Limited reserves the right to change products and specifications without notice. The information does not convey any license under rights of Fujitsu Limited or others.

© 1998 FUJITSU COMPOUND SEMICONDUCTOR, INC.

Printed in U.S.A. FCSI0598M200