

$V_{RRM}$	=	6000 V	<h2>Fast Recovery Diode</h2> <h1>5SDF 10H6004</h1>
$I_{F(AV)M}$	=	1100 A	
$I_{FSM}$	=	$18 \times 10^3$ A	
$V_{(T0)}$	=	1.5 V	
$r_T$	=	0.6 mW	
$V_{DC-link}$	=	3800 V	

Doc. No. 5SYA1109-02 Oct. 06

- Patented free-floating silicon technology
- Low on-state and switching losses
- Optimized for use as freewheeling diode in high-voltage GTO converters
- Industry standard housing
- Cosmic radiation withstand rating

### Blocking

Maximum rated values <sup>1)</sup>

Parameter	Symbol	Conditions	Value	Unit
Repetitive peak reverse voltage	$V_{RRM}$	$f = 50$ Hz, $t_p = 10$ ms, $T_{vj} = 125^\circ\text{C}$	6000	V
Permanent DC voltage for 100 FIT failure rate	$V_{DC-link}$	Ambient cosmic radiation at sea level in open air. (100% Duty)	3800	V

Characteristic values

Parameter	Symbol	Conditions	min	typ	max	Unit
Repetitive peak reverse current	$I_{RRM}$	$V_R = V_{RRM}$ , $T_{vj} = 125^\circ\text{C}$			50	mA

### Mechanical data

Maximum rated values <sup>1)</sup>

Parameter	Symbol	Conditions	min	typ	max	Unit
Mounting force	$F_m$		36	40	44	kN
Acceleration	a	Device unclamped			50	$\text{m/s}^2$
Acceleration	a	Device clamped			200	$\text{m/s}^2$

Characteristic values

Parameter	Symbol	Conditions	min	typ	max	Unit
Weight	m				0.83	kg
Housing thickness	H		26.2		26.6	mm
Surface creepage distance	$D_s$		30			mm
Air strike distance	$D_a$		20			mm

Note 1 Maximum rated values indicate limits beyond which damage to the device may occur



## On-state

### Maximum rated values <sup>1)</sup>

Parameter	Symbol	Conditions	min	typ	max	Unit
Max. average on-state current	$I_{F(AV)M}$	Half sine wave, $T_C = 85\text{ °C}$			1100	A
Max. RMS on-state current	$I_{F(RMS)}$				1700	A
Max. peak non-repetitive surge current	$I_{FSM}$	$t_p = 10\text{ ms}$ , $T_{vj} = 125\text{ °C}$ , $V_R = 0\text{ V}$			$18 \times 10^3$	A
Limiting load integral	$I^2t$				$1.62 \times 10^6$	A <sup>2</sup> s
Max. peak non-repetitive surge current	$I_{FSM}$	$t_p = 1\text{ ms}$ , $T_{vj} = 125\text{ °C}$ , $V_R = 0\text{ V}$			$44 \times 10^3$	A
Limiting load integral	$I^2t$				$968 \times 10^3$	A <sup>2</sup> s

### Characteristic values

Parameter	Symbol	Conditions	min	typ	max	Unit
On-state voltage	$V_F$	$I_F = 2500\text{ A}$ , $T_{vj} = 125\text{ °C}$			3	V
Threshold voltage	$V_{(T0)}$	$T_{vj} = 125\text{ °C}$			1.5	V
Slope resistance	$r_T$	$I_F = 200\text{...}6000\text{ A}$			0.6	mΩ

## Turn-on

### Characteristic values

Parameter	Symbol	Conditions	min	typ	max	Unit
Peak forward recovery voltage	$V_{FRM}$	$di/dt = 500\text{ A}/\mu\text{s}$ , $T_{vj} = 125\text{ °C}$			150	V

## Turn-off

### Characteristic values

Parameter	Symbol	Conditions	min	typ	max	Unit
Reverse recovery current	$I_{RM}$	$di/dt = 300\text{ A}/\mu\text{s}$ , $I_{FQ} = 1000\text{ A}$ , $T_j = 125\text{ °C}$ , $V_{RM} = 2900\text{ V}$ ,			1000	A
Reverse recovery charge	$Q_{rr}$		$C_S = 3\text{ }\mu\text{F}$ (GTO snubber circuit)			6000
Turn-off energy	$E_{rr}$				5	J

### Thermal

Maximum rated values <sup>1)</sup>

Parameter	Symbol	Conditions	min	typ	max	Unit
Operating junction temperature range	T <sub>vj</sub>		-40		125	°C
Storage temperature range	T <sub>stg</sub>		-40		125	°C

Characteristic values

Parameter	Symbol	Conditions	min	typ	max	Unit
Thermal resistance junction to case	R <sub>th(j-c)</sub>	Double-side cooled F <sub>m</sub> = 36...44 kN			12	K/kW
	R <sub>th(j-c)A</sub>	Anode-side cooled F <sub>m</sub> = 36...44 kN			24	K/kW
	R <sub>th(j-c)C</sub>	Cathode-side cooled F <sub>m</sub> = 36...44 kN			24	K/kW
Thermal resistance case to heatsink	R <sub>th(c-h)</sub>	Double-side cooled F <sub>m</sub> = 36...44 kN			3	K/kW
	R <sub>th(c-h)</sub>	Single-side cooled F <sub>m</sub> = 36...44 kN			6	K/kW

Analytical function for transient thermal impedance:

$$Z_{th(j-c)}(t) = \sum_{i=1}^n R_{th i} (1 - e^{-t/\tau_i})$$

i	1	2	3	4
R <sub>th i</sub> (K/kW)	7.440	2.000	1.840	0.710
τ <sub>i</sub> (s)	0.4700	0.0910	0.0100	0.0047

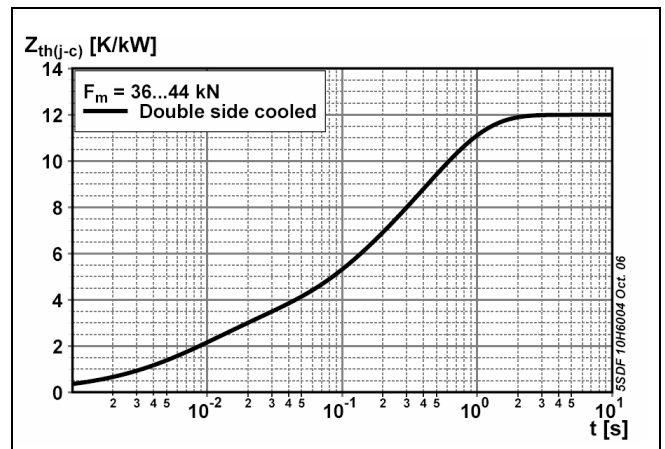

Fig. 1 Transient thermal impedance junction-to-case

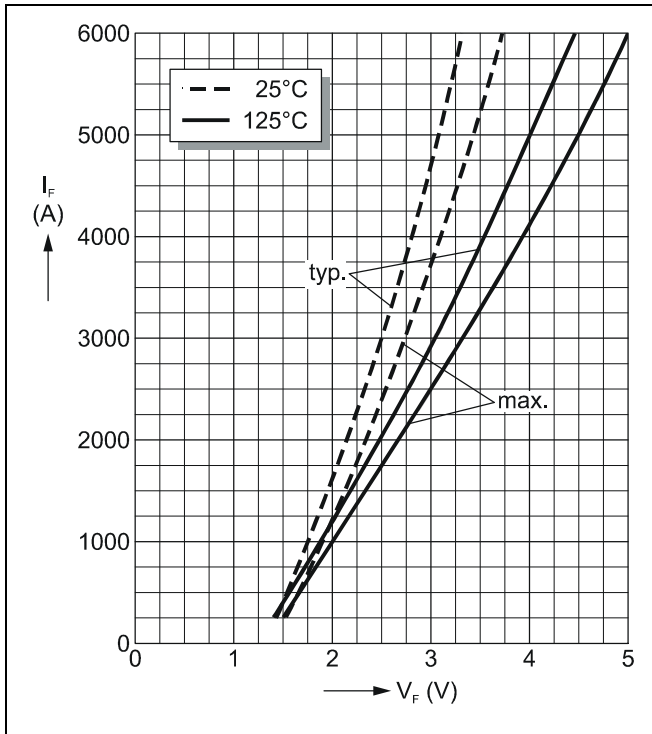

Fig. 2 Max. on-state voltage characteristics

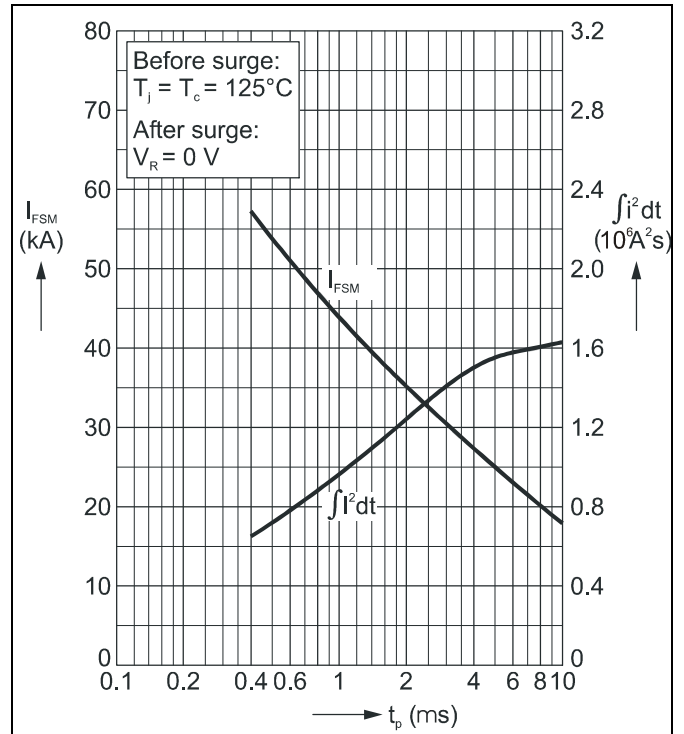

Fig. 3 Surge on-state current vs. pulse length. Half-sine wave

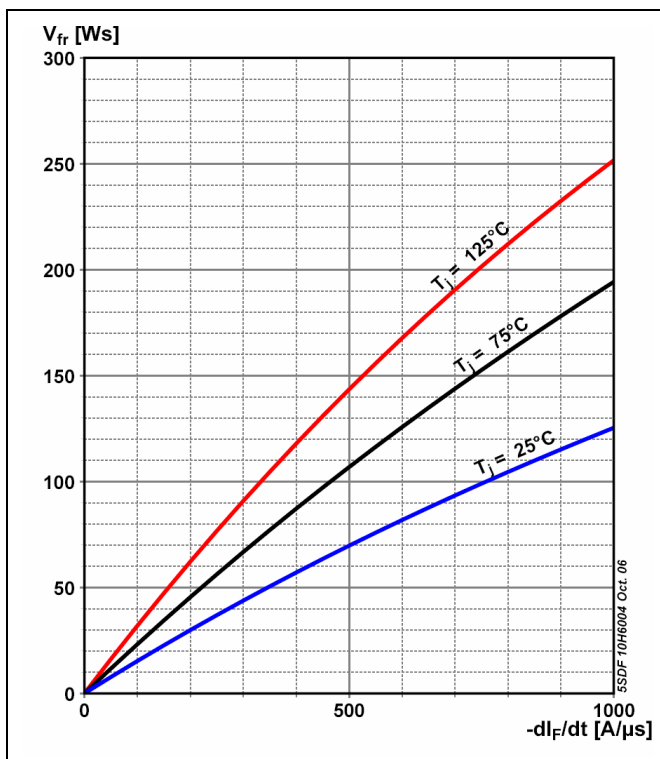

Fig. 4 Forward recovery vs. turn on  $di/dt$  (max. values)

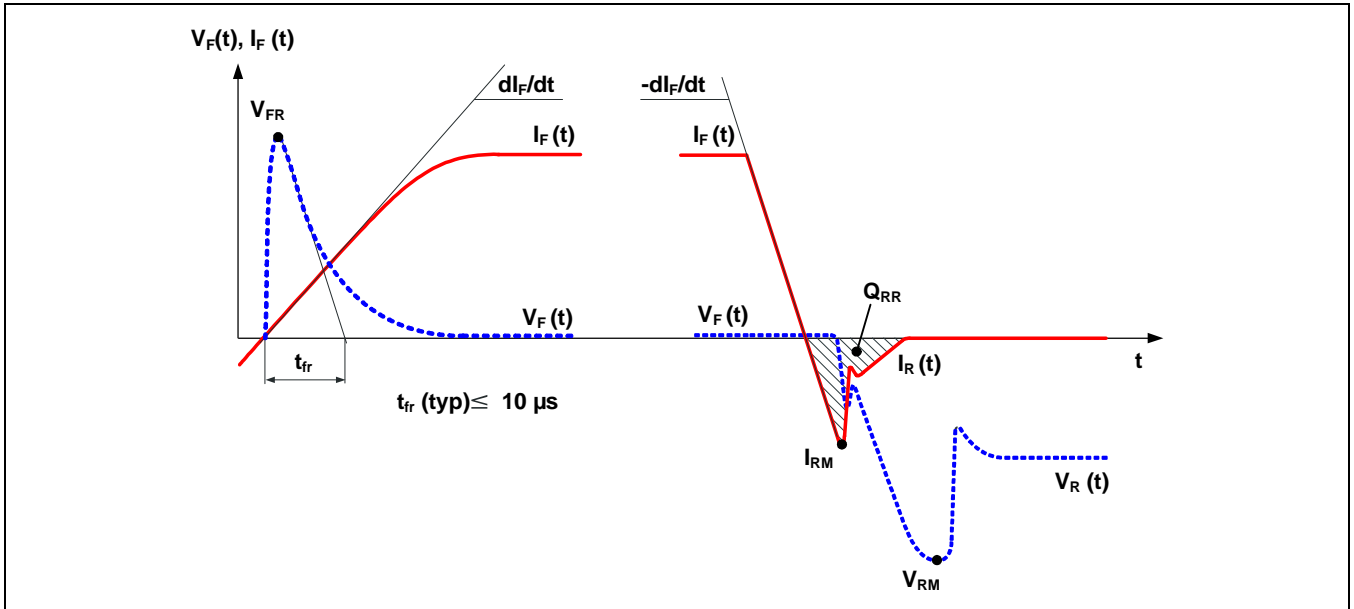

Fig. 5 General current and voltage waveforms

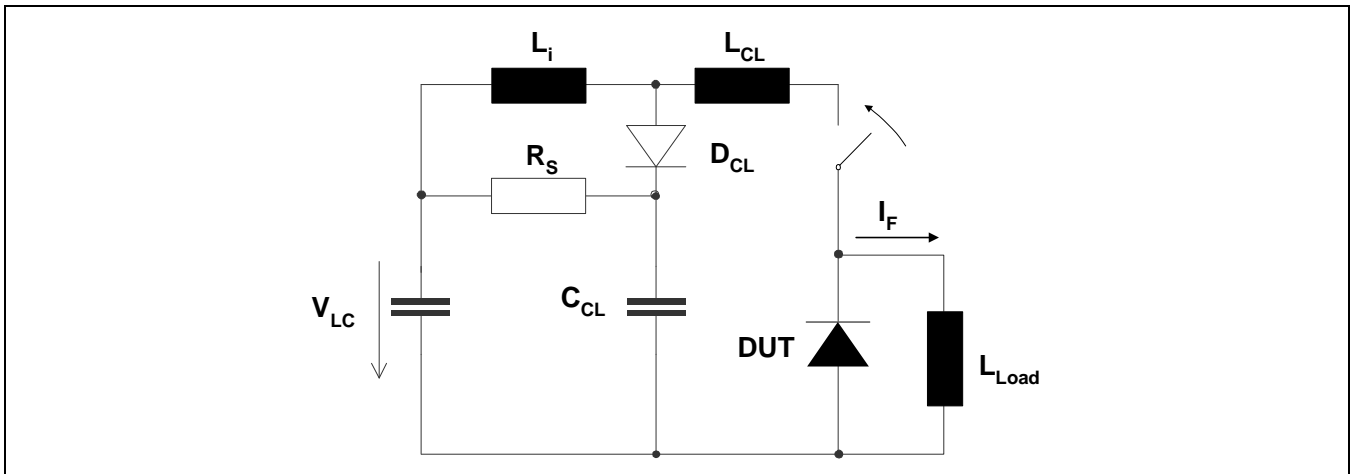
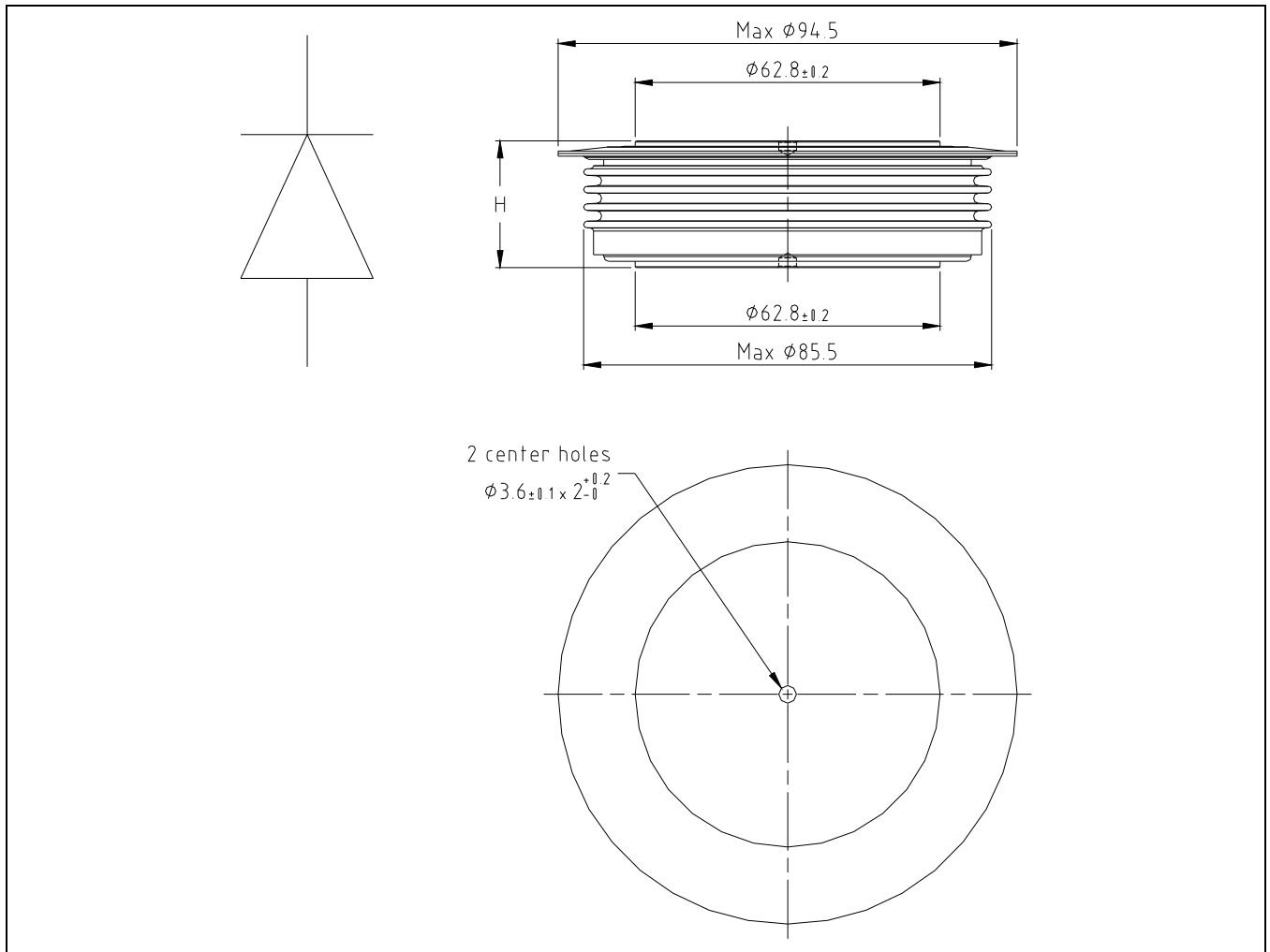

Fig. 6 Test circuit.



**Fig. 7** Outline drawing, all dimensions are in millimeters and represent nominal values unless stated otherwise

### Related documents:

Doc. Nr	Titel
5SYA 2036	Recommendations regarding mechanical clamping of Press Pack High Power Semiconductors
5SZK 9104	Specification of environmental class for pressure contact diodes, PCTs and GTO, STORAGE available on request, please contact factory
5SZK 9105	Specification of environmental class for pressure contact diodes, PCTs and GTO, TRANSPORTATION available on request, please contact factory

Please refer to <http://www.abb.com/semiconductors> for current version of documents.

ABB Switzerland Ltd, Semiconductors reserves the right to change specifications without notice.



**ABB Switzerland Ltd**  
**Semiconductors**  
 Fabrikstrasse 3  
 CH-5600 Lenzburg, Switzerland

Doc. No. 5SYA1109-02 Oct. 06

Telephone +41 (0)58 586 1419  
 Fax +41 (0)58 586 1306  
 Email [abbsem@ch.abb.com](mailto:abbsem@ch.abb.com)