



LOW POWER LOW OFFSET VOLTAGE DUAL COMPARATORS

AZ393/393C

General Description

The AZ393/393C series consists of two independent precision voltage comparators with an offset voltage specification as low as 1mV. The input common mode voltage range of these comparators includes ground, even when operated from a single power supply voltage. Operation from split power supplies is also possible and the low power supply current drain is independent of the magnitude of the power supply voltage.

The AZ393/393C series is designed to directly interface with TTL and CMOS. AZ393C has more stringent input offset voltage than AZ393.

The AZ393/393C series can be widely used in applications such as battery charger, cordless telephone, switching power supply, DC-DC module and PC motherboard.

The AZ393/393C series are available in standard packages of DIP-8 and SOIC-8.

Features

- Wide Supply Voltage Range
 - Single Supply: 2.0V to 18V
 - Dual Supplies: $\pm 1.0V$ to $\pm 9V$
- Very Low Supply Current Drain: 0.4mA
 - Independent of Supply Voltage
- Low Input Bias Current: 25nA (Typical)
- Low Input Offset Current: $\pm 5nA$ (Typical)
- Low Input Offset Voltage: $\pm 1mV$ (Typical)
- Input Common Mode Voltage Range Includes Ground
- Differential Input Voltage Range Equals to the Power Supply Voltage
- Low Output Saturation Voltage: 250mV at 4mA
- Open Collector Output

Applications

- Battery Charger
- Cordless Telephone
- Switching Power Supply
- DC-DC Module
- PC Motherboard
- Communication Equipment

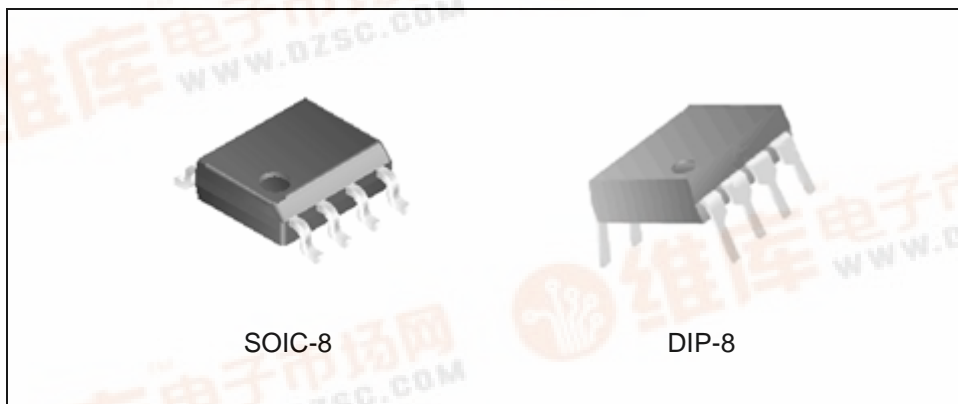

Figure 1. Package Types of AZ393/393C





LOW POWER LOW OFFSET VOLTAGE DUAL COMPARATORS

AZ393/393C

Pin Configuration

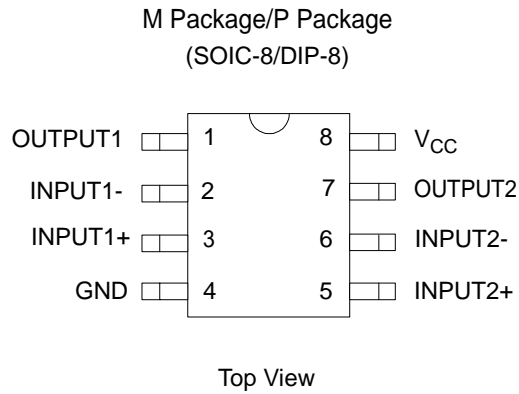

Figure 2. Pin Configuration of AZ393/393C

Functional Block Diagram

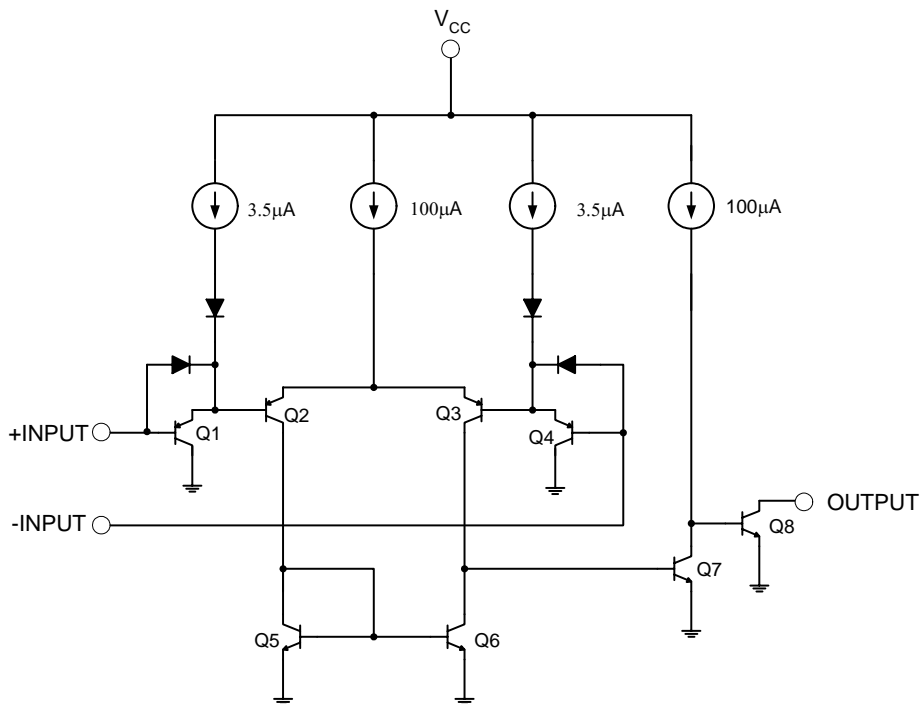
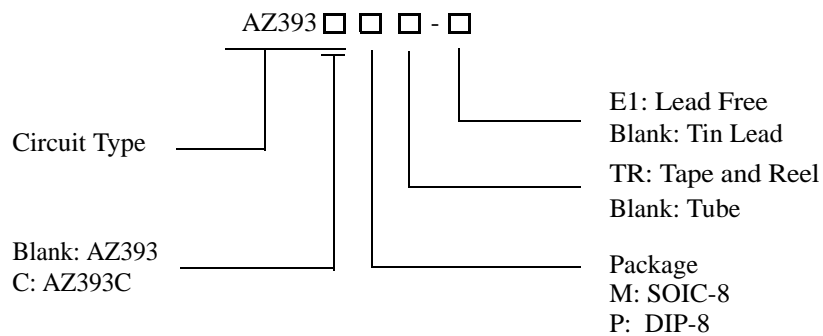

Figure 3. Functional Block Diagram of AZ393/393C
(Each Comparator)



LOW POWER LOW OFFSET VOLTAGE DUAL COMPARATORS AZ393/393C

Ordering Information



Package	Input Offset Voltage		Part Number		Marking ID		Packing Type
			Tin Lead	Lead Free	Tin Lead	Lead Free	
SOIC-8	Maximum Value	5mV	AZ393M	AZ393M-E1	AZ393M	AZ393M-E1	Tube
		5mV	AZ393MTR	AZ393MTR-E1	AZ393M	AZ393M-E1	Tape & Reel
		2mV	AZ393CM	AZ393CM-E1	393CM	393CM-E1	Tube
		2mV	AZ393CMTR	AZ393CMTR-E1	393CM	393CM-E1	Tape & Reel
DIP-8	Maximum Value	5mV	AZ393P	AZ393P-E1	AZ393P	AZ393P-E1	Tube
		2mV	AZ393CP	AZ393CP-E1	AZ393CP	AZ393CP-E1	Tube

BCD Semiconductor's Pb-free products, as designated with "E1" suffix in the part number, are RoHS compliant.

**LOW POWER LOW OFFSET VOLTAGE DUAL COMPARATORS****AZ393/393C****Absolute Maximum Ratings (Note 1)**

Parameter	Symbol	Value		Unit
Supply Voltage	V_{CC}	20		V
Differential Input Voltage	V_{ID}	20		V
Input Voltage	V_{IN}	-0.3 to 20		V
Input Current ($V_{IN} < -0.3V$) (Note 2)	I_{IN}	50		mA
Power Dissipation ($T_A=25^\circ C$)	P_D	DIP-8	780	mW
		SOIC-8	660	
Output Short Circuit to Ground		Continuous		
Operating Junction Temperature	T_J	150		$^\circ C$
Storage Temperature Range	T_{STG}	-65 to 150		$^\circ C$
Lead Temperature (Soldering, 10 seconds)	T_{LEAD}	260		$^\circ C$

Note 1: Stresses greater than those listed under "Absolute Maximum Ratings" may cause permanent damage to the device. These are stress ratings only, and functional operation of the device at these or any other conditions beyond those indicated under "Recommended Operating Conditions" is not implied. Exposure to "Absolute Maximum Ratings" for extended periods may affect device reliability.

Note 2: This input current will only exist when the voltage at any of the input leads is driven negative. It is due to the collector-base junction of the input PNP transistors becoming forward biased and thereby acting as input diode clamps. In addition to this diode action, there is also lateral NPN parasitic transistor action on the IC chip. This transistor action can cause the output voltages of the comparators to go to the $V+$ voltage level (or to ground for a large overdrive) for the time duration that an input is driven negative. This is not destructive and normal output states will re-establish when the input voltage, which was negative, again returns to a value greater than $-0.3 V_{DC}$ (at $25^\circ C$).

Recommended Operating Conditions

Parameter	Symbol	Min	Max	Unit
Supply Voltage	V_{CC}	2	18	V
Operating Temperature Range	T_A	-40	85	$^\circ C$



LOW POWER LOW OFFSET VOLTAGE DUAL COMPARATORS AZ393/393C

Electrical Characteristics

$V_{CC}=5V$, $GND=0V$, $T_A=25^{\circ}C$, unless otherwise specified.

Parameter	Conditions	Min	Typ	Max	Unit	
Input Offset Voltage	(Note 3)	AZ393		1.0	5.0	mV
		AZ393C		1.0	2.0	
Input Bias Current	I_{IN+} or I_{IN-} with output in linear range, $V_{CM}=0V$, (Note 4)		25	250	nA	
Input Offset Current	$I_{IN+}-I_{IN-}$, $V_{CM}=0V$		5.0	50	nA	
Input Common Mode Voltage Range	$V_{CC}=15V$ (Note 5)	0		$V_{CC}-1.5$	V	
Supply Current	$R_L=\infty$, $V_{CC}=5V$		0.4	1.0	mA	
	$R_L=\infty$, $V_{CC}=18V$		1.0	2.5		
Voltage Gain	$R_L \geq 15k\Omega$, $V_{CC}=15V$, $V_O=1V$ to $11V$	50	200		V/mV	
Large Signal Response Time	V_{IN} =TTL logic swing, $V_{REF}=1.4V$, $V_{RL}=5V$, $R_L=5.1k\Omega$		300		ns	
Response Time	$V_{RL}=5V$, $R_L=5.1k\Omega$, (Note 6)		1.3		μs	
Output Sink Current	$V_{IN-}=1V$, $V_{IN+}=0$, $V_O \leq 1.5V$	6.0	16		mA	
Saturation Voltage	$V_{IN-}=1V$, $V_{IN+}=0$, $I_{SINK} \leq 4mA$		250	400	mV	
Output Leakage Current	$V_{IN-}=0$, $V_{IN+}=1V$, $V_O=5V$		0.1		nA	

Note 3: At output switch point, $V_O=1.4V$, $R_S=0$ with V_{CC} from 5V to 15V, and over the full common-mode range (0V to $V_{CC}-1.5V$), at 25°C.

Note 4: The direction of the input current is out of the PNP input stage. This current is essentially constant, independent of the state of the output, so no loading charge exists on the reference of input lines.

Note 5: The input common-mode voltage of either input signal voltage should not be allowed to go negative by more than 0.3V. The upper end of the common-mode voltage range is $V_{CC}-1.5V$, but either or both inputs can go to +18V without damage, independent of the magnitude of V_{CC} .

Note 6: The response time specified is a 100mV input step with 5mV overdrive. For large overdrive signals 300ns can be obtained.



LOW POWER LOW OFFSET VOLTAGE DUAL COMPARATORS AZ393/393C

Typical Performance Characteristics

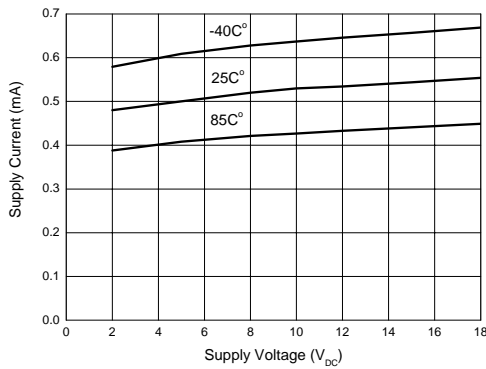

Figure 4. Supply Voltage vs. Supply Current

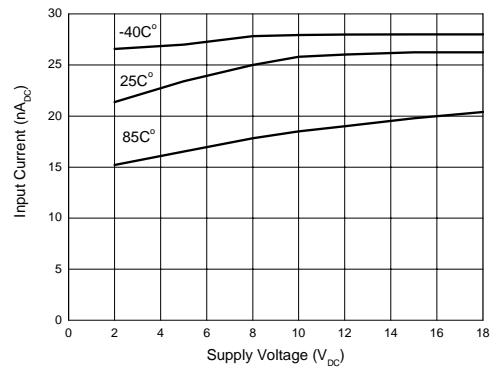

Figure 5. Supply Voltage vs. Input Current

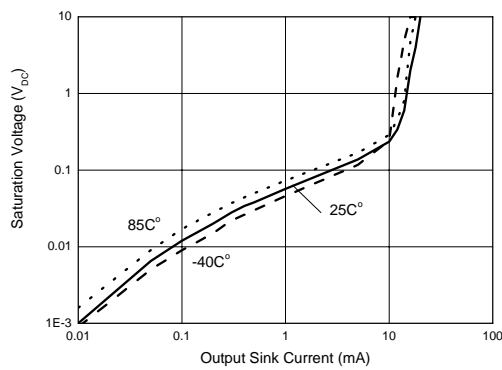

Figure 6. Output Sink Current vs. Saturation Voltage

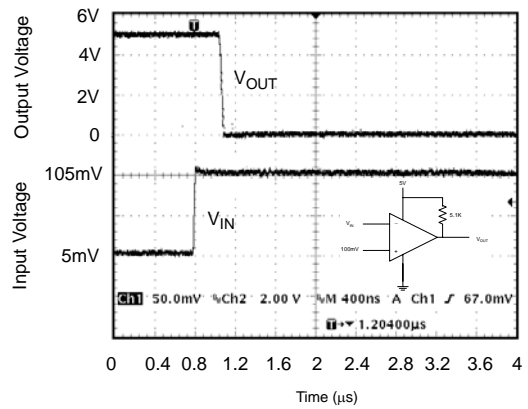

Figure 7. Response Time for 5mV Input Overdrive - Negative Transition

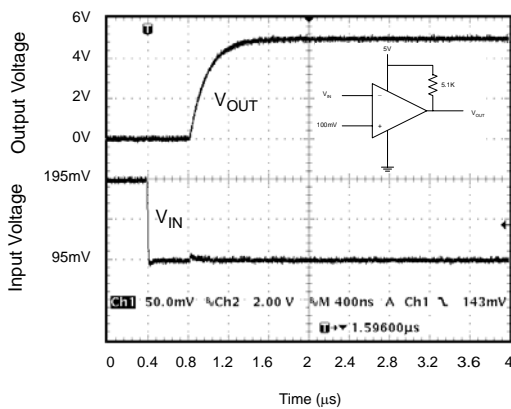

Figure 8. Response Time for 5mV Input Overdrive - Positive Transition



LOW POWER LOW OFFSET VOLTAGE DUAL COMPARATORS AZ393/393C

Typical Application

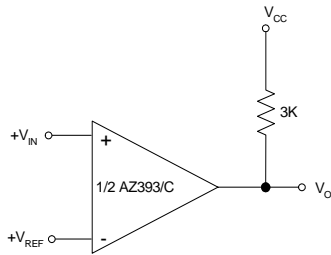

Figure 9. Basic Comparator

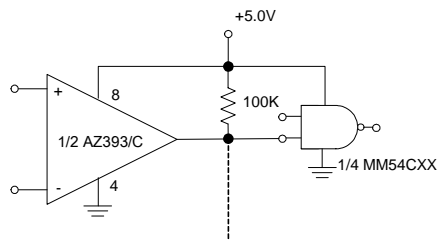

Figure 10. Driving CMOS/TTL

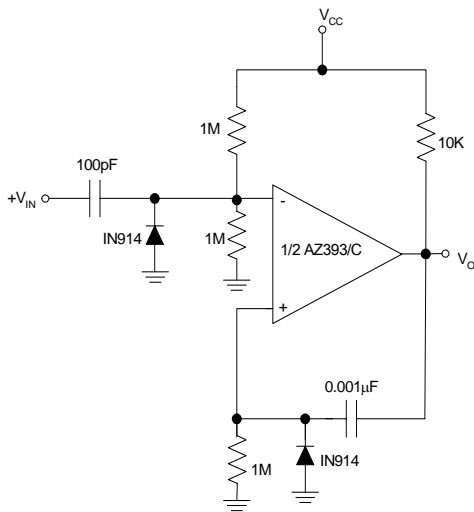

Figure 11. One Shot Multivibrator

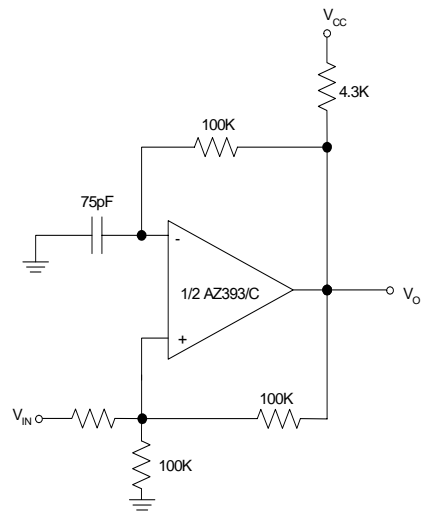

Figure 12. Squarewave Oscillator



LOW POWER LOW OFFSET VOLTAGE DUAL COMPARATORS **AZ393/393C**

Mechanical Dimensions

DIP-8

Unit: mm(inch)

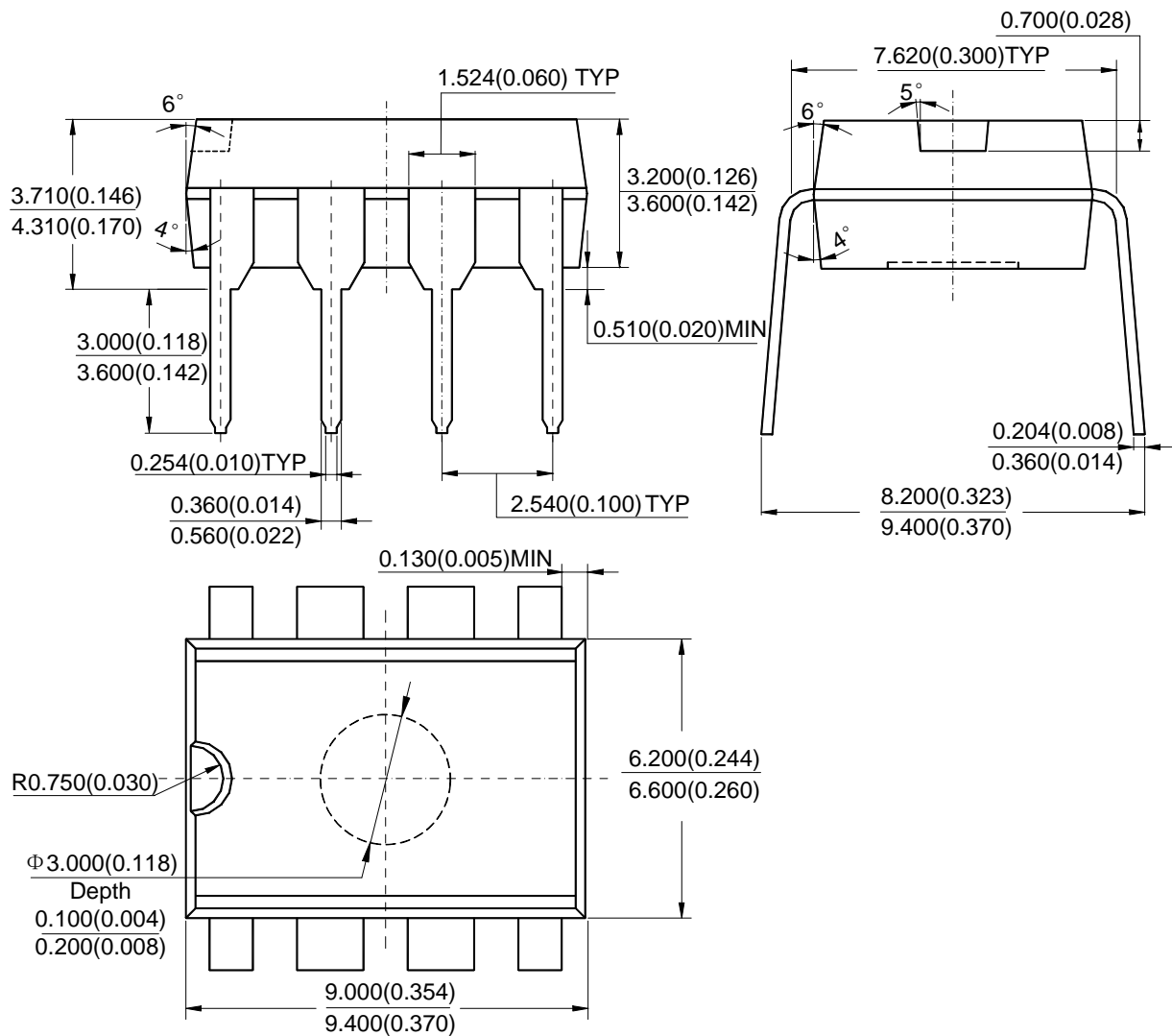



LOW POWER LOW OFFSET VOLTAGE DUAL COMPARATORS

AZ393/393C

Mechanical Dimensions (Continued)

SOIC-8

Unit: mm(inch)

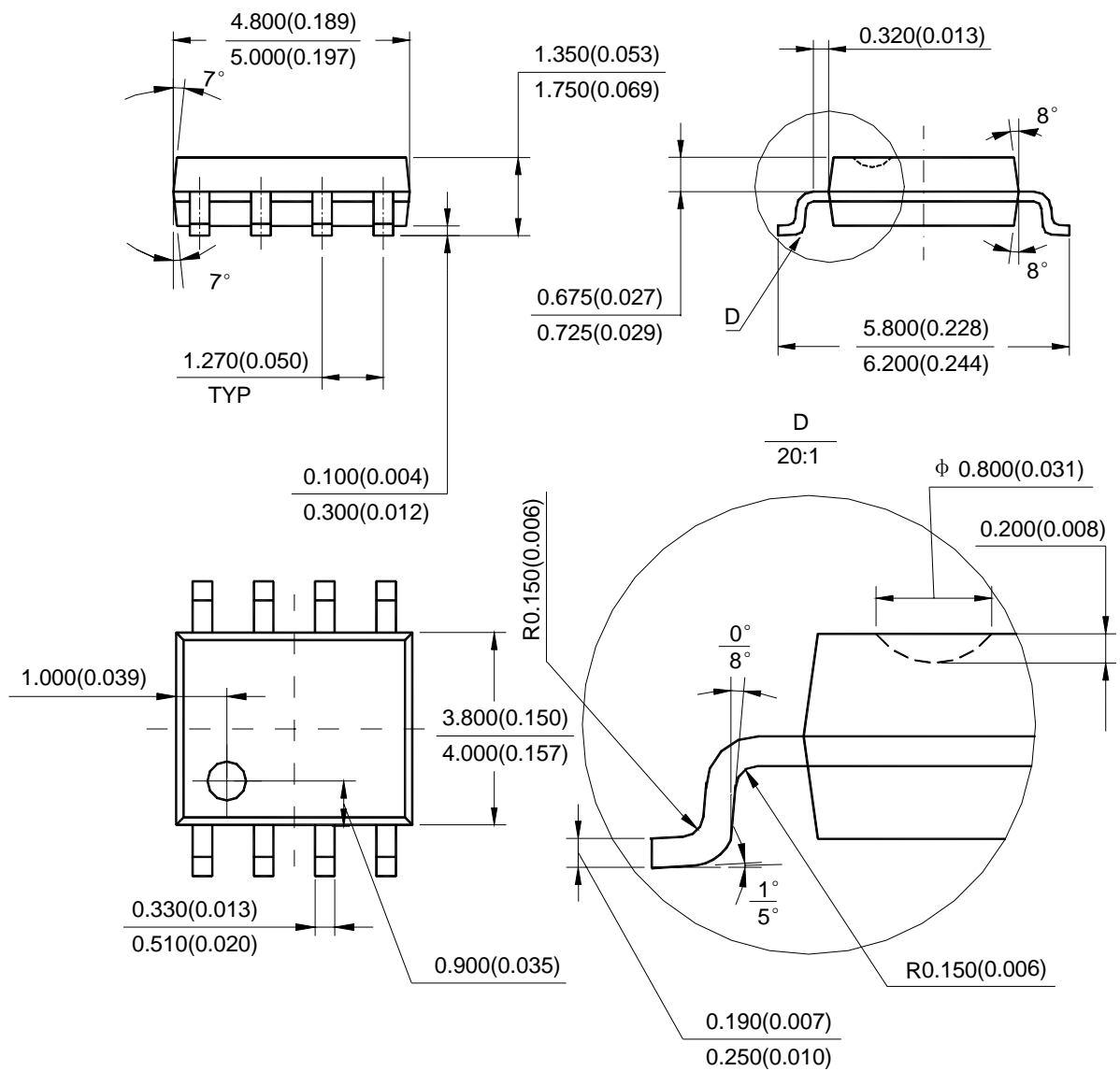



BCD Semiconductor Manufacturing Limited

<http://www.bcdsemi.com>

IMPORTANT NOTICE

BCD Semiconductor Manufacturing Limited reserves the right to make changes without further notice to any products or specifications herein. BCD Semiconductor Manufacturing Limited does not assume any responsibility for use of any its products for any particular purpose, nor does BCD Semiconductor Manufacturing Limited assume any liability arising out of the application or use of any its products or circuits. BCD Semiconductor Manufacturing Limited does not convey any license under its patent rights or other rights nor the rights of others.

MAIN SITE

BCD Semiconductor Manufacturing Limited
- Wafer Fab
Shanghai SIM-BCD Semiconductor Manufacturing Limited
800, Yi Shan Road, Shanghai 200233, China
Tel: +86-21-6485 1491, Fax: +86-21-5450 0008

BCD Semiconductor Manufacturing Limited
- IC Design Group
Advanced Analog Circuits (Shanghai) Corporation
8F, Zone B, 900, Yi Shan Road, Shanghai 200233, China
Tel: +86-21-6495 9539, Fax: +86-21-6485 9673

REGIONAL SALES OFFICE

Shenzhen Office
Shanghai SIM-BCD Semiconductor Manufacturing Co., Ltd. Shenzhen Office
Advanced Analog Circuits (Shanghai) Corporation Shenzhen Office
27B, Tower C, 2070, Middle Shen Nan Road, Shenzhen 518031, China
Tel: +86-755-8368 3987, Fax: +86-755-8368 3166

Taiwan Office
BCD Semiconductor (Taiwan) Company Limited
4F, 298-1, Rui Guang Road, Nei-Hu District, Taipei, Taiwan
Tel: +886-2-2656 2808, Fax: +886-2-2656 2806

USA Office
BCD Semiconductor Corporation
3170 De La Cruz Blvd., Suite 105, Santa Clara, CA 95054-2411, U.S.A
Tel: +1-408-988 6388, Fax: +1-408-988 6386