



AP1609

PWM/PFM DUAL MODE STEP-UP DC/DC CONVERTER

Features

- Input Voltage Range: 2.5~6V
- Output Voltage Range: 3.0~17V ($\pm 2.5\%$)
- PWM/PFM Switching Control
- Oscillator Frequency: 300KHz ($\pm 20\%$)
- High Efficiency: 91% (Typ.)
- Stand-by Current: $I_{STB} 1 = \mu A$ (Typ.)
- Built-in internal N-Channel MOS
- Lead-Free and Green Package: SOP-8L
- Lead Free Finish/RoHS Compliant for Lead Free products (Note 1)

General Description

The AP1609 is a high efficient step-up DC/DC converter. Large output current is possible having a built in internal N channel MOSFET, and using an external coil and diode.

Output voltage is programmable with 1.23V of standard voltage supply internal, and using externally connected components, output voltage (FB) can be set up at will.

With a 300KHz switching frequency, the size of the external components can be reduced. Control switches from PFM to PWM during light loads with the AP1609 (PWM/PFM switchable) and the series are highly efficient from light loads to large output currents.

During stand-by time (CE pin "Low"), current consumption is reduced to 1 μA .

Applications

- Electronic Information Organizers
- Palmtops
- Cellular and Portable Phones
- Portable Audio Systems
- Various Multi-Function Power Supplies

Ordering Information

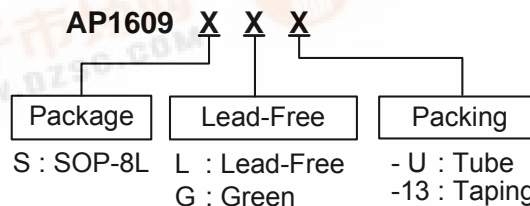

Note: 1. RoHS revision 13.2.2003. Glass and High Temperature Solder Exemptions Applied, see *EU Directive Annex Notes 5 and 7*.

Device (Note 2)	Package Code	Packaging	Tube		13" Tape and Reel	
			Quantity	Part Number Suffix	Quantity	Part Number Suffix
AP1609S	S	SOP-8L	100	-U	2500/Tape & Reel	-13

Note: 2. Pad layout as shown on Diodes Inc. suggested pad layout document AP02001, which can be found on our website at <http://www.diodes.com/datasheets/ap02001.pdf>.

Pin Assignments

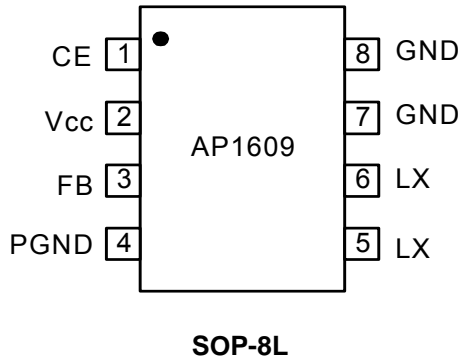

Pin Descriptions

Pin Name	Pin Number	Description
CE	1	Chip Enable: H: Enable L: Disable
V _{CC}	2	IC signal power supply pin
FB	3	Feedback pin
PGND	4	Power MOSFET GND
LX	5, 6	Switch Pin. Connect external inductor/diode here. Minimize trace area at this pin to reduce EMI.
GND	7, 8	GND Pin

Block Diagram

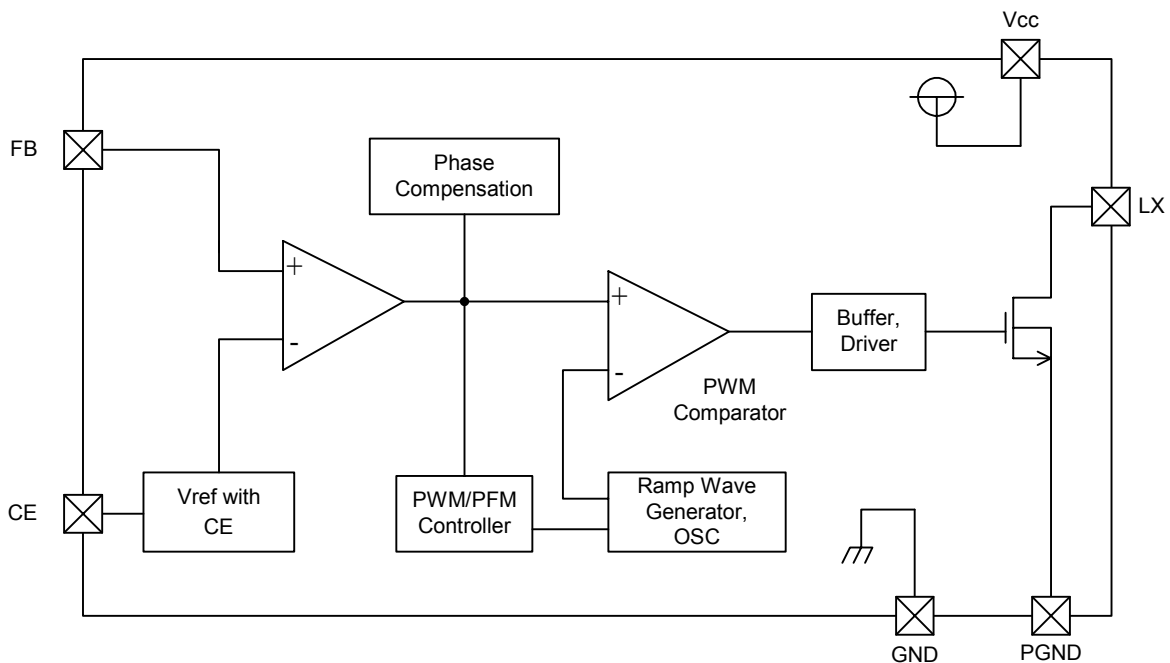

Absolute Maximum Ratings

Parameter	Symbol	Ratings	Units
V _{IN} Pin Voltage	V _{CC}	-0.3 ~ 7	V
FB Pin Voltage	V _{FB}	-0.3 ~ V _{CC} +0.3	V
CE Pin Voltage	V _{CE}	-0.3 ~ V _{CC} +0.3	V
Switch Voltage (LX to GND)	V _{SW}	-0.3 ~ 18	V
Switch Current	I _{LX}	-3 ~ 0.2	A
Continuous Total Power Dissipation	P _d	1200	mW
Operating Ambient Temperature	T _{opr}	-20 ~ +80	°C
Storage Temperature	T _{stg}	-20 ~ +125	°C

Electrical Characteristics

AP1609

 (F_{OSC} = 300kHz, V_{OUT} = 5V)

 T_a = 25 °C

Parameter	Symbol	Conditions	Min.	Typ.	Max.	Units
FB Voltage	V _{FB}		1.20	1.23	1.26	V
Input Voltage	V _{CC}		2.5	-	6	V
Output Voltage	V _{OUT}		3.0	-	17	V
Maximum Switching Output Current	I _{OUT}		2.4	-	-	A
Drain-Source On-State Resistance	R _{DS(ON)}	I _D = 2.4A	-	100	-	mΩ
Quiescent Current	I _{CCQ}	No Load, FB = 2V, CE = High	-	80	130	μA
Shutdown Current	I _{SD}	No Load, CE = Low	-	1	-	μA
Oscillator Frequency	F _{osc}	Measuring of EXT Waveform, V _{IN} = Output Voltage +0.3V	240	300	360	kHz
Maximum Duty Ratio	MAXDTY		80	-	-	%
PFM Duty Ratio	PFMDTY	No Load	15	25	35	%
CE "High" Voltage	V _{CEH}	No External Components, V _{FB} = 0V, Apply 0.65V _{CC} (min.) to CE, Chip Enable	0.65	-	-	*V _{CC}
CE "Low" Voltage	V _{CEL}	Same as V _{CEH} , Chip Disable	-	-	0.20	*V _{CC}
Efficiency	EFFI		-	91	-	%

Typical Application Circuit

(1) Normal Circuit

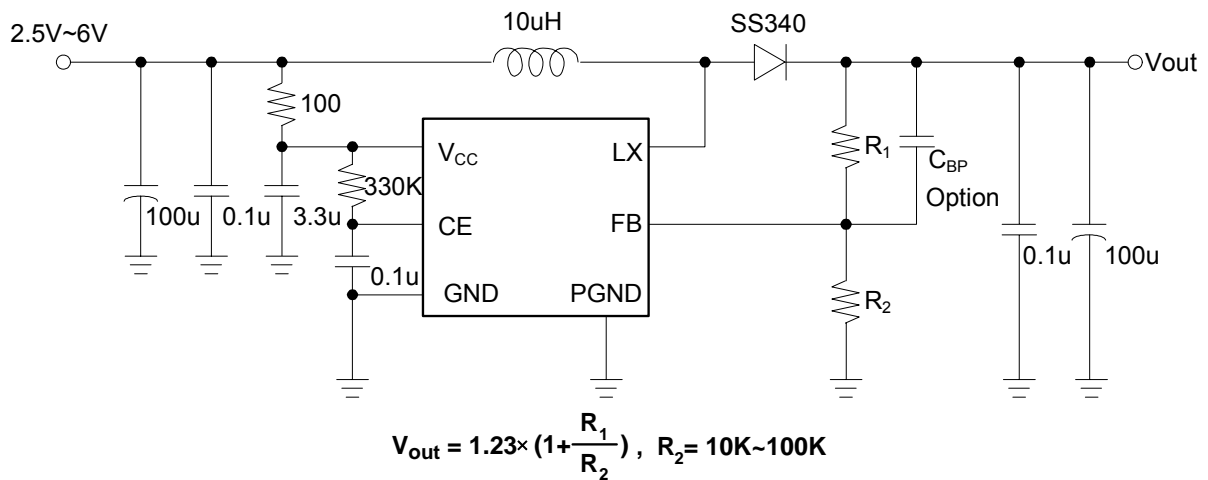

(2) HV Circuit

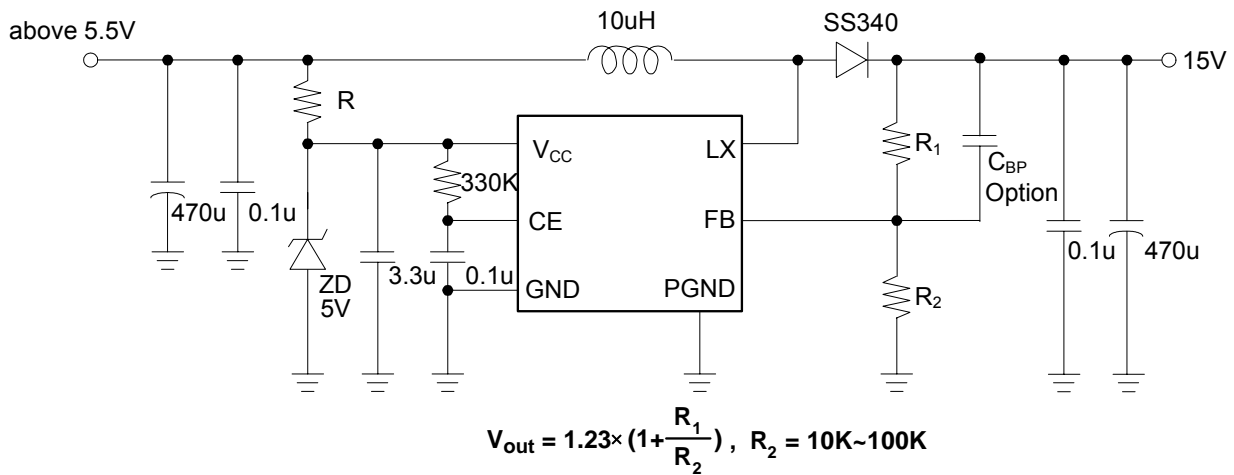

Typical Performance Characteristics

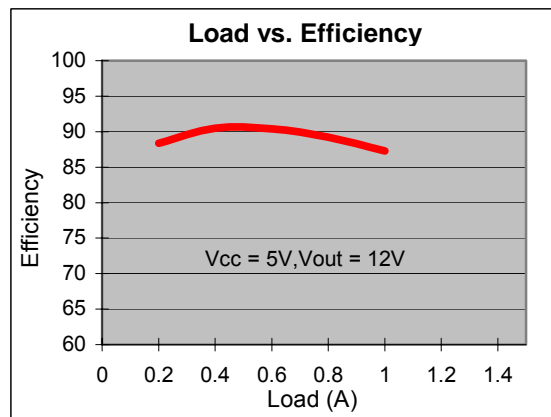
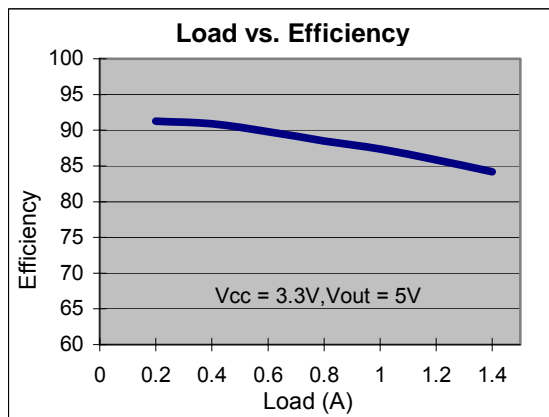
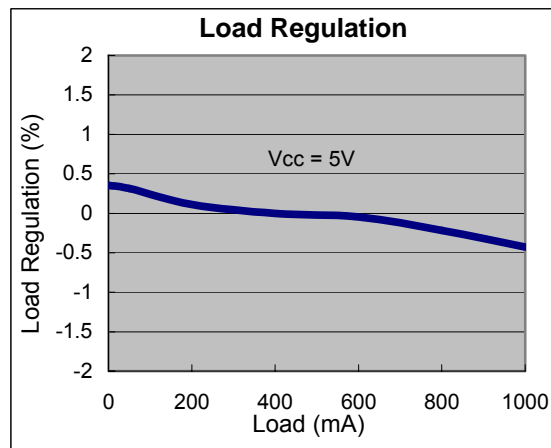
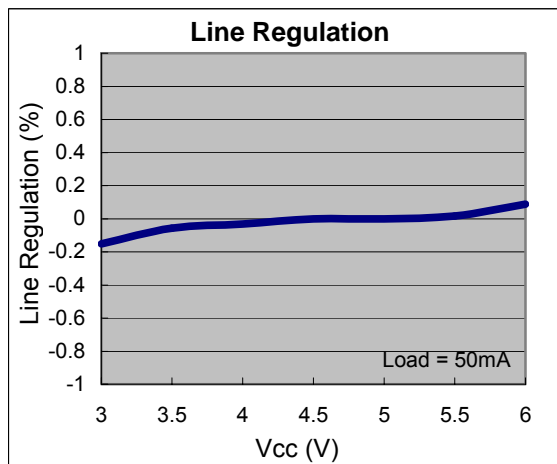
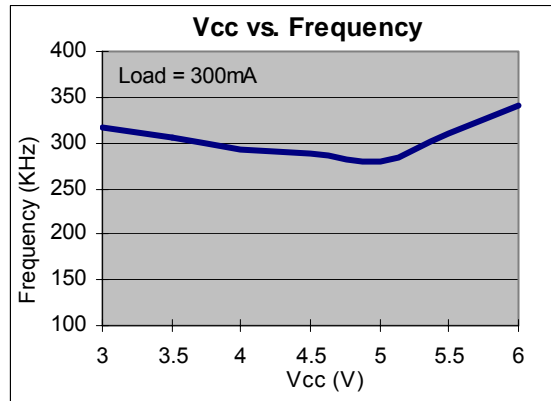
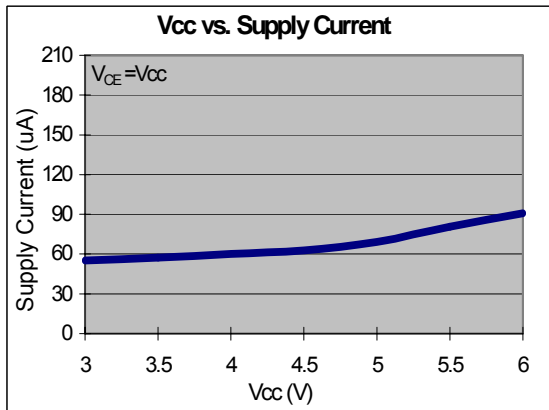

Typical Performance Characteristics (Continued)

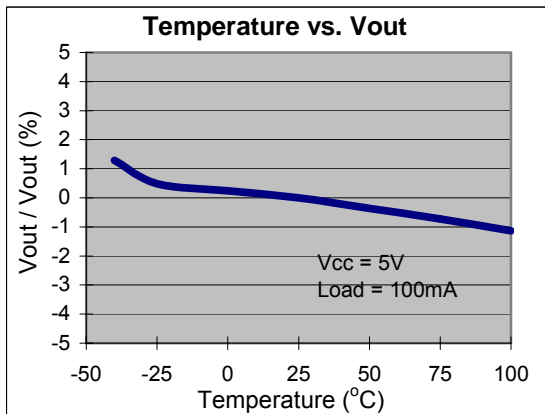
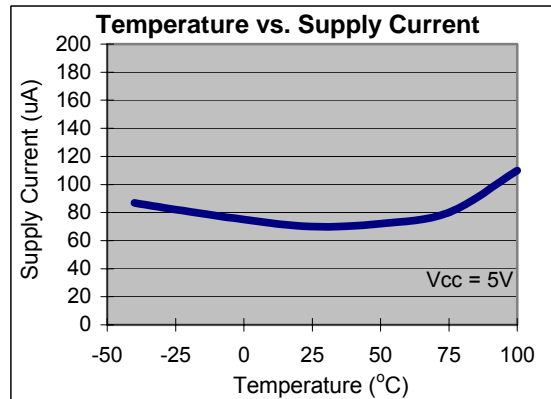
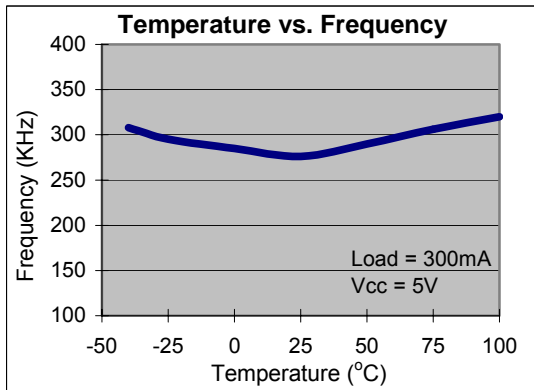

Marking Information

(1) SOP-8L

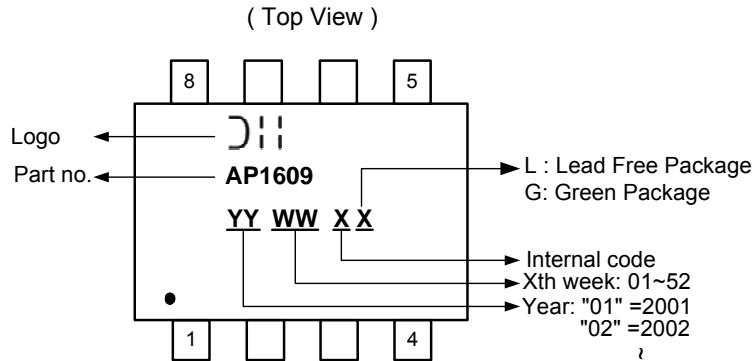

Device	Package	Identification Code
AP1609S	SOP-8L	AP1609

Package Information (All Dimensions in mm)

Package Type: SOP-8L

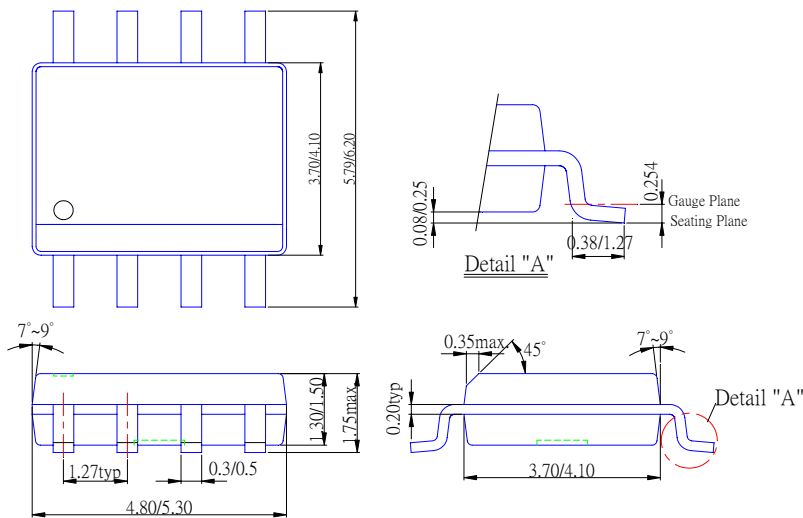

IMPORTANT NOTICE

Diodes Incorporated and its subsidiaries reserve the right to make modifications, enhancements, improvements, corrections or other changes without further notice to any product herein. Diodes Incorporated does not assume any liability arising out of the application or use of any product described herein; neither does it convey any license under its patent rights, nor the rights of others. The user of products in such applications shall assume all risks of such use and will agree to hold Diodes Incorporated and all the companies whose products are represented on our website, harmless against all damages.

LIFE SUPPORT

Diodes Incorporated products are not authorized for use as critical components in life support devices or systems without the expressed written approval of the President of Diodes Incorporated.