



# ACT4088

Rev PrA, 24-Jul-07

Advanced Product Information – All Information Subject to Change

## 28V, 1.5A, 1.4MHz Step-Down DC/DC Converter in SOT23-6

### FEATURES

- Wide 4.5V to 28V Input Voltage Range
- 1.5A Output Current (12V<sub>IN</sub> to 5V<sub>OUT</sub>)
- Output Adjustable Down to 0.81V
- 0.3Ω Internal Power MOSFET
- Up to 92% Efficiency
- Stable with Low ESR Ceramic Output Capacitors
- Fixed 1.4MHz Operating Frequency
- Internal Soft-Start Function
- Over Current Protection with Hiccup-Mode
- Thermal Shutdown
- Available in a SOT23-6 Package

### APPLICATIONS

- TFT LCD Monitors
- Portable DVDs, Headphones, MP3 Players, etc.
- Car-Powered or Battery-Powered Equipment
- Set-Top Boxes
- Telecom Power Supplies
- DSL and Cable Modems and Routers

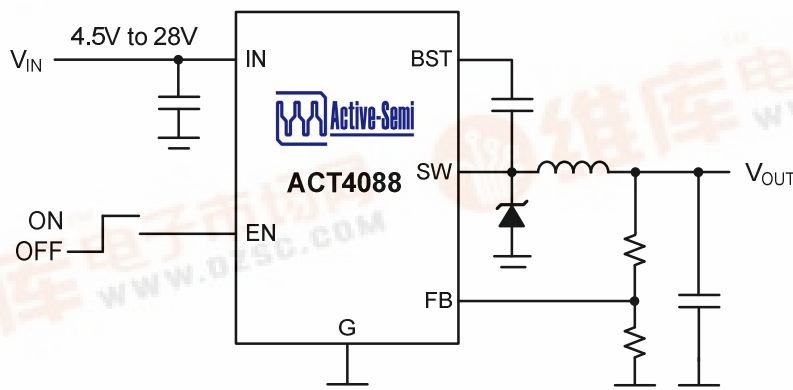
### GENERAL DESCRIPTION

The ACT4088 is a current-mode step-down DC/DC converter that supplies up to 1.5A into 5V from a 12V input. 1.4MHz switching frequency allows the use of tiny external components, and internal loop compensation provides simple, stable power supplies with a minimum of external components. Optimized for use with ceramic input and output capacitors, the ACT4088 provides a very compact 1.5A power supply for space constrained mobile and consumer applications.

The ACT4088 operates over a wide input voltage range and utilizes current-mode operation to provide excellent line and load transient response while requiring no external compensation components. Fault protection includes cycle-by-cycle current limiting, frequency fold-back, hiccup mode, and thermal shutdown. Internal soft-start provides a controlled startup with no overshoot, even at light loads.

The ACT4088 is available in a tiny SOT23-6 package and requires very few external components.

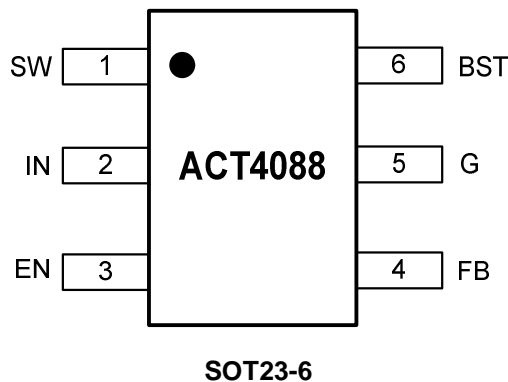
### TYPICAL APPLICATION CIRCUIT



## ORDERING INFORMATION

PART NUMBER	TEMPERATURE RANGE	PACKAGE	PINS	PACKING
ACT4088US-T	-40°C to 85°C	SOT23-6	6	TAPE & REEL

## PIN CONFIGURATION



## PIN DESCRIPTIONS

PIN NUMBER	PIN NAME	PIN DESCRIPTION
1	SW	Switch Output. Connect this pin to the switching end of the inductor.
2	IN	Power supply input. Bypass this pin with a 10 $\mu$ F ceramic capacitor to G, placed as close to the IC as possible.
3	EN	Enable Input. EN is pulled up to 5V with a 2 $\mu$ A current, and contains a precise 1.24V logic threshold. Drive this pin to a logic-high or leave unconnected to enable the IC. Drive to a logic-low to disable the IC and enter micro-power shutdown mode.
4	FB	Feedback Input. The voltage at this pin is regulated to 0.81V. Connect to the center point of a resistive voltage-divider between OUT and G to set the output voltage.
5	G	Ground and Heat sink. Connect this pin to a large, uncovered PCB copper area for best heat dissipation.
6	BST	Bootstrap. This pin acts as the power supply for the high-side switch's gate driver. Connect a 2.2nF capacitor between this pin and SW.

## ABSOLUTE MAXIMUM RATINGS<sup>①</sup>

PARAMETER	VALUE	UNIT
IN Supply Voltage	-0.3 to 32	V
SW Voltage	-1 to $V_{IN} + 1$	V
BST Voltage	$V_{SW} - 0.3$ to $V_{SW} + 7$	V
EN, FB Voltage	-0.3 to 6	V
Continuous SW Current	Internally Limited	A
Junction to Ambient Thermal Resistance ( $\theta_{JA}$ )	220	°C/W
Maximum Power Dissipation	0.5	W
Operating Junction Temperature	-40 to 150	°C
Storage Temperature	-55 to 150	°C
Lead Temperature (Soldering, 10 sec)	300	°C

①: Do not exceed these limits to prevent damage to the device. Exposure to absolute maximum rating conditions for long periods may affect device reliability.

## ELECTRICAL CHARACTERISTICS

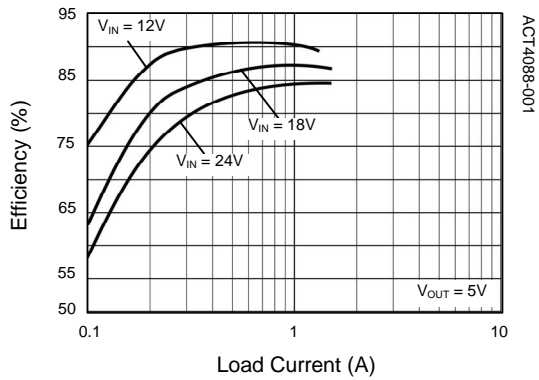
( $V_{IN} = 12V$ ,  $T_A = 25^\circ C$ , unless otherwise specified.)

PARAMETER	SYMBOL	TEST CONDITIONS	MIN	TYP	MAX	UNIT
Input Voltage	$V_{IN}$	$V_{OUT} = 3.3V$ , $I_{LOAD} = 0A$ to $1.5A$	4.5		28	V
Under Voltage Lockout Voltage	$V_{UVLO}$	Input Voltage Rising	4	4.2	4.49	V
Under Voltage Lockout Hysteresis				250		mV
Feedback Voltage	$V_{FB}$	$4.75V \leq V_{IN} \leq 20V$ , $V_{COMP} = 1.5V$	0.79	0.81	0.83	V
Frequency Foldback Threshold				250		mV
High-side Switch On Resistance	$R_{ONH}$			0.300		$\Omega$
Low-side Switch On Resistance	$R_{ONL}$			15		$\Omega$
SW Leakage		$V_{EN} = 0$ , $V_{SW} = 0V$		1	10	$\mu A$
Current Limit	$I_{LTM}$	$V_{IN} = 12V$ , $V_{OUT} = 5V$ , or $EN = G$ , $SW = G$		1.8		A
Switching Frequency	$f_{SW}$		1.2	1.4	1.7	MHz
Foldback Switching Frequency		$V_{FB} = 0V$ , or $FB = G$		467		kHz
Maximum Duty Cycle	$D_{MAX}$	$V_{FB} = 0.6V$		92		%
Minimum On-Time				75		ns
EN Threshold Voltage		EN Rising	1.12	1.24	1.36	V
EN Hysteresis		EN Rising		100		mV
EN Internal Pull-up Current				2		$\mu A$
Supply Current in Shutdown		$V_{EN} = 0V$ or $EN = G$		15	30	$\mu A$
Supply Current in Operation		$V_{EN} = 2V$ , $V_{FB} = 1.0V$		1	2	mA
Thermal Shutdown Temperature				160		°C
Thermal Shutdown Hysteresis				10		°C

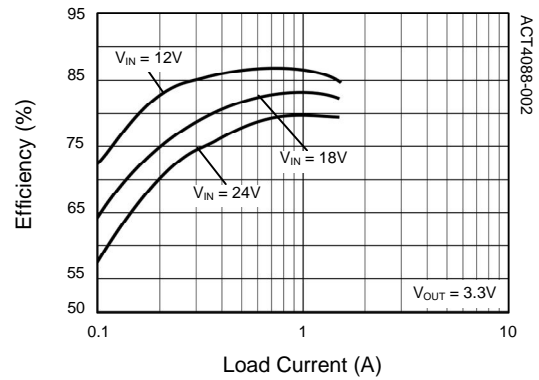
## TYPICAL PERFORMANCE CHARACTERISTICS

(Circuit of Figure 2,  $V_{IN} = 12V$ ,  $L = 4.7\mu H$ ,  $C1 = 10\mu F$ ,  $C2 = 22\mu F$ ,  $T_A = +25^\circ C$ , unless otherwise specified.)

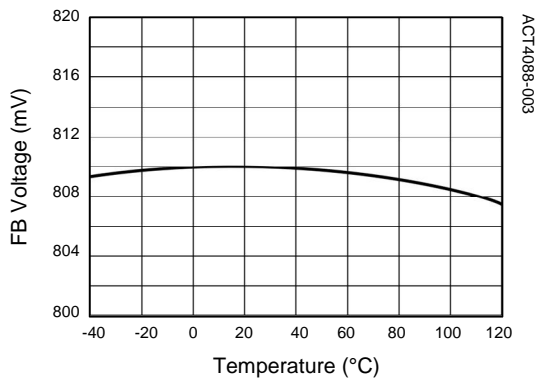
Efficiency vs. Load Current



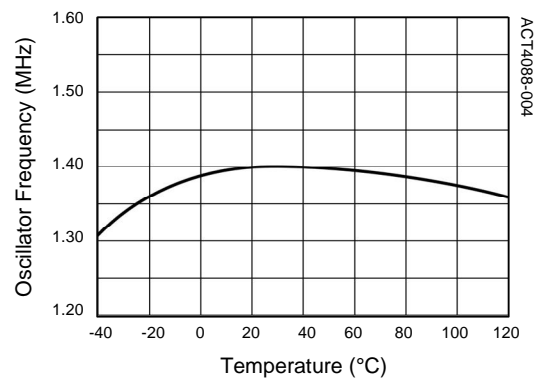
Efficiency vs. Load Current



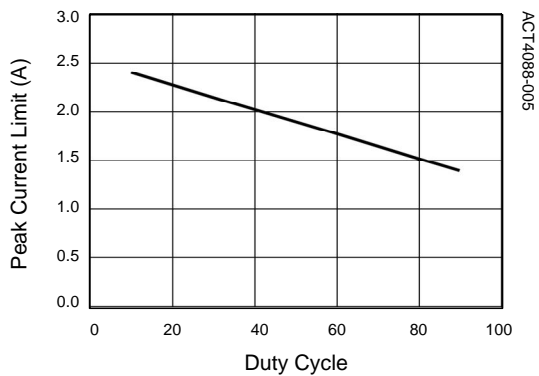
FB Voltage vs. Temperature



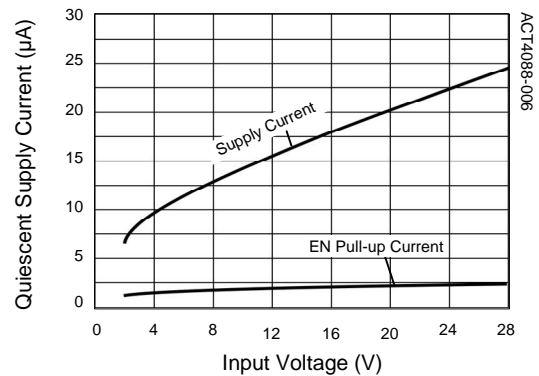
Oscillator Frequency vs. Temperature



Peak Current Limit vs. Duty Cycle



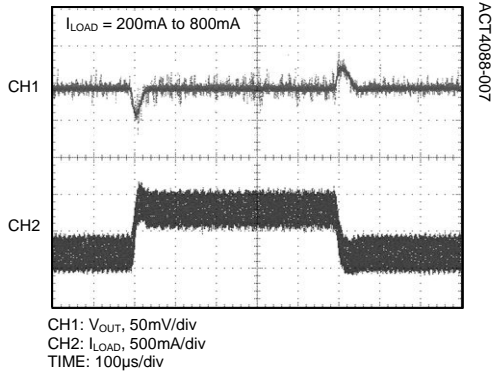
Shutdown Current vs. Input Voltage



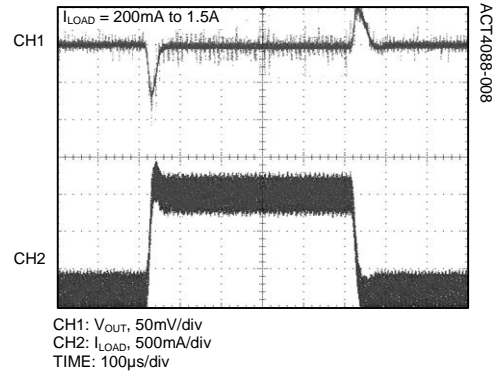
## TYPICAL PERFORMANCE CHARACTERISTICS CONT'D

(Circuit of Figure 2,  $V_{IN} = 12V$ ,  $L = 4.7\mu H$ ,  $C1 = 10\mu F$ ,  $C2 = 22\mu F$ ,  $T_A = +25^\circ C$ , unless otherwise specified.)

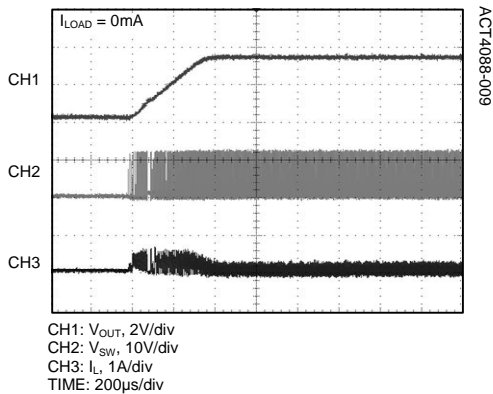
**Load Transient Response**



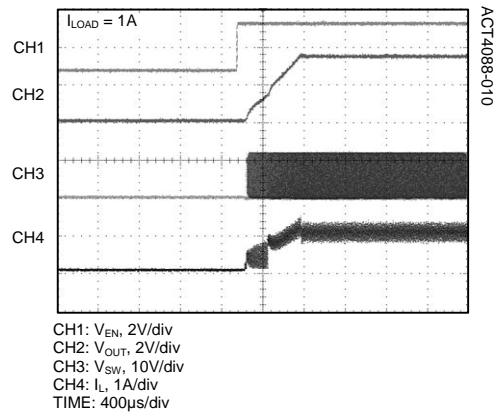
**Load Transient Response**



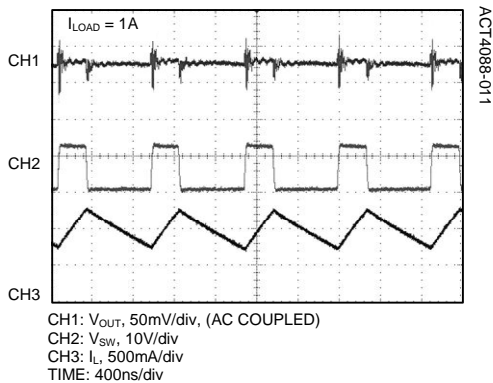
**Start-up Waveforms**



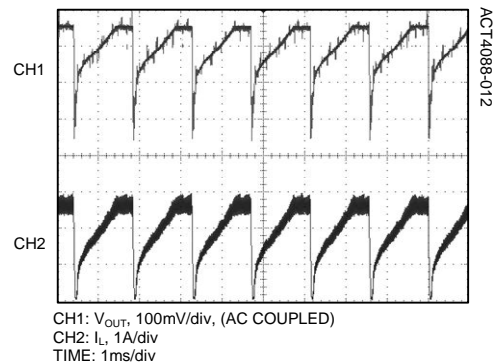
**Start-up Waveforms**



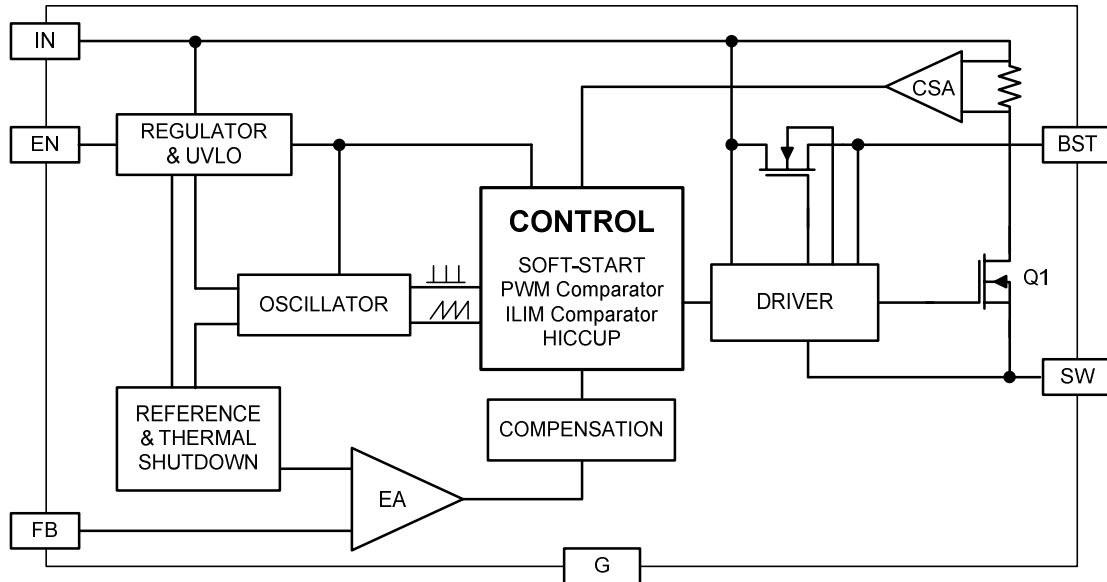
**Steady State Switching Waveforms**



**Hiccup Mode Switching Waveforms**



## FUNCTIONAL BLOCK DIAGRAM



## FUNCTIONAL DESCRIPTION

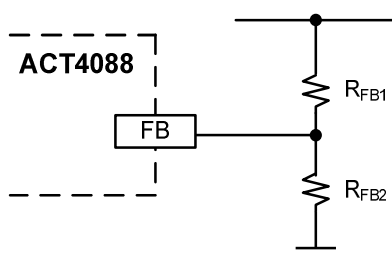
The ACT4088 is a current-mode step-down DC/DC converter that provides excellent transient response with no extra external compensation components. This device contains an internal, low-resistance, high-voltage power MOSFET, and operates at a high 1.4MHz operating frequency to ensure a compact, high-efficiency design with excellent AC and DC performance.

### Setting the Output Voltage

An external voltage divider is used to set the output voltage, as well as provide a known impedance from  $V_{OUT}$  to FB for compensation purposes. Connect a 50kΩ resistor from the output to FB to ensure stable compensation, and select the bottom resistor to provide the desired regulation voltage.

Figure 1:

### Output Voltage Setting



The feedback resistor ( $R_{FB1}$ ) interacts with the internal compensation network, and plays an important

in setting the ACT4088's transient response and ensuring stability. For most applications, choosing  $R_{FB1} = 49.9k\Omega$  provides good results. For applications with output voltages of 1.8V or lower, use a larger  $R_{FB1}$  value such as 80.6kΩ. Once  $R_{FB1}$  is chosen, use the following equation to choose  $R_{FB2}$ :

$$R_{FB2} = \frac{R_{FB1}}{\left(\frac{V_{OUT}}{0.81V} - 1\right)} \quad (1)$$

### Selecting the Inductor

The ACT4088 was optimized for use with a 4.7μH inductor. When choosing an inductor, choose one with a DC resistance of less than 250mΩ and a DC current rating that is typically 30% higher than the maximum load current.

During typical operation, the inductor maintains a continuous current to output load. The inductor current has a ripple that is dependent on the inductance value.

Higher inductance reduces the peak-to-peak ripple current. The trade off for high inductance value is the increase in inductor core size and series resistance, and a reduction in current handling capability.

If efficiency at light loads (such as less than 100mA) is critical in the application, a larger inductor is recommended.



## Rectifier Diode

Use a Schottky diode as the rectifier to conduct current when the High-Side Power Switch is off. The Schottky diode must have current rating higher than the maximum output current and the reverse voltage rating higher than the maximum input voltage (see Figure 2).

## Selecting the Input Capacitor

For best performance choose a ceramic type capacitor with X5R or X7R dielectrics due to their low ESR and small temperature coefficients. However, low ESR tantalum or electrolytic types may also be used, provided that the RMS ripple current rating is higher than 50% of the output current. For most applications, a 10 $\mu$ F capacitor is sufficient. The input capacitor should be placed close to the IN and G pins of the IC, with shortest possible traces. In the case of tantalum or electrolytic types, connect a small parallel 0.1 $\mu$ F ceramic capacitor right next to the IC.

## Selecting the Output Capacitor

A 22 $\mu$ F ceramic capacitor with X5R or X7R dielectric provides the best results over a wide range of applications.

The output capacitor also needs to have low ESR to keep low output voltage ripple. The output ripple voltage is:

$$V_{\text{RIPPLE}} = I_{\text{OUTMAX}} K_{\text{RIPPLE}} R_{\text{ESR}} + \frac{V_{\text{IN}}}{8 \times f_{\text{SW}}^2 L C_{\text{OUT}}} \quad (2)$$

where  $I_{\text{OUTMAX}}$  is the maximum output current,  $K_{\text{RIPPLE}}$  is the ripple factor (typically 20% to 30%),  $R_{\text{ESR}}$  resistance is the ESR of the output capacitor,  $f_{\text{SW}}$  is the switching frequency, L is the inductor value, and  $C_{\text{OUT}}$  is the output capacitance.

In the case of ceramic output capacitors,  $R_{\text{ESR}}$  is very small and does not contribute to the ripple. In the case of tantalum or electrolytic type, the ripple is dominated by  $R_{\text{ESR}}$  multiplied by the ripple current. In that case, the output capacitor is chosen to have sufficiently low due to ESR, typically choose a capacitor with less than 50m $\Omega$  ESR.

## External Bootstrap Diode

An external bootstrap diode (D2 in Figure 2) is recommended if the input voltage is less than 5.5V or if there is a 5V system rail available. This diode helps strengthen gate drive at lower input voltages, resulting in lower on-resistance and higher efficiency. Low cost diodes, such as 1N4148 or BAT54, are suitable for this application.

## Shutdown Control

The ACT4088 enable pin provides several features for adjusting and sequencing the power supply. An internal 2 $\mu$ A current source pull-up, and a precision 1.24V comparator with hysteresis. With these components, a user has the flexibility of using the EN pin as:

- 1) A digital on/off control by pulling down the EN current source with an external open-drain transistor. The voltage at EN is internally clamped to 6V.
- 2) A sequenced power supply by tying the EN pin through a resistor to the output of another power supply. The IC will be enabled when the voltage at EN exceeds 1.24V, or a resistor divider can be used to adjust the turn-on threshold.
- 3) An always-on converter by floating the EN pin or pulling EN to a desired voltage with a high value (1M $\Omega$ ) external resistor. EN is internally clamped at 6V and will dissipate power if an external resistor attempts to pull EN above the 6V clamp voltage.
- 4) Line UVLO. If desired, to achieve a UVLO voltage that is higher than the internal UVLO, an external resistor divider from VIN to EN to GND can be used to disable the ACT4088 until a higher input voltage is achieved. For example, it is not useful for a converter with 9V output to start up with a 4.2V input voltage, as the output cannot reach regulation. To enable the ACT4088 when the input voltage reaches 12V, a 9k $\Omega$ /1k $\Omega$  resistor divider from IN to GND can be connected to the EN pin. Both the precision 1.2V threshold and 80mV hysteresis are multiplied by the resistor ratio, providing a proportional 6.67% hysteresis for any startup threshold. For the example of a 12V enable threshold, the turn off threshold would be 11.2V.
- 5) Power supply sequencing. By connecting a small capacitor from EN to GND, the 2 $\mu$ A current source and 1.24V threshold can provide a stable and predictable delay between startup of multiple power supplies. For example, a startup delay of roughly 10mS is provided using 150nF, and roughly 20mS by using 330nF. The EN current source is active anytime an input supply is applied, so disabling the IC or resetting the delay requires an external open-drain pull-down device to reset the capacitor and hold the EN pin low for shutdown.

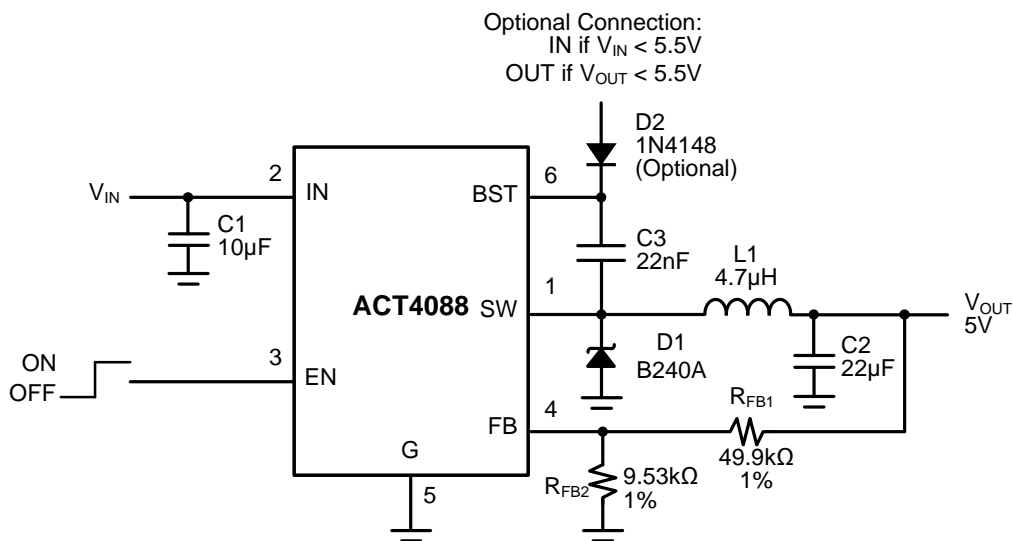
## Soft-Start

The ACT4088 provides an internal soft-start feature, which ramps the output voltage and output current from 0 to the full value over 0.5 milliseconds. This feature prevents output voltage overshoot at light loads as well as to prevent large in-rush currents upon startup. The soft-start circuitry is internally reset anytime the IC is disabled using the EN pin, as well as if the IC reaches hiccup mode or thermal shutdown. In all of these cases, soft-start provides a smooth, controlled restart after the fault is removed.

## Frequency Foldback

The voltage at FB is monitored by a comparator to detect an extreme output overload condition. If the voltage at the FB pin falls to below 0.3V, the internal oscillator slows to a decreased frequency of 467kHz, 33% of the nominal value. This prevents the inductor current from rising excessively during a dead-short condition, potentially resulting in inductor saturation.

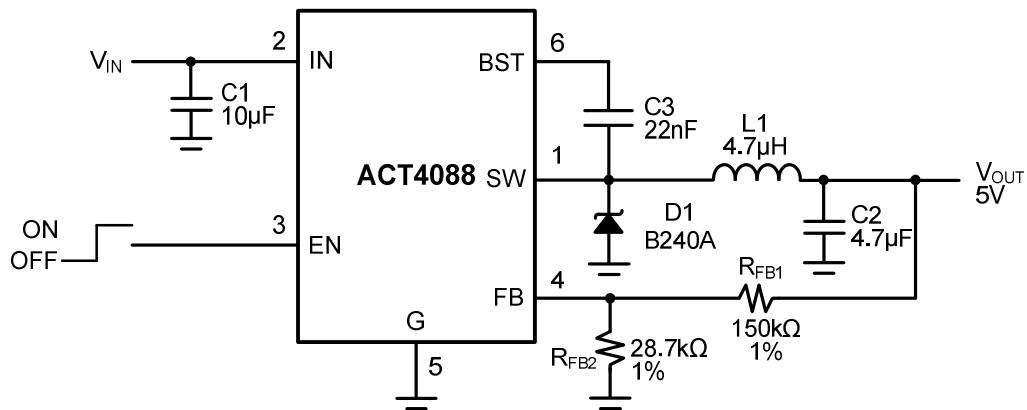
**Figure 2:**  
**ACT4088 Typical 5V/1.5A Output Application**



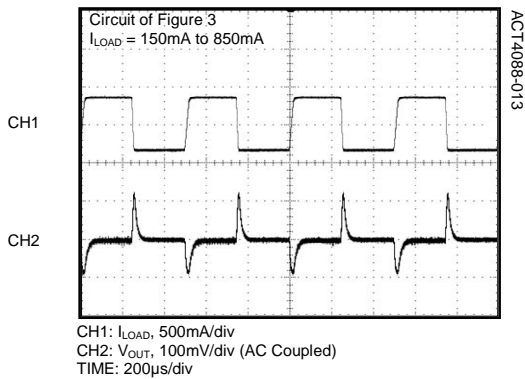


**Figure 3:**  
**ACT4088 Optimized for Minimal External Components**

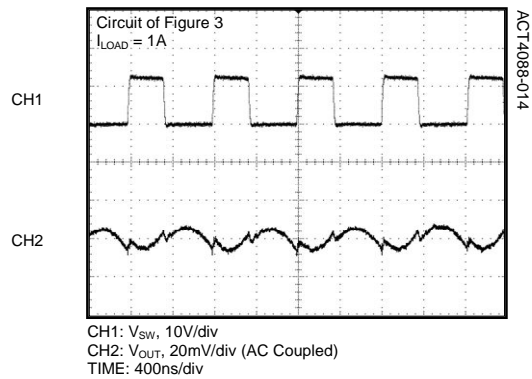
The ACT4088 provides excellent AC and DC results across a wide range of external component combinations. The circuit of Figure 3 can be used to generate a 5V output from a 12V input utilizing a smaller (i.e. lower-cost) output capacitor while maintaining good performance.



**Figure 4:**  
**Circuit of Figure 3 ( $I_{LOAD} = 150\text{mA}$  to  $850\text{mA}$ )**



**Figure 5:**  
**Circuit of Figure 3 ( $I_{LOAD} = 1\text{A}$ )**



## Hiccup Mode

If the ACT4088 transitions from normal operation to a severe overload condition (the voltage at FB falls below 0.3V), the controller automatically enters "Hiccup Mode" to provide maximum protection to the system. In hiccup mode, the IC stops switching, clears the soft-start circuitry, then attempts to re-start. If the overload condition has been removed, the IC will start up normally and continue regulating. In the case of a sustained overload, however, the IC will attempt to regulate for a period of time equal to 3x the soft-start period (1.5ms). If the overload condition persists until the end of this period, the IC will begin another hiccup cycle. This hiccup-mode control scheme minimizes power dissipation during severe overload conditions, and ensures that the ACT4088 responds quickly to instantaneous severe overload conditions while providing immunity to false hiccups that may occur with a heavily loaded output.

## Thermal Shutdown

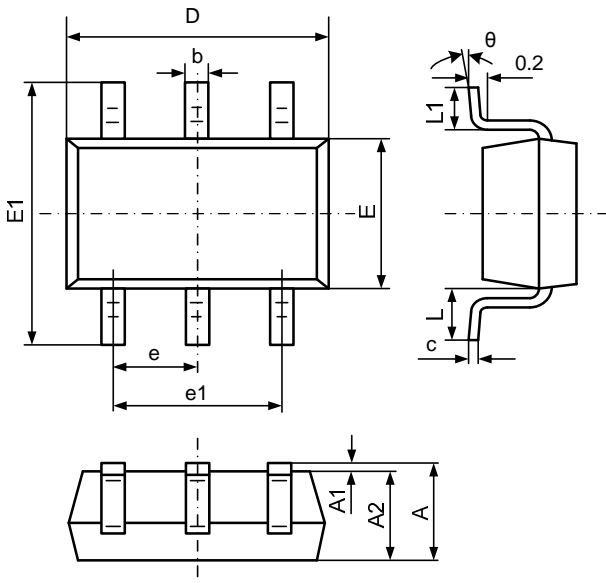
The ACT4088 automatically turns off when the IC junction temperature exceeds 160°C, and re-enables when the IC junction temperature drops by 10°C (typ).

## PC Board Layout

The high current paths at G, IN and SW should be placed very close to the device with short, direct and wide traces. The input capacitor needs to be as close as possible to the IN and G pins. The external feedback resistors should be placed next to the FB pin. Keep the switch node traces short and away from the feedback network and use shielded inductors.

## PACKAGE OUTLINE

### SOT23-6 PACKAGE OUTLINE AND DIMENSIONS



SYMBOL	DIMENSION IN MILLIMETERS		DIMENSION IN INCHES	
	MIN	MAX	MIN	MAX
A	1.050	1.250	0.041	0.049
A1	0.000	0.100	0.000	0.004
A2	1.050	1.150	0.041	0.045
b	0.300	0.500	0.012	0.020
c	0.100	0.200	0.004	0.008
D	2.820	3.020	0.111	0.119
E	1.500	1.700	0.059	0.067
E1	2.650	2.950	0.104	0.116
e	0.950 TYP		0.037 TYP	
e1	1.800	2.000	0.071	0.079
L	0.700 REF		0.028 REF	
L1	0.300	0.600	0.012	0.024
θ	0°	8°	0°	8°

Active-Semi, Inc. reserves the right to modify the circuitry or specifications without notice. Users should evaluate each product to make sure that it is suitable for their applications. Active-Semi products are not intended or authorized for use as critical components in life-support devices or systems. Active-Semi, Inc. does not assume any liability arising out of the use of any product or circuit described in this datasheet, nor does it convey any patent license.

Active-Semi and its logo are trademarks of Active-Semi, Inc. For more information on this and other products, contact [sales@active-semi.com](mailto:sales@active-semi.com) or visit <http://www.active-semi.com>. For other inquiries, please send to:

1270 Oakmead Parkway, Suite 310, Sunnyvale, California 94085-4044, USA