



AIC1648

Built-in OVP White LED Step-Up Converter

FEATURES

- Built-In Open Circuit Protection
- Over Voltage Protection
- Efficiency Up to 84% at $V_{IN}=4.2V$, 3LEDs, $I_{LED}=20mA$
- 1.2MHz Fixed Switching Frequency
- Drives Up to 5LEDs in series
- Low Supply Current: 70 μ A
- Matches LED Current
- Requires Tiny Inductor and Capacitors
- Tiny SOT-23-6 Package

APPLICATIONS

- Cellular Phones
- PDAs
- DSCs
- Handheld Devices
- White LED Display Backlighting

DESCRIPTION

AIC1648 is a fixed frequency step-up DC/DC converter designed to drive white LEDs with a constant current to provide backlight in hand-held devices. Series connection of LEDs provides identical LED currents resulting in uniform brightness. This configuration eliminates the need of ballast resistors. The built-in open load protection prevents the damage resulting from an open circuit condition. Low 95mV feedback voltage minimizes power loss in the current setting resistor for better efficiency.

AIC1648 is a step-up PWM converter, which includes an internal N-channel MOSFET switch for high efficiency. The high switching frequency, 1.2MHz, allows the use of tiny external components.

AIC1648 is available in a space-saving, 6-lead SOT-23-6 package.

TYPICAL APPLICATION CIRCUIT

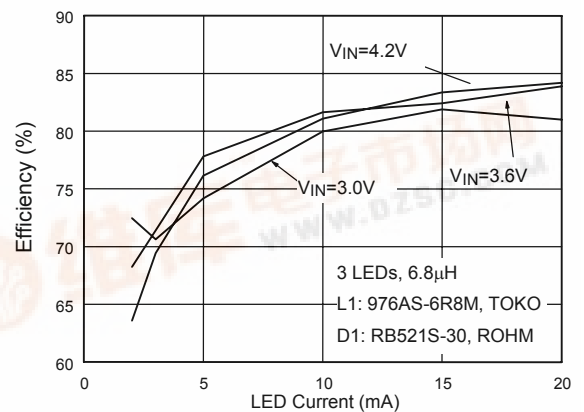
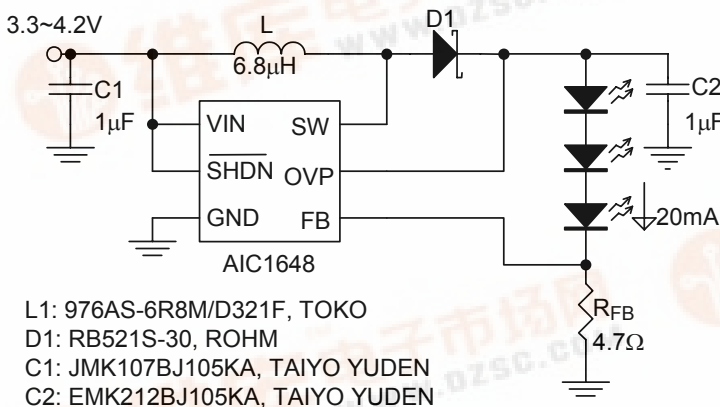
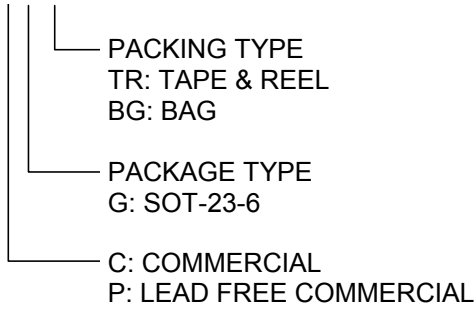
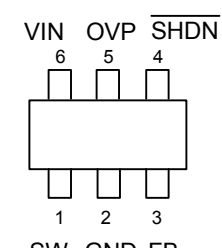

Fig. 1 Li-Ion Powered Driver for Three White LEDs

ORDERING INFORMATION

AIC1648XXXX



ORDER NUMBER	PIN CONFIGURATION
AIC1648CG&PG (SOT-23-6)	FRONT VIEW 

Example: AIC1648CGTR
 → in SOT-23-6 Package & Tape & Reel Packing Type

MARKING

Part No.	CG	PG
AIC1648	1648	1648P

ABSOLUTE MAXIMUM RATINGS

Input Voltage (VIN)	6V
SW Voltage	33V
FB Voltage	6V
SHDN Voltage	6V
OVP Voltage	34V
Operating Temperature Range	-40°C to 85°C
Maximum Junction Temperature	125°C
Storage Temperature Range	-65°C to 150°C
Lead Temperature (Soldering, 10 sec)	260°C

Absolute Maximum Ratings are those values beyond which the life of a device may be impaired.

TEST CIRCUIT

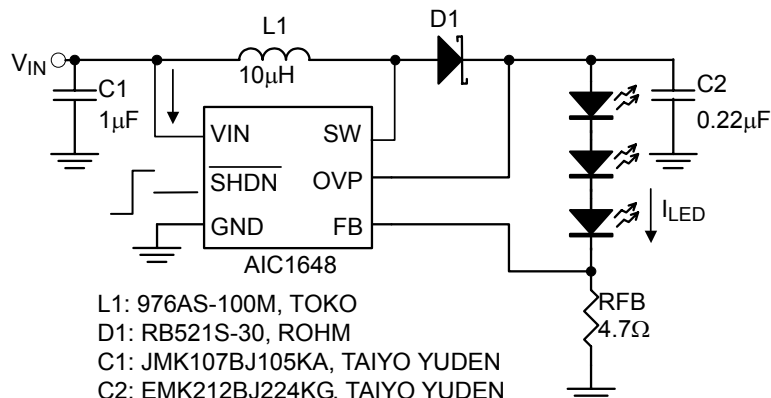

ELECTRICAL CHARACTERISTICS

 ($V_{\overline{\text{SHDN}}}=3\text{V}$, $V_{\text{IN}}=3\text{V}$, $T_{\text{A}}=25^{\circ}\text{C}$, unless otherwise specified.) (Note 1)

PARAMETER	SYMBOL	TEST CONDITIONS	MIN	TYP	MAX	UNIT
Minimum Operating Voltage	V_{IN}		2.5			V
Maximum Operating Voltage	V_{IN}				5.5	V
Supply Current	I_{IN}	Switching		1	5	mA
		Non switching		70	100	μA
		$V_{\overline{\text{SHDN}}}=0\text{V}$		0.1	1.0	
ERROR AMPLIFIER						
Feedback Voltage	V_{FB}		85	95	105	mV
FB Input Bias Current	I_{FB}	$V_{\text{FB}}=95\text{mV}$		1		nA
OSCILLATOR						
Switching Frequency	f_{OSC}		0.8	1.2	1.6	MHz
Maximum Duty Cycle	DC		85	90		%
POWER SWITCH						
SW ON Resistance	$R_{\text{DS(ON)}}$			1.4	5	Ω
Switch Leakage Current	$I_{\text{SW(OFF)}}$	$V_{\text{SW}}=33\text{V}$		0.1	1	μA
CONTROL INPUT						
$\overline{\text{SHDN}}$ Voltage High	V_{IH}	ON	1.5			V
$\overline{\text{SHDN}}$ Voltage Low	V_{IL}	OFF			0.3	V
OVER VOLTAGE PROTECTION						
OVP Input Resistance	R_{OVP}		0.6	1.2	1.8	$\text{M}\Omega$
OVP Threshold	V_{OVP}	1V Hysteresis typical	22	27	32	V

Note 1: Specifications are production tested at $T_{\text{A}}=25^{\circ}\text{C}$. Specifications over the -40°C to 85°C operating temperature range are assured by design, characterization and correlation with Statistical Quality Controls (SQC).

TYPICAL PERFORMANCE CHARACTERISTICS

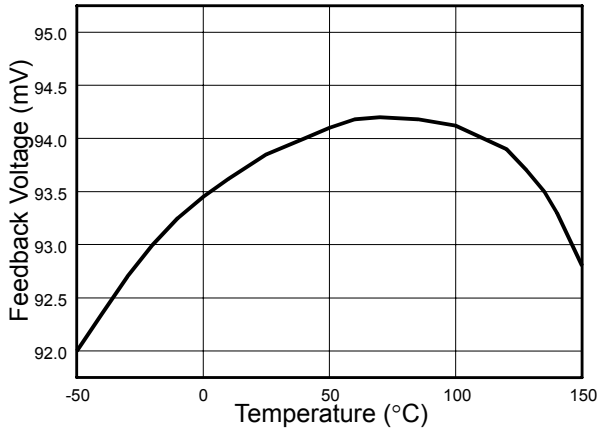

Fig. 2 Feedback Voltage vs. Temperature

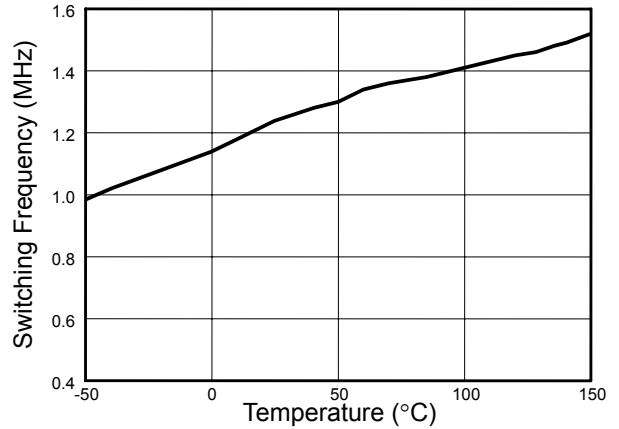

Fig. 3 Switching Frequency vs. Temperature

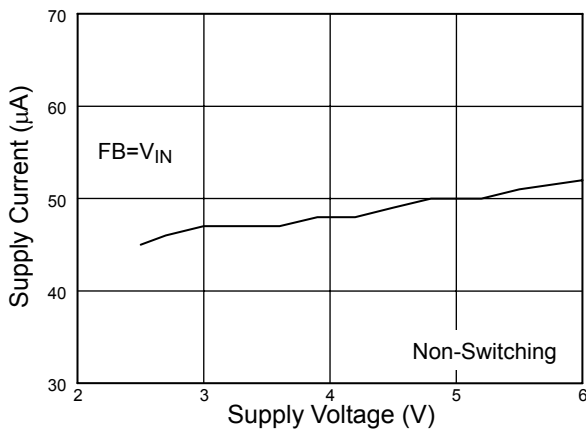

Fig. 4 Supply Current vs. Supply Voltage

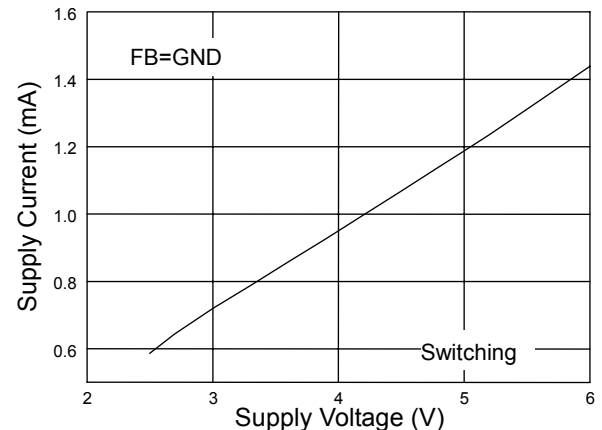

Fig. 5 Supply Current vs. Supply Voltage

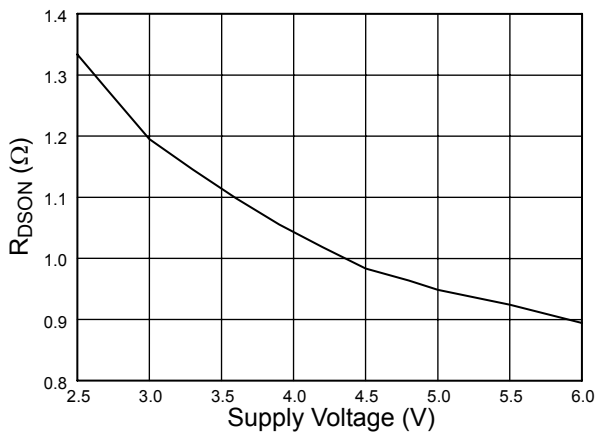

Fig. 6 R_{DS-ON} vs. Supply Voltage

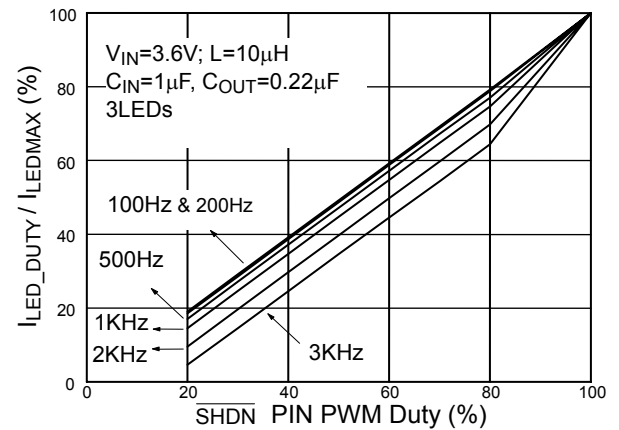

Fig. 7 Dimming Control by Shutdown PIN

■ TYPICAL PERFORMANCE CHARACTERISTICS (Continued)

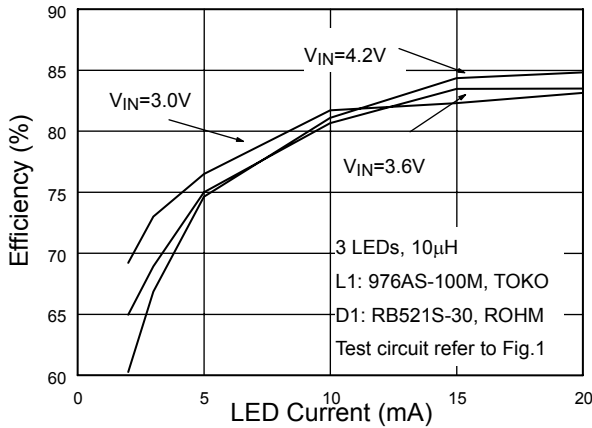

Fig. 8 3 LEDs Efficiency vs. LED Current

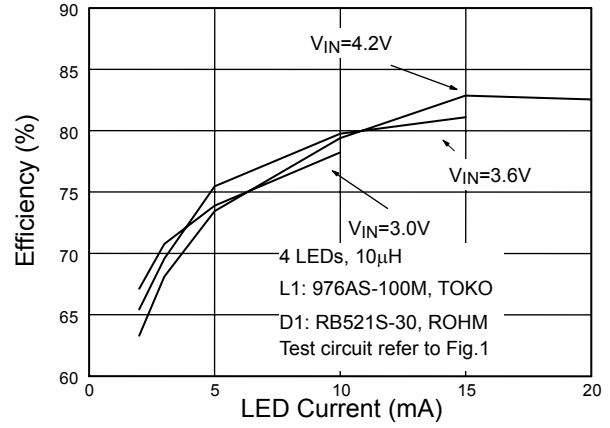

Fig. 9 4 LEDs Efficiency vs. LED Current

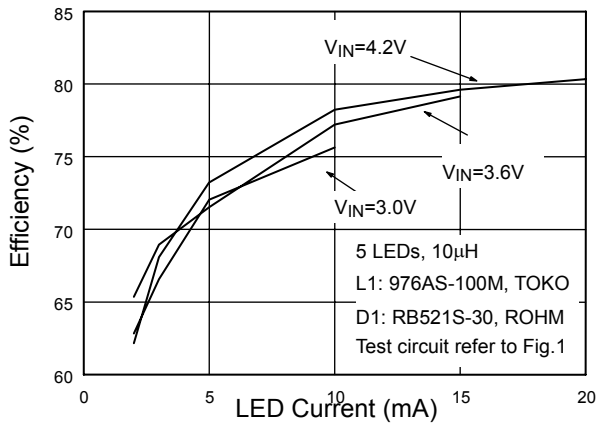

Fig. 10 5 LEDs Efficiency vs. LED Current

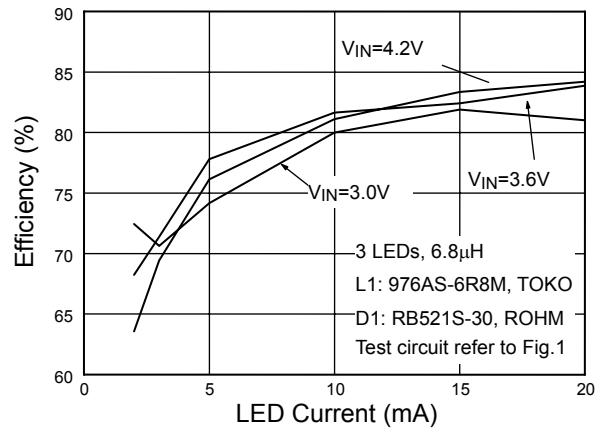

Fig. 11 3 LEDs Efficiency vs. LED Current

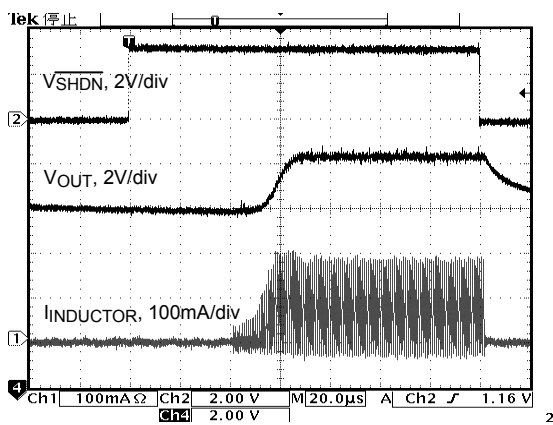

Fig. 12 Start-Up from Shutdown
VIN=3.6V; 3 LEDs; L1=10µF; COUT=0.22µF; ILED=20mA

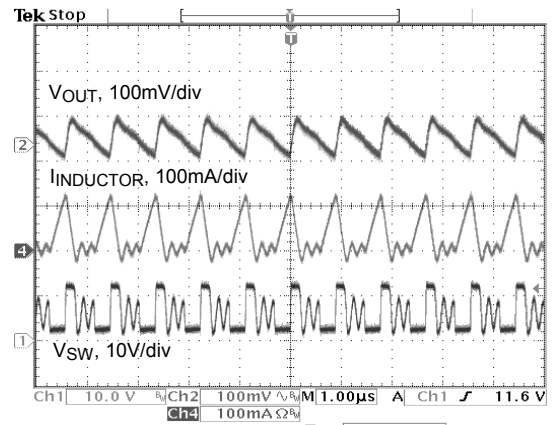

Fig. 13 Operation Wave Form
VIN=3.6V; 3 LEDs; L1=10µF; COUT=0.22µF; ILED=10mA

TYPICAL PERFORMANCE CHARACTERISTICS (Continued)

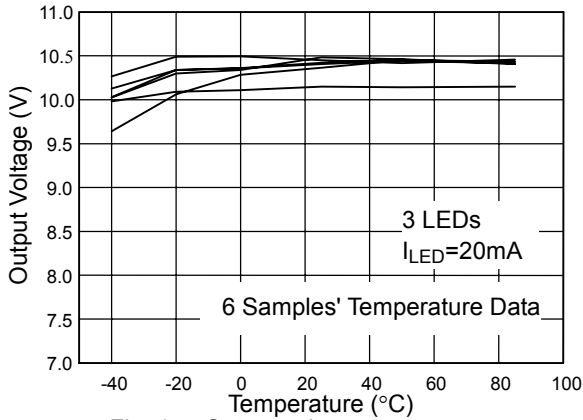

Fig. 14 Output voltage vs. temperature

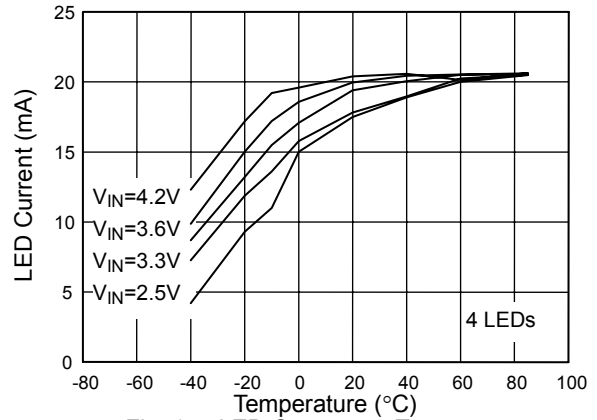
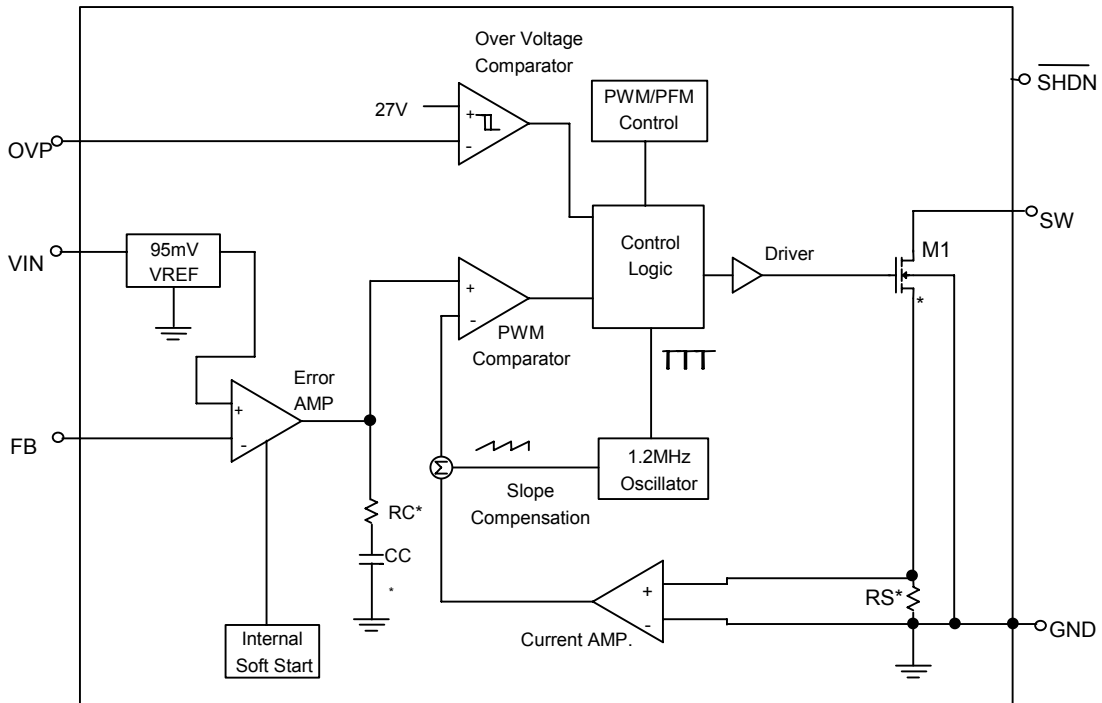

Fig. 15 LED Current vs. Temperature

BLOCK DIAGRAM



■ PIN DESCRIPTIONS

PIN 1: SW - Switch pin. Connect inductor/diode here. Minimize trace area at this pin to reduce EMI.

PIN 2: GND - Ground pin. Tie directly to local ground plane.

PIN 3: FB - Feedback pin. Reference voltage is 95mV. Connect cathode of lowest LED and resistor here. Calculate resistor value to obtain LED current according to the formula:

$$R_{FB} = 95\text{mV}/I_{LED}$$

PIN 4: $\overline{\text{SHDN}}$ - Shutdown pin. Tie to higher than 1.5V to enable device, 0.3V or less to disable device.

PIN 5: OVP - Overvoltage protection. When VOUT is greater than 27V, the internal MOSFET turns off.

PIN 6: VIN - Power input pin. Bypass VIN to GND with a capacitor sitting as close to VIN as possible.

■ APPLICATION INFORMATION

Inductor Selection

A 10 μ H inductor is recommended for most AIC1648 applications. Although small size and high efficiency are major concerns, the inductor should have low core losses at 1.2MHz and low DCR (copper wire resistance).

Capacitor Selection

The small size of ceramic capacitors makes them ideal for AIC1648 applications. X5R and X7R types are recommended because they retain their capacitance over wider ranges of voltage and temperature than other types, such as Y5V or Z5U. 1 μ F input capacitor with 1 μ F output capacitor are sufficient for most AIC1648 applications.

Diode Selection

Schottky diodes, with their low forward voltage drop and fast reverse recovery, are the ideal choices for AIC1648 applications. The forward voltage drop of a Schottky diode represents the conduction losses in the diode, while the diode capacitance (CT or CD) represents the switching losses. For diode selection, both forward voltage drop and diode capacitance need to be considered. Schottky diodes with higher current ratings usually have lower forward voltage drop

and larger diode capacitance, which can cause significant switching losses at the 1.2MHz switching frequency of AIC1648. A Schottky diode rated at 100mA to 200mA is sufficient for most AIC1648 applications.

LED Current Control

LED current is controlled by feedback resistor (R_{FB} in Figure 1). The feedback reference voltage is 95mV. The LED current is $95\text{mV}/R_{FB}$. In order to have accurate LED current, precision resistors are preferred (1% recommended). The formula for R_{FB} selection is shown below.

$$R_{FB} = 95\text{mV}/I_{LED}$$

Open-Circuit Protection

In the cases of output open circuit, when the LEDs are disconnected from the circuit or the LEDs fail, the feedback voltage will be zero. AIC1648 will then switch to a high duty cycle resulting in a high output voltage, which may cause SW pin voltage to exceed its maximum 33V rating. Connect built-in OVP (Over Voltage Protection) pin to output terminal to prevent the damage resulting from an open circuit condition.

Dimming Control

There are three different ways of dimming control circuits as follows:

1. Using a PWM signal

PWM brightness control provides the widest dimming range by pulsing the LEDs on and off at full and zero current, respectively. The change of average LED current depends on the duty cycle of the PWM signal. Typically, a 0.1kHz to 1kHz PWM signal is used. Two applications of PWM dimming with AIC1648 are shown in Figure 16 and Figure 17. One, as Figure 16, uses PWM signal to drive $\overline{\text{SHDN}}$ pin directly for dimming control. The other, as Figure 17, employs PWM signal going through a resistor to drive FB pin. If the $\overline{\text{SHDN}}$ pin is used, the increase of duty cycle results in LED brightness enhancement. If the FB pin is used, on the contrary, the increase of duty

cycle will decrease its brightness. In this application, LEDs are dimmed by FB pin and turned off completely by $\overline{\text{SHDN}}$.

2. Using a DC Voltage

For some applications, the preferred method of a dimming control uses a variable DC voltage to adjust LED current. The dimming control using a DC voltage is shown in Figure 18. With a VDC ranging from 0V to 5V, the selection of resistors in Figure 18 results in dimming control of LED current from 20mA to 0mA, respectively.

3. Using a Filtered PWM Signal

Filtered PWM signal can be considered as an adjustable DC voltage. It can be used to replace the variable DC voltage source in dimming control. The circuit is shown in Figure 19.

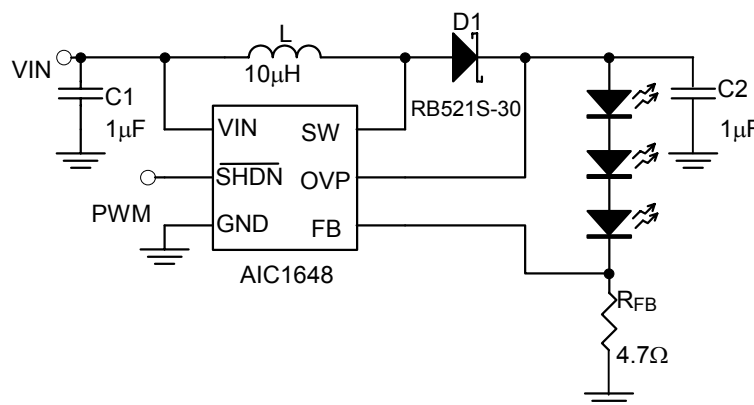

Fig. 16 Dimming Control with a PWM Signal

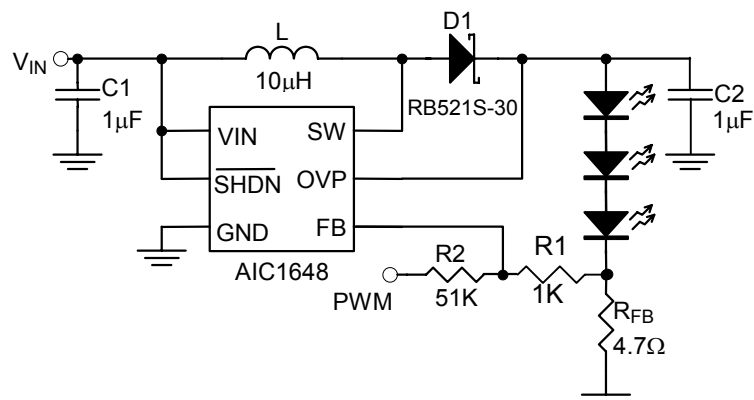

Fig. 17 Dimming Control Using a PWM Signal

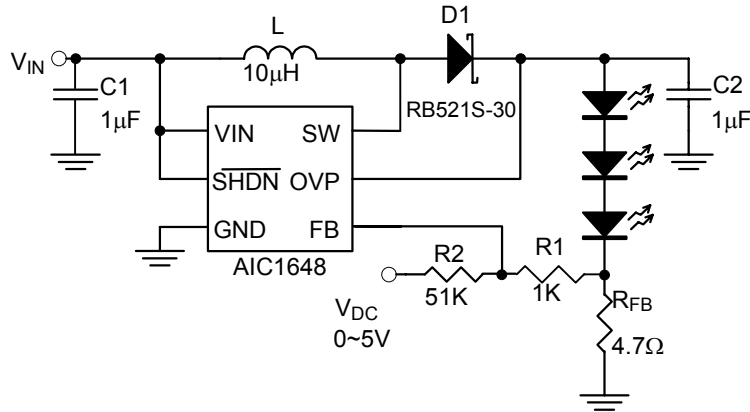

Fig. 18 Dimming Control Using a DC Voltage

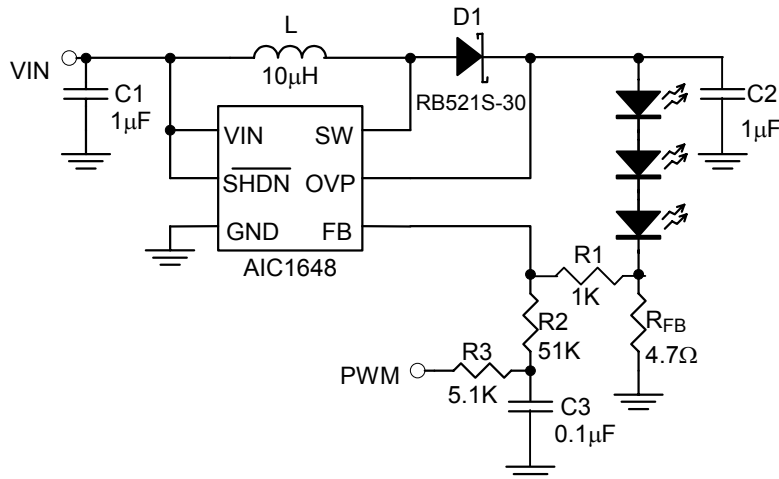

Fig. 19 Dimming Control Using a Filter PWM Signal

■ APPLICATION EXAMPLE

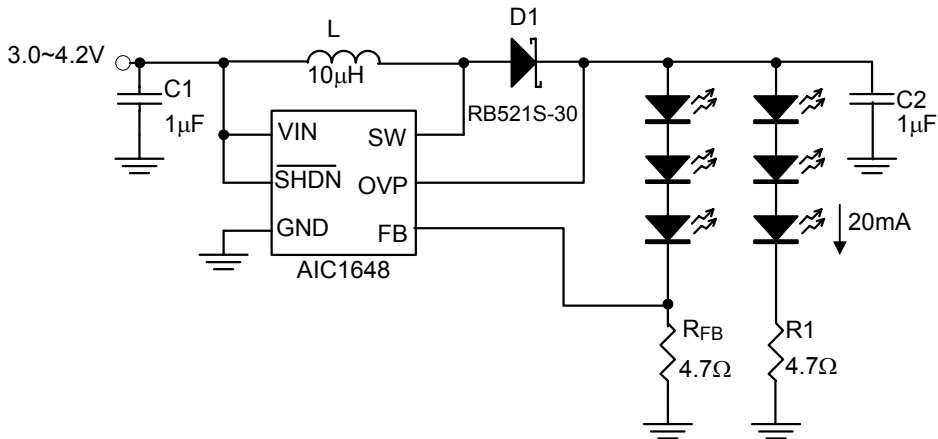
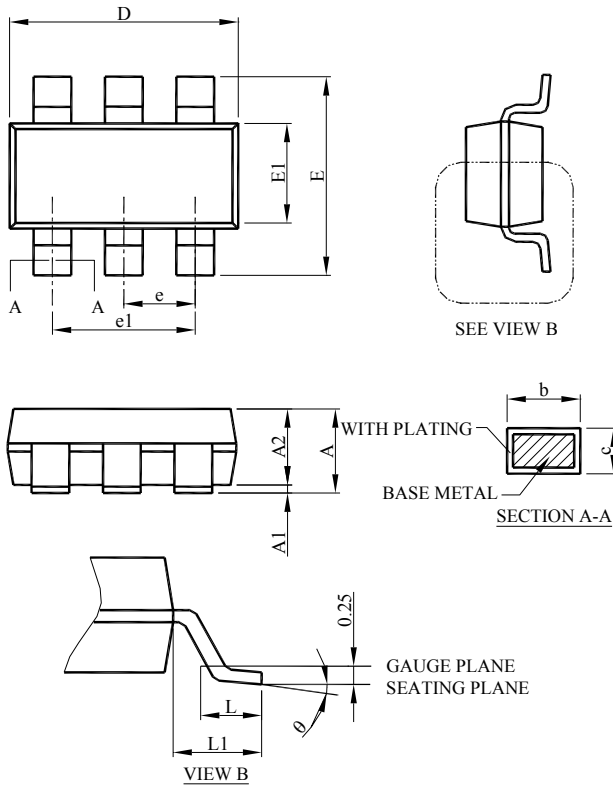

Fig. 20 Six White LEDs Application in Li-Ion Battery

PHYSICAL DIMENSIONS (unit: mm)
SOT-23-6

SYMBOL	SOT-26	
	MILLIMETERS	
	MIN.	MAX.
A	0.95	1.45
A1	0.05	0.15
A2	0.90	1.30
b	0.30	0.50
c	0.08	0.22
D	2.80	3.00
E	2.60	3.00
E1	1.50	1.70
e	0.95 BSC	
e1	1.90 BSC	
L	0.30	0.60
L1	0.60 REF	
θ	0°	8°

Note:

Information provided by AIC is believed to be accurate and reliable. However, we cannot assume responsibility for use of any circuitry other than circuitry entirely embodied in an AIC product; nor for any infringement of patents or other rights of third parties that may result from its use. We reserve the right to change the circuitry and specifications without notice.

Life Support Policy: AIC does not authorize any AIC product for use in life support devices and/or systems. Life support devices or systems are devices or systems which, (i) are intended for surgical implant into the body or (ii) support or sustain life, and whose failure to perform, when properly used in accordance with instructions for use provided in the labeling, can be reasonably expected to result in a significant injury to the user.