

$V_{RRM} = 5500 \text{ V}$

$I_{F(AV)M} = 585 \text{ A}$

$I_{FSM} = 18 \times 10^3 \text{ A}$

$V_{(T0)} = 4.5 \text{ V}$

$r_T = 1.3 \text{ mW}$

$V_{DClink} = 3300 \text{ V}$

Fast Recovery Diode

5SDF 08H6005

PRELIMINARY

Doc. No. 5SYA1116-01 Oct. 06

- Patented free-floating technology
- Industry standard housing
- Cosmic radiation withstand rating
- Low on-state and switching losses
- Optimized for snubberless operation

Blocking

Maximum rated values ¹⁾

Parameter	Symbol	Conditions	Value	Unit
Repetitive peak reverse voltage	V_{RRM}	$f = 50 \text{ Hz}, t_p = 10\text{ms}, T_{vj} = 115^\circ\text{C}$	5500	V
Permanent DC voltage for 100 FIT failure rate	$V_{DC-link}$	Ambient cosmic radiation at sea level in open air. (100% Duty)	3300	V
Permanent DC voltage for 100 FIT failure rate	$V_{DC-link}$	Ambient cosmic radiation at sea level in open air. (5% Duty)	3900	V

Characteristic values

Parameter	Symbol	Conditions	min	typ	max	Unit
Repetitive peak reverse current	I_{RRM}	$V_R = V_{RRM}, T_{vj} = 115^\circ\text{C}$			30	mA

Mechanical data

Maximum rated values ¹⁾

Parameter	Symbol	Conditions	min	typ	max	Unit
Mounting force	F_m		42	40	46	kN
Acceleration	a	Device unclamped			50	m/s^2
Acceleration	a	Device clamped			200	m/s^2

Characteristic values

Parameter	Symbol	Conditions	min	typ	max	Unit
Weight	m				0.83	kg
Housing thickness	H		26.2		26.6	mm
Surface creepage distance	D_s		30			mm
Air strike distance	D_a		20			mm

Note 1 Maximum rated values indicate limits beyond which damage to the device may occur

On-state

Maximum rated values ¹⁾

Parameter	Symbol	Conditions	min	typ	max	Unit
Max. average on-state current	$I_{F(AV)M}$	Half sine wave, $T_C = 70\text{ °C}$			585	A
Max. RMS on-state current	$I_{F(RMS)}$				920	A
Max. peak non-repetitive surge current	I_{FSM}	$t_p = 10\text{ ms}$, $T_{vj} = 115\text{ °C}$, $V_R = 0\text{ V}$			18×10^3	A
Limiting load integral	I^2t				1.62×10^6	A^2s
Max. peak non-repetitive surge current	I_{FSM}	$t_p = 1\text{ ms}$, $T_{vj} = 115\text{ °C}$, $V_R = 0\text{ V}$			40×10^3	A
Limiting load integral	I^2t				800×10^3	A^2s

Characteristic values

Parameter	Symbol	Conditions	min	typ	max	Unit
On-state voltage	V_F	$I_F = 1800\text{ A}$, $T_{vj} = 115\text{ °C}$			6.85	V
Threshold voltage	$V_{(T0)}$	$T_{vj} = 115\text{ °C}$			4.5	V
Slope resistance	r_T	$I_F = 400 \dots 2500\text{ A}$			1.3	$m\Omega$

Turn-on

Characteristic values

Parameter	Symbol	Conditions	min	typ	max	Unit
Peak forward recovery voltage	V_{FRM}	$di_F/dt = 1000\text{ A}/\mu\text{s}$, $T_{vj} = 115\text{ °C}$			370	V

Turn-off

Maximum rated values ¹⁾

Parameter	Symbol	Conditions	min	typ	max	Unit
Max. decay rate of on-state current	di/dt_{crit}	$I_{FM} = 1800\text{ A}$, $T_{vj} = 115\text{ °C}$ $V_{DC-link} = 3300\text{ V}$			440	$A/\mu\text{s}$

Characteristic values

Parameter	Symbol	Conditions	min	typ	max	Unit
Reverse recovery current	I_{RM}	$I_{FM} = 1800\text{ A}$, $V_{DC-Link} = 3300\text{ V}$			900	A
Turn-off energy	E_{rr}	$-di_F/dt = 440\text{ A}/\mu\text{s}$, $L_{CL} = 300\text{ nH}$ $C_{CL} = 10\text{ }\mu\text{F}$, $R_{CL} = 0.65\text{ }\Omega$, $T_{vj} = 115\text{ °C}$, $D_{CL} = 5\text{SDF 08H6005}$			6.5	J

Thermal

Maximum rated values ^{Note 1}

Parameter	Symbol	Conditions	min	typ	max	Unit
Operating junction temperature range	T_{vj}		-40		115	°C
Storage temperature range	T_{stg}		-40		125	°C

Characteristic values

Parameter	Symbol	Conditions	min	typ	max	Unit
Thermal resistance junction to case	$R_{th(j-c)}$	Double-side cooled $F_m = 42...46$ kN			12	K/kW
	$R_{th(j-c)A}$	Anode-side cooled $F_m = 42...46$ kN			24	K/kW
	$R_{th(j-c)C}$	Cathode-side cooled $F_m = 42...46$ kN			24	K/kW
Thermal resistance case to heatsink	$R_{th(c-h)}$	Double-side cooled $F_m = 42...46$ kN			3	K/kW
	$R_{th(c-h)}$	Single-side cooled $F_m = 42...46$ kN			6	K/kW

Analytical function for transient thermal impedance:

$$Z_{th(j-c)}(t) = \sum_{i=1}^n R_{th i} (1 - e^{-t/t_i})$$

i	1	2	3	4
$R_{th i}$ (K/kW)	7.713	2.766	1.044	0.480
τ_i (s)	0.5316	0.0668	0.0078	0.0020

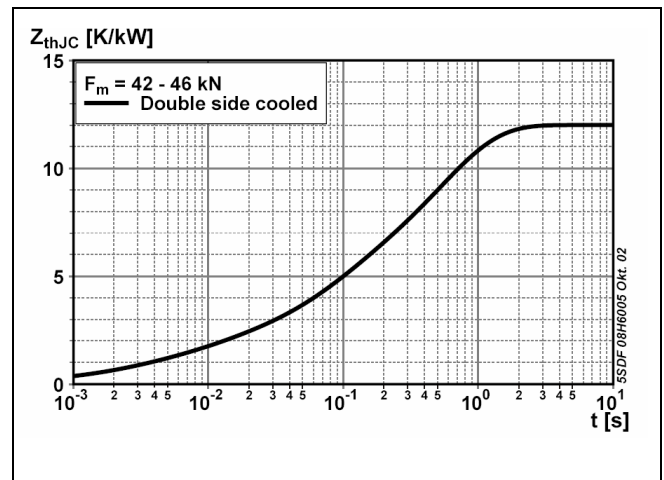

Fig. 1 Transient thermal impedance (junction to case) vs. time in analytical and graphical form (max. values)

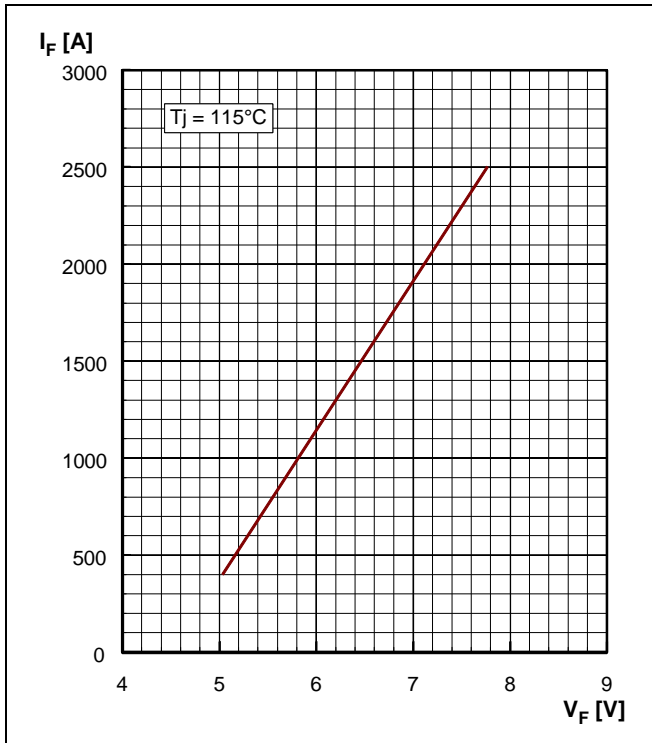

Fig. 2 Max. on-state voltage characteristics

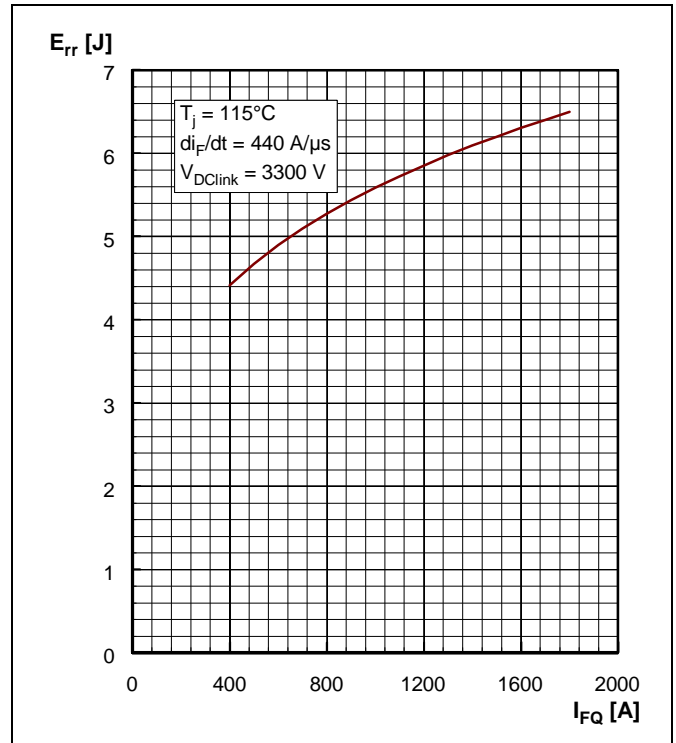

Fig. 3 Diode turn-off energy per pulse vs. turn-off current

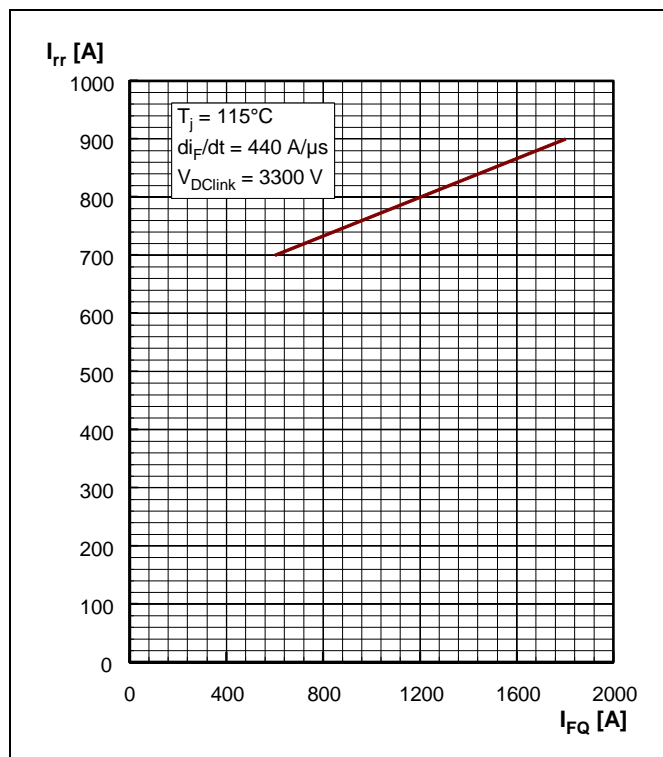

Fig. 4 Diode reverse recovery current vs. turn-off current

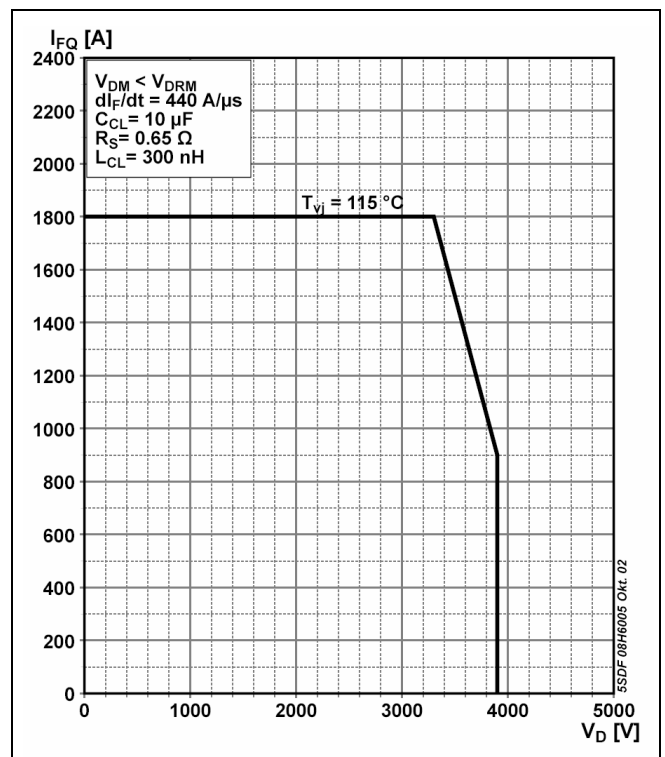

Fig. 5 Diode Safe Operating Area

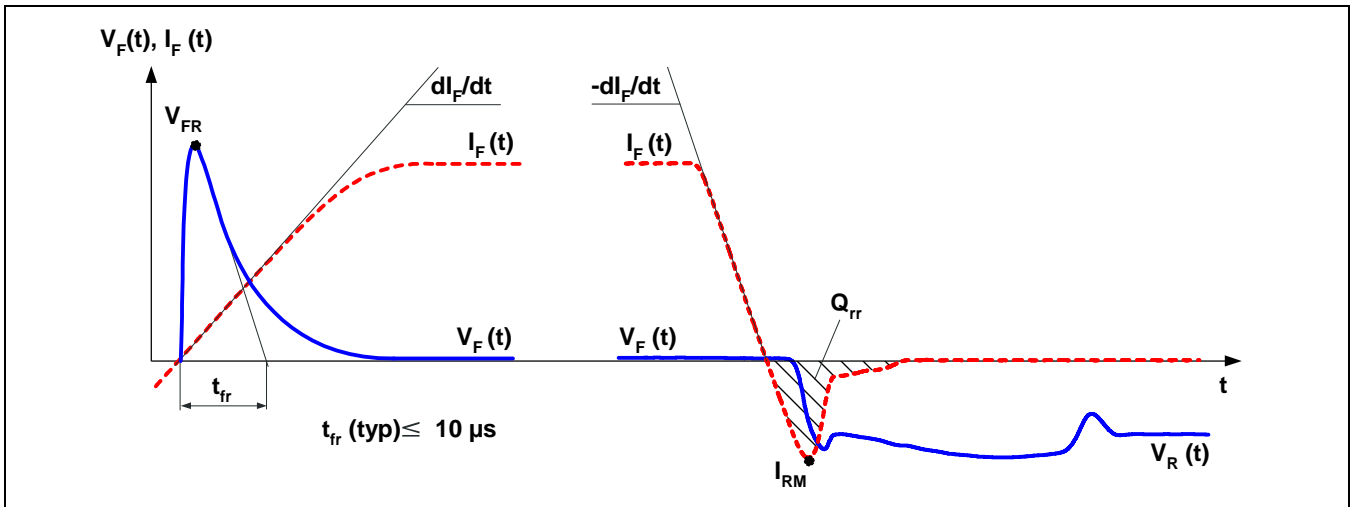

Fig. 6 General current and voltage waveforms

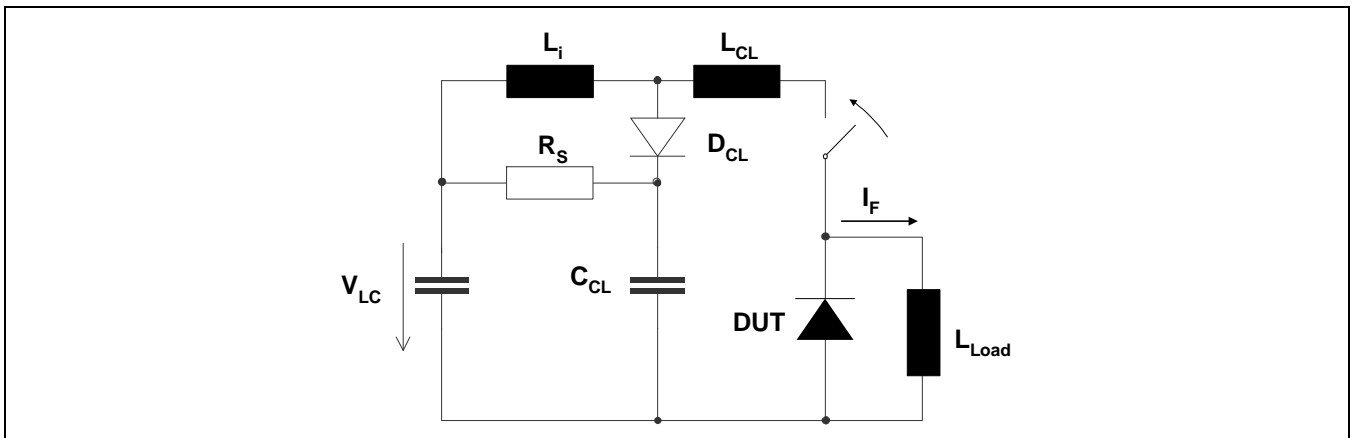

Fig. 7 Test circuit.

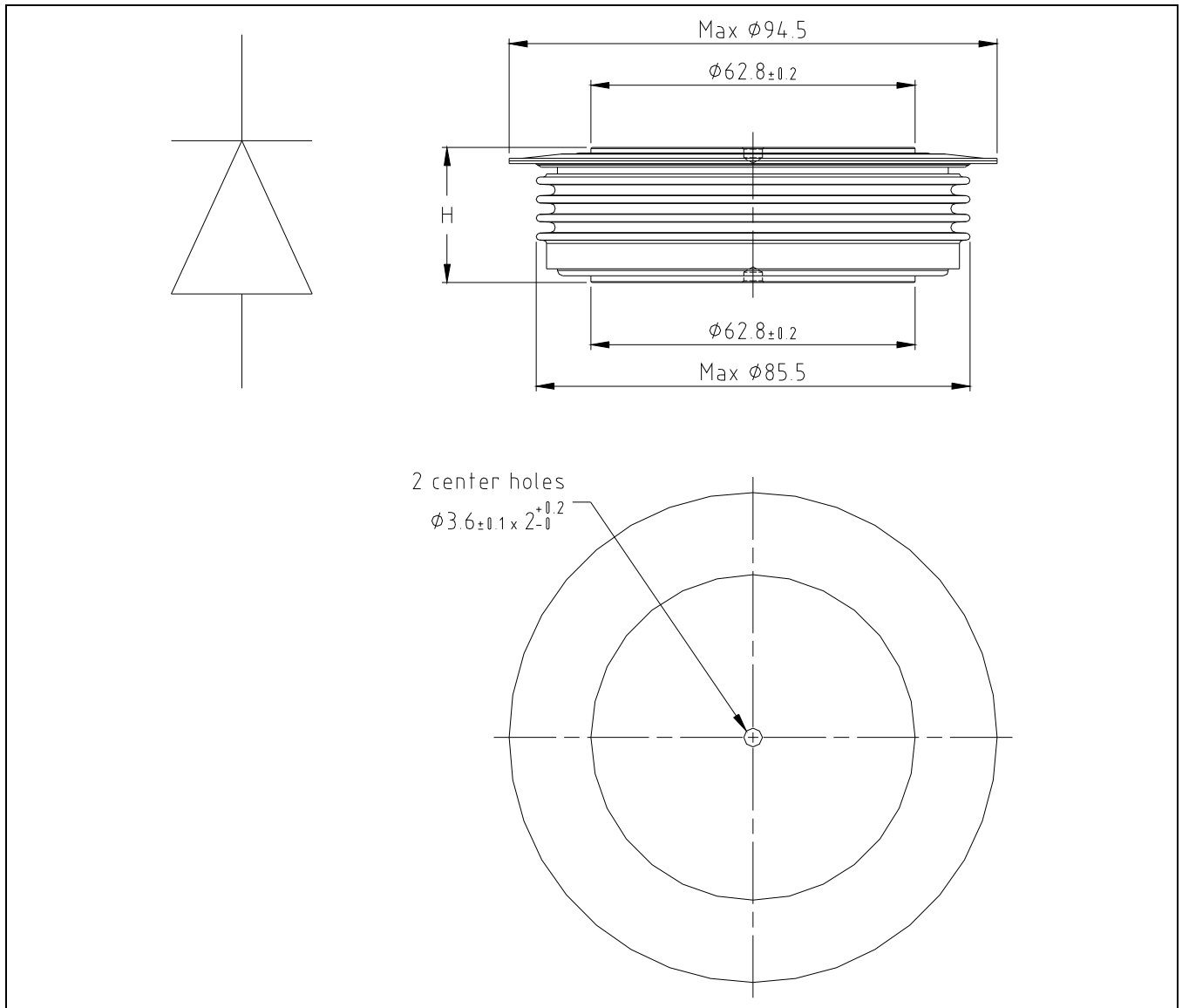

Fig. 8 Outline drawing, all dimensions are in millimeters and represent nominal values unless stated otherwise

Related documents:

Doc. Nr	Titel
5SYA 2036	Recommendations regarding mechanical clamping of Press Pack High Power Semiconductors
5SZK 9104	Specification of environmental class for pressure contact diodes, PCTs and GTO, STORAGE available on request, please contact factory
5SZK 9105	Specification of environmental class for pressure contact diodes, PCTs and GTO, TRANSPORTATION available on request, please contact factory

Please refer to <http://www.abb.com/semiconductors> for current version of documents.

ABB Switzerland Ltd, Semiconductors reserves the right to change specifications without notice.



ABB Switzerland Ltd
Semiconductors
 Fabrikstrasse 3
 CH-5600 Lenzburg, Switzerland

Doc. No. 5SYA1116-01 Oct. 06

Telephone +41 (0)58 586 1419
 Fax +41 (0)58 586 1306
 Email abbsem@ch.abb.com