

V_{SM}	$= 5200\text{ V}$	<h2 style="margin: 0;">Bi-Directional Control Thyristor</h2> <h1 style="margin: 0;">5STB 17N5200</h1>
I_{TAVM}	$= 1800\text{ A}$	
I_{TRMS}	$= 2830\text{ A}$	
I_{TSM}	$= 29000\text{ A}$	
V_{T0}	$= 1.02\text{ V}$	
r_T	$= 0.320\text{ m}\Omega$	

Doc. No. 5SYA1036-03 Sep. 01

- Two thyristors integrated into one wafer
- Patented free-floating silicon technology
- Designed for traction, energy and industrial applications
- Optimum power handling capability
- Interdigitated amplifying gate.

The electrical and thermal data are valid for one thyristor half of the device.

Blocking

Part Number	5STB 17N5200	5STB 17N5000	5STB 17N4600	Conditions
V_{SM}	5200 V	5000 V	4600 V	$f = 5\text{ Hz}, t_p = 10\text{ ms}$
V_{RM}	4400 V	4200 V	4000 V	$f = 50\text{ Hz}, t_p = 10\text{ ms}$
I_{SM}	$\leq 400\text{ mA}$			$T_j = 125^\circ\text{C}$
I_{RM}	$\leq 400\text{ mA}$			
dV/dt_{crit}	$2000\text{ V}/\mu\text{s}$			
				$@\text{ Exp. to } 0.67 \times V_{SM}$

V_{RM} is equal to V_{SM} up to $T_j = 110^\circ\text{C}$

Mechanical data

F_M	Mounting force	nom.	90 kN
		min.	81 kN
		max.	108 kN
a	Acceleration		
	Device unclamped	50 m/s^2	
	Device clamped	100 m/s^2	
m	Weight	2.9 kg	
D_s	Surface creepage distance	53 mm	
D_a	Air strike distance	22 mm	

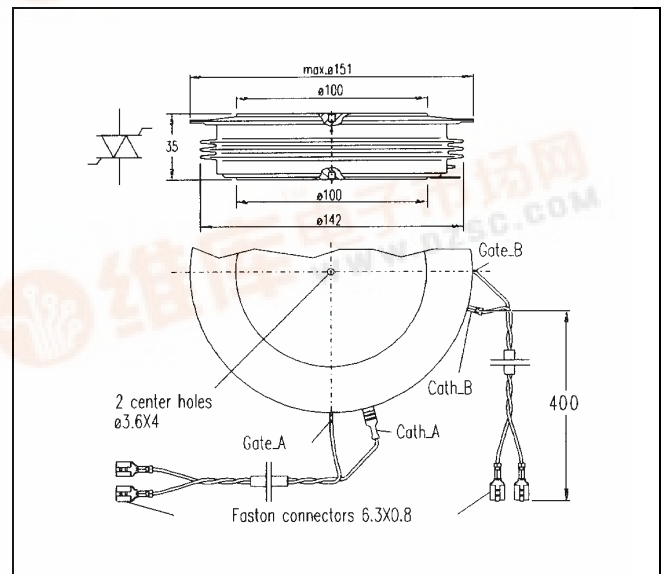

On-state

I_{TAVM}	Max. average on-state	1800 A	Half sine wave, $T_C = 70^\circ\text{C}$		
I_{TRMS}	Max. RMS on-state current	2830 A			
I_{TSM}	Max. peak non-repetitive surge current	29000 A	$t_p =$	10 ms	$T_j = 125^\circ\text{C}$ After surge: $V_D = V_R = 0\text{V}$
		31000 A	$t_p =$	8.3 ms	
I^2t	Limiting load integral	4205 kA^2s	$t_p =$	10 ms	
		3990 kA^2s	$t_p =$	8.3 ms	
V_T	On-state voltage	1.68 V	$I_T =$	2000 A	$T_j = 125^\circ\text{C}$
V_{T0}	Threshold voltage	1.02 V	$I_T =$	1000 - 3000 A	
r_T	Slope resistance	0.320 $\text{m}\Omega$			
I_H	Holding current	50-250 mA	$T_j =$	25°C	
		25-150 mA	$T_j =$	125°C	
I_L	Latching current	100-500 mA	$T_j =$	25°C	
		50-300 mA	$T_j =$	125°C	

Switching

di/dt_{crit}	Critical rate of rise of on-state current	250 $\text{A}/\mu\text{s}$	Cont. $f = 50\text{ Hz}$	$V_D \leq 0.67 \cdot V_{DRM}$, $T_j = 125^\circ\text{C}$ $I_{TRM} = 3000\text{ A}$ $I_{FG} = 2\text{ A}$, $t_r = 0.5\ \mu\text{s}$
		500 $\text{A}/\mu\text{s}$	60 sec. $f = 50\text{ Hz}$	
t_d	Delay time	$\leq 3.0\ \mu\text{s}$	$V_D = 0.4 \cdot V_{DRM}$	$I_{FG} = 2\text{ A}$, $t_r = 0.5\ \mu\text{s}$
t_q	Turn-off time	$\leq 700\ \mu\text{s}$	$V_D \leq 0.67 \cdot V_{DRM}$ $dv_D/dt = 20\text{ V}/\mu\text{s}$	$I_{TRM} = 3000\text{ A}$, $T_j = 125^\circ\text{C}$ $V_R > 200\text{ V}$, $di_T/dt = -1.5\ \text{A}/\mu\text{s}$
Q_{rr}	Recovery charge	min	4000 μAs	
		max	5200 μAs	

Triggering

V_{GT}	Gate trigger voltage	$\leq 2.6\text{ V}$	$T_j = 25^\circ\text{C}$
I_{GT}	Gate trigger current	$\leq 400\text{ mA}$	$T_j = 25^\circ\text{C}$
V_{GD}	Gate non-trigger voltage	$\geq 0.3\text{ V}$	$V_D = 0.4 \cdot V_{RM}$ $T_j = 125^\circ\text{C}$
I_{GD}	Gate non-trigger current	$\geq 10\text{ mA}$	$V_D = 0.4 \cdot V_{RM}$ $T_j = 125^\circ\text{C}$
V_{FGM}	Peak forward gate voltage	12 V	
I_{FGM}	Peak forward gate current	10 A	
V_{RGM}	Peak reverse gate voltage	10 V	
P_G	Maximum gate power loss	3 W	

Thermal

T_j	Operating junction temperature range	-40...125 °C	
T_{stg}	Storage temperature range	-40...150 °C	
R_{thJC}	Thermal resistance junction to case	22.8 K/kW	Anode side cooled
		22.8 K/kW	Cathode side cooled
		11.4 K/kW	Double side cooled
R_{thCH}	Thermal resistance case to heat sink	4 K/kW	Single side cooled
		2 K/kW	Double side cooled

Analytical function for transient thermal impedance:

$$Z_{thJC}(t) = \sum_{i=1}^n R_i(1 - e^{-t/\tau_i})$$

i	1	2	3	4
R_i (K/kW)	6.77	2.51	1.34	0.78
τ_i (s)	0.8651	0.1558	0.0212	0.0075

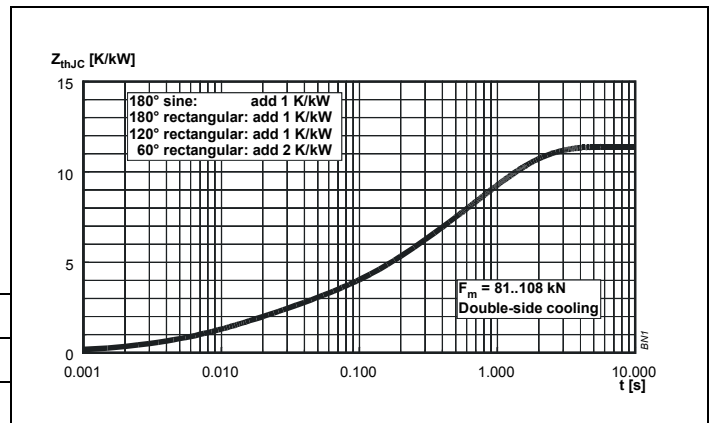

Fig. 1 Transient thermal impedance junction to case.

On-state characteristic model:

$$VT = A + B \cdot iT + C \cdot \ln(iT + 1) + D \cdot \sqrt{IT}$$

Valid for $i_T = 500 - 4000$ A

A	B	C	D
1.309	0.00008	-0.125	0.026

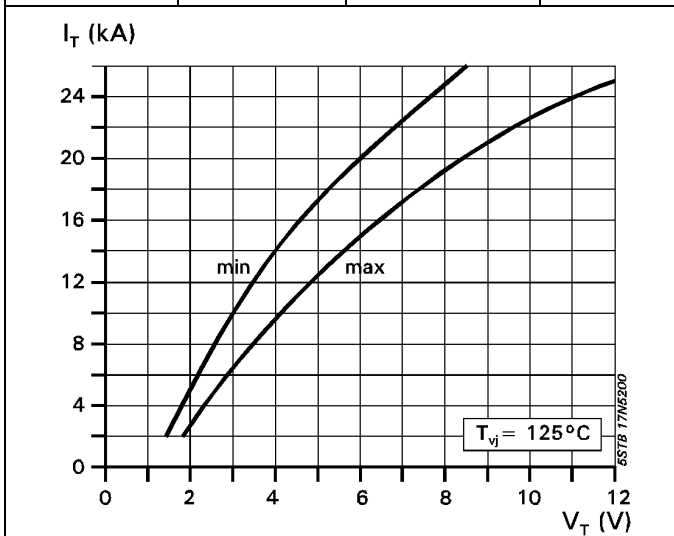

Fig. 2 On-state characteristics.

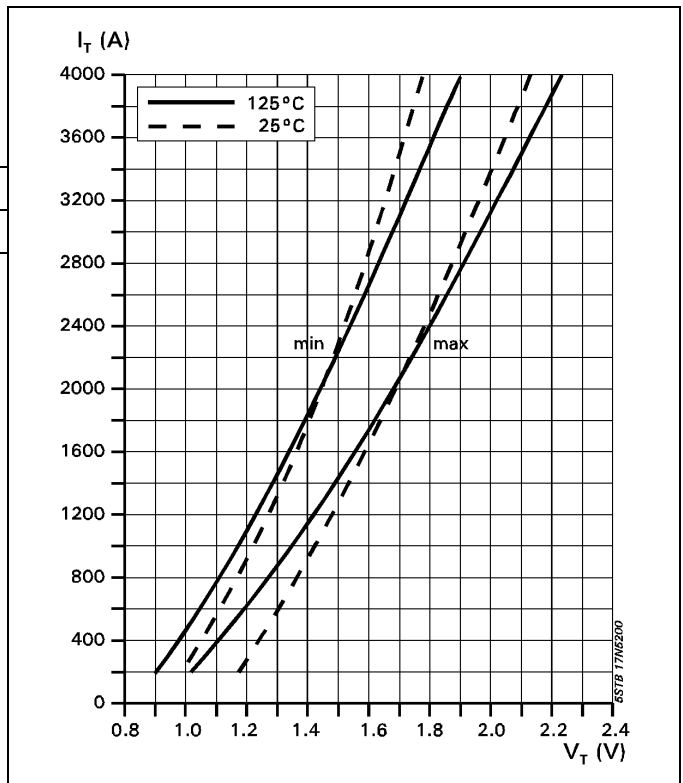

Fig. 3 On-state characteristics.

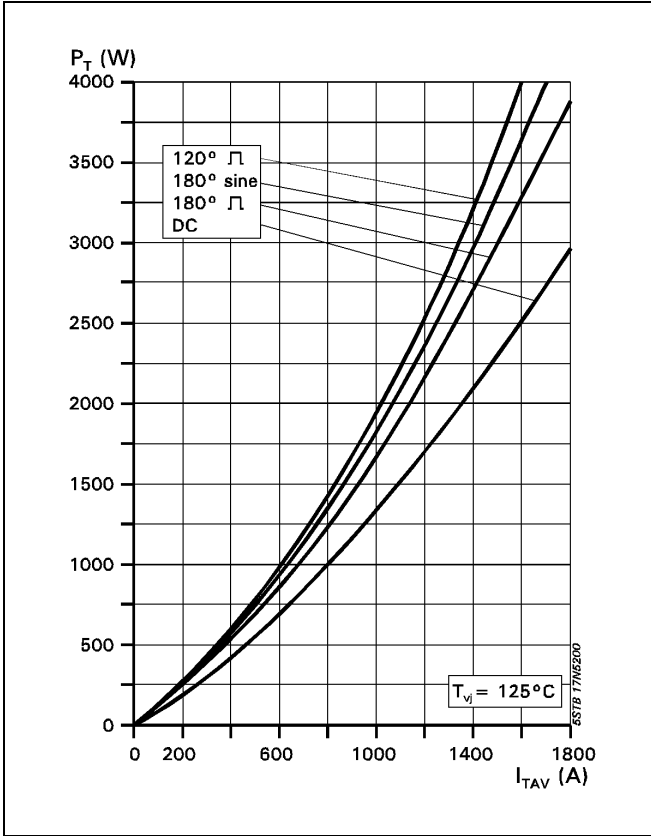

Fig. 4 On-state power dissipation vs. mean on-state current. Turn - on losses excluded.

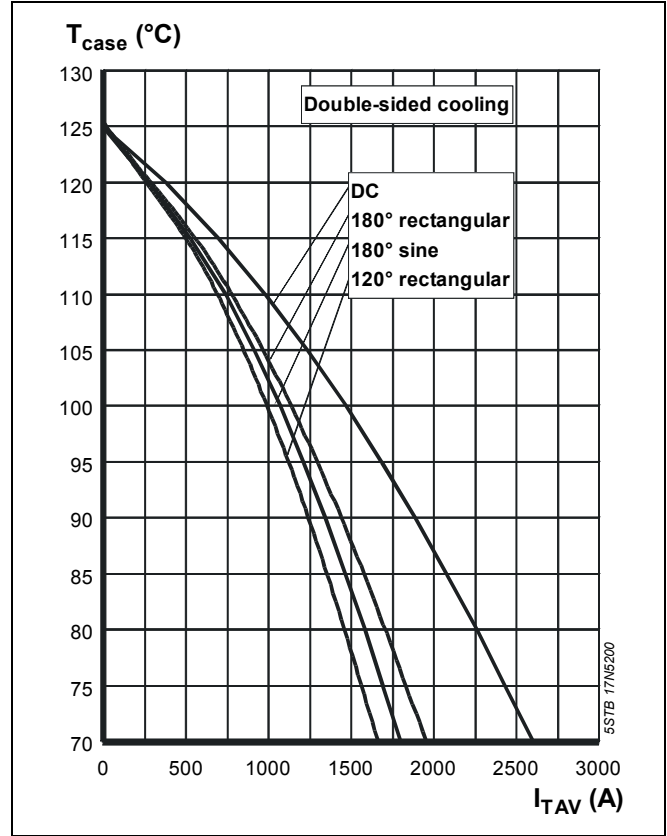

Fig. 5 Max. permissible case temperature vs. mean on-state current.

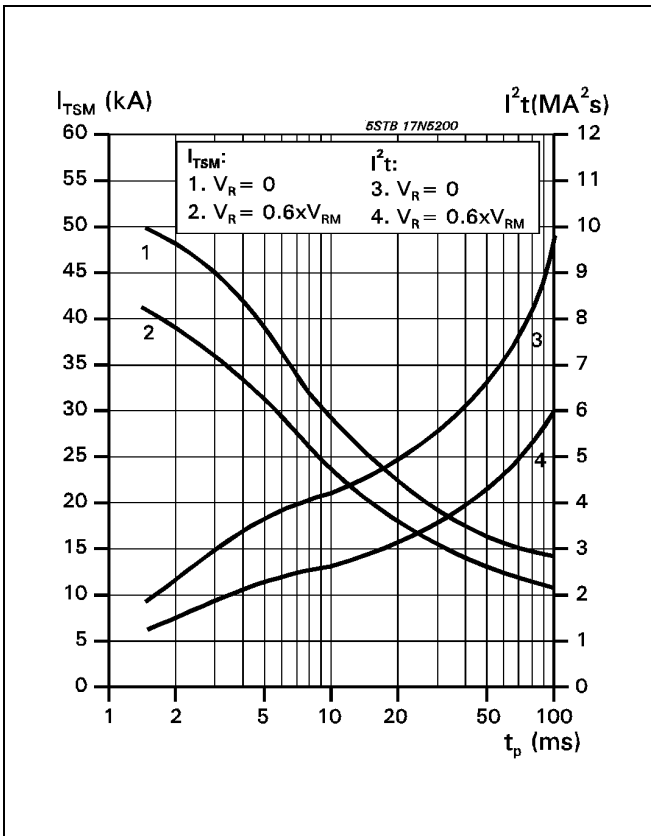

Fig. 6 Surge on-state current vs. pulse length. Half-sine wave.

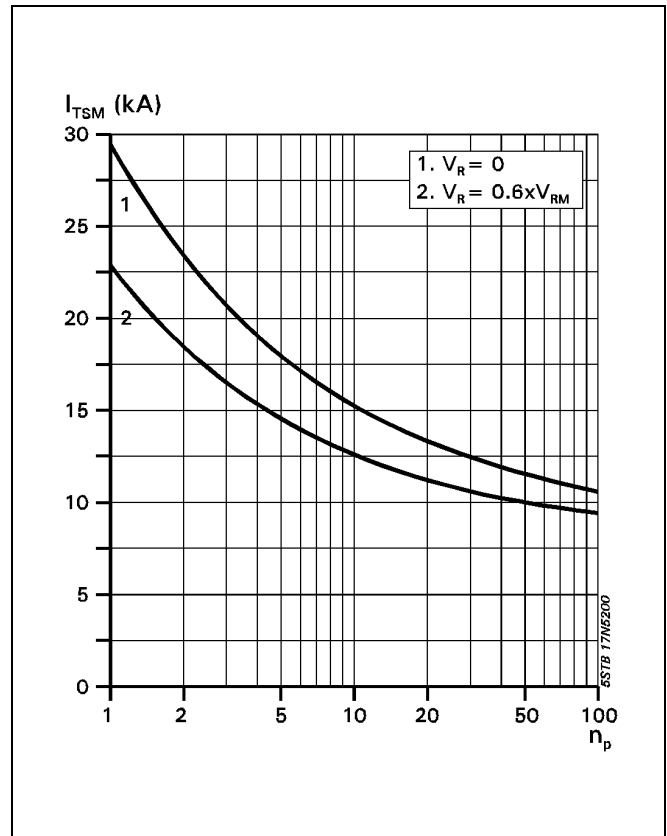

Fig. 7 Surge on-state current vs. number of pulses. Half-sine wave, 10 ms, 50Hz.

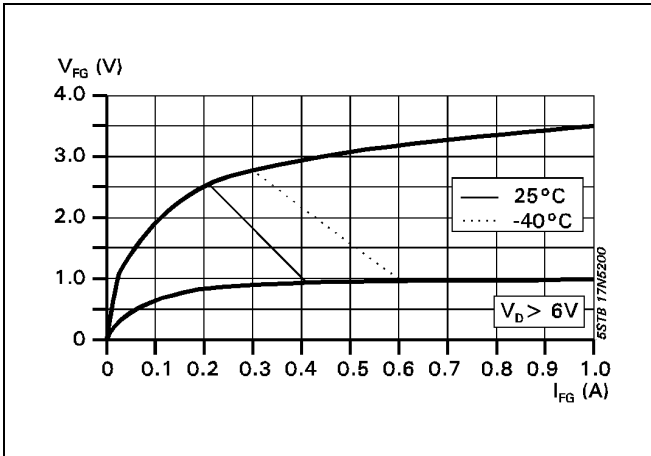

Fig. 8 Gate trigger characteristics.

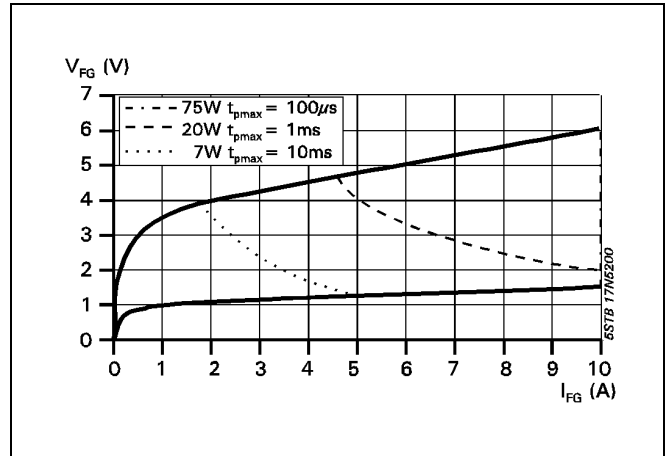

Fig. 9 Max. peak gate power loss.

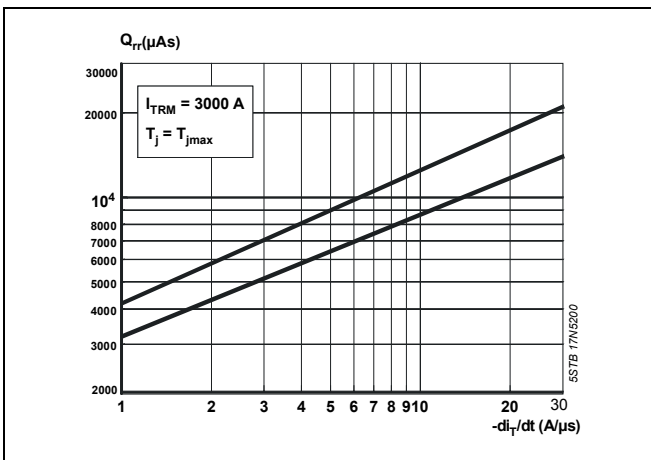

Fig. 10 Recovery charge vs. decay rate of on-state current.

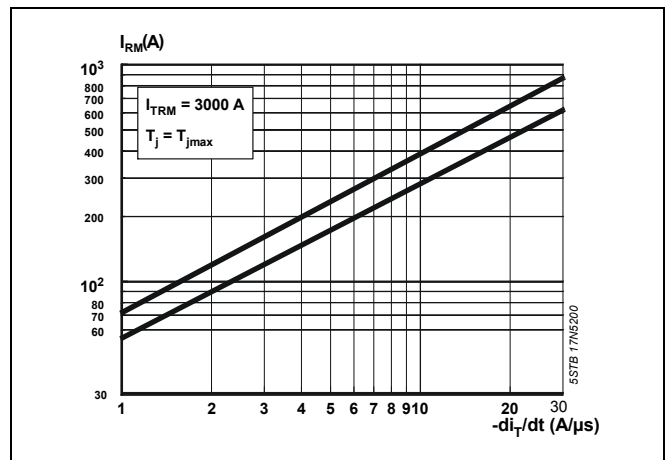

Fig. 11 Peak reverse recovery current vs. decay rate of on-state current.

Turn - off time, typical parameter relationship.

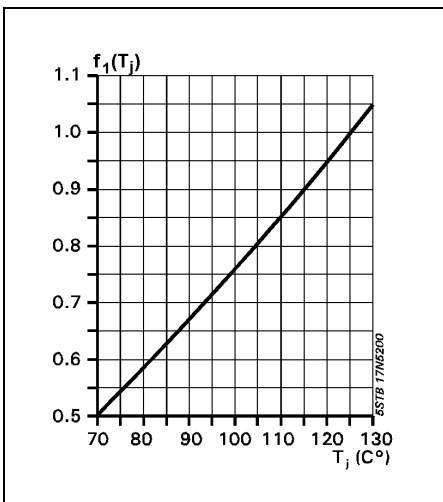

Fig. 12 $t_q/t_{q1} = f_1(T_j)$

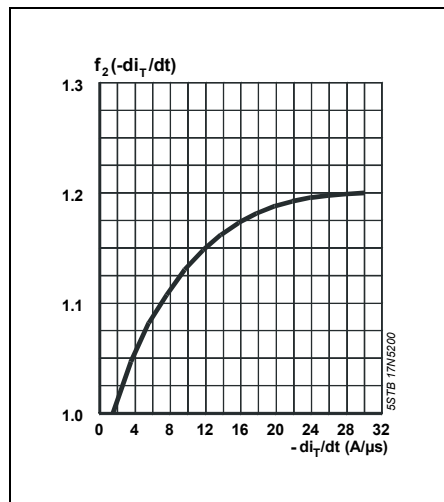

Fig. 13 $t_q/t_{q1} = f_2(-di_T/dt)$

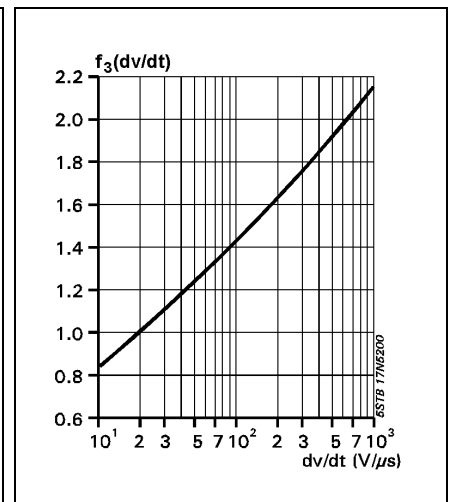

Fig. 14 $t_q/t_{q1} = f_3(dv/dt)$

$$t_q = t_{q1} \cdot f_1(T_j) \cdot f_2(-di_T/dt) \cdot f_3(dv/dt)$$

t_{q1} : at normalized values (see page 2)
 t_q : at varying conditions

Turn-on and Turn-off losses

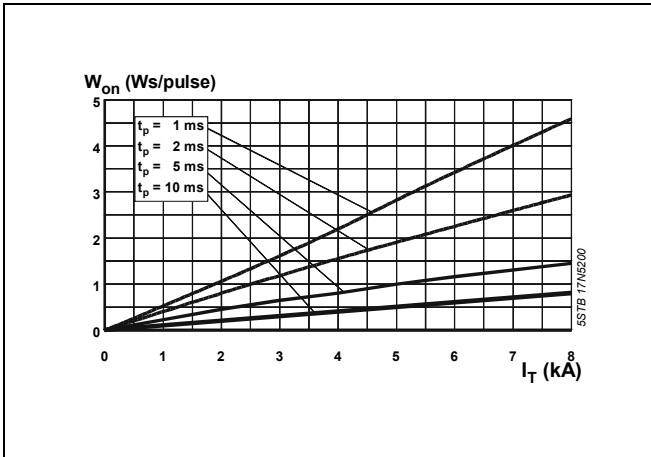

Fig. 15 $W_{on} = f(I_T, t_p)$, $T_j = 125\text{ }^\circ\text{C}$.
Half sinusoidal waves.

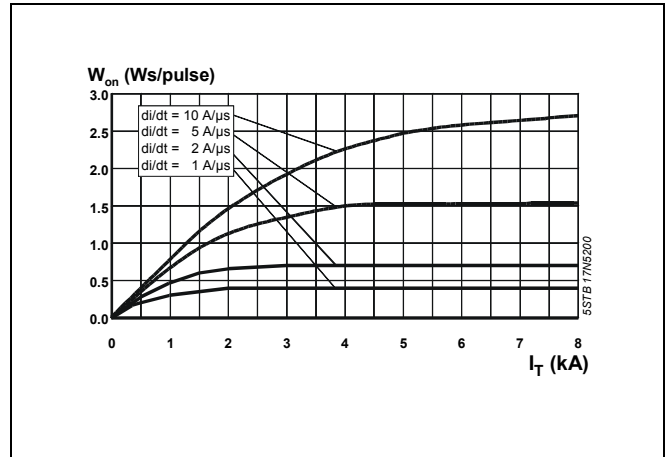

Fig. 16 $W_{on} = f(I_T, di/dt)$, $T_j = 125\text{ }^\circ\text{C}$.
Rectangular waves.

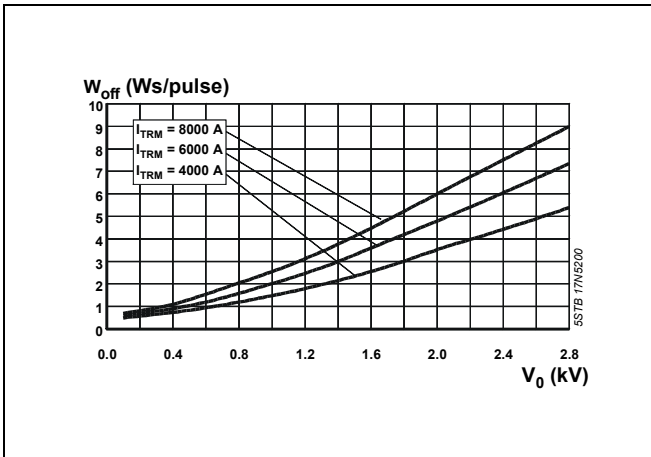

Fig. 17 $W_{off} = f(V_0, I_T)$, $T_j = 125\text{ }^\circ\text{C}$.
Half sinusoidal waves. $t_p = 10\text{ ms}$.

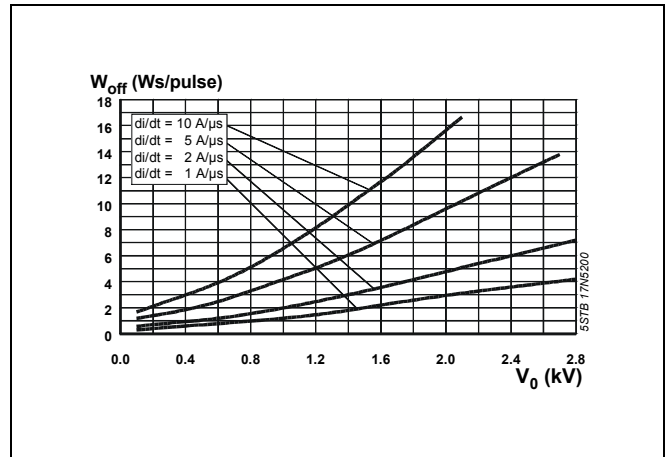

Fig. 18 $W_{off} = f(V_0, di/dt)$, $T_j = 125\text{ }^\circ\text{C}$.
Rectangular waves.

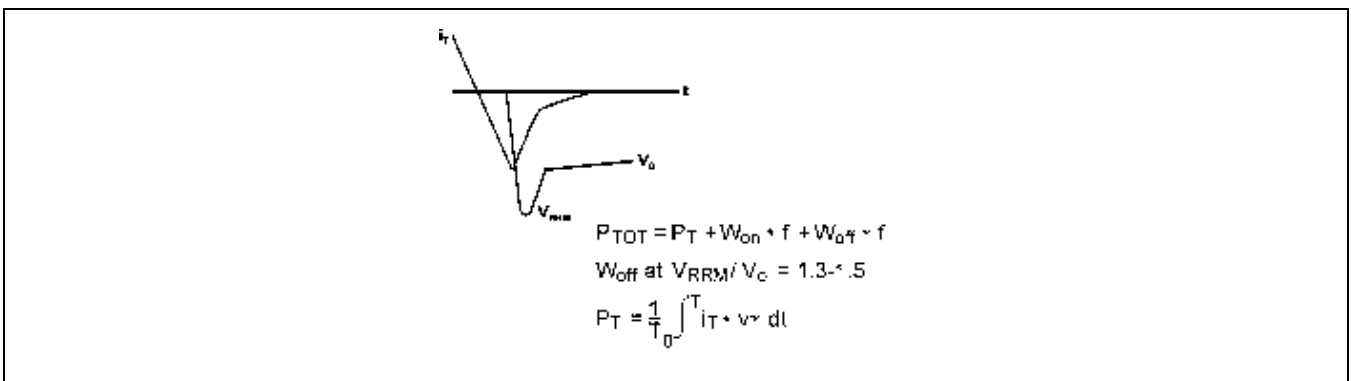

ABB Semiconductors AG reserves the right to change specifications without notice.



ABB Semiconductors AG
Fabrikstrasse 3
CH-5600 Lenzburg, Switzerland

Telephone +41 (0)62 888 6419
Fax +41 (0)62 888 6306
Email abbsem@ch.abb.com
Internet www.abbsem.com