

查询A19A52A0供应商

179-088 → 104

179-146 → 149

178-976 → 930

捷多邦, 专业PCB打样工厂, 24小时加急出货

The Fibre-Data Group

TERMINATED OPTICAL LEADS

& IN-LINE JOINERS

FROM

FARNELL ELECTRONIC COMPONENTS

fibre-data



FIBRE-DATA®

Unit 8, Pool Ind. Est., Druids Rd., Redruth, Cornwall, TR15 3RH.
Tele. (0209) 215424. Fax (0209) 215197. Telex 45273 FIBDAT G.

TECHNICAL INFORMATION SHEET

TERMINATED OPTICAL LEADS 200/250 micron cable.

INTRODUCTION

A range of high quality ready terminated optical patchcords utilising the latest state-of-the-art precision FSMA connectors, fitted, glued and polished to professional standards. The 200/250 micron all-glass fibre is specifically designed to provide a direct match with 200 micron P.C.S. (Plastic clad silica) fibre without the well known "grow-out" problems associated with short lengths of the P.C.S. type when connected. Its high numerical aperture makes it a useful medium power laser light guide.

TYPICAL FIBRE / CABLE SPECIFICATIONS

Core:	200 microns
Cladding:	250 microns
Numerical Aperture:	0.50
Attenuation of fibre:	2.4 dB/km max.
Overall Diameter:	3.5 mm
Outer Jacket:	Nylon
Strength Member:	Kevlar fibre
Minimum Bending Radius:	150 mm

TYPICAL CONNECTOR SPECIFICATIONS

Connector part No .	FSMA 257-255
Type FSMA - ceramic ferrule to draft MIL SPEC 83522	
Insertion loss per connector:	1.5 dB typical

FIBRE-DATA[®]

Unit 8, Pool Ind. Est., Druids Rd., Redruth, Cornwall, TR15 3RH.
Tele. (0209) 215424. Fax (0209) 215197. Telex 45273 FIBDAT G.

TECHNICAL INFORMATION SHEET

TERMINATED OPTICAL LEADS 50/125 micron cable.

INTRODUCTION

A range of high quality ready terminated optical patchcords utilising the latest state-of-the-art ceramic FSMA connectors, fitted and polished to professional standards. These articles are useful as point-to-point connectors or as an economical means of obtaining factory prepared pigtaills for fusion splicing. Two pigtaills are produced when a lead is cut in half.

TYPICAL FIBRE / CABLE SPECIFICATIONS

Core:	50 microns
Cladding:	125 microns
Numerical Aperture:	0.20
Attenuation of fibre:	3.0 dB/km
Overall Diameter:	3.2 mm
Outer Jacket:	P.V.C.
Strength Member:	Aramid Yarn
Minimum Bending Radius:	40 mm

TYPICAL CONNECTOR SPECIFICATIONS

Connector part No :	FSMA 154-128
Type FSMA - ceramic ferrule to draft MIL SPEC 83522	
In-line loss per pair:	1.5 dB typical

FIBRE-DATA[®]

Unit 8, Pool Ind. Est., Drulds Rd., Redruth, Cornwall, TR15 3RH.
Tele. (0209) 215424. Fax (0209) 215197. Telex 45273 FIBDAT G.

TERMINATED OPTICAL CABLES

INTRODUCTION

Fibre-data Terminated optical leads are offered by Farnell Electronic Components in recognition of the need to ensure consistent and reliable performance in a field of technology which is proliferating rapidly with the associated potential for reliability problems due to a shortage of long-term engineering experience. All these cable assemblies are not only assembled and prepared by very experienced operatives, but they are also produced and tested to some of the most exacting standards, using techniques specially developed to virtually eliminate the possibility of fibre damage during manufacture. All Fibre-data fibre optic assemblies are 100% tested prior to shipment and a permanent record is kept of all these results.

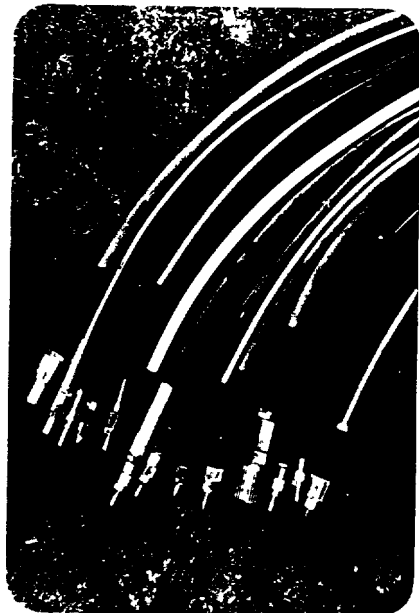

SUMMARY OF TYPES

50/125 Fibre.

Industry standard fibre particularly useful for installation companies requiring to fusion splice a series of pigtail connectors.

200/250 Fibre.

High Numerical aperture fibre with high light gathering capability. Totally compatible with 200 PCS (plastic clad silica) fibre and useful for the short haul to terminal links which often suffer from fibre mobility. (This does not occur with these glue and polish cables.) It is also a very useful laser fibre.

1000 (1mm) Polymer Fibre.

Ideal for short haul datalinks and industrial control applications. Plastic fibre is very difficult to terminate without damage and these optical leads therefore offer a significant advantage in terms of price, reliability and performance on systems such as RS232 data transmission.

FIBRE OPTIC IN LINE CONNECTORS

TYPE: FSMA

DESCRIPTION

FIBRE-DATA in-line FSMA joiners are designed to optimise the performance vs. price option. For large core fibres (200µ+) where ultra tight bore tolerances have only a minor effect on performance then the low cost 8005 series devices are recommended. For fibres such as 50µ and 62.5µ a highly accurate device is essential and the FDC series must be used.

IN-LINE PERFORMANCE

FIBRE TYPE

FDC 20/21 FSMA TYPES	50/125	62.5/125	85/125	100/140
LOSS	1.5dB typ 3.0dB max	1.5dB typ 3.0dB max	1.1dB typ 2.5dB max	1.0dB typ 2.5dB max

8005-20/21-Z-0 TYPES	BELOW 100µ core	200/250	200/380 PCS	1000µ polymer
LOSS	NOT RECOM- MENDED	2.0dB typ 4.0dB max	2.0dB typ (max not specified)	1.5dB typ 2.5dB max

- NOTES: 1) Figures specified relate to terminated connections of specified quality.
2) Max figures on PCS fibre cannot be quoted due to possible fibre mobility.

OUTLINE DIMENSIONS AND PANEL CUTOUTS

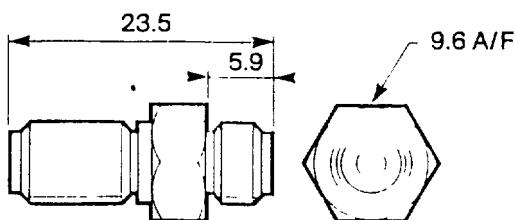

plug-to-plug line coupler

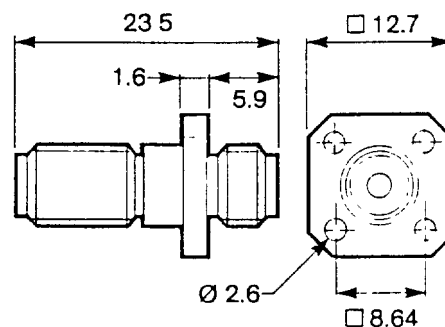

thru-bulkhead adaptor