



## ACT™ 1 Field Programmable Gate Arrays

T-46-19-11

### Features

- High Gate Count
  - A1010/A1010A: 1200 gate array gates (3000 PLD/LCA™ equivalent gates)
  - A1020/A1020A: 2000 gate array gates (6000 PLD/LCA equivalent gates)
- Instant Prototypes and Production
- Low-Power CMOS Technology
- Speed-Graded Devices Provide 15% to 25% Performance Improvement
- Toggle Rates to 100 MHz
- I/O Drive to 8 mA
- System-Level Performance to 40 MHz
- Gate Array Architecture Allows Completely Automatic Place and Route
- Nonvolatile, Permanent Programming
- Built-In Clock Distribution Network
- Built-In Diagnostic Probe Pins

### Description

The ACT 1 family of field programmable gate arrays (FPGAs) offers a variety of package, speed, and application combinations. Devices are implemented in silicon gate, 1.2-micron or 2-micron two-level metal CMOS, and they employ Actel's PLICE™ antifuse

technology. The unique architecture offers gate array flexibility, high performance, and instant turnaround through user programming. Device utilization is typically 95% of available logic modules.

ACT 1 devices also provide system designers with unique on-chip diagnostic probe capabilities, allowing convenient testing and debugging. Additional features include an on-chip clock driver with a hardwired distribution network. The network provides efficient clock distribution with minimum skew.

The user-definable I/Os are capable of driving at both TTL and CMOS drive levels. Available packages include plastic and ceramic J-leaded chip carriers, ceramic quad flatpack, and ceramic pin grid array.

A security fuse may be programmed to disable all further programming and to protect the design from being copied or reverse engineered.

### The Action Logic System

The ACT 1 device family is supported by Actel's Action Logic™ System, allowing logic design implementation with minimum effort. The Action Logic System (ALS) interfaces with the resident CAE system to provide a complete gate array design environment: schematic capture, simulation, fully automatic place and route, timing verification, and device programming. The Action Logic System is available for 386™ PC and for Apollo™ and Sun™ workstations, running Viewlogic®, Mentor Graphics®, Valid™, and OrCAD™.

### Product Family Profile

Device	CMOS Process	Applications	Speed Grades	Packages
A1010, A1020	2.0 μm	C, I, M, B	Standard	JQCC, CQFP, CPGA
A1010A, A1020A	1.2 μm	C, I, M, B	Standard, -1, -2	PLCC, JQCC, CQFP, CPGA

#### Important:

Contact your Actel representative for current availability. See Product Plan for package, speed grade, and application combinations.

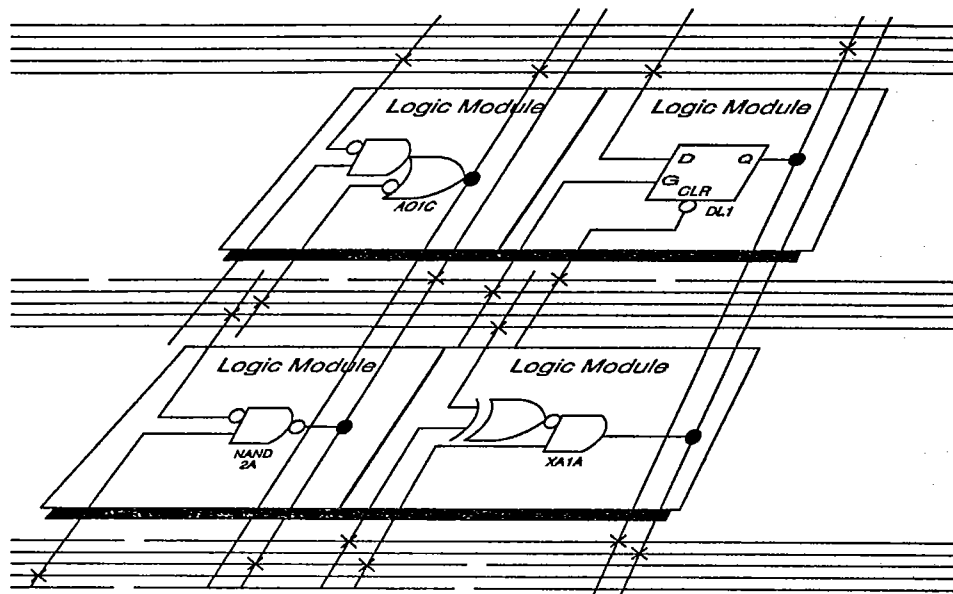

Figure 1. Partial View of an ACT 1 Device

## ACT 1 Device Structure

A partial view of an ACT 1 device (Figure 1 above) depicts four logic modules and distributed horizontal and vertical interconnect tracks. PLICE antifuses, located at intersections of the horizontal and vertical tracks, connect logic module inputs and outputs. During programming, these antifuses are addressed and programmed to make the connections required by the circuit application.

## The Actel Logic Module

The Actel logic module is an eight-input, one-output logic circuit chosen for the wide range of functions it implements and for its efficient use of interconnect routing resources.

The logic module can implement the four basic logic functions (NAND, AND, OR, and NOR) in gates of two, three, or four inputs. Each function may have many versions, with different combinations of active-low inputs. The logic module can also implement a variety of D-latches, exclusivity function, AND-ORs, and OR-ANDs. No dedicated hardwired latches or flip-flops are required in the array since latches and flip-flops may be constructed from logic modules wherever needed in the application.

## I/O Buffers

Each I/O pin is available as an input, output, three-state, or bidirectional buffer. Input and output levels are compatible with standard TTL and CMOS specifications. Outputs sink or source 4 mA at TTL levels. See Electrical Specifications for additional I/O buffer specifications.

## Device Organization

ACT 1 devices consist of a matrix of logic modules arranged in rows separated by wiring channels. This array is surrounded by a ring of peripheral circuits including I/O buffers, testability circuits, and diagnostic probe circuits providing real-time diagnostic capability. Between rows of logic modules are routing channels containing sets of segmented metal tracks with PLICE antifuses. Each channel has 22 signal tracks. Vertical routing is permitted via 13 vertical tracks per logic module column. The resulting network allows arbitrary and flexible interconnections between logic modules and I/O modules.

## Probe Pin

ACT 1 devices have two independent diagnostic probe pins. These pins allow the user to observe any two internal signals by entering the appropriate net name in the diagnostic software. Signals may be viewed on a logic analyzer using Actel's Actionprobe™ diagnostic tools. The probe pins can also be used as user-defined I/Os when debugging is finished.

## ACT 1 Array Performance

### Temperature and Voltage Effects

Worst-case delays for ACT 1 arrays are calculated in the same manner as for masked array products. A typical delay parameter is multiplied by a derating factor to account for temperature, voltage, and processing effects. However, in an ACT 1 array, temperature and voltage effects are less dramatic than with masked devices.

T-46-19-11

The electrical characteristics of module interconnections on ACT 1 devices remain constant over voltage and temperature fluctuations.

As a result, the total derating factor from typical to worst case for a standard speed ACT 1 array is only 1.19 to 1, compared to 2 to 1 for a masked gate array.

**Logic Module Size**

Logic module size also affects performance. A mask programmed gate array cell with four transistors usually implements only one logic level. In the more complex logic module (similar to the complexity of a gate array macro) of an ACT 1 array, implementation of multiple logic levels within a single module is possible. This eliminates interlevel wiring and associated RC delays. The effect is termed "net compression."

**Ordering Information**

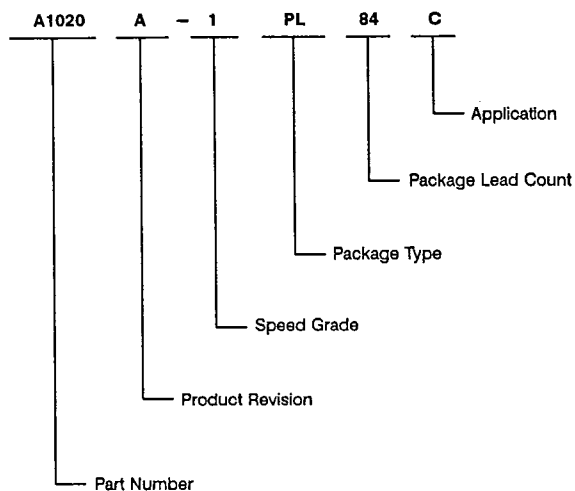

**Product Plan**

**A1010 and A1020 Devices**

	Speed Grade			Application			
	Std	-1	-2	C	I	M	B
<b>J-Leaded Cerquad Chip Carrier (JQ)</b>							
44-pin	✓	-	-	✓	✓	✓	✓
68-pin	✓	-	-	✓	✓	✓	✓
84-pin	✓	-	-	✓	✓	✓	✓
<b>Ceramic Quad Flatpack (CQ)</b>							
84-pin	✓	-	-	✓	✓	✓	✓
<b>Ceramic Pin Grid Array (PG)</b>							
84-pin	✓	-	-	✓	✓	✓	✓

**Important:** Before ordering, contact your Actel representative for current availability.

Applications: C = Commercial  
 I = Industrial  
 M = Military  
 B = 883B

Availability: ✓ = Available Now  
 P = Planned  
 - = Not Planned



ACTEL CORP

34E D

0192496 0000191 8 ACT

## Product Plan (continued)

T-46-19-11

## A1010A and A1020A Devices

	Speed Grade			Application			
	Std	-1	-2	C	I	M	B
<b>Plastic J-leaded Chip Carrier (PL)</b>							
44-pin	✓	✓	✓	✓	✓	-	-
68-pin	✓	✓	✓	✓	✓	-	-
84-pin	✓	✓	✓	✓	✓	-	-
<b>J-leaded Cerquad Chip Carrier (JQ)</b>							
44-pin	-	P	P	-	P	P	P
68-pin	-	P	P	-	P	P	P
84-pin	-	P	P	-	P	P	P
<b>Ceramic Quad Flatpack (CQ)</b>							
84-pin	-	P	P	-	P	P	P
<b>Ceramic Pin Grid Array (PG)</b>							
84-pin	-	P	P	-	P	P	P

**Important:** Before ordering, contact your Actel representative for current availability.

Applications: C = Commercial  
 I = Industrial  
 M = Military  
 B = 883B

Availability: ✓ = Available Now  
 P = Planned  
 - = Not Planned

T-46-19-11

**Device Resources**

Device Series	Modules	Gates	User I/Os				
			44 PL, JQ	68 PL, JQ	84 PL, JQ	84 CQ 84 PG	
A1010	295	1200	34	57	N/A	N/A	57
A1020	547	2000	34	57	69	69	69

**Absolute Maximum Ratings**

Free air temperature range

Symbol	Parameter	Limits	Units
V <sub>CC</sub>	DC Supply Voltage <sup>1</sup>	-0.5 to +7.0	Volts
V <sub>I</sub>	Input Voltage	-0.5 to V <sub>CC</sub> + 0.5	Volts
V <sub>O</sub>	Output Voltage	-0.5 to V <sub>CC</sub> + 0.5	Volts
I <sub>IK</sub>	Input Clamp Current	±20	mA
I <sub>OK</sub>	Output Clamp Current	±20	mA
I <sub>OK</sub>	Continuous Output Current	±25	mA
T <sub>STG</sub>	Storage Temperature	-65 to +150	°C

Stresses beyond those listed under "Absolute Maximum Ratings" may cause permanent damage to the device. Exposure to absolute maximum rated conditions for extended periods may affect device reliability. Device should not be operated outside the Recommended Operating Conditions.

Note:

- V<sub>PP</sub> = V<sub>CC</sub>, except during device programming.

**Recommended Operating Conditions**

Parameter	Commercial	Industrial	Military	Units
Temperature Range (Note 1)	0 to +70	-40 to +85	-55 to +125	°C
Power Supply Tolerance	±5	±10	±10	%V <sub>CC</sub>

Note:

- Ambient temperature (T<sub>A</sub>) used for commercial and industrial; case temperature (T<sub>C</sub>) used for military.

**Power Dissipation**

The following formula is used to calculate total device dissipation.

$$\text{Total Device Power (mW)} = (0.20 \times N \times F1) + (0.085 \times M \times F2) + (0.80 \times P \times F3)$$

Where:

- F1 = Average logic module switching rate in MHz.
- F2 = CLKBUF macro switching rate in MHz.
- F3 = Average I/O module switching rate in MHz.
- M = Number of logic modules connected to the CLKBUF macro.
- N = Total number of logic modules used in the design (including M).
- P = Number of outputs loaded with 50 pF.

Average switching rate of logic modules and of I/O modules is some fraction of the device operating frequency (usually CLKBUF). Logic modules and I/O modules switch states (from low-to-high or from high-to-low) only if the input data changes when the module is enabled. A conservative estimate for average logic module and I/O module switching rates (variables F1 and F3, respectively) is 10% of device clock driver frequency.

If the CLKBUF macro is not used in the design, eliminate the second term (including F2 and M variables) from the formula.

**Sample A1020 Device Power Calculation**

To illustrate the power calculation, consider a large design operating at high frequency. This sample design utilizes 85% of available logic modules on the A1020-series device (.85 x 547 = 465 logic modules used). The design contains 104 flip-flops (208 logic modules). Operating frequency of the design is 16 MHz. In this design, the CLKBUF macro drives the clock network. Logic modules and I/O modules are switching states at approximately 10% of the clock frequency rate (.10 x 16 MHz = 1.6 MHz). Sixteen outputs are loaded with 50 pF.

To summarize the design described above: N = 464; M = 208; F2 = 16; F1 = 4; F3 = 4; P = 16. Total device power can be calculated by substituting these values for variables in the device dissipation formula.

Total device power for this example =

$$(0.20 \times 465 \times 1.6) + (0.085 \times 208 \times 16) + (0.80 \times 16 \times 1.6) = 452 \text{ mW}$$



**Electrical Specifications**

Parameter	Commercial		Industrial		Military		Units
	Min.	Max.	Min.	Max.	Min.	Max.	
$V_{OH}^1$	3.84						V
	(I <sub>OH</sub> = -4 mA)						
			3.7		3.7		V
$V_{OL}^1$			0.33		0.40		V
			(I <sub>OL</sub> = 4 mA)				
$V_{IL}$	-0.3	0.8	-0.3	0.8	-0.3	0.8	V
$V_{IH}$	2.0	$V_{CC} + 0.3$	2.0	$V_{CC} + 0.3$	2.0	$V_{CC} + 0.3$	V
Input Transition Time $t_r, t_f^2$	500		500		500		ns
$C_{IO}$ I/O Capacitance <sup>2, 3</sup>	10		10		10		pF
Standby Current, $I_{CC}^4$	10		20		25		mA
Leakage Current <sup>5</sup>	-10	10	-10	10	-10	10	μA
$I_{OS}$ Output Short Circuit Current <sup>6</sup>	(V <sub>O</sub> = V <sub>CC</sub> )		20		140		mA
	(V <sub>O</sub> = GND)		-10		-100		mA

Notes:

1. Only one output tested at a time. V<sub>CC</sub> = min.
2. Not tested, for information only.
3. Includes worst-case 84-pin PLCC package capacitance. V<sub>OUT</sub> = 0 V, f = 1 MHz.
4. Typical standby current = 3 mA. All outputs unloaded. All inputs = V<sub>CC</sub> or GND.
5. V<sub>O</sub>, V<sub>IN</sub> = V<sub>CC</sub> or GND.
6. Only one output tested at a time. Min. at V<sub>CC</sub> = 4.5 V; Max. at V<sub>CC</sub> = 5.5 V.

**Package Thermal Characteristics**

The device junction to case thermal characteristic is  $\theta_{jc}$ , and the junction to ambient air characteristic is  $\theta_{ja}$ . The thermal characteristics for  $\theta_{ja}$  are shown with two different air flow rates.

Maximum junction temperature is 150°C.

A sample calculation of the maximum power dissipation for an 84-pin ceramic pin grid array at military temperature is as follows:

$$\frac{\text{Max. junction temp. (°C)} - \text{Max. military temp. (°C)}}{\theta_{ja} \text{ (°C/W)}} = \frac{150^\circ\text{C} - 125^\circ\text{C}}{33^\circ\text{C/W}} = 0.76 \text{ W}$$

Package Type	Pin Count	$\theta_{jc}$	$\theta_{ja}$ Still air	$\theta_{ja}$ 300 ft/min.	Units
Plastic J-leaded Chip Carrier	44	15	52	40	°C/W
	68	13	45	35	°C/W
	84	12	44	33	°C/W
Cerquad J-leaded Chip Carrier	44	8	38	30	°C/W
	68	8	35	25	°C/W
	84	8	34	24	°C/W
Ceramic Quad Flatpack	84	5	40	30	°C/W
Ceramic Pin Grid Array	84	8	33	20	°C/W

T-46-19-11

**AC Test Specifications**

$V_{CC} = 5.0\text{ V}; T_A = 25^\circ\text{C}$

Parameter	Min.	Max.	Units
<b>Binning Circuit Delay (<math>t_{PD}</math>)</b>			
A1010		87	ns
A1010A			
Standard Speed		87	ns
-1 Speed Grade		72	ns
-2 Speed Grade		65	ns
A1020		135	ns
A1020A			
Standard Speed		135	ns
-1 Speed Grade		112	ns
-2 Speed Grade		101	ns

**Functional Timing Tests**

AC timing for logic module internal delays is determined after place and route. The ALS Timer utility displays actual timing parameters for circuit delays. ACT 1 devices are AC tested to a "binning" circuit specification.

The circuit consists of one input buffer + n logic modules + one output buffer (n = 16 for A1010/A1010A; n = 28 for A1020/A1020A). The logic modules are distributed along two sides of the device, as inverting or non-inverting buffers. The modules are connected through programmed antifuses with typical capacitive loading.

Propagation delay [ $t_{PD} = (t_{PLH} + t_{PHL})/2$ ] is tested to the following AC test specifications.

**Output Buffer Performance Derating**

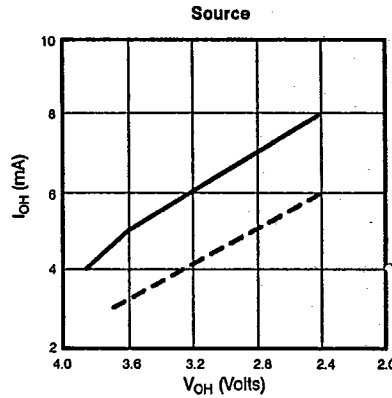
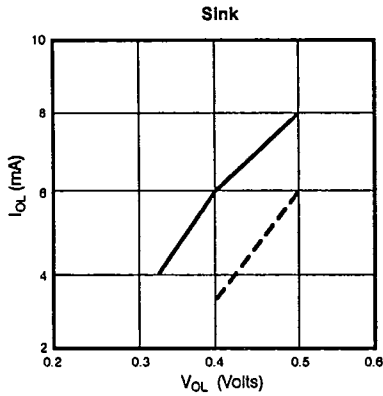

--- Military, worst case values at 125°C, 4.5 V.  
 — Commercial, worst case values at 70°C, 4.75 V.

**Note:**

The above curves are based on characterizations of sample devices and are not completely tested on all devices.



### Timing Characteristics

Timing is design-dependent; actual delay values are determined after place and route of the design using the ALS Timer utility. The following delay values use statistical estimates for wiring delays based on 85% to 90% module utilization. Device utilization above 95% will result in performance degradation.

With ALS place and route programs, the user can assign criticality level to a net, based on timing requirements. Delays for both typical

and critical (speed-sensitive) nets are given below. Most nets will fall into the "typical" category.

Less than 1% of all routing in a design requires the use of "long tracks." Long tracks, long vertical or horizontal routing paths, are used by the autorouter only as needed. Delays due to the use of long tracks range from 15 ns to 35 ns. Long tracks may be used to route the least-critical nets in a given design.

T-46-19-11

### Logic Module Timing

$V_{CC} = 5.0\text{ V}$ ;  $T_A = 25^\circ\text{C}$ ; Process = Typical;  $t_{PD} = 3.0\text{ ns @ FO} = 0$

#### Single Logic Module Macros (e.g., most gates, latches, multiplexors)<sup>1</sup>

Parameter	Output Net	FO = 1	FO = 2	FO = 3	FO = 4	FO = 8	Units
$t_{PD}$	Critical	5.4	5.8	6.2	8.5	Note 2	ns
$t_{PD}$	Typical	6.3	6.7	7.7	8.6	10.8	ns

#### Dual Logic Module Macros (e.g., adders, wide input gates)<sup>1</sup>

Parameter	Output Net	FO = 1	FO = 2	FO = 3	FO = 4	FO = 8	Units
$t_{PD}$	Critical	9.2	9.6	10.0	12.3	Note 2	ns
$t_{PD}$	Typical	10.2	10.6	11.6	12.5	14.6	ns

#### Sequential Element Timing Characteristics

Parameter		Fan-Out					Units
		FO = 1	FO = 2	FO = 3	FO = 4	FO = 8	
$t_{SU}$	Set Up Time, Data Latches	3.5	3.9	4.2	4.5	4.8	ns
$t_{SU}$	Set Up Time, Flip-Flops	3.9	3.9	3.9	3.9	3.9	ns
$t_H$	Hold Time	0	0	0	0	0	ns
$t_W$	Pulse Width, Minimum <sup>3</sup>	7.7	8.5	9.2	10.0	14.0	ns
$t_{CO}$	Delay, Critical Net	5.4	5.8	6.2	8.5	Note 2	ns
$t_{CO}$	Delay, Typical Net	6.3	6.7	7.7	8.6	10.8	ns

**Notes:**

1. Most flip-flops exhibit single module delays.
2. Critical nets have a maximum fan-out of 6.
3. Minimum pulse width,  $t_W$ , applies to CLK, PRE, and CLR inputs.



T-46-19-11

I/O Buffer Timing

V<sub>CC</sub> = 5.0 V; T<sub>A</sub> = 25°C; Process = Typical

INBUF Macros

Parameter	From - To	FO = 1	FO = 2	FO = 3	FO = 4	FO = 8	Units
t <sub>PHL</sub>	Pad to Y	6.9	7.6	8.9	10.7	14.3	ns
t <sub>PLH</sub>	Pad to Y	5.9	6.5	7.7	8.4	12.4	ns

CLKBUF (High Fan-Out Clock Buffer) Macros

Parameter	FO = 40	FO = 160	FO = 320	Units
t <sub>PHL</sub>	9.0	12.0	15.0	ns
t <sub>PLH</sub>	9.0	12.0	15.0	ns

Notes:

1. A clock balancing feature is provided to minimize clock skew.
2. There is no limit to the number of loads that may be connected to the CLKBUF macro.

OUTBUF, TRIBUFF & BIBUF Macros

C<sub>L</sub> = 50 pF

Parameter	From - To	CMOS	TTL	Units
t <sub>PHL</sub>	D to Pad	3.9	4.9	ns
t <sub>PLH</sub>	D to Pad	7.2	5.7	ns
t <sub>PHZ</sub>	E to Pad	5.2	3.4	ns
t <sub>PZH</sub>	E to Pad	6.5	4.9	ns
t <sub>PLZ</sub>	E to Pad	6.9	5.2	ns
t <sub>PZL</sub>	E to Pad	4.9	5.9	ns

Change in Propagation Delay with Load Capacitance

Parameter	From - To	CMOS	TTL	Units
t <sub>PHL</sub>	D to Pad	0.03	0.046	ns/pF
t <sub>PLH</sub>	D to Pad	0.07	0.039	ns/pF
t <sub>PHZ</sub>	E to Pad	0.08	0.046	ns/pF
t <sub>PZH</sub>	E to Pad	0.07	0.039	ns/pF
t <sub>PLZ</sub>	E to Pad	0.07	0.039	ns/pF
t <sub>PZL</sub>	E to Pad	0.03	0.039	ns/pF

Notes:

1. The BIBUF macro input section exhibits the same delays as the INBUF macro.
2. Load capacitance delay delta can be extrapolated down to 15 pF minimum.  
 Example:  
 Delay for OUTBUF driving a 100-pF TTL load:  
 $t_{PHL} = 4.9 + (.046 \times (100-50)) = 4.9 + 2.3 = 7.2 \text{ ns}$   
 $t_{PLH} = 5.7 + (.039 \times (100-50)) = 5.7 + 2.0 = 7.7 \text{ ns}$

## Timing Derating

Operating temperature, operating voltage and device processing conditions, along with device die size and speed grade, account for variations in array timing characteristics. These variations are summarized into a derating factor for ACT 1 array typical timing

specifications. The derating factors shown in the table below are based on the recommended operating conditions for ACT 1 commercial, industrial, and military applications. The derating curves show worst-to-best case operating voltage range and best-to-worst case operating temperature range.

### Timing Derating Factor (x typical)

Device	Commercial		Industrial		Military	
	Best Case	Worst Case	Best Case	Worst Case	Best Case	Worst Case
A1010, A1020	0.45	1.54	0.40	1.65	0.37	1.79
A1010A, A1020A						
Standard Speed	0.45	1.54	0.40	1.65	0.37	1.79
-1 Speed Grade	0.45	1.28	0.40	1.37	0.37	1.49
-2 Speed Grade	0.45	1.13	0.40	1.20	0.37	1.32

#### Note:

Best case reflects maximum operating voltage, minimum operating temperature, and best case processing. Worst case reflects minimum operating

voltage, maximum operating temperature, and worst case processing. Best case derating is based on sample data only and is not guaranteed.

T-46-19-11

#### Voltage Derating Curve

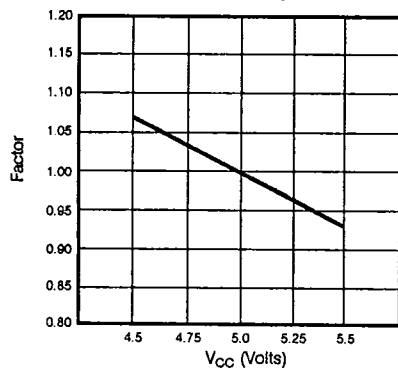

#### Temperature Derating Curve

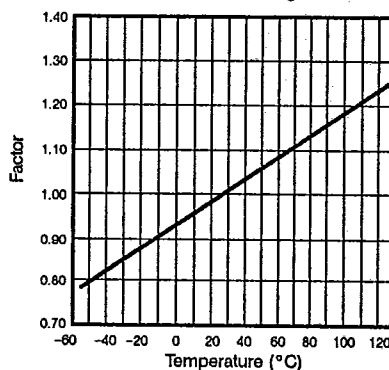

## Output Buffer Delays

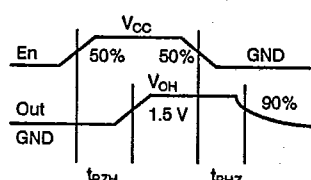
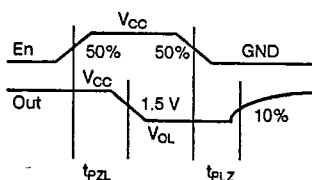
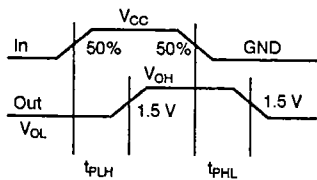

T-46-19-11

AC Test Loads

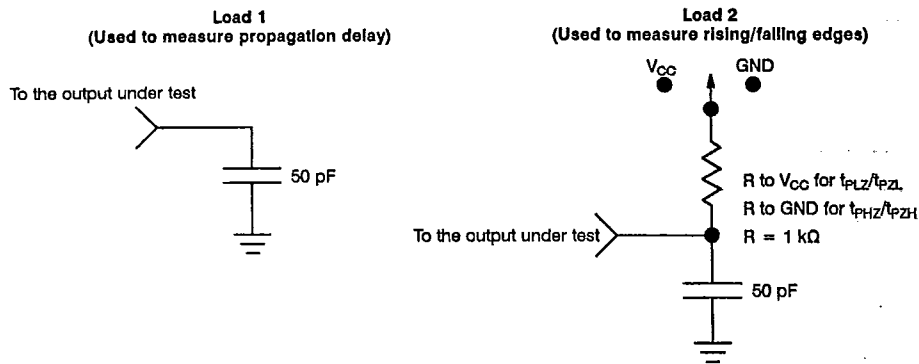

Input Buffer Delays

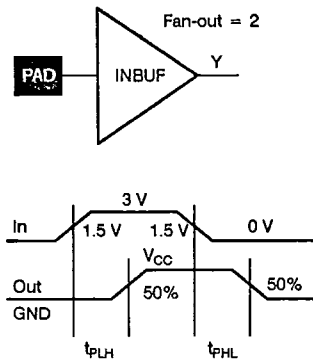

Module Delays

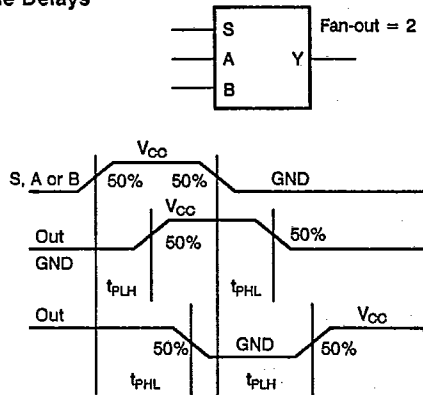

D-Type Flip-Flop and Clock Delays

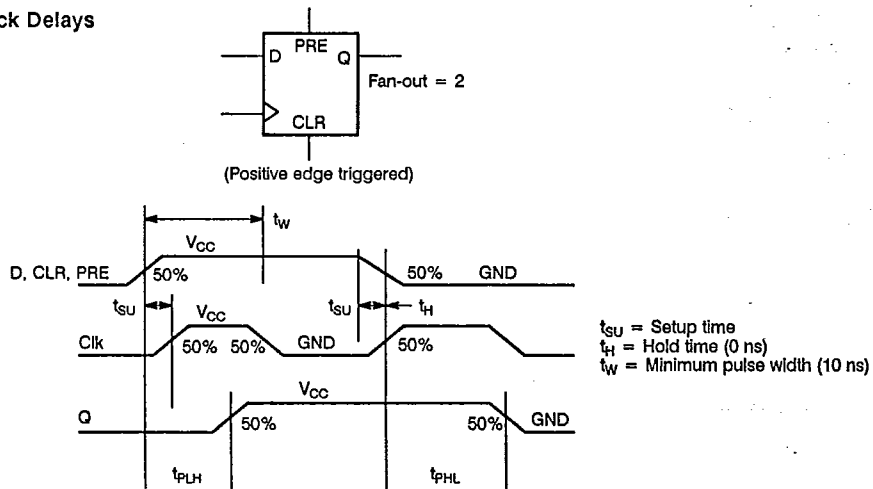



T-46-19-11

ACTEL CORP  
Soft Macro Library Overview

34E D 0192496 0000199 2 ACT

Macro Name	Modules Req'd	Description	Levels of Logic
<b>Counters</b>			
CNT4A	17	4 bit loadable binary counter with clear	4
CNT4B	15	4 bit loadable bin counter w/ clr, active low carry in & carry out	4
UDCNT4A	24	4 bit up/down cntr w/ sync active low load, carry in & carry out	6
<b>Decoders</b>			
DEC2X4	4	2 to 4 decoder	1
DEC2X4A	4	2 to 4 decoder with active low outputs	1
DEC3X8	8	3 to 8 decoder	1
DEC3X8A	8	3 to 8 decoder with active low outputs	1
DEC4X16A	20	4 to 16 decoder with active low outputs	2
DECE2X4	4	2 to 4 decoder with enable	1
DECE2X4A	4	2 to 4 decoder with enable and active low outputs	1
DECE3X8	11	3 to 8 decoder with enable	2
DECE3X8A	11	3 to 8 decoder with enable and active low outputs	2
<b>Latches and Registers</b>			
DLC8A	8	Octal latch with clear	1
DLE8	8	Octal latch with enable	1
DLM8	8	Octal latch with multiplexed inputs	1
REGE8A	20	Octal register with preset and clear, active high enable	2
REGE8B	20	Octal register w/ active low clock, preset & clear, active high en.	2
<b>Adders</b>			
FA1	3	One bit full adder	3
FADD8	37	8 bit fast adder	4
FADD12	62	12 bit fast adder	5
FADD16	78	16 bit fast adder	5
FADD24	120	24 bit fast adder	6
FADD32	160	32 bit fast adder	7
<b>Comparators</b>			
ICMP4	5	4 bit identity comparator	2
ICMP8	9	8 bit identity comparator	3
MCMP16	93	16 bit magnitude comparator	5
MCMPC2	9	2 bit magnitude comparator with enables	3
MCMPC4	18	4 bit magnitude comparator with enables	4
MCMPC8	36	8 bit magnitude comparator with enables	6
<b>Multiplexors</b>			
MX8	3	8 to 1 multiplexor	2
MX8A	3	8 to 1 multiplexor with an active low output	2
MX16	5	16 to 1 multiplexor	2
<b>Multipliers</b>			
SMULT8	235	8 x 8 two's complement multiplier	Varies

T-46-19-11

## Soft Macro Library Overview (continued)

Macro Name	Modules Req'd	Description	Levels of Logic
<b>Shift Registers</b>			
SREG4A	8	4 bit shift register with clear	2
SREG8A	18	8 bit shift register with clear	2
<b>TTL Replacements</b>			
TA138	12	3 to 8 decoder with 3 enables and active low outputs	2
TA139	4	2 to 4 decoder with an enable and active low outputs	1
TA151	5	8 to 1 multiplexor with enable, true, and complementary outputs	3
TA153	2	4 to 1 multiplexor with active low enable	2
TA157	1	2 to 1 multiplexor with enable	1
TA161	22	4 bit sync counter w/ load, clear, count enables & ripple carry out	3
TA164	18	8 bit serial in, parallel out shift register	1
TA169	25	4 bit synchronous up / down counter	6
TA181	31	4 bit ALU	4
TA194	14	4 bit shift register	1
TA195	10	4 bit shift register	1
TA269	50	8 bit up/down cntr w/ clear, load, ripple carry output & enables	8
TA273	18	Octal register with clear	1
TA280	9	Parity generator and checker	4
TA377	16	Octal register with active low enable	1
<b>Super Macros</b>			
UART	189	Universal Asynchronous Receiver / Transmitter	7-Tx 4-Rx
MC	102	DRAM Controller	Varies
DMA	225	Direct Memory Access Controller	Varies
SINT	180	SCSI Interface Controller	Varies

T-46-19-11

**Hard Macro Library Overview**

The following illustrations show all the available Hard Macros.

**2-Input Gates (Module Count = 1)**

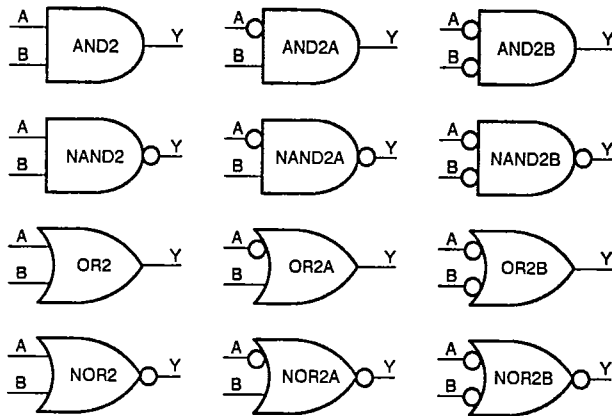

**3-Input Gates (Module Count = 1, unless indicated otherwise)**

② Indicates 2-module macro  
▲ Indicates extra delay input

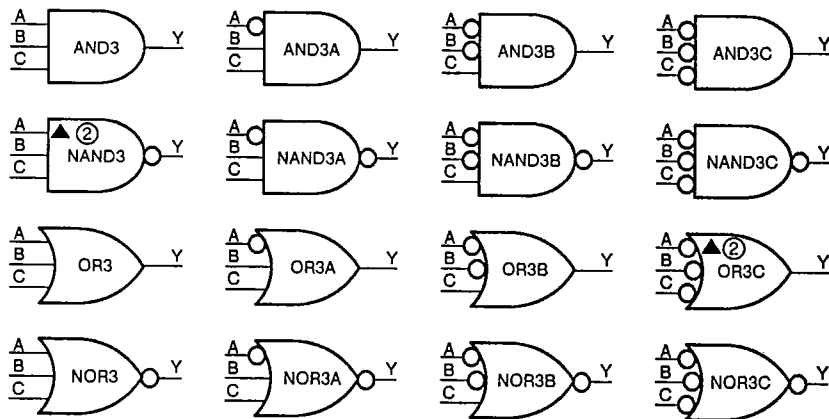

T-46-19-11

4-Input Gates (Module Count = 1, unless indicated otherwise)

② Indicates 2-module macro  
▲ Indicates extra delay input

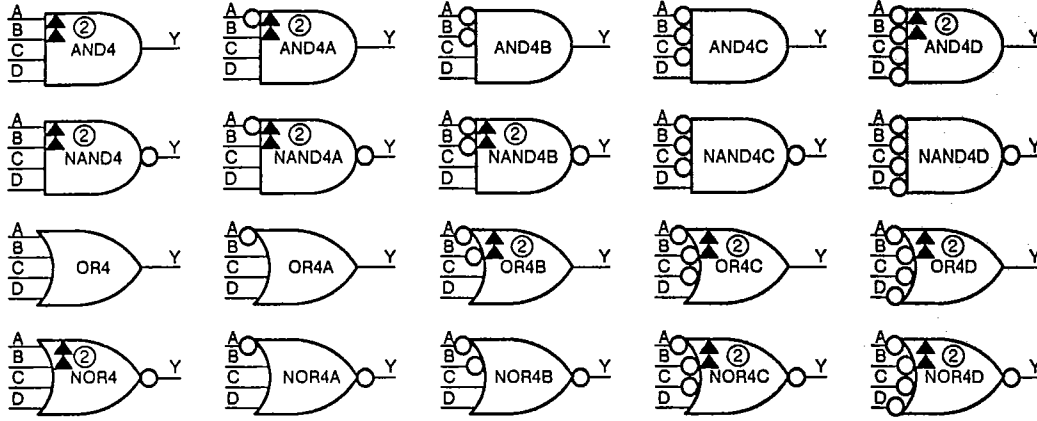

XOR Gates

(Module Count = 1)

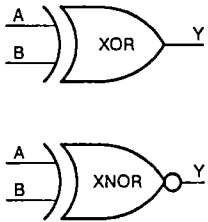

XOR OR Gates

(Module Count = 1)

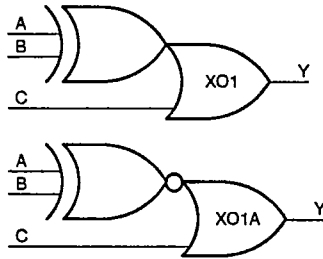

XOR AND Gates

(Module Count = 1)

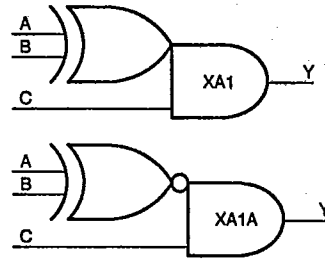

AND XOR Gates

(Module Count = 1)

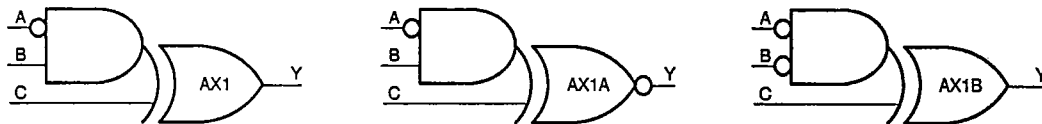

AND OR Gates (Module Count = 1)

② Indicates 2-module macro  
 ▲ Indicates extra delay input

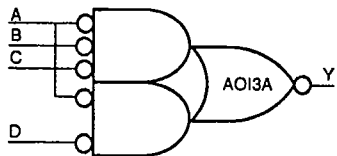
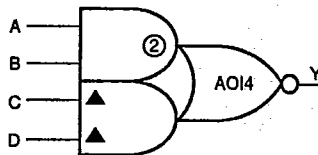
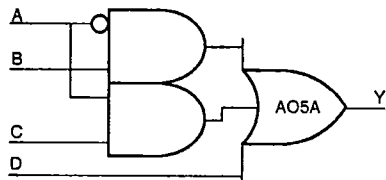
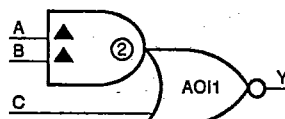
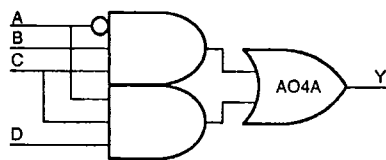
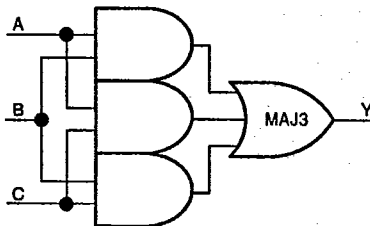
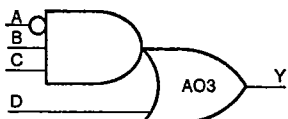
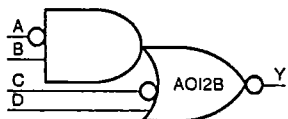
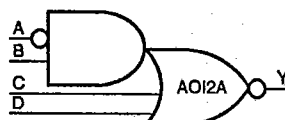
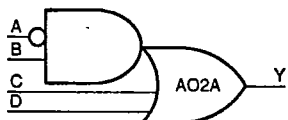
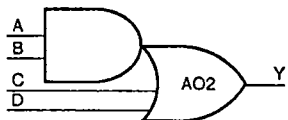
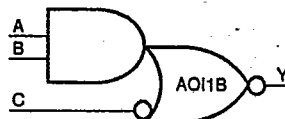
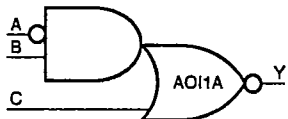
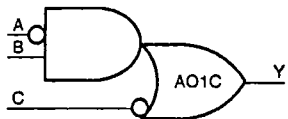
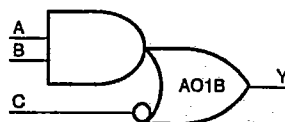
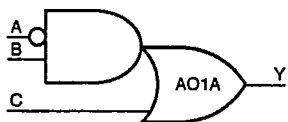
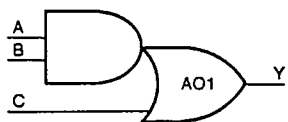



OR AND Gates (Module Count = 1)

② Indicates 2-module macro  
▲ Indicates extra delay input

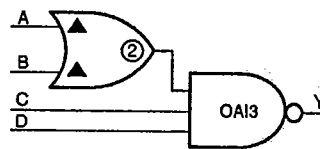
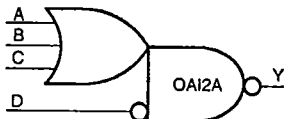
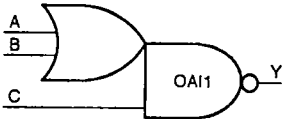
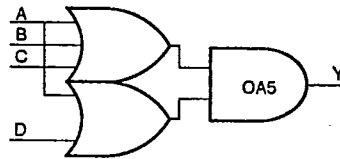
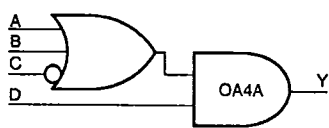
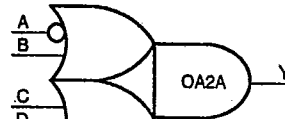
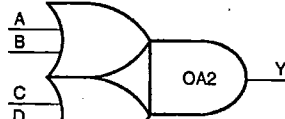
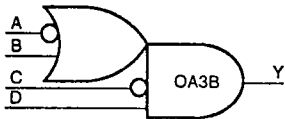
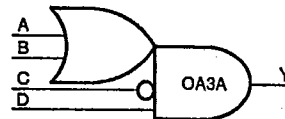
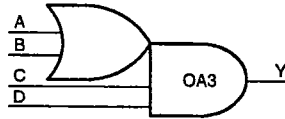
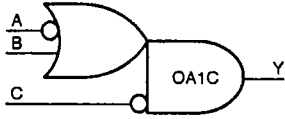
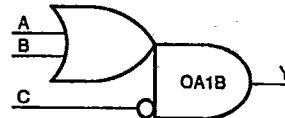
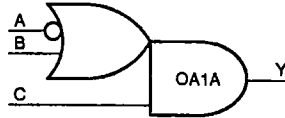
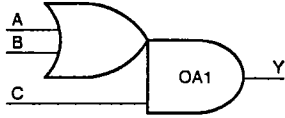

Buffers (Module Count = 1)

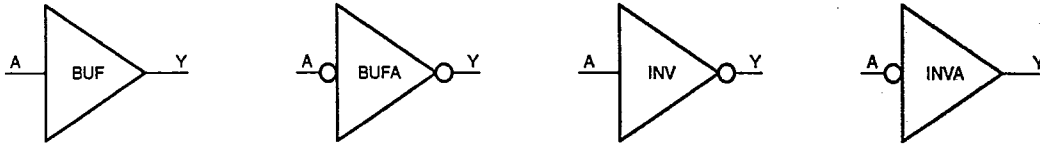

I/O Buffers (I/O Module Count = 1)

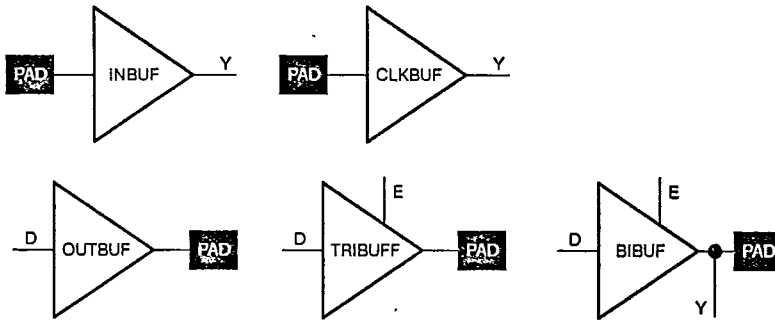

Multiplexors (Module Count = 1)

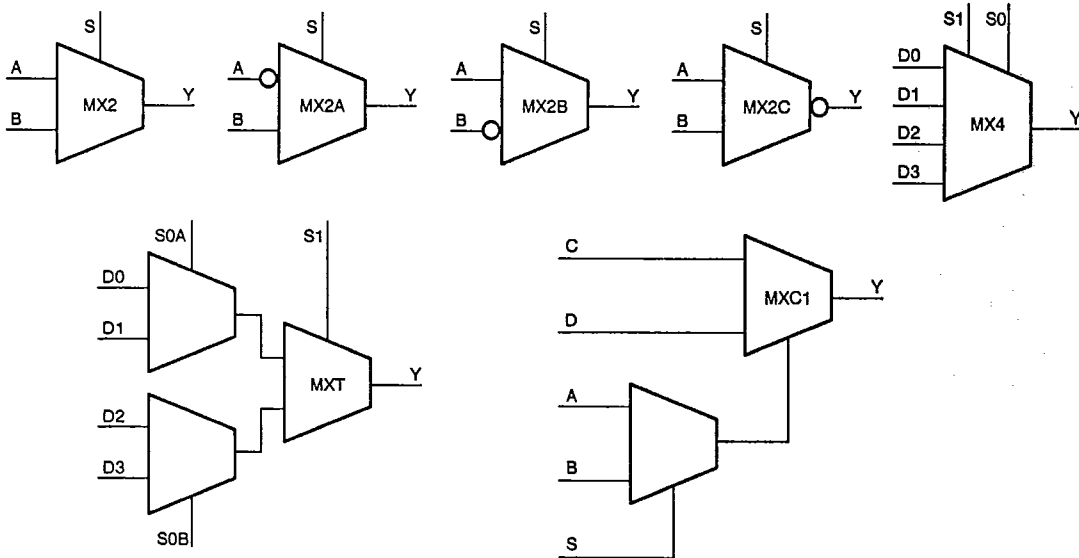

Latches (Module Count = 1)

T-46-19-11

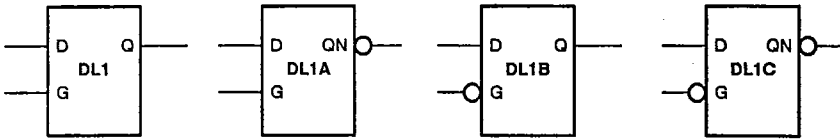

D Latches with Clear (Module Count = 1)

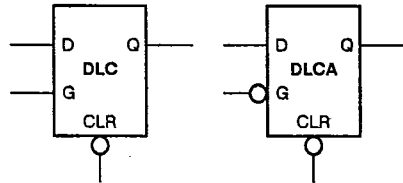

D Latches with Enable (Module Count = 1)

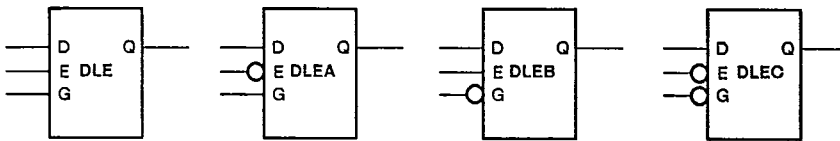

Mux Latches (Module Count = 1)

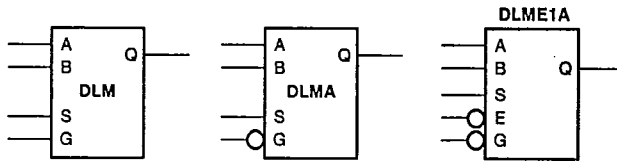

Adders (Module Count = 2)

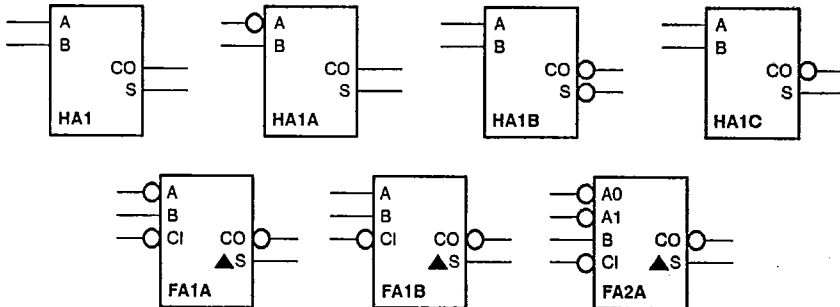

Macros FA1A, FA1B, and FA2A have two level delays from the inputs to the S outputs, as indicated by the ▲

D Flip-Flops (Module Count = 2)

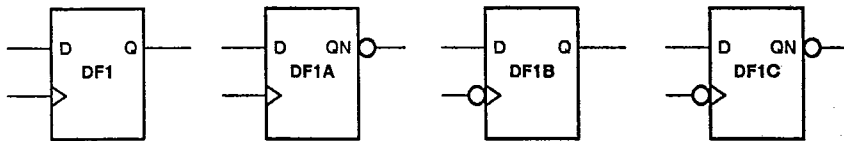

D Flip-Flops with Clear

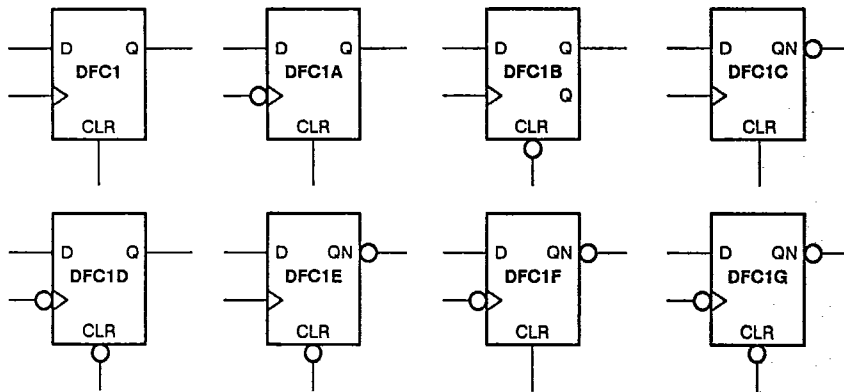

D Flip-Flops with Preset

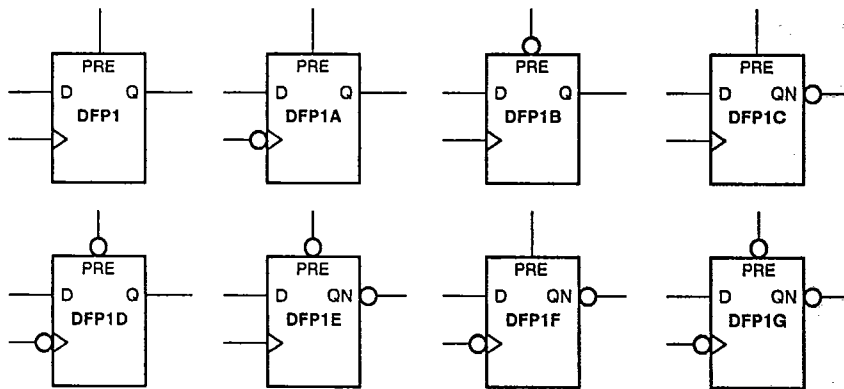

D Flip-Flops with Preset and Clear

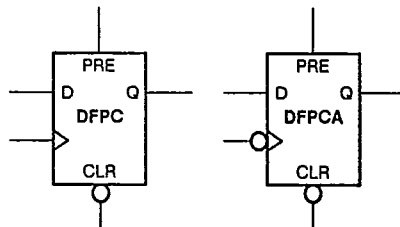

T-46-19-11

D Flip-Flops with Enable (Module Count = 2)

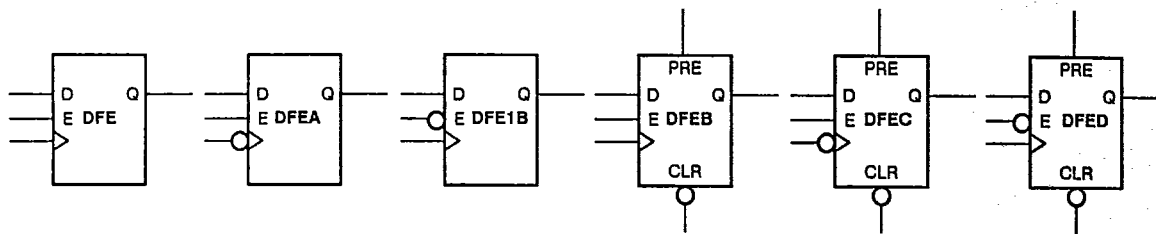

JK Flip-Flops (Module Count = 2)

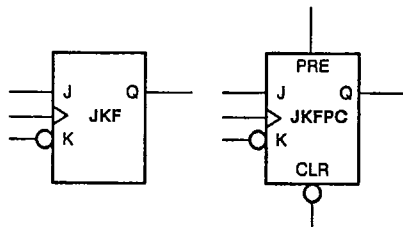

Mux Flip-Flops (Module Count = 2)

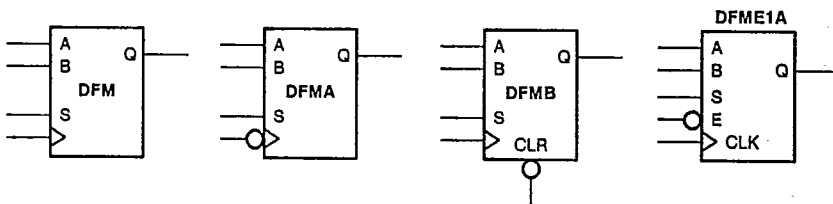

CLKBUF Interface Macros (Module Count = 1)

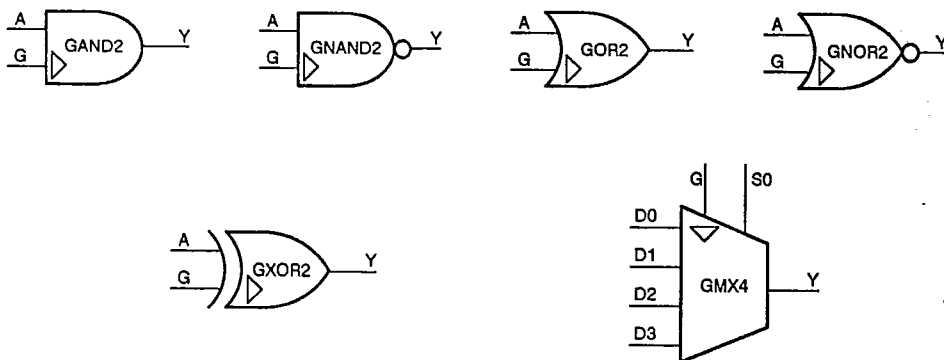



Package Pin Assignments (continued)

T-46-19-11

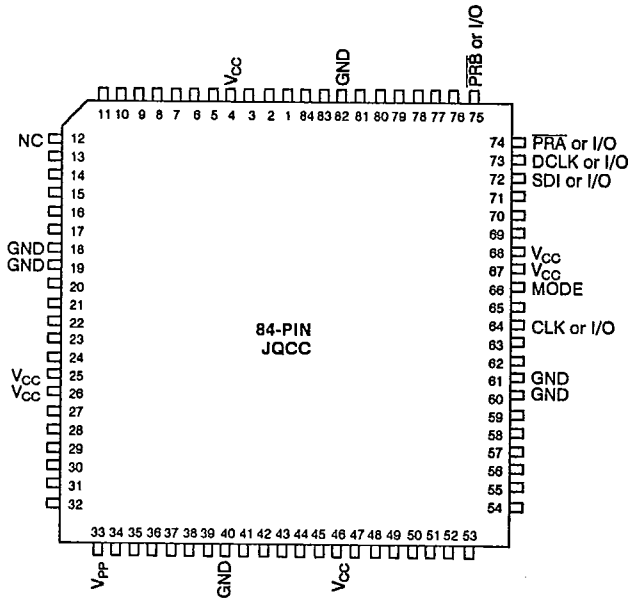
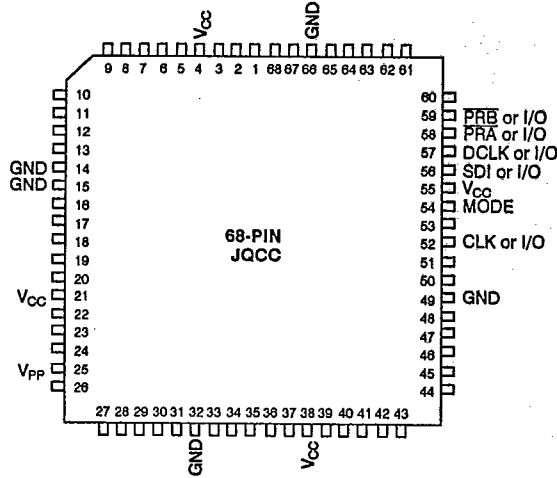
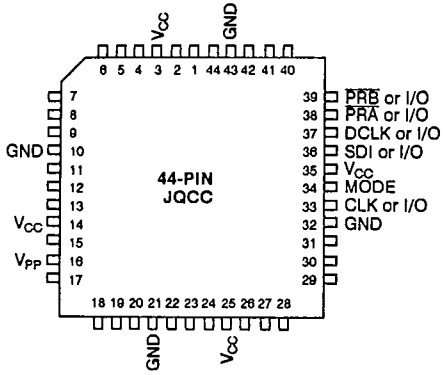

Notes:

1. Vpp must be terminated to Vcc, except during device programming.
2. MODE must be terminated to circuit ground, except during device programming or debugging.
3. Unused I/O pins are designated as outputs by the Action Logic System and are driven low.
4. All unassigned pins are available for use as I/Os.

Package Pin Assignments (continued)

T-46-19-11

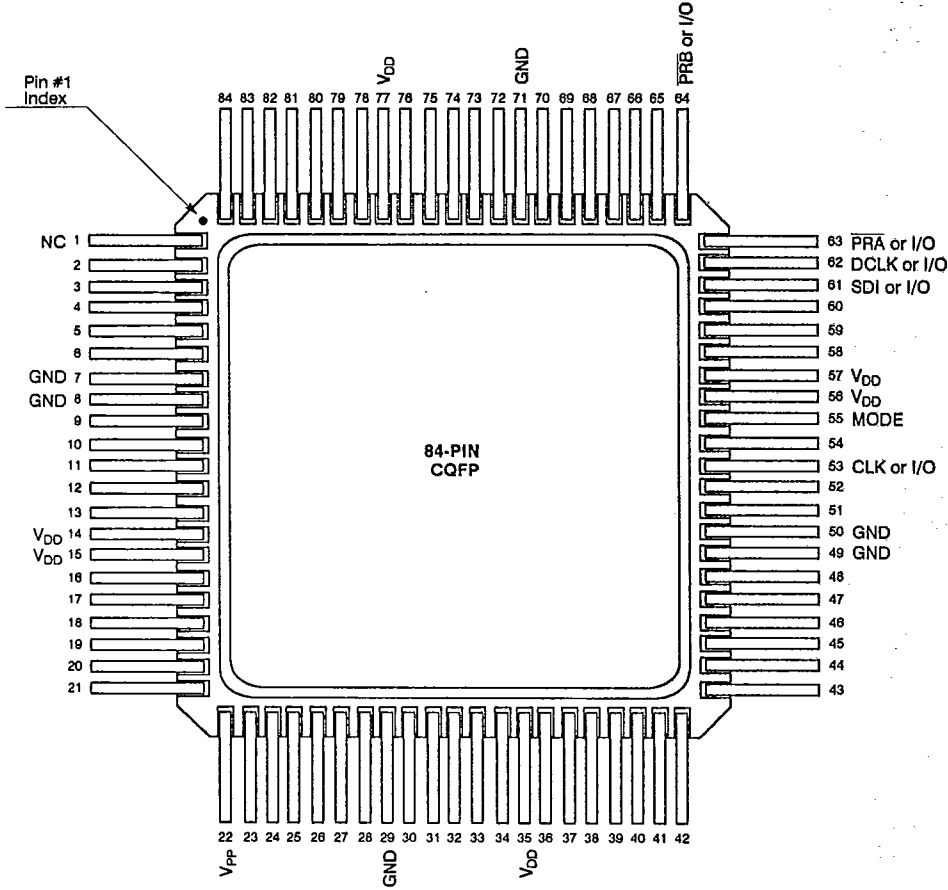

Notes:

1. V<sub>PP</sub> must be terminated to V<sub>CC</sub>, except during device programming.
2. MODE must be terminated to circuit ground, except during device programming or debugging.
3. Unused I/O pins are designated as outputs by the Action Logic System and are driven low.
4. All unassigned pins are available for use as I/Os.



Package Pin Assignments (continued)

T-46-19-11

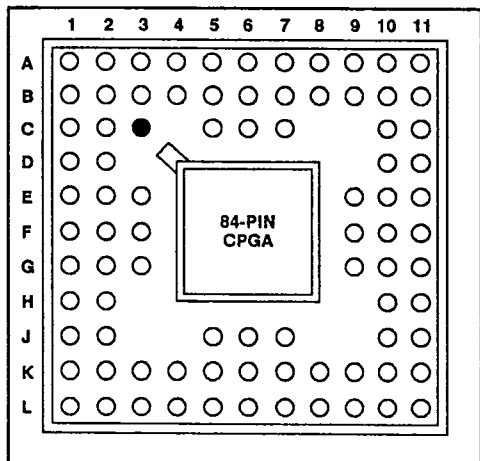

● Orientation Pin (C3)

Signal	A1010-Series Devices	A1020-Series Devices
PRA	A11	A11
PRB	B10	B10
MODE	E11	E11
SDI	B11	B11
DCLK	C10	C10
V <sub>PP</sub>	K2	K2
CLK or I/O	F9	F9
GND	B7, E2, E3, K5, F10, G10	B7, E2, E3, K5, F10, G10
V <sub>CC</sub>	B5, F1, G2, K7, E9, E10	B5, F1, G2, K7, E9, E10
N/C (No Connection)	B1, B2, C1, C2, K1, J2, L1, J10, K10, K11, C11, D10, D11	B2

- Notes:
1. V<sub>PP</sub> must be terminated to V<sub>CC</sub>, except during device programming.
  2. MODE must be terminated to circuit ground, except during device programming or debugging.
  3. Unused I/O pins are designated as outputs by the Action Logic System and are driven low.
  4. All unassigned pins are available for use as I/Os.

Package Mechanical Details  
 J-Leaded Cerquad Chip Carrier

T-46-19-11

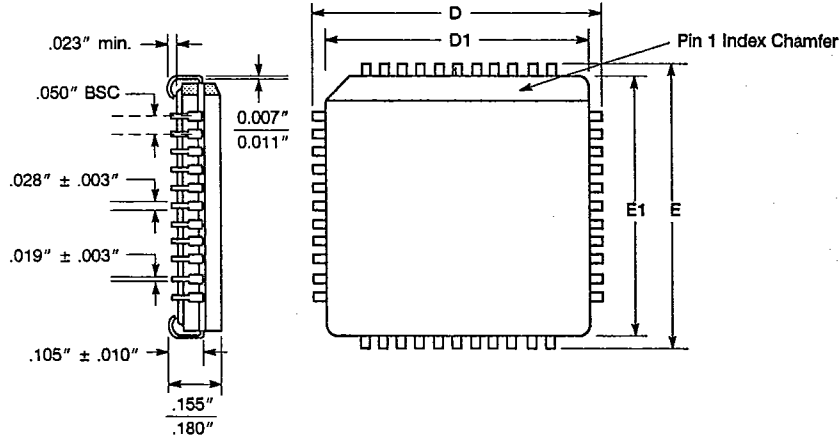

Lead Count	D, E	D1, E1
44	.690" ± .005"	.650" ± .008"
68	.990" ± .005"	.950" ± .008"
84	1.190" ± .005"	1.150" ± .008"

Plastic J-Leaded Chip Carrier

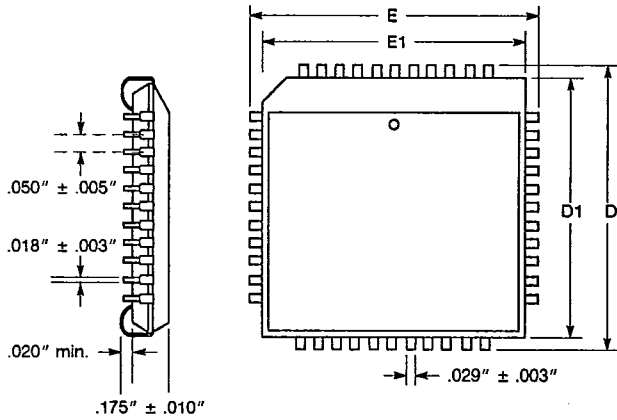

Lead Count	D, E	D1, E1
44	.690" ± .005"	.655" ± .005"
68	.990" ± .005"	.955" ± .005"
84	1.190" ± .005"	1.155" ± .005"

Package Mechanical Details (continued)  
Ceramic Quad Flatpack

T-46-19-11

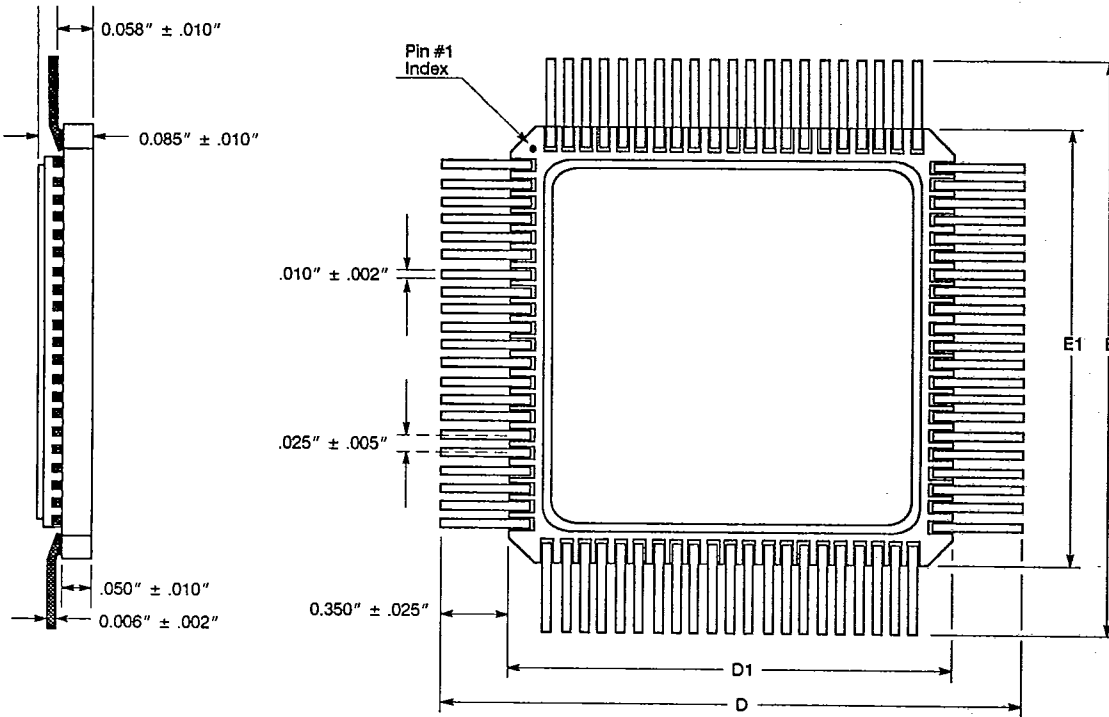

Lead Count	D, E	D1, E1
84	1.350" ± .030"	0.650" ± .010"

T-46-19-11

Package Mechanical Details (continued)  
Ceramic Pin Grid Array

