

## UTC2206

## LINEAR INTEGRATED CIRCUIT

### 2.5W DUAL AUDIO POWER AMP

#### DESCRIPTION

The 2206 is a monolithic integrated circuit consisting of a 2-channel power amplifier. It is suitable for stereo and bridge amplifier application of radio cassette tape recorders.

#### FEATURES

- \*High output power  
Stereo:  $P_o=2.3W(\text{Typ})$  at  $V_{cc}=9V, R_L=4\Omega$ .  
Bridge:  $P_o=4.7W(\text{Typ})$  at  $V_{cc}=9V, R_L=8\Omega$ .
- \*Low switching distortion at high frequency.
- \*Small shock noise at the time of power on/off due to a built-in muting circuit
- \*Good ripple rejection due to a built-in ripple filter.
- \*Good channel separation.
- \*Closed loop voltage gain fixed 45dB(Bridge:51dB) but availability with external resistor added.
- \*Minimum number of external parts required.
- \*Easy to design radiator fin.

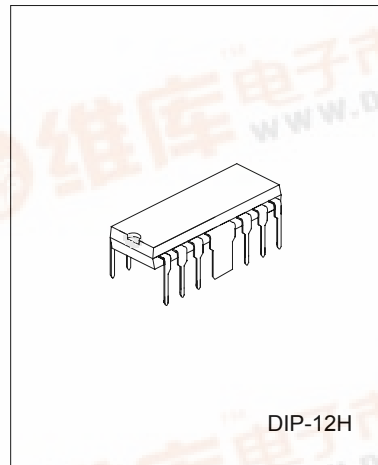

#### BLOCK DIAGRAM

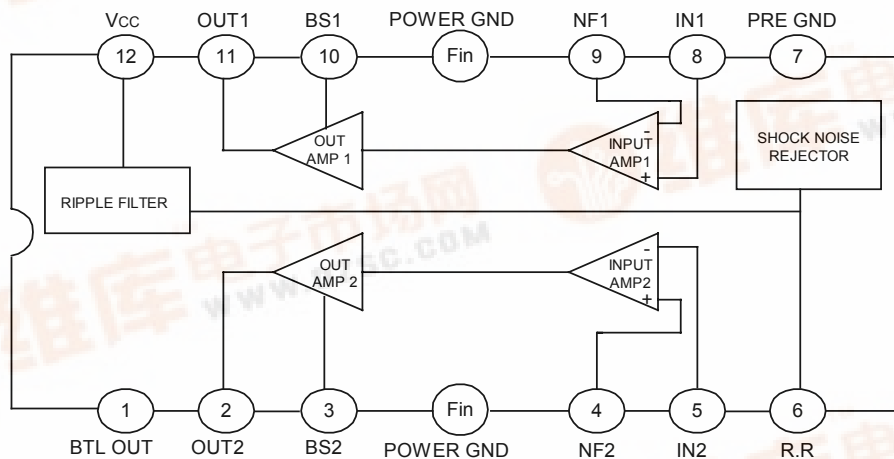

ABSOLUTE MAXIMUM RATINGS (Ta=25°C)

CHARACTERISTICS	SYMBOL	RATING	UNIT
Supply Voltage	V <sub>cc</sub>	15	V
Power Dissipation	P <sub>o</sub>	4 *	W
Operating Temperature	TOPR	-20~+70	°C
Storage Temperature	TSTG	-40~+150	°C

\*Fin is soldering on the PCB

ELECTRICAL CHARACTERISTICS (Ta=25°C, V<sub>cc</sub>=9V, f=1KHz R<sub>G</sub>=600Ω, unless otherwise specified)

CHARACTERISTICS	SYMBOL	TEST CONDITION	MIN	TYP	MAX	UNIT	
Operating Supply Voltage	V <sub>cc</sub>			9	11	V	
Quiescent Circuit Current	I <sub>ccQ</sub>	V <sub>i</sub> =0, Stereo		40	55	mA	
Closed Loop Voltage Gain	GVC	Stereo	V <sub>i</sub> =-45dBm	43	45	47	dB
		Bridge		49	51	53	dB
Output Power	P <sub>o</sub>	Stereo	RL=4Ω, THD=10%	1.7	2.3		W
			RL=8Ω, THD=10%		1.3		W
		Bridge	RL=8Ω, THD=10%		4.7		W
Channel Balance	CB	Stereo		-1	0	1	dB
Total Harmonic Distortion	THD	Stereo	Ro=250mW, RL=4Ω		0.3	1.5	%
		Bridge			0.5		%
Input Resistance	R <sub>i</sub>		21	30		KΩ	
Ripple Rejection Ratio	RR	Stereo, R <sub>G</sub> =0Ω, V <sub>r</sub> =150mW, f=100Hz	40	46		dB	
Output Noise Voltage	V <sub>NO</sub>	Stereo, R <sub>G</sub> =0Ω		0.3	1.0	mW	
		Stereo, R <sub>G</sub> =10KΩ		0.5	2.0	mV	
Cross Talk	CT	Stereo, R <sub>G</sub> =10KΩ, V <sub>o</sub> =0dBm	40	55		dB	

APPLICATION INFORMATION

1. Stereo application

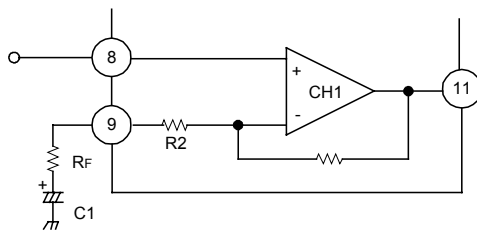

- i) Fixed voltage gain  
(Pin 9 connected to GND directly)

$$G_v = 20 \log \frac{R_1}{R_2} \text{ (dB)}$$

- ii) Variable voltage gain  
(R<sub>f</sub> and C<sub>1</sub> connected with pin 9)

$$G_v = 20 \log \frac{R_1}{R_2 + R_f} \text{ (dB)}$$

2. Bridge application

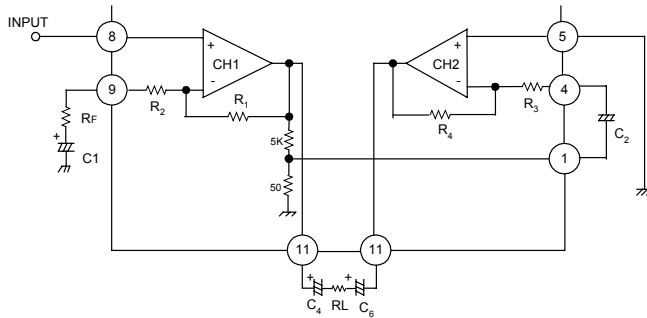

i) Fixed voltage gain (Pin 9 connected to GND directly)

$$G_v = 20 \log \frac{R_1}{R_2} + 6(\text{dB})$$

ii) Variable voltage gain  $R_F$  and  $C_1$  connected with pin 9)

$$G_v = 20 \log \frac{R_1}{R_2 + R_F} + 6(\text{dB})$$

APPLICATION CIRCUIT

1. Stereo Amplifier

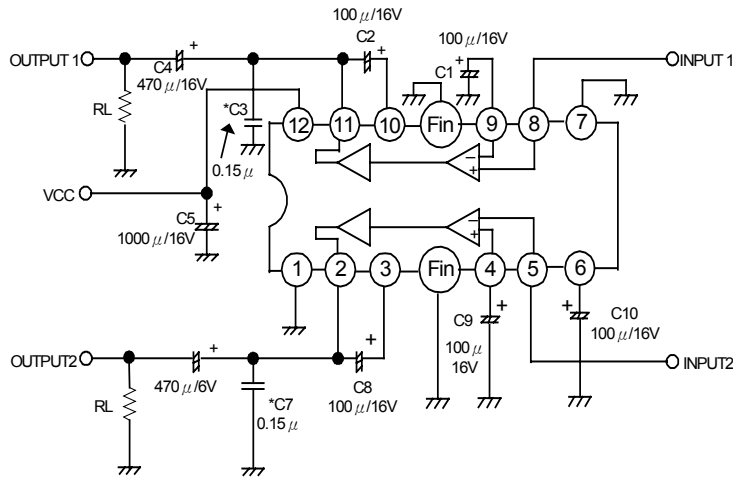

\*polyester film capacitor

2. Bridge Amplifier

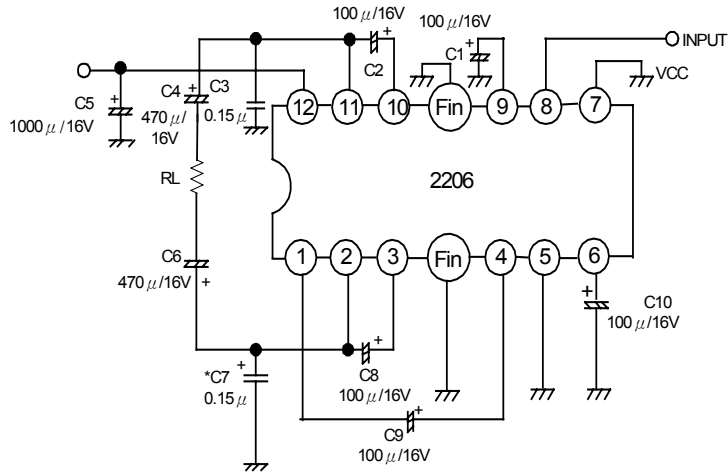

\*polyester film capacitor