

1.5 Watt DC-DC Converters

UM 200 SERIES

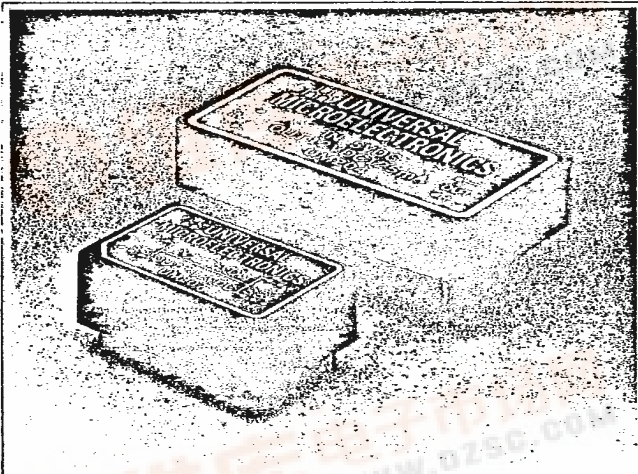

- 50% Efficiency
- Regulated Outputs
- Pi Input Filter
- 500 VDC Isolation
- Low Ripple and Noise
- Short Circuit Protection

SPECIFICATIONS

All Specifications Typical At Nominal Line, Full Load, and 25°C Unless Otherwise Noted.

INPUT SPECIFICATIONS

Input Voltage Range ± 10%
 Input Filter Pi Network

OUTPUT SPECIFICATIONS

Voltage Accuracy ± 4% max.
 Ripple and Noise, 20MHz BW 50mV P-P max.
 Temperature Coefficient ± 0.02%/°C
 Short Circuit Protection Short Term
 Line Regulation ± 0.3%
 Load Regulation ± 0.5%

GENERAL SPECIFICATIONS

Efficiency 50%
 Isolation Voltage 500 VDC min.
 Isolation Capacitance 30pF
 Isolation Resistance 10⁹ ohms
 Switching Frequency 20kHz, min.
 Operating Temperature Range - 25°C to + 71°C
 Storage Temperature Range - 40°C to + 100°C
 Dimensions CASE A 1.25 × 0.8 × 0.4 inches
 (31.8 × 20.3 × 10.2mm)
 CASE B 2 × 1 × 0.4 inches
 (50.8 × 25.4 × 10.2mm)

Case Material

Standard Models Non-Conductive Black Plastic
 Suffix "M" Models Black-Coated Copper with
 Non-Conductive Base

UNIVERSAL MICROELECTRONICS

MODEL NUMBER		INPUT VOLTAGE	OUTPUT VOLTAGE	OUTPUT CURRENT	INPUT CURRENT	
CASE A	CASE B				NO LOAD	FULL LOAD
UM201	UM202	5 VDC	5 VDC	300 mA	100 mA	650 mA
UM203	UM204	5 VDC	12 VDC	125 mA	110 mA	550 mA
UM205	UM206	5 VDC	15 VDC	100 mA	110 mA	550 mA
UM207	UM208	5 VDC	± 12 VDC	± 60 mA	110 mA	550 mA
UM209	UM210	5 VDC	± 15 VDC	± 50 mA	110 mA	560 mA
UM211	UM212	12 VDC	5 VDC	300 mA	40 mA	270 mA
UM213	UM214	12 VDC	12 VDC	125 mA	40 mA	220 mA
UM215	UM216	12 VDC	15 VDC	100 mA	40 mA	220 mA
UM217	UM218	12 VDC	± 12 VDC	± 60 mA	40 mA	220 mA
UM219	UM220	12 VDC	± 15 VDC	± 50 mA	40 mA	220 mA
UM221	UM222	24 VDC	5 VDC	300 mA	20 mA	135 mA
UM223	UM224	24 VDC	12 VDC	125 mA	20 mA	115 mA
UM225	UM226	24 VDC	15 VDC	100 mA	20 mA	115 mA
UM227	UM228	24 VDC	± 12 VDC	± 60 mA	20 mA	115 mA
UM229	UM230	24 VDC	± 15 VDC	± 50 mA	20 mA	115 mA
UM231	UM232	28 VDC	5 VDC	300 mA	20 mA	120 mA
UM233	UM234	28 VDC	12 VDC	125 mA	20 mA	110 mA
UM235	UM236	28 VDC	15 VDC	100 mA	20 mA	100 mA
UM237	UM238	28 VDC	± 12 VDC	± 60 mA	20 mA	100 mA
UM239	UM240	28 VDC	± 15 VDC	± 50 mA	20 mA	100 mA
UM241	UM242	48 VDC	5 VDC	300 mA	15 mA	70 mA
UM243	UM244	48 VDC	12 VDC	125 mA	15 mA	60 mA
UM245	UM246	48 VDC	15 VDC	100 mA	15 mA	60 mA
UM247	UM248	48 VDC	± 12 VDC	± 60 mA	15 mA	60 mA
UM249	UM250	48 VDC	± 15 VDC	± 50 mA	15 mA	60 mA

CASE A

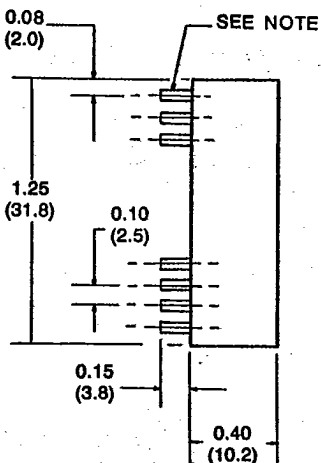
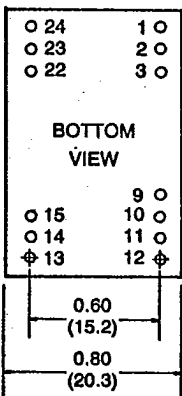

CASE B

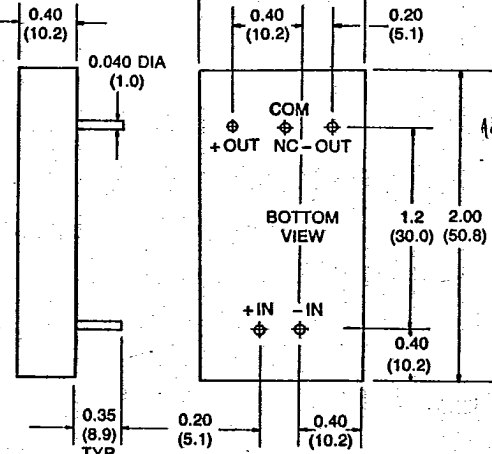

Pin Connections		
Pin	Single Output	Dual Output
1	+V Input	+V Input
2	NC*	-V Output
3	NC*	Common
10	-V Output	Common
11	+V Output	+V Output
12	-V Input	-V Input
13	-V Input	-V Input
14	+V Output	+V Output
15	-V Output	Common
22	NC*	Common
23	NC*	-V Output
24	+V Input	+V Input

ALL DIMENSIONS IN INCHES (MM)
 NOTE: PIN SIZE IS .020 INCH (0.5mm) DIA.
 OR .020 x .014 INCH.

* NC (NO CONNECTION) ON SINGLE OUTPUT MODELS