



UC494A/AC
UC495A/AC

Advanced Regulating Pulse Width Modulators

FEATURES

- Dual Uncommitted 40V, 200mA Output Transistors
- 1% Accurate 5V Reference
- Dual Error Amplifiers
- Wide Range, Variable Deadtime
- Single-ended or Push-pull Operation
- Under-voltage Lockout With Hysteresis
- Double Pulse Protection
- Master or Slave Oscillator Operation
- UC495A: Internal 39V Zener Diode
- UC495A: Buffered Steering Control

DESCRIPTION

This entire series of PWM modulators each provide a complete pulse width modulation system in a single monolithic integrated circuit. These devices include a 5V reference accurate to $\pm 1\%$, two independent amplifiers usable for both voltage and current sensing, an externally synchronizable oscillator with its linear ramp generator, and two uncommitted transistor output switches. These two outputs may be operated either in parallel for single-ended operation or alternating for push-pull applications with an externally controlled dead-band. These units are internally protected against double-pulsing of a single output or from extraneous output signals when the input supply voltage is below minimum.

The UC495A contains an on-chip 39V zener diode for high-voltage applications where V_{CC} would be greater than 40V, and a buffered output steering control that overrides the internal control of the pulse steering flip-flop.

The UC494A is packaged in a 16-pin DIP, while the UC495A is packaged in an 18 pin DIP. The UC494A, UC495A are specified for operation over the full military temperature range of -55°C to $+125^{\circ}\text{C}$, while the UC494AC, UC495AC are designed for industrial applications from 0°C to $+70^{\circ}\text{C}$.

BLOCK DIAGRAM

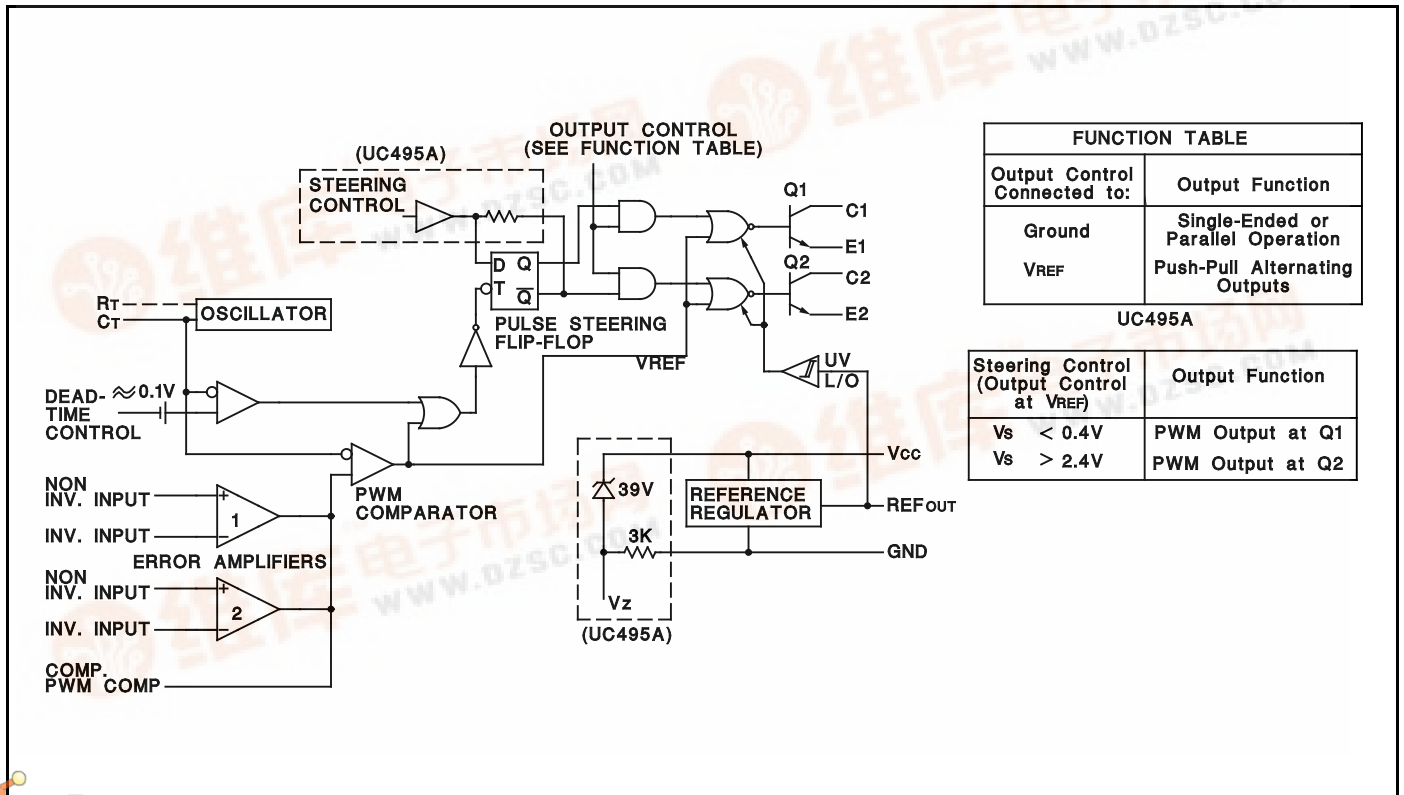

FUNCTION TABLE	
Output Control Connected to:	Output Function
Ground	Single-Ended or Parallel Operation
V_{REF}	Push-Pull Alternating Outputs

UC495A

Steering Control (Output Control at V_{REF})	Output Function
$V_s < 0.4V$	PWM Output at Q1
$V_s > 2.4V$	PWM Output at Q2



UC494A/AC
UC495A/AC

ABSOLUTE MAXIMUM RATINGS (Note 1, 2, 3)

Supply Voltage, Vcc (Note 2)	45V
Amplifier Input Voltages	Vcc + 0.3V
Collector Output Voltage	41V
Collector Output Current	250mA
Continuous Total Dissipation	1000mW
@ (or below) 25°C free air temperature range (Note 3)	
Storage Temperature Range	-65° to +150°C
Lead Temperature 1/16" (1.6mm) from case for 60 seconds, J Package	300°C
Lead Temperature 1/16" (1.6mm) from case for 10 seconds, N Package	260°C

Note 1: Over operating free air temperature range unless otherwise noted.

Note 2: All voltage values are with respect to network ground terminal 3.

Note 3: Consult Packaging Section of Databook regarding thermal specifications and limitations of packages.

RECOMMENDED OPERATING CONDITIONS

Supply Voltage Vcc	7V to 40V
Error Amplifier Input Voltages	-0.3V to Vcc-2V
Collector Output Voltage	40V
Collector Output Current (each transistor)	200mA
Current into Feedback Terminal	0.3mA
Timing Capacitor, CT	0.47nF to 10,000nF
Timing Resistor, RT	1.8kΩ to 500kΩ
Oscillator Frequency	1kHz to 300kHz
Operating Free Air Temperature	
UC494A, UC495A	-55°C to +125°C
UC494AC, UC495AC	0°C to +70°C

CONNECTION DIAGRAMS

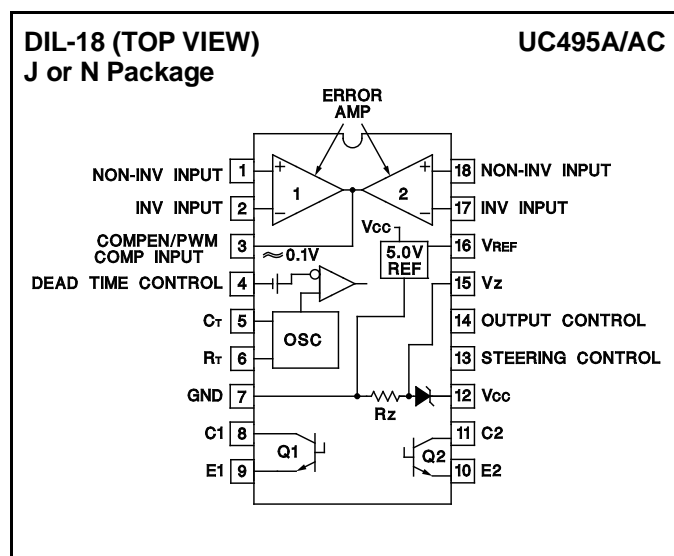
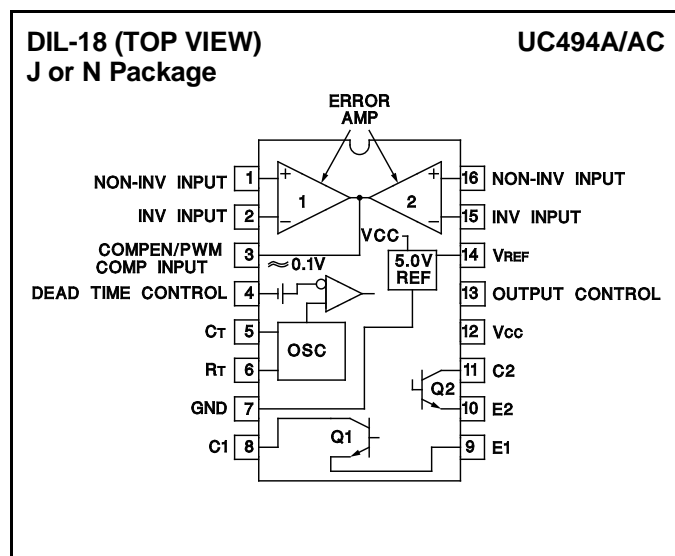

ELECTRICAL CHARACTERISTICS: Unless otherwise stated, over recommended operating free-air temperature range, Vcc = 15V, f = 10kHz, TA = TJ.

PARAMETER	TEST CONDITIONS	MIN	TYP	MAX	UNITS
Reference Section					
Output Voltage VREF	Io = 1mA, TA = 25°C	4.95	5	5.05	V
Input Regulation	Vcc = 7V to 40V		2	25	mV
Output Regulation	Io = 1mA to 10mA		1	15	mV
Output Voltage Over Temperature	ΔTA = Min. to Max.	4.90		5.10	V
Short Circuit Output Current	VREF = 0, TA = 25°C (Note 1)	10	35	50	mA
Oscillator Section					
Frequency (Note 2)	CT = 0.01μF, RT = 12kΩ		10		kHz
Standard Deviation Of Frequency (Note 3)	All Values of Vcc, CT, RT, TA Constant		10		%
Frequency Change With Voltage	Vcc = 7V to 40V, TA = 25°C		0.1		%
Frequency Change With Temperature	CT = 0.01μF, RT = 12kΩ, ΔTA = Min. to Max.			2	%
Deadtime Control Section (Output Control Connected to VREF)					
Input Bias Current (Pin 4)	V(PIN 4) = 0V to 5.25V		-2	-10	μA
Maximum Duty-Cycle (Each Output)	V(PIN 4) = 0V	45			%

UC494A/AC
UC495A/AC

ELECTRICAL CHARACTERISTICS: Unless otherwise stated, over recommended operating free-air temperature range, $V_{CC} = 15V$, $f = 10kHz$, $T_A = T_J$.

PARAMETER	TEST CONDITION	MIN	TYP	MAX	UNITS	
Deadtime Control Section (cont.) (Output Control Connected to V_{REF})						
Input Threshold Voltage (Pin 4)	Zero Duty-Cycle		3	3.3	V	
	Maximum Duty-Cycle	0			V	
Amplifier Section						
Input Offset Voltage	V_O (PIN 3) = 2.5V		2	10	mV	
Input Offset Current	V_O (PIN 3) = 2.5V		25	250	nA	
Input Bias Current	V_O (PIN 3) = 2.5V		-0.2	-1	μA	
Common-Mode Input Voltage Range	$V_{CC} = 7V$ to 40V	.03 to $V_{CC} - 2$			V	
Open Loop Voltage Gain	$\Delta V_O = 3V$, $V_O = 0.5V$ to 3.5 V	70	95		dB	
Unity Gain Bandwidth			800		kHz	
Common-Mode Rejection Ratio	$V_{CC} = 40V$, $T_A = 25^\circ C$	65	80		dB	
Output Sink Current (Pin 3)	$V_{ID} = -15mV$ to $-5V$, $V_{(PIN 3)} = 0.7V$	0.3	0.7		mA	
Output Source Current (Pin 3)	$V_{ID} = 15mV$ to 5V, $V_{(PIN 3)} = 3.5V$	-2			mA	
Output Section						
Collector Off-State Current	$V_{CE} = 40V$, $V_{CC} = 40V$		2	100	μA	
Emitter Off-State Current	$V_{CC} = V_C = 40V$, $V_E = 0$			-100	μA	
Collector - Emitter Saturation Voltage	Common-Emitter	$V_E = 0$, $I_C = 200mA$	1.1	1.3	V	
	Emitter-Follower	$V_C = 15V$, $I_E = -200mA$	1.5	2.5	V	
Output Control Input Current	$V_I = V_{REF}$			3.5	mA	
PWM Comparator Section						
Input Threshold Voltage (Pin 3)	Zero Duty-Cycle		4	4.5	V	
Input Sink Current (Pin 3)	$V_{(PIN 3)} = 0.7V$	0.3	0.7		mA	
Steering Control (UC495A, See Function Table)						
Input Current	$V_{(PIN 13)} = 0.4V$, Q1 ACTIVE			-200	μA	
	$V_{(PIN 13)} = 2.4V$, Q2 ACTIVE			300	μA	
Deadband			500		mV	
Zener Diode Circuit (UC495A)						
Breakdown Voltage	$V_{CC} = 45V$, $I_Z = 2mA$	36	39	45	V	
Sink Current	$V_{(PIN 15)} = 1V$	0.2	0.3	0.6	mA	
Total Device						
Standby Supply Current	Pin 6 at V_{REF} , All other inputs and outputs open	$V_{CC} = 15V$		6	10	mA
		$V_{CC} = 40V$		9	15	mA
Under Voltage Lockout		3.5		6.5	V	
Hysteresis			300		mV	
Switching Characteristics ($T_A = 25^\circ C$)						
Output Voltage Rise Time	Common-Emitter Configuration		100	200	ns	
Output Voltage Fall Time	$R_L = 68\Omega$, $C_L = 15pF$		25	100	ns	
Output Voltage Rise Time	Emitter-Follower Configuration		100	200	ns	
Output Voltage Fall Time	$R_L = 68\Omega$, $C_L = 15pF$		40	100	ns	

Note 1: Duration of the short circuit should not exceed one second.

Note 2: Frequency for other values of C_T and R_T is approximately $f = \frac{1.1}{RTCT}$

Note 3: Standard deviation is a measure of the statistical distribution about the mean as derived from the formula:

$$\sigma = \sqrt{\frac{\sum_{n=1}^n (X_n - \bar{X})^2}{n-1}}$$

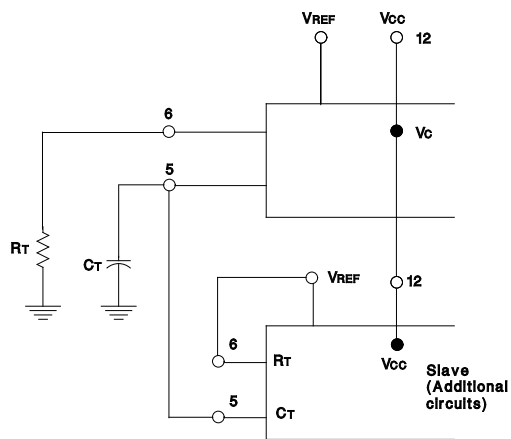

Figure 1. Slaving Two or More Control Circuits

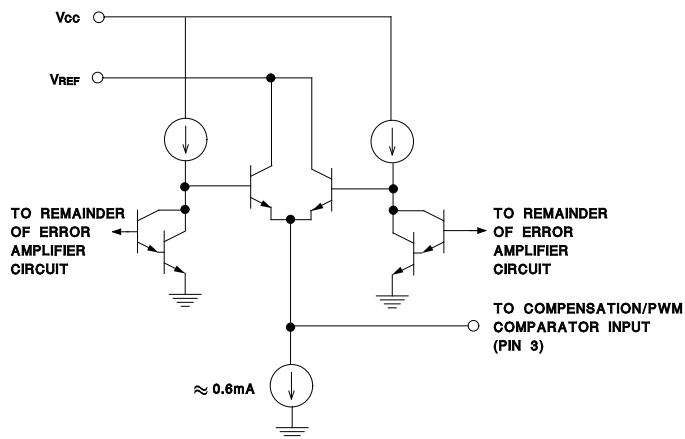
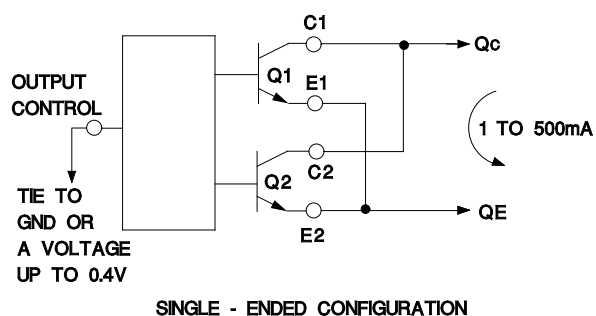
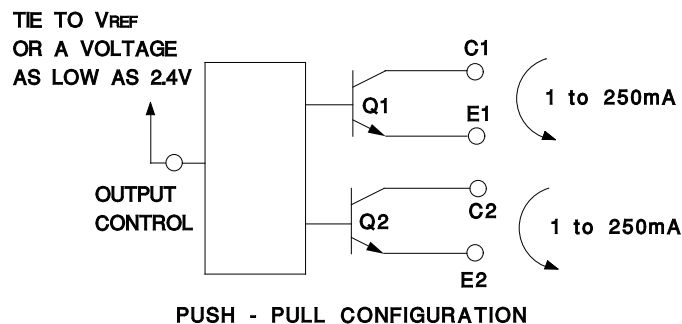

Figure 2. Output Circuit of Error Amplifiers



SINGLE - ENDED CONFIGURATION



PUSH - PULL CONFIGURATION

Figure 3. Output Connections for Single-Ended and Push-Pull Configurations

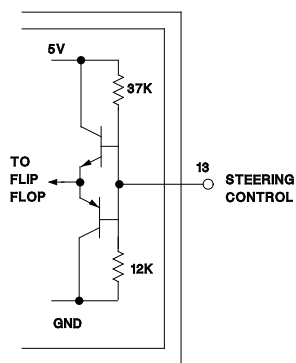

Figure 4. Internal Buffer with Deadband for Steering Control on UC495A

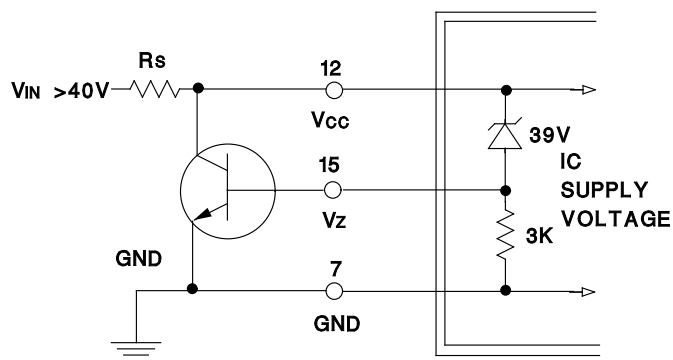

Figure 5. Operation with VIN > 40V Using Internal Zener

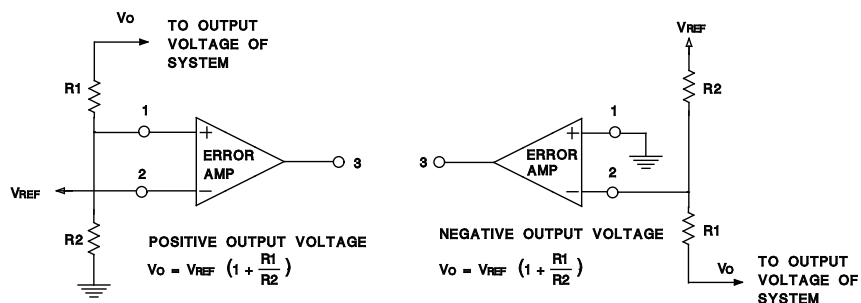

Figure 6. Error Amplifier Sensing Techniques

IMPORTANT NOTICE

Texas Instruments and its subsidiaries (TI) reserve the right to make changes to their products or to discontinue any product or service without notice, and advise customers to obtain the latest version of relevant information to verify, before placing orders, that information being relied on is current and complete. All products are sold subject to the terms and conditions of sale supplied at the time of order acknowledgement, including those pertaining to warranty, patent infringement, and limitation of liability.

TI warrants performance of its semiconductor products to the specifications applicable at the time of sale in accordance with TI's standard warranty. Testing and other quality control techniques are utilized to the extent TI deems necessary to support this warranty. Specific testing of all parameters of each device is not necessarily performed, except those mandated by government requirements.

CERTAIN APPLICATIONS USING SEMICONDUCTOR PRODUCTS MAY INVOLVE POTENTIAL RISKS OF DEATH, PERSONAL INJURY, OR SEVERE PROPERTY OR ENVIRONMENTAL DAMAGE ("CRITICAL APPLICATIONS"). TI SEMICONDUCTOR PRODUCTS ARE NOT DESIGNED, AUTHORIZED, OR WARRANTED TO BE SUITABLE FOR USE IN LIFE-SUPPORT DEVICES OR SYSTEMS OR OTHER CRITICAL APPLICATIONS. INCLUSION OF TI PRODUCTS IN SUCH APPLICATIONS IS UNDERSTOOD TO BE FULLY AT THE CUSTOMER'S RISK.

In order to minimize risks associated with the customer's applications, adequate design and operating safeguards must be provided by the customer to minimize inherent or procedural hazards.

TI assumes no liability for applications assistance or customer product design. TI does not warrant or represent that any license, either express or implied, is granted under any patent right, copyright, mask work right, or other intellectual property right of TI covering or relating to any combination, machine, or process in which such semiconductor products or services might be or are used. TI's publication of information regarding any third party's products or services does not constitute TI's approval, warranty or endorsement thereof.