

2.9 GHz PLL for SAT TV Receiver with Universal Bus

Features

- 2.9 GHz divide-by-16 prescaler integrated
- 3 selectable reference divider ratios:
÷256 / ÷512 / ÷1024
- Universal bus:
I²C-bus or 3-wire-bus
I²C-bus software compatible to U6204B
3-wire-bus software compatible to U6358B (19 bit)
- I²C-bus mode:
5 switching outputs (open collector)
4 addresses selectable at pin 10 for multituner application
- 3-wire-bus mode:
4 switching outputs (open collector)
Locksignal output (open collector)
- Low power consumption (typical 5 V / 23 mA)
- Electrostatic protection according to MIL-STD 883

Package: SO16 small

Block Diagram

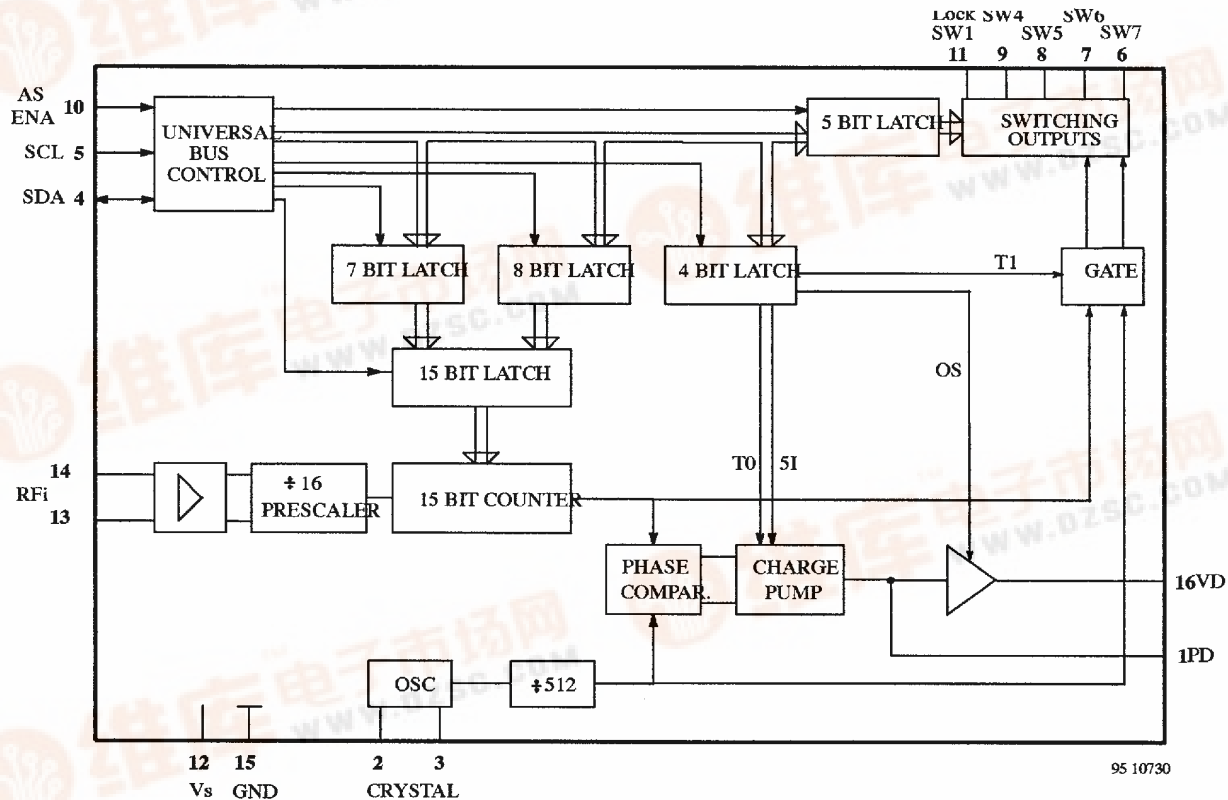

Figure 1. Block diagram

U6223B-AFP

Pin Description

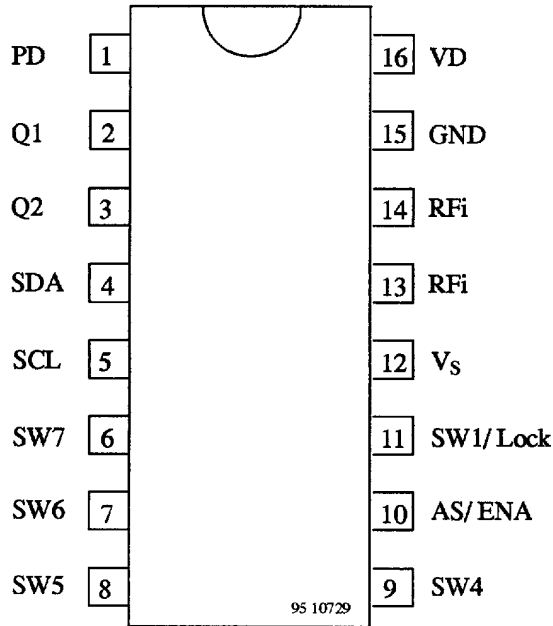

Figure 2.

Pin	Symbol	Function
1	PD	Charge pump output
2	Q1	Crystal
3	Q2	Crystal
4	SDA	Data in/output
5	SCL	Clock input
6	SW7	Switching output open collector
7	SW6	Switching output open collector
8	SW5	Switching output open collector
9	SW4	Switching output open collector
10	AS / ENA	Address select / enable input
11	SW1 / Lock	Switching / lock output open collector
12	Vs	Supply voltage
13	RFi	RF input
14	RFi	RF input
15	GND	Ground
16	VD	Active filter output

Absolute Maximum Ratings

All voltages are referred to GND (Pin 15)

Parameters	Symbol	Value	Unit
Supply voltage Pin 12	Vs	-0.3 to 6	V
RF input voltage Pin 13, 14	RFi	-0.3 to Vs+0.3	V
Switching output current open collectors Pin 6 - 9, 11	SW 1, 4-7	-1 to 15	mA
Total current of switching outputs Open collectors Pin 6 - 9, 11	SW 1, 4-7	50	mA
Switching output voltage Pin 6 - 9, 11	SW 1, 4-7	-0.3 to 14	V
in off state:		-0.3 to 6	V
in on state:		-0.3 to 6	V
Bus input/output voltage Pin 4	VSDA	-0.3 to 6	V
Pin 5	VSCL	-0.3 to 6	V
SDA output current open collector Pin 4	ISDA	-1 to 5	mA
Address select voltage Pin 10	VAS / ENA	-0.3 to Vs+0.3	V
Charge pump output voltage Pin 1	PD	-0.3 to Vs+0.3	V
Active filter output voltage Pin 16	VD	-0.3 to Vs+0.3	V
Crystal oscillator voltage Pin 2	Q1	-0.3 to Vs+0.3	V
Reference divider switch voltage, Pin 3	RDS	-0.3 to Vs + 0.3	V
Junction temperature	T _{jmax}	-40 to 125	°C
Storage temperature	T _{stg}	-40 to 125	°C

Operating Range

All voltages are referred to GND (Pin 15)

Parameters	Symbol	Min.	Typ.	Max.	Unit
Supply voltage Pin 12	V _S	4.5	5.5		V
Ambient temperature	T _{amb}	0	70		°C
Input frequency Pin 13, 14	R _{Fi}	250	2900		MHz
Progr. divider	S _F	256	32767		

Thermal Resistance

Parameters	Symbol	Value	Unit
Junction ambient	R _{thJA}	110	K/W

Electrical Characteristics

Test conditions: V_S = 5 V, T_{amb} = 25°C, unless otherwise specified

Parameters	Test Conditions / Pins	Symbol	Min.	Typ.	Max.	Unit
Supply current	SW 1, 4, 5, 6, 7 = 0 Pin 12	I _S	18	23	28	mA
Input sensitivity						
Input frequency	f _i = 250 MHz, Pin 13 f _i = 750-2900 MHz, Pin 13	V _i ¹⁾ V _i ¹⁾	100 20		300 300	mVrms mVrms
Crystal oscillator						
Recommended crystal series resistance			10		200	Ω
Crystal oscillator drive level	Pin 2			50		mVrms
Crystal oscillator source impedance	Nominal spread ±15% Pin 2			-650		Ω
External reference input frequency	AC coupled sinewave Pin 2		2		8	MHz
External reference input amplitude	AC coupled sinewave Pin 2		70		200	mVrms
Switching outputs (SW4-7, Pin 6-9), lock output, open collector(SW1/lock, Pin 11)						
Leakage current	V _H = 13.5 V	I _L			10	μA
Saturation voltage	I _L = 10 mA	V _{SL} ²⁾			0.5	V
Charge pump output (PD)						
Charge pump current 'H'	5I = H, VPD = 2 V Pin 1	IPDH		±180		μA
Charge pump current 'L'	5I = L, VPD = 2 V Pin 1	IPDL		±50		μA
Charge pump leakage current	T ₀ = 0, VPD = 2 V Pin 1	IPDTRI		±5		nA
Charge pump amplifier gain	Pin 1, 16			6400		
Bus inputs (SDA, SCL)						
Input voltage	Pin 4, 5 Pin 4, 5	V _i 'H' V _i 'L'	3		5.5 1.5	V V

U6223B-AFP

Parameters	Test Conditions / Pins	Symbol	Min.	Typ.	Max.	Unit
Input current	VSCL 'H' = Vs Pin 4, 5	li 'H'			10	µA
	VSCL 'L' = 0 V Pin 4, 5	li 'L'	-10			µA
Leakage current	Vs = 0 V Pin 4, 5	IL			10	µA
Output voltage SDA (open collector)	ISDA 'L' = 2 mA, Pin 4	VSDA 'L'			0.4	V
Address selection / Enable input (SA, ENA)						
Input current	VAS 'H' = Vs Pin 10	liAS 'H'			10	µA
	VAS 'L' = 0 Pin 10	liAS 'L'	-100			µA

- 1) RMS-voltage calculated from the measured available power on 50 Ω
- 2) Tested with one switch active, the collector voltage may not exceed 6 V

Description

The U6223B is a single chip PLL designed for SAT receiver systems. It consists of a divide-by-16 prescaler (up to 2.9 GHz) with an integrated preamplifier, a 15 bit programmable divider, a crystal oscillator with a reference divider with three selectable divider ratios (÷ 256 / ÷ 512 / ÷ 1024), a phase/frequency detector together with a charge-pump, which is driving the tuning amplifier. Only one external transistor is required for varactor line driving. The device can be controlled via I²C-bus format or the 3-wire-bus format. It detects automatically which bus format is received, therefore there is no need for a bus selection pin. In I²C-bus mode the device has four programmable addresses, programmed by applying a specific input voltage to the address select input, enabling the use of up to four synthesizers in a system. The same pin serves in 3-wire-bus mode as the enable signal input. Five open collector outputs for switching functions are included, which are capable of sinking at least 10 mA. One of these open collector outputs serves as Locksignal output in the 3-wire-bus mode.

Functional Description

The U6223B is programmed via 2-wire I²C bus or 3-wire bus depending on the received data format. The three bus inputs pins 4, 5 and 10 are used as SDA, SCL and address select inputs in I²C-bus mode and as data, clock and enable inputs in 3-wire bus mode. The data includes the scaling factor SF (15 bit) and switching output information. In I²C-bus mode there are some additional functions for testing of the device included.

Oscillator Frequency Calculation

$$f_{vco} = 16 * SPF * f_{refosc} / 512$$

f_{vco}: Locked frequency of voltage controlled oscillator

SPF: Scaling factor of programmable

SRF: 15-bit-divider
Scaling factor of reference divider:
÷ 256 / ÷ 512 / ÷ 1024

f_{refosc}: Reference oscillator frequency:
3.2 / 4 MHz crystal or external
reference frequency

The input amplifier together with a divide-by-16 prescaler gives an excellent sensitivity (see 'Typical Prescaler Input Sensitivity'). The input impedance is shown in the diagram 'Typical Input Impedance'. When a new divider ratio according to the requested f_{vco} is entered, the phase detector and charge pump together with the tuning amplifier adjusts the control voltage of the VCO until the output signals of the programmable divider and the reference divider are in frequency and phase locked. The reference frequency may be provided by an external source capacitively coupled into Pin 2, or by using an on-board crystal with an 18 pF capacitor in series. The crystal operates in the series resonance mode. The reference divider division ratio is selectable to ÷ 256 / ÷ 512 / ÷ 1024. Therefore with a 4 MHz crystal and nominal division ratio of 512 of the reference divider the comparison frequency is 7.8125 kHz, which gives 125 kHz steps for the VCO, or with a 3.2 MHz crystal respectively 6.25 kHz comparison frequency and 100 kHz VCO step size. In addition there are switching outputs available for bandswitching and other purposes.

Application

The U6223B is function and pin equivalent to the U6225B apart from the switchable reference divider. A typical application is shown on page ?. All input / output interface circuits are shown on page ?. Some special features which are related to test- and alignment procedures for tuner production are explained together within the following bus mode description.

I²C-Bus Description

When the U6223B is controlled via 2-wire I²C-bus format, then data and clock signals are fed into the SDA and SCL lines respectively. The table 'I²C-BUS DATA FORMAT' describes the format of the data and shows how to select the device address by applying a voltage at pin 10. When the correct address byte is received, the SDA line is pulled low by the device during the acknowledge period, and then also during the acknowledge periods, when additional data bytes are programmed. After the address transmission (first byte), data bytes can be sent to the device. There are four data bytes requested to fully program the device. The table 'I²C-BUS PULSE DIAGRAM' shows some possible data transfer examples.

Programmable divider bytes PDB1 and PDB2 are stored in a 15 bit latch and are controlling the division ratio of the 15 bit programmable divider. The control Byte CB1 allows to control the following special functions:

- 5I-bit switches between low and high charge pump current
- T1-bit enables divider test mode when it is set to logic 1
- T0-bit allows to disable the charge pump when it is set to logic 1
- RD1 and RD2-bit allow to select the reference divider factor
- OS-bit disable the charge pump drive amplifier output when it is set to logic 1.

Only in I²C bus mode the charge pump current can be controlled. In 3-wire-bus mode there is always the high charge pump current active. The OS-bit function disables the complete PLL function. This allows the tuner alignment by supplying the tuning voltage directly through the 30 V supply voltage of the tuner.

The control byte CB2 programs the switching outputs SW 1, 4, 5, 6, 7; a logic 0 for high impedance output (off) and a logic 1 for low impedance output (on).

Description	I ² C-Bus Data Format								
	MSB					LSB			
Address byte	1	1	0	0	0	AS1	AS2	0	A
Progr. divider byte 1	0	n14	n13	n12	n11	n10	n9	n8	A
Progr. divider byte 2	n7	n6	n5	n4	n3	n2	n1	n0	A
Control byte 1	1	5I	T1	T0	X	RD2	RD1	OS	A
Control byte 2	SW7	SW6	SW5	SW4	X	X	SW1	X	A

A = Acknowledge; X = not used; Unused bits of controlbyte 2 should be 0 for lowest power consumption

n0 ... n14	Scaling factor (SF)	SF = 16384*n14+8192*n13+ ... +2*n1 + n0
T0, T1	Testmode selection	T1 = 1: divider test mode on T1 = 0: divider test mode off T0 = 1: charge pump disable T0 = 0: charge pump enable
SW1, 4, 5, 6, 7	Switching outputs	SW1, SW4, SW5, SW6, SW7 = 1: open collector active
5I	Charge pump current switch	5I = 1: high current 5I = 0: low current
OS	Output switch	OS = 1: varicap driver disable OS = 0: varicap drive enable
RD1, RD2	Reference divider selection	

RD2	RD1	Reference Divider Ratio
0	0	1024
0	1	off
1	0	256
1	1	512

U6223B-AFP

I²C-Bus Pulse Diagram

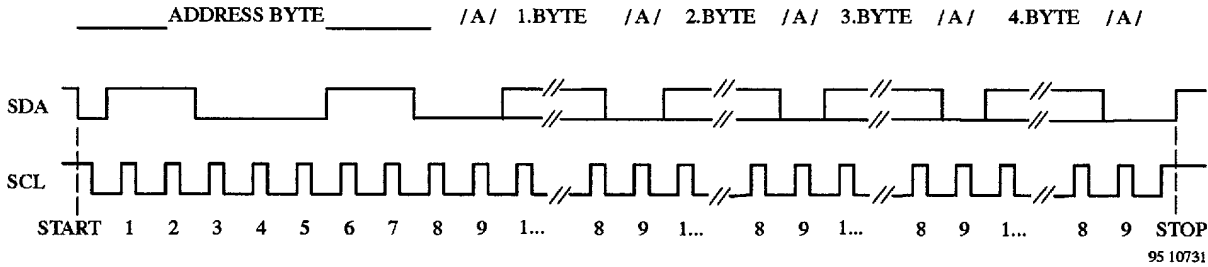

Figure 3.

Data transfer examples

START ADR PDB1 PDB2 CB1 CB2 STOP
 START ADR CB1 CB2 PDB1 PDB2 STOP
 START ADR PDB1 PDB2 CB1 STOP
 START ADR CB1 CB2 PDB1 STOP
 START ADR PDB1 PDB2 STOP
 START ADR CB1 CB2 STOP
 START ADR CB1 STOP

Description

START = Start condition
 ADR = Address byte
 PDB1 = Progr. divider byte 1
 PDB2 = Progr. divider byte 2
 CB1 = Control byte 1
 CB2 = Control byte 2
 STOP = Stop condition

I²C-Bus Timing

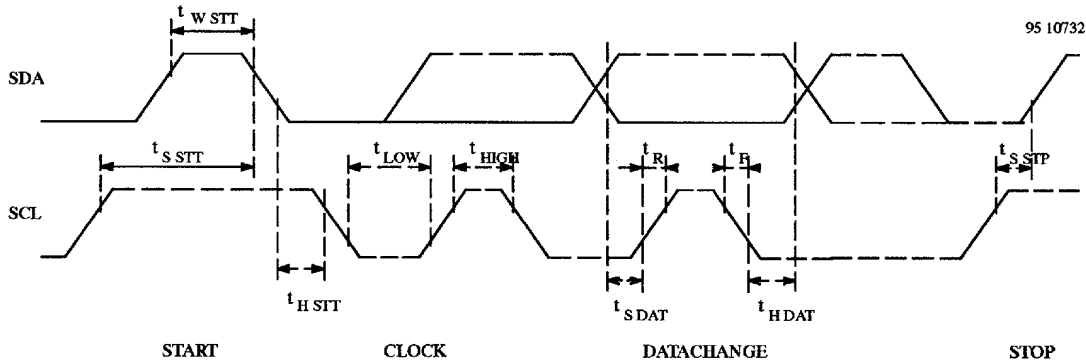

Figure 4.

Parameters	Symbol	Min.	Typ.	Max.
Rise time SDA, SCL	t _R		15	μs
Fall time SDA, SCL	t _F		15	μs
Clock frequency SCL	f _{SCL}	0	100	kHz
Clock 'H' pulse	t _{HIGH}	4		μs
Clock 'L' pulse	t _{LOW}	4		μs
Hold time start	t _{H STT}	4		μs
Waiting time start	t _{W STT}	4		μs
Set-up time start	t _{S STT}	4		μs
Set-up time stop	t _{S STP}	4		μs
Set-up time data	t _{S DAT}	0.3		μs
Hold time data	t _{H DAT}	0		μs

3-Wire-Bus Description

When the U 6225 B-B is controlled via 3-wire bus format, then DATA, CLOCK and ENABLE signals are fed into the SDA, SCL and AS/ENA lines respectively. The diagram '3-WIRE-BUS PULSE DIAGRAM' shows the data format. The data consist of a single word, which contains the programmable divider and switch information. Only during the enable high period the data is clocked into the internal data shift register on the negative clock transition. During enable low periods the clock input is disabled. New data words are only accepted by the internal data latches from the shift register on a negative transition of the enable signal when during the high period of the enable exactly nineteen clock pulses were send. The data sequence and the timing is described in the following diagrams.

In 3-wire-bus mode pin 11 becomes automatically the Locksignal output. An improved lock detect circuit generates a flag when the loop has attained lock. 'In lock' is indicated by a low impedance state (on) of the open collector output.

In 3-wire-bus mode there is always the high charge pump current active. Only in I²C-bus mode the charge pump current can be controlled.

The complete PLL function can be disabled by programming a normally not used division ratio of zero. This allows the tuner alignment by supplying the tuning voltage directly through the 30 V supply voltage of the tuner.

3-Wire-Bus Pulse Diagram

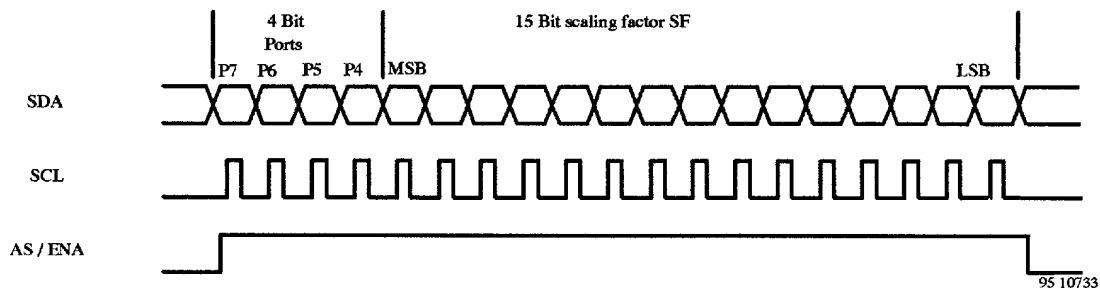

Figure 5.

3-Wire-Bus Timing

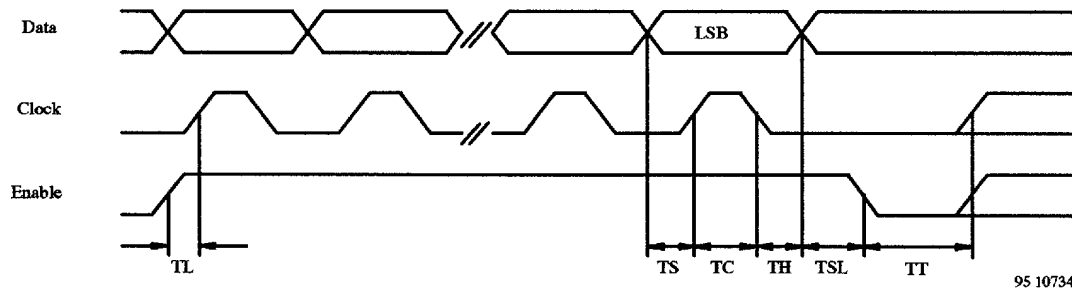

Figure 6.

Parameters	Symbol	Min	Typ.	Unit
Set up time	TS	2		µs
Enable hold time	TSL	2		µs
Clock width	TC	2		µs
Enable set up time	TL	10		µs
Enable between two transmissions	TT	10		µs
Data hold time	TH	2		µs

Input/Output Interface Circuits

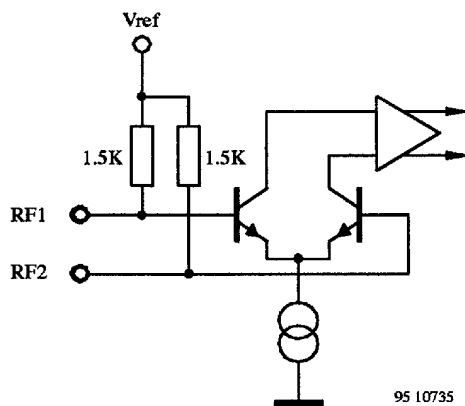

Figure 7. RF input

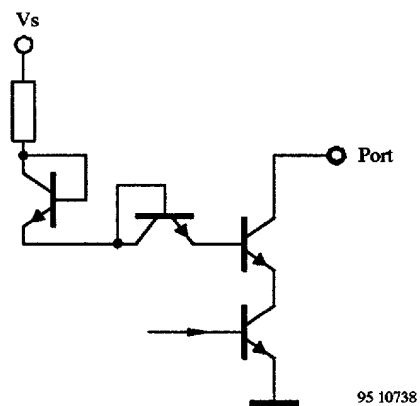

Figure 10. Ports

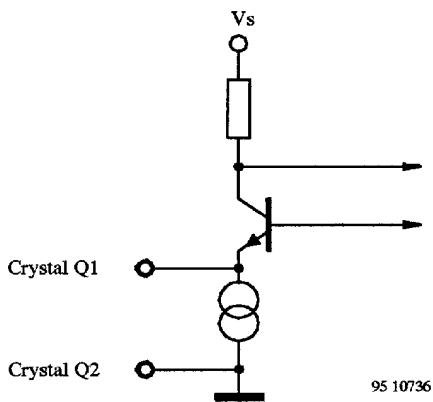

Figure 8. Reference oscillator

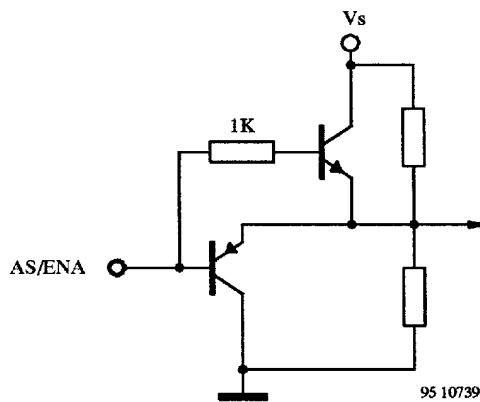

Figure 11. Address select/ Enable input

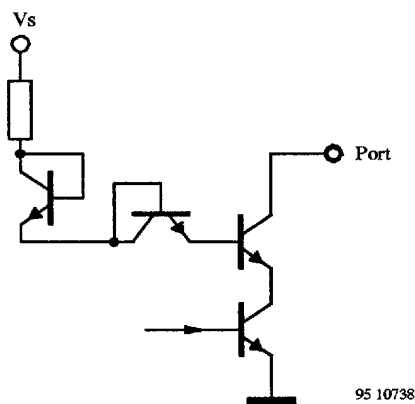

Figure 9. SCL SDA input

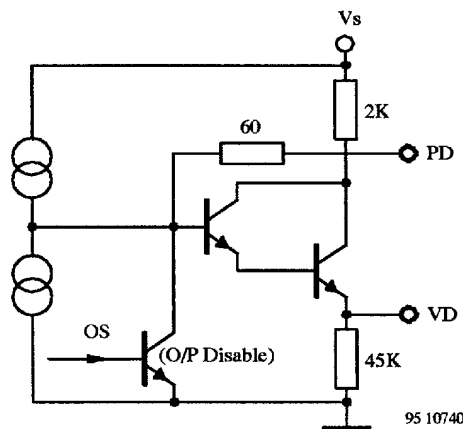

Figure 12. Loop amplifier

Typical Prescaler Input Sensitivity

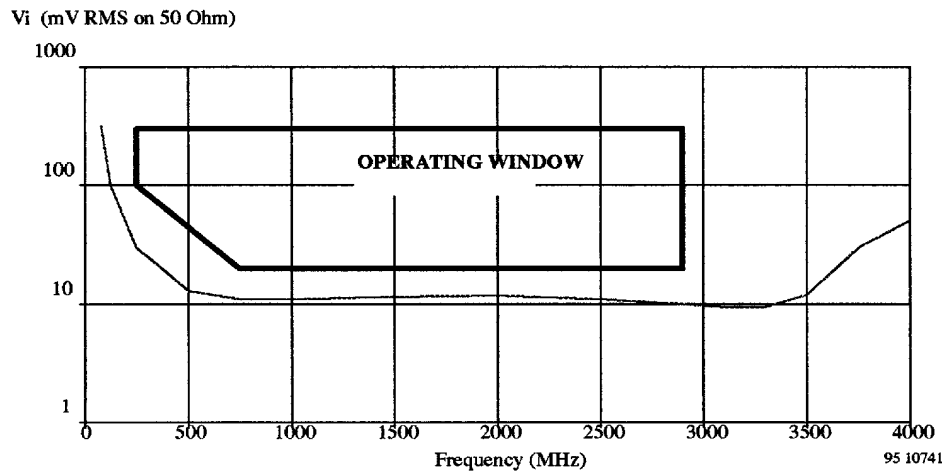

Figure 13.

Typical Input Impedance

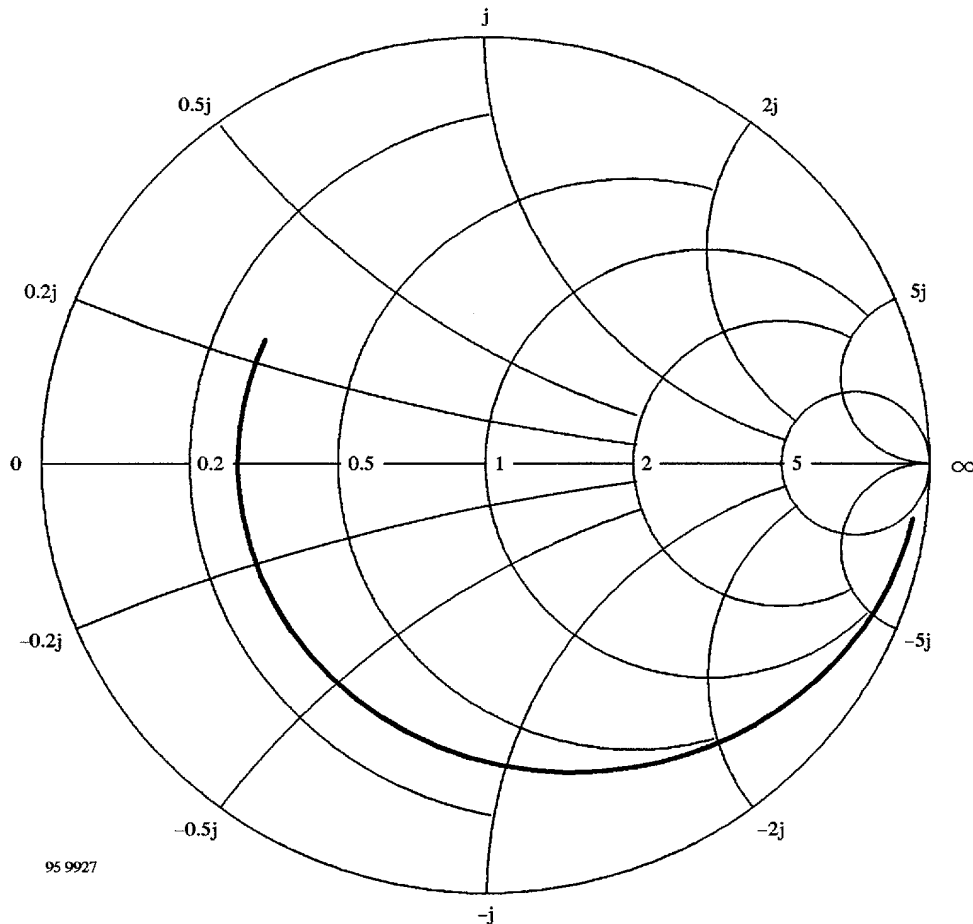
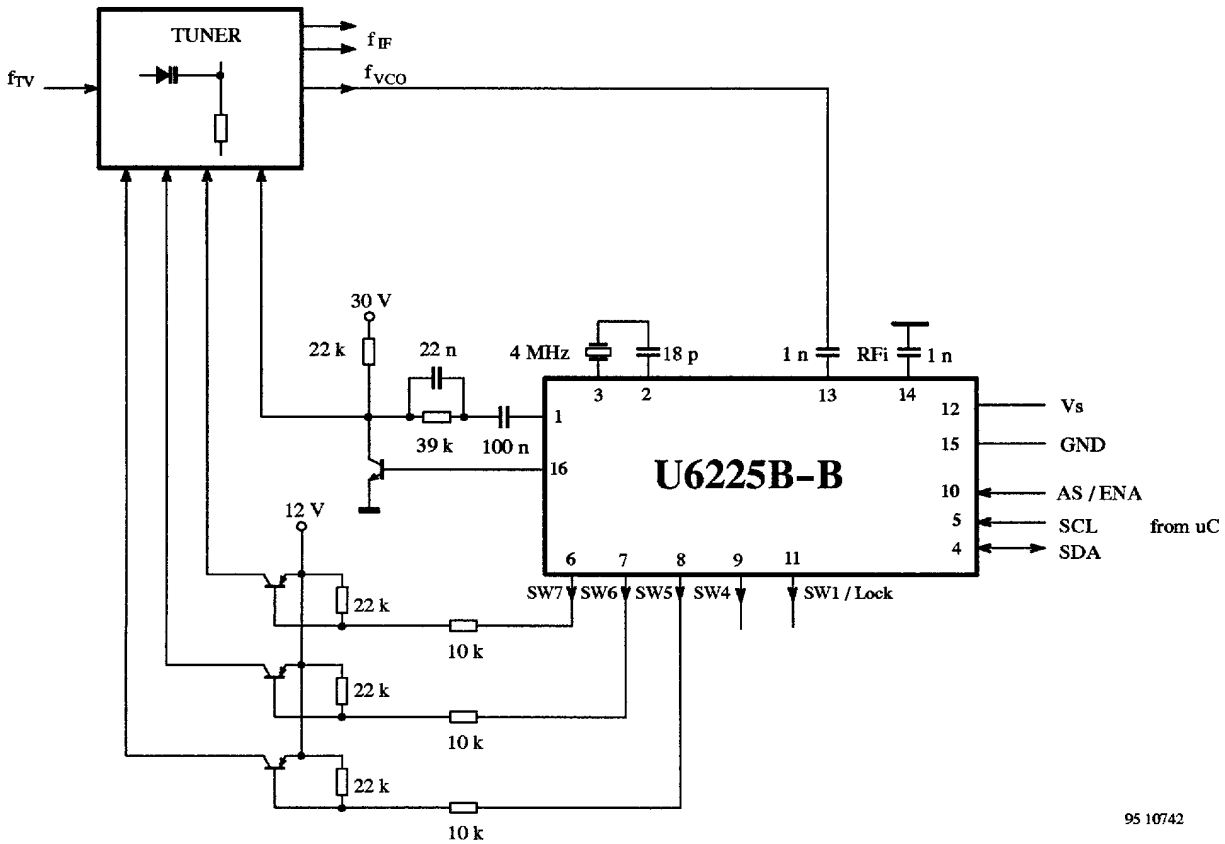

Figure 14.

U6223B-AFP

Application Circuit



95 10742

Figure 15.

Dimensions in mm

Package: SO-16 small

