

Universal Telephone IC – All Functions Integrated

Description

TEMIC's low-voltage telephone circuit U3762MB performs all the speech and line interface functions required in an electronic telephone set, the tone ringer, the

pulse and DTMF dialing with redial. Operation below 15 mA is possible with reduced performance (no dialing).

Features

Speech Circuit

- Adjustable DC characteristic
- Symmetrical input of microphone amplifier
- Receiving amplifier for dynamic or piezo-electric earpieces
- Automatic line-loss compensation
- Anti-clipping in transmit direction

Dialer

- DTMF / pulse switchable
- Pulse dialing 66/33 or 60/40 or DTMF dialing selectable by pin
- Flashing time duration 98 ms
- Pause function
- Last number redial up to 32 digits
- Standard low-cost crystal 3.57 MHz or ceramic resonator
- Key tone

Tone Ringer

- 2-tone ringer
- Adjustable volume
- RC oscillator
- Adjustable threshold

Benefits

- Low number of external components
- High quality through one IC solution

Ordering Information

Type	Package	Remarks
U3762MB-MFN	SSO44	
U3762MB-MFNG3	SSO44	Taped and reeled



Block Diagram / Applications

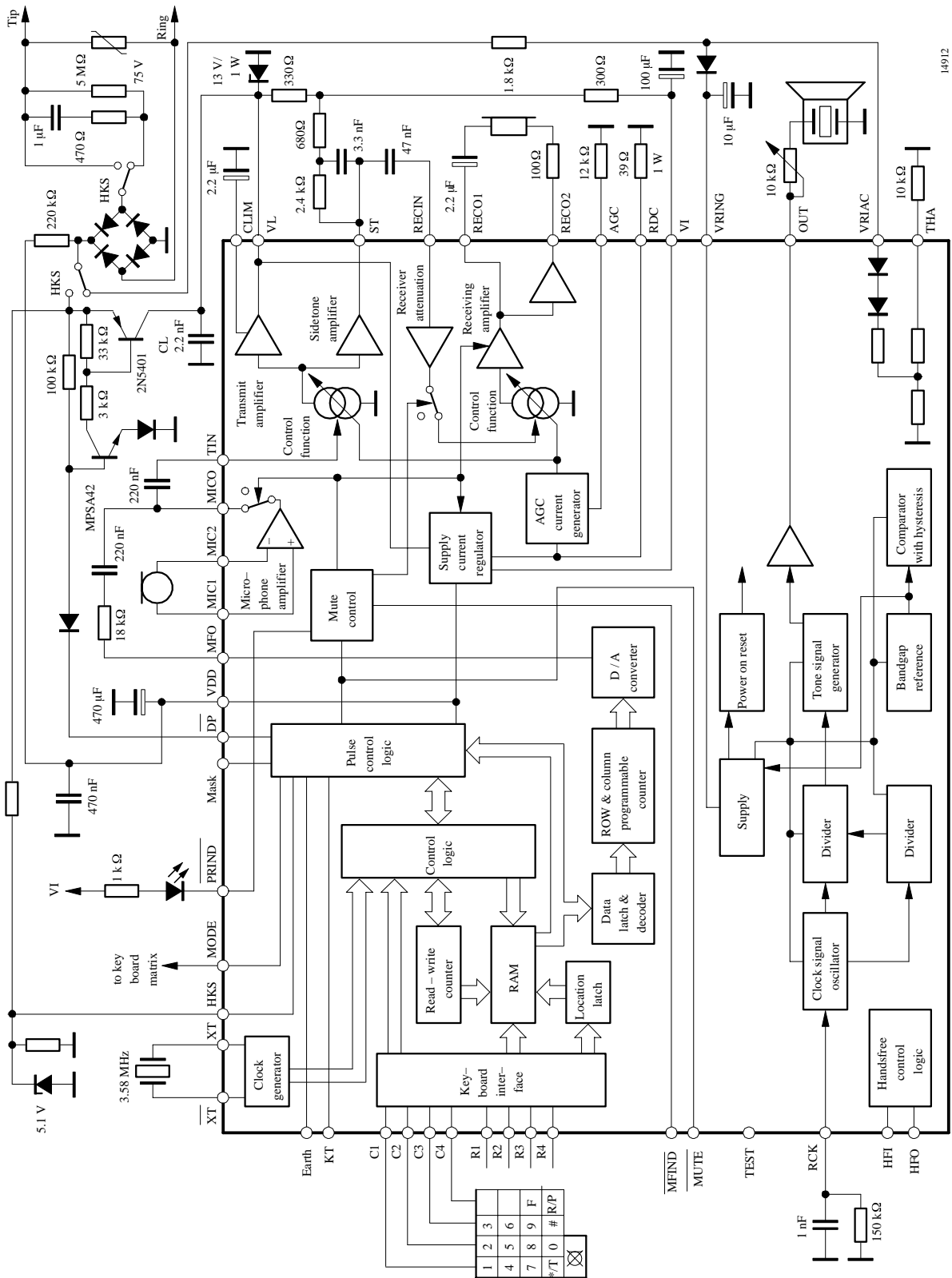
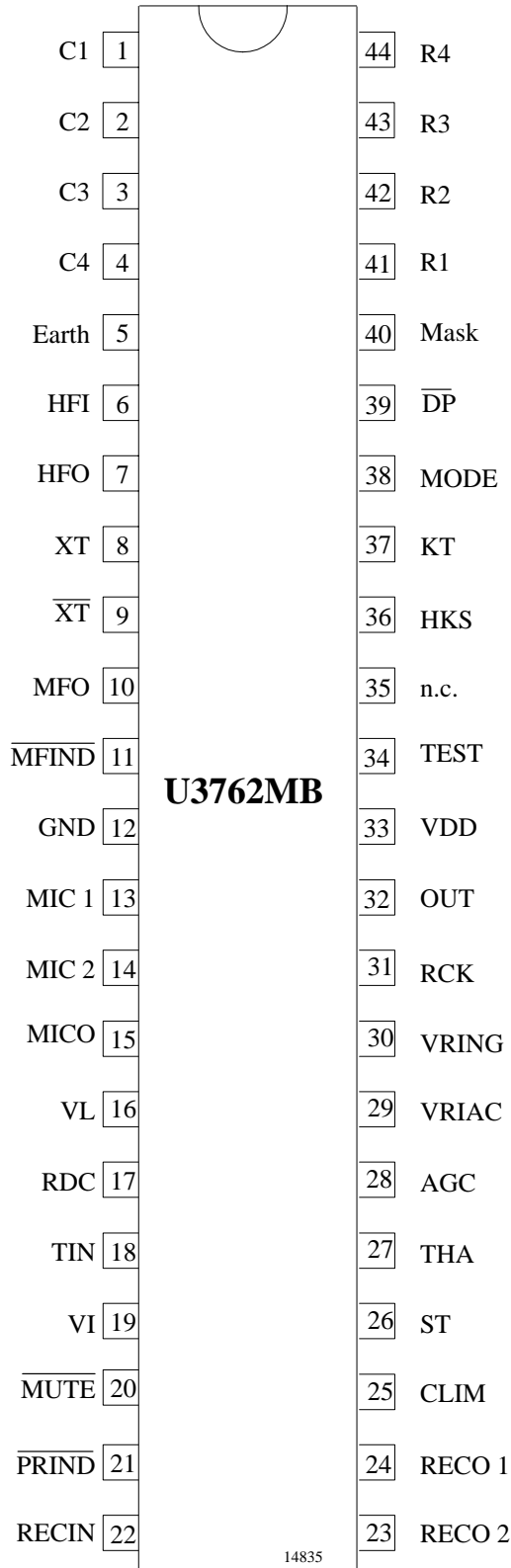

Figure 1.

Pin Description



U3762MB

Pin	Symbol	Function	Configuration																																
1	C1	Keyboard input																																	
2	C2																																		
3	C3																																		
4	C4																																		
5	Earth	Earth key (604 ms high pulse, 1 s pause)																																	
6	HFI	Input with 200 kΩ pull-down resistor. HFI triggers HFO with each LH edge.																																	
7	HFO	Output will be toggled by each LH edge at HFI.																																	
8	XT	A built-in inverter provides oscillation with an inexpensive 3.579545-MHz crystal or ceramic resonator																																	
9	$\overline{\text{XT}}$																																		
10	MFO	Output of DTMF DTMF output frequency																																	
		<table border="1"> <thead> <tr> <th></th> <th>Specified (Hz)</th> <th>Actual (Hz)</th> <th>Error (%)</th> </tr> </thead> <tbody> <tr> <td>R₁</td> <td>697</td> <td>699</td> <td>+0.28</td> </tr> <tr> <td>R₂</td> <td>770</td> <td>766</td> <td>-0.52</td> </tr> <tr> <td>R₃</td> <td>852</td> <td>848</td> <td>-0.47</td> </tr> <tr> <td>R₄</td> <td>941</td> <td>940</td> <td>-0.10</td> </tr> <tr> <td>C₁</td> <td>1209</td> <td>1216</td> <td>+0.57</td> </tr> <tr> <td>C₂</td> <td>1336</td> <td>1332</td> <td>-0.30</td> </tr> <tr> <td>C₃</td> <td>1477</td> <td>1472</td> <td>-0.34</td> </tr> </tbody> </table>			Specified (Hz)	Actual (Hz)	Error (%)	R ₁	697	699	+0.28	R ₂	770	766	-0.52	R ₃	852	848	-0.47	R ₄	941	940	-0.10	C ₁	1209	1216	+0.57	C ₂	1336	1332	-0.30	C ₃	1477	1472	-0.34
	Specified (Hz)	Actual (Hz)		Error (%)																															
R ₁	697	699		+0.28																															
R ₂	770	766		-0.52																															
R ₃	852	848		-0.47																															
R ₄	941	940		-0.10																															
C ₁	1209	1216	+0.57																																
C ₂	1336	1332	-0.30																																
C ₃	1477	1472	-0.34																																

Pin	Symbol	Function	Configuration
11	$\overline{\text{MFIND}}$	Output switches to low being in temporary DTMF mode. Reset by on hook condition.	
12	GND	Ground	
13	MIC 1	Inverting input of microphone amplifier	
14	MIC 2	Non-inverting input of microphone amplifier	
15	MICO	Transmit pre-amp output which is normally capacitively coupled to Pin TIN	
16	VL	Positive supply voltage input to the device. The current through this pin is modulated by the transmit signal.	
17	RDC	An external resistor (1 W) is required from this pin to GND to control the DC input impedance of the circuit. It has a nominal value of 39 Ω for low-voltage operation. Values up to 100 Ω may be used to increase the available transmit output voltage swing at the expense of low-voltage operation.	
18	TIN	Input to the line output driver amplifier. Transmit AGC applied to this stage.	

U3762MB

Pin	Symbol	Function	Configuration
19	V _I	This internal voltage bias line must be connected to VL via an external resistor which dominates the AC input impedance of the circuit and should be 680 Ω for an 600-Ω input impedance or 1.2 kΩ for a 900-Ω input impedance.	
20	MUTE	Pin for testing	
21	PRIND	PRIVACY indication pin Open collector with minimum 1 mA drive current to GND when PRIVACY = active	
22	RECIN	Receive amplifier input. The receiving amplification is regulated by an AGC.	
23	RECO2	Output of the receive amplifier. Dynamic transducers with a minimum impedance of 100 Ω can be directly driven by these outputs.	
24	RECO1		
25	CLIM	Time constant of anticlipping in transmit path. CLIM ≥ 2.2 μF CLIM = GND: anticlipping inactive	
26	ST	The output of the sidetone cancellation signal, which requires a balanced impedance of 8 to 10 times the subscribers line impedance to be connected to Pin VL.	
27	THA	Ringer threshold adjustment	
28	AGC	The range of transmit and receive gain variations between short and long loops may be adjusted by connecting a resistor R _{AGC} from this pin to (GND). This pin can be left open to set AGC out of action.	
29	VRIAC	Ringing supply	

Pin	Symbol	Function	Configuration
30	VRING	DC supply voltage for the tone ringer is limited to 30 V with integrated Z-diode.	
31	RCK	RC clock oscillator for ringer	
32	OUT	Buzzer output	
33	VDD	Supply output for dialer part	
34	TEST	TEST input with 6.25 kΩ pull-up resistor	
35	n.c.	Not connected	
36	HKS	Hook switch input. HKS = 0: On-hook state. Chip in sleep mode, no operation (with a pull-down resistor of about 400 kΩ). HKS = 1: Off-hook state. Chip enable for normal operation.	
37	KT	Keytone output only sent out in pulse mode	

Pin	Symbol	Function	Configuration
38	MODE	Pulling MODE pin to: C3 tone mode with 87 ms burst time and 140 ms pause C4 tone mode with 87 ms DTMF burst and 87 ms pause R1 pulse mode with 20 pps, Make/Break = 40/60 R2 pulse mode with 20 pps, Make/Break = 33/66 R3 pulse mode with 10 pps, Make/Break = 40/60 R4 pulse mode with 10 pps, Make/Break = 33/66 C1 pulse mode with 10 pps, Make/Break = 33/66 and temp. DTMF with 87 ms DTMF burst, 140 ms pause MODE pin pulled to R4: with temporary DTMF, 87 ms DTMF burst and 87 ms pause	
39	\overline{DP}	Pulse dialing output. Flash key will cause \overline{DP} to be active in either DTMF mode or pulse mode. In On-hook state is $\overline{DP} = VDD$.	
40	Mask	Short mute during pulse dialing, active high	
41	R1	Keyboard input	
42	R2		
43	R3		
44	R4		

Keyboard Operation

C1	C2	C3	C4	
1	2	3		R1
4	5	6		R2
7	8	9	F	R3
* / T	0	#	R/P	R4
⊗				

- R/P: Redial and pause function key
- F: Flash key
- * / T: * function;
pulse-to-tone function
- ⊗ : hand set, MIC mute

Normal Dialing

[OFF HOOK] , [D1] , [D2] , ..., [Dn]

1. D1, D2, ..., Dn will be dialed out.
2. Dialing length is unlimited, but redial is inhibited if length oversteps 32 digits.
3. If redialing length oversteps 32 digits, the redialing function will be inhibited.

Redialing

[OFF HOOK] , [D1] , [D2] , ..., [Dn] BUSY, Come [ON HOOK] , [OFF HOOK] , [R/P]

The [R/P] key can execute the redial function only as the first key-in after off-hook; otherwise, it executes the pause function (3.6 s).
Keys stored in redial memory: 0 to 9, *, #, R/P, F

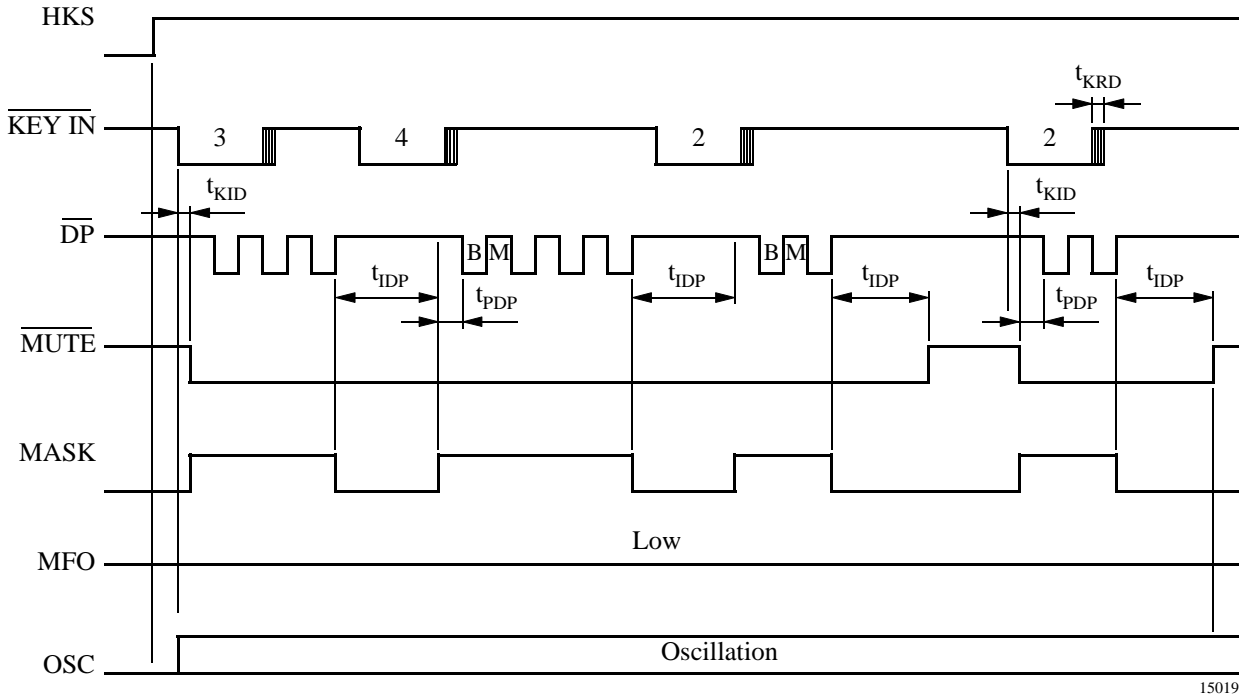

Figure 2. Pulse mode normal dialing

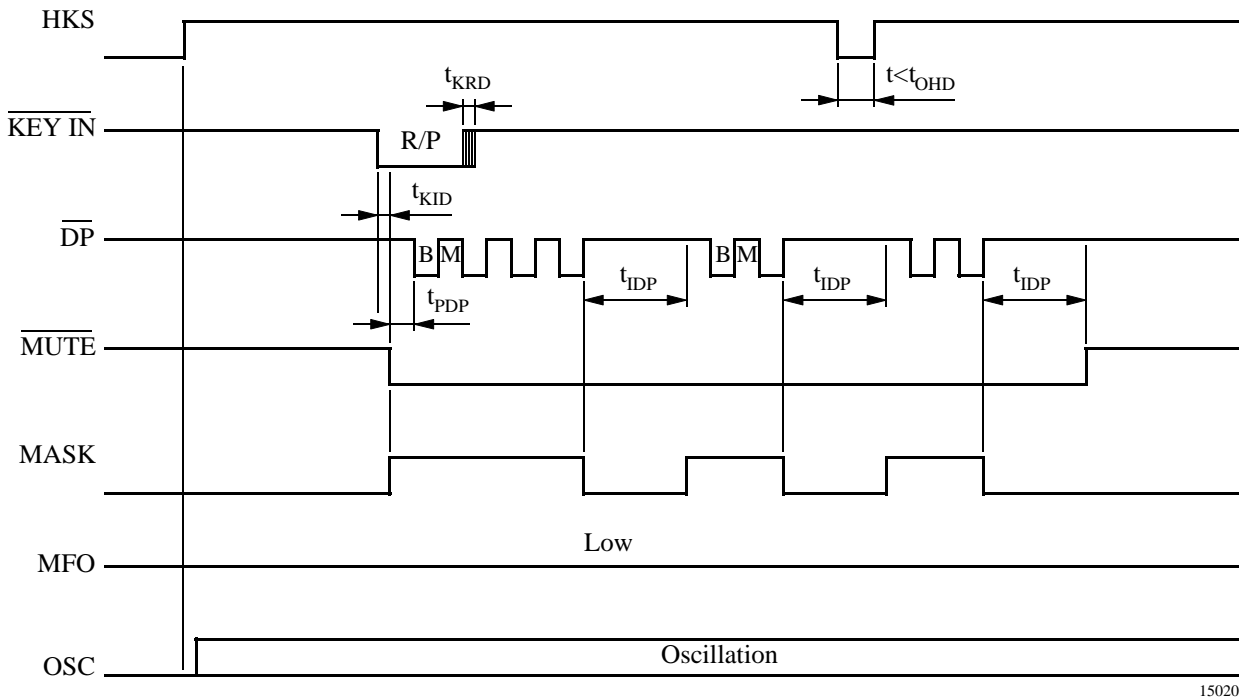

Figure 3. Pulse mode auto dialing

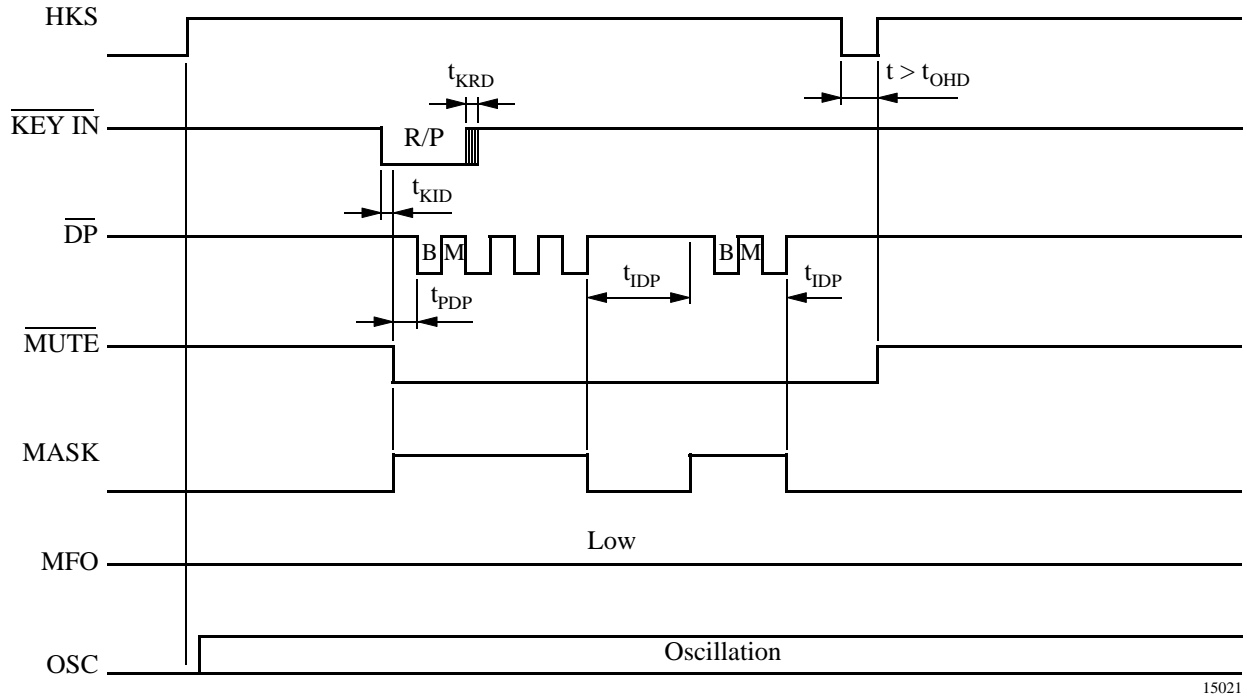

Figure 4. Pulse mode auto dialing

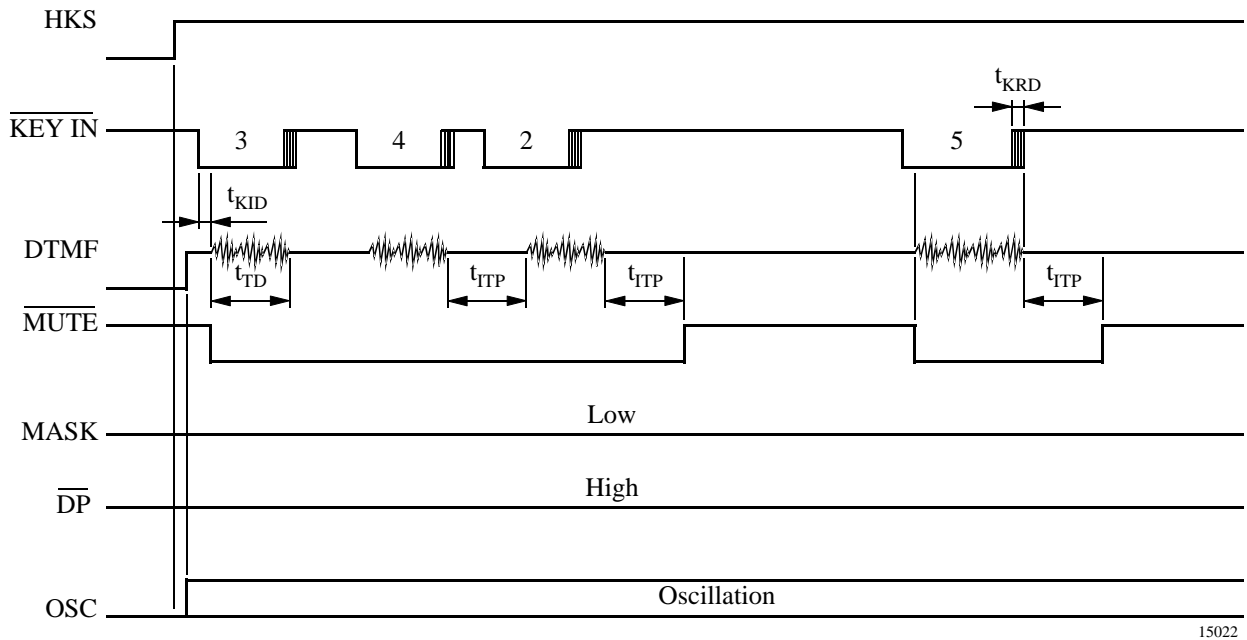

Figure 5. DTMF mode normal dialing

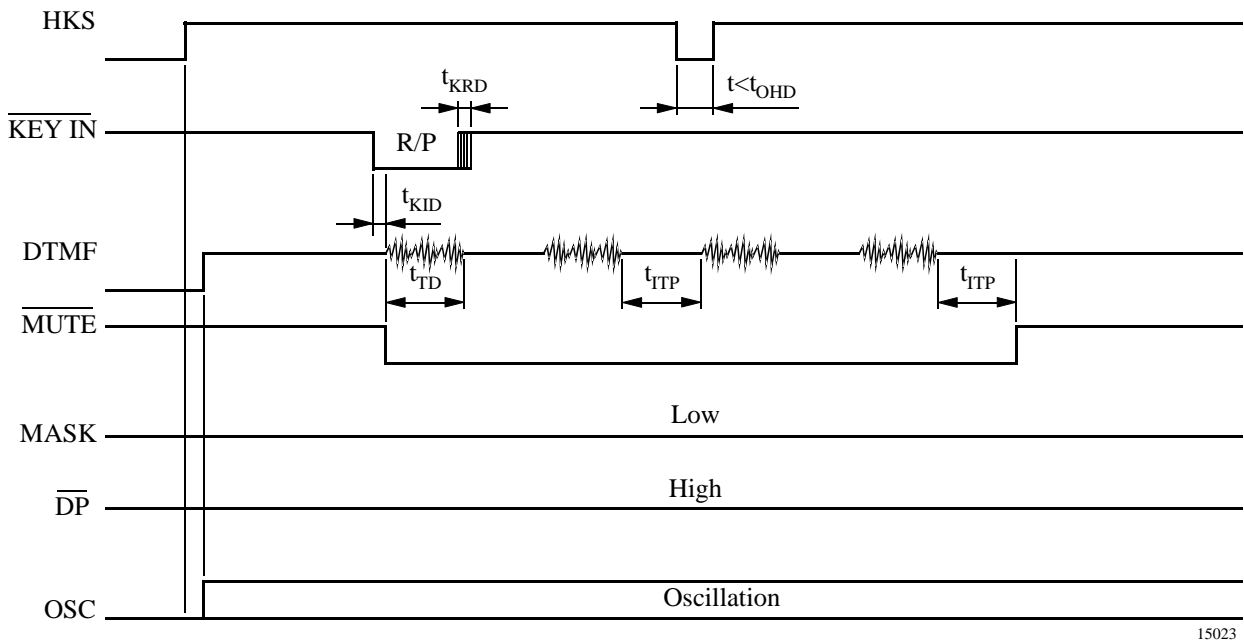

Figure 6. DTMF mode auto dialing ($t < t_{OHD}$)

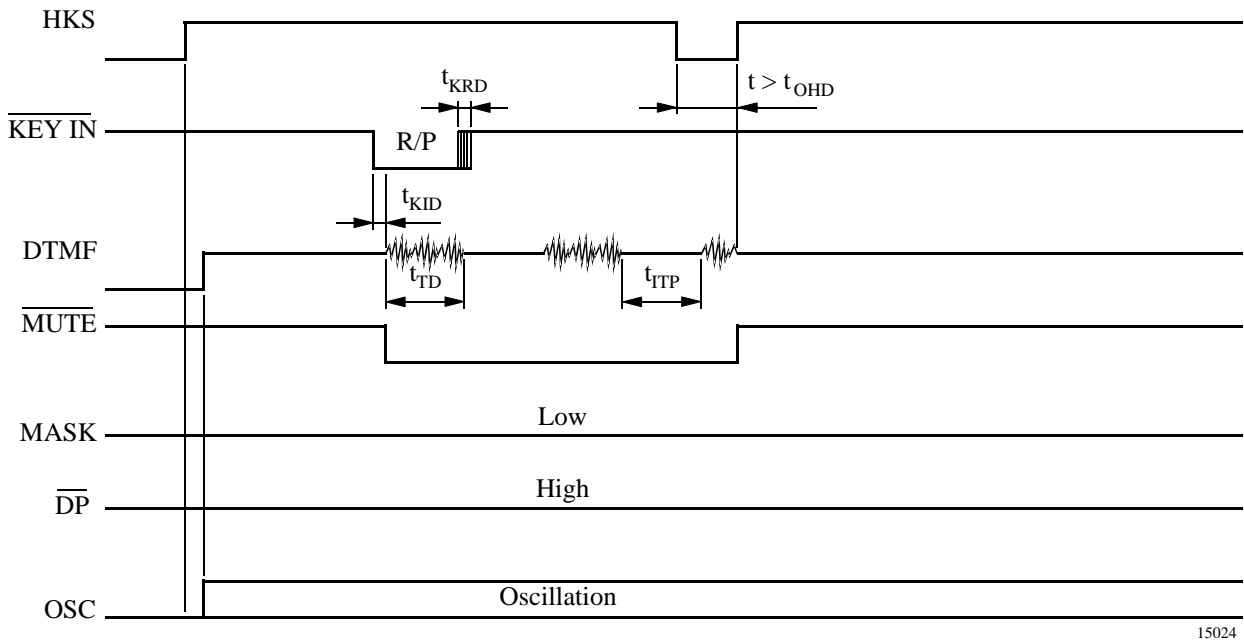
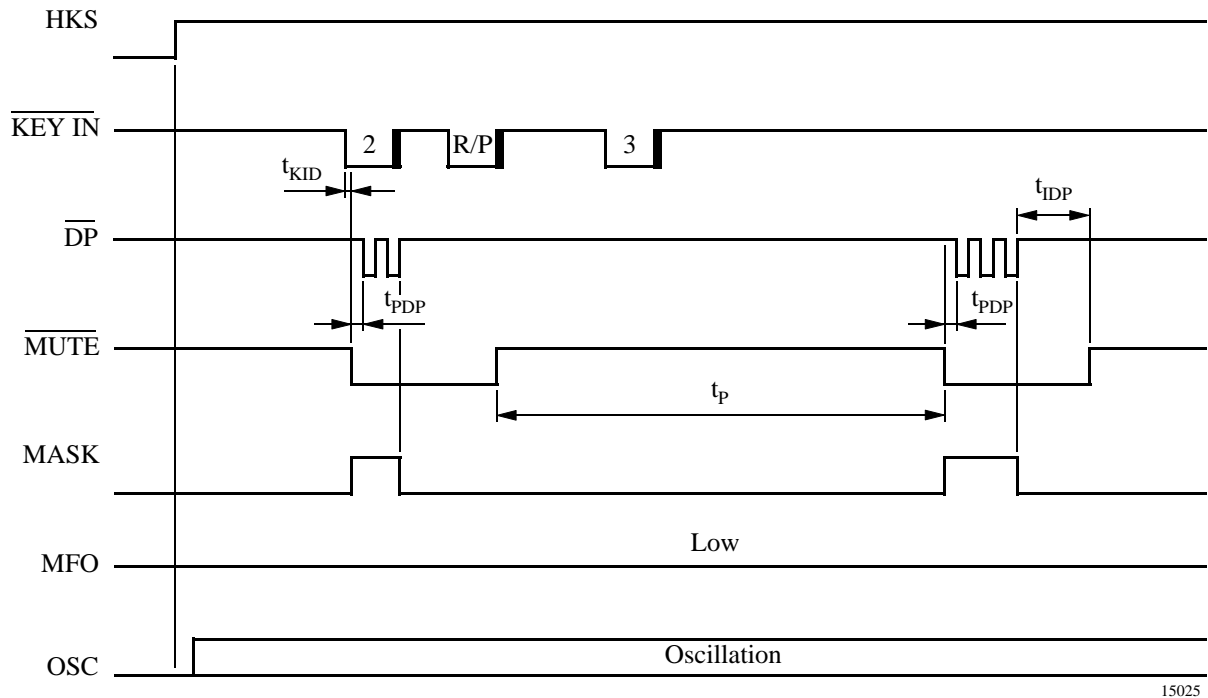

Figure 7. DTMF mode auto dialing ($t > t_{OHD}$)

Access Pause

OFF HOOK , D1 , D2 , R/P , D3 , ..., Dn'

1. The pause function can be stored in the memory.
2. The pause function is executed in normal dialing and redialing.



15025

Figure 8. Pause function

Pulse-to-Tone (* / T)

OFF HOOK , D1 , D2 , ..., Dn , * / T , D1' , D2' , ..., Dn'

1. a) If the mode switch is set to pulse mode, then the output signal will be:

D1, D2, ..., Dn, Pause (3.6 s), D1', D2', ..., Dn'
(Pulse) (Tone)

1. b) (Pulse), (Tone), (Tone) if MODE pin = C2, * is sent out as DTMF tone

2. If the mode switch is set to tone mode, then the output signal will be:

D1, D2, ..., Dn, * , D1', D2', ..., Dn'
(Tone) (Tone) (Tone)

3. The dialer remains in tone mode when the digits have been dialed out and can be reset to pulse mode by going on-hook only.

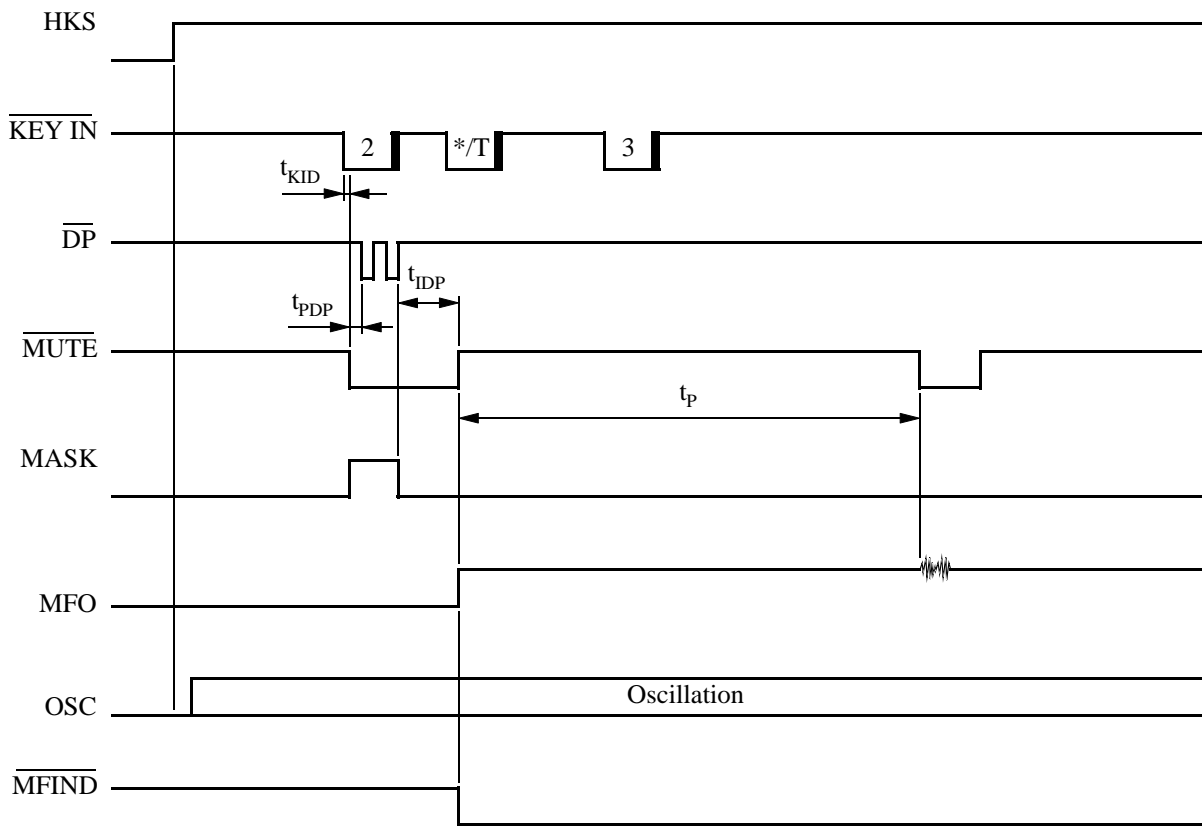

15026

Figure 9. Pulse-to-tone operation

Flash (F)

OFF HOOK , F_n

1. The dialer will execute flash break and the entire flash pause time will elapse before the next digits are dialed out.
2. The flash key can be stored as a digit in the memory. Only one flash, however, will be released to the users.
3. The system will return to the initial state after the flash pause time has elapsed.

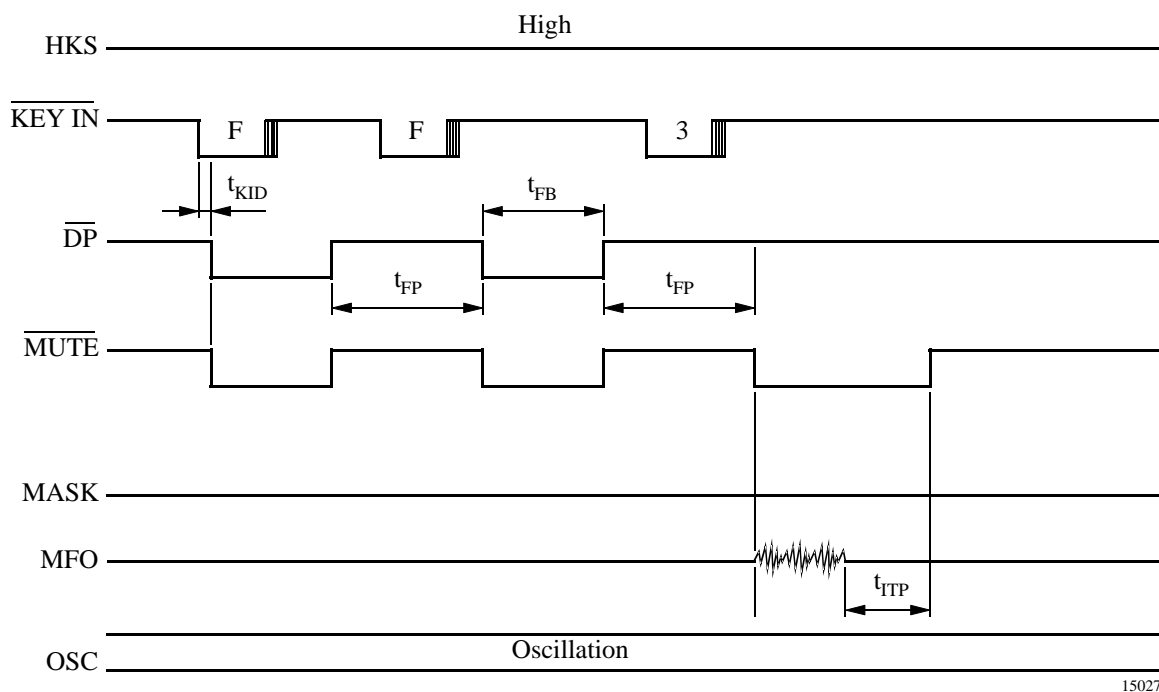

Figure 10. Flash operation

- | | |
|---|------------------------------------|
| t _{KID} = key active in debounce | t _{ITP} = intertone pause |
| t _{KRD} = key release debounce | t _{FB} = flash break time |
| t _{PDP} = pre-digit pause | t _{FP} = flash pause time |
| t _{IDP} = inter-digit pause | t _p = pause time |
| t _{TD} = DTMF output duration | |

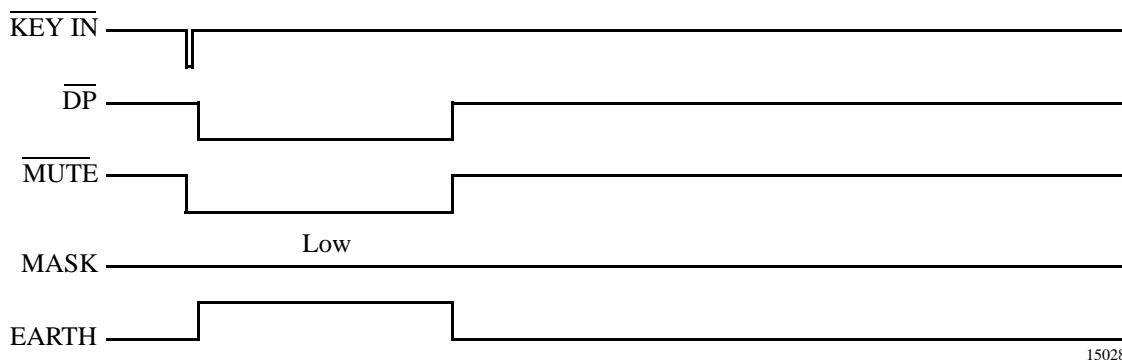

Figure 11. Symbolic timing diagram: Earth function

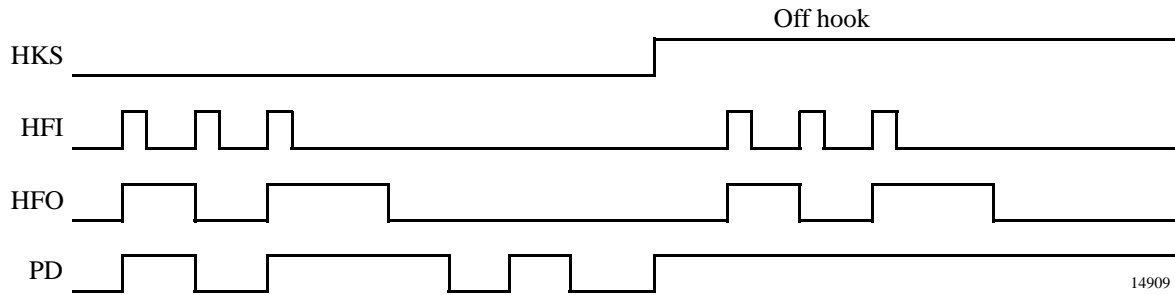

Figure 12. Symbolic timing diagram: HFI, HFO function

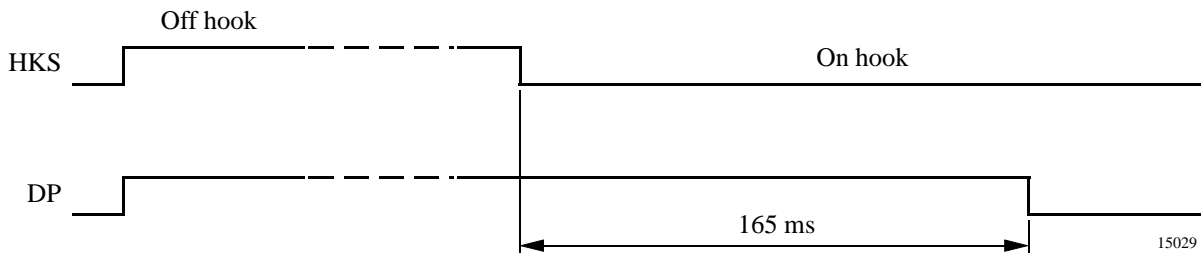

Figure 13. Symbolic timing diagram: on hook debounce time

Absolute Maximum Ratings

Parameters	Symbol	Value	Unit
Line current	I_L	140	mA
DC line voltage	V_L	14	V
Junction temperature	T_j	125	°C
Ambient temperature	T_{amb}	-25 to +75	°C
Storage temperature	T_{stg}	-55 to +150	°C
Total power dissipation, $T_{amb} = 60^\circ\text{C}$	SSO44 P_{tot}	0.9	W
Junction ambient	SSO44 R_{thJA}	70	K/W

ESD withstand voltage 1 kV according to MIL standard 883d method 3015.7 (HBM)

Electrical Characteristics Speech Circuit

Reference point Pin GND, $f = 1000 \text{ Hz}$, $0 \text{ dBm} = 775 \text{ mV}_{\text{rms}}$, $R_{\text{DC}} = 39 \Omega / 1 \text{ W}$, $T_{\text{amb}} = 25^\circ\text{C}$, unless otherwise specified, refer to “Basic Test Circuit”.

Parameters	Test Conditions / Pin	Symbol	Min.	Typ.	Max.	Unit
Line voltage	$I_L = 8 \text{ mA}$	V_L		1.4		V
	$I_L = 20 \text{ mA}$		3.6	3.85	4.1	V
	$I_L = 73 \text{ mA}$		5.9	6.55	7.2	V
	$I_L = 100 \text{ mA}$		6.9		8.2	V
Transmit and sidetone						
Input resistance	R_i	R_i	45	80	120	k Ω
Gain	$I_L = 20 \text{ mA}$, S5 = open	G_S	46.8	47.8	48.8	dB
Gain change with current	$I_L = 20 \text{ to } 60 \text{ mA}$ $R_{\text{AGC}} = \text{infinite}$	ΔG_S	-0.5		0.5	dB
Gain deviation	$T_{\text{amb}} = -10 \text{ to } +60^\circ\text{C}$ $I_L = 20 \text{ mA}$	ΔG_S	-0.5		0.5	dB
Line-loss compensation	$R_{\text{AGC}} = 12 \text{ k}\Omega$, $I_L = 73 \text{ mA}$	ΔG_S	-4.8	-6	-7	dB
Max. output voltage at line	$I_L = 20 \text{ mA}$, $V_{\text{mic}} = 10 \text{ mV}$, $\text{CLIM} = 2.2 \mu\text{F}$, S1 = open	$V_{L\text{max}}$		1.2		dBm
Noise at line weighted psophometrically	$I_L > 20 \text{ mA}$, $G_S = 48\text{dB}$	n_o			-72	dBmp
Sidetone reduction	$I_L \geq 20 \text{ mA}$	G_{STA}	10	15	20	dB
DTMF amplifier						
Volume range $d < 5\%$	Single tone, $I_L \geq 20 \text{ mA}$	V_L	1.3			dBm
DTMF output level low frequency group	$I_L = 20 \text{ mA}$, S5 = closed	V_L	-8		-4	dBm
Pre-emphasis between high- and low-level frequency group	$P_{\text{PRE}} = P_{\text{HLG}} - P_{\text{LLG}}$, S5 = closed	P_{PRE}	1		3	dB
Receiving amplifier						
Gain	$I_L \geq 20 \text{ mA}$	G_R	3		5	dB
Gain change with current	$I_L = 20 \text{ to } 60 \text{ mA}$ $R_{\text{AGC}} = \text{infinite}$	ΔG_R	-0.5		0.5	dB
Gain deviation	$T_{\text{amb}} = -10 \text{ to } +60^\circ\text{C}$ $I_L = 20 \text{ mA}$	ΔG_R	-0.3		0.7	dB
Line-loss compensation	$I_L = 73 \text{ mA}$	ΔG_R	-4.7	-6	-7	dB
Receiving noise at earphone weighted psophometrically	$I_L = 73 \text{ mA}$	n_i		-77.5	-71	dBm
Gain change when muted	$I_L \geq 20 \text{ mA}$	G_{RM}	24	29	34	dB
Output voltage push-pull	$I_L \geq 20 \text{ mA}$, $Z_{\text{ear}} = 68 \text{ nF}$, 100 Ω in series, $d \leq 2\%$	V_{RECO}	0.8	0.9		V_{rms}
Ear protection differential	$I_L = 40 \text{ mA}$, $V_{\text{gen}} = 4 V_{\text{rms}}$, $Z_{\text{ear}} = 68 \text{ nF} + 100 \Omega$	V_{ear}	1.3	1.6	2.5	V_{rms}
Supply voltage (for internal use only)						
Output voltage *	$I_L \geq 20 \text{ mA}$ dialing mode	V_{DD}	2.0		6.3	V
Available current for peripherals	$I_L \geq 20 \text{ mA}$ dialing mode	I_{DD}	150			μA
Distortion at line $V_L = 0.775 V_{\text{rms}}$	$I_L = 20 \text{ mA}$, S5 = open	d_t			2	%
Maximum output voltage swing at line	$I_L = 20 \text{ mA}$, $V_{\text{MIC}} = 50 \text{ mV}_{\text{rms}}$	$V_{L\text{max}}$		3.4	4	V_{pp}
Mute suppression transmit with privacy function	$I_L = 20 \text{ mA}$	G_{SPRIV}	60			dB

* Output must be limited externally to max. 5.5 V

DC Characteristics Dialer

$V_{DD} = 2.7$ V, $f_{OSC} = 3.58$ MHz, all outputs unloaded, S9 closed; HKS = 0

Parameters	Test Conditions / Pins	Symbol	Min.	Typ.	Max.	Unit
Memory retention current	HKS = 1, $V_{DD} = 1.0$ V	I_{MR}			0.1	μ A
Pre-emphasis	Column/Row		1	2	3	dB
DTMF distortion	$R_L = 5$ k Ω	d		-30	-23	dB
DP output sink current	$V_{PO} = 0.5$ V	I_{PL}	0.5			mA
Keyboard input drive current	$V_I = 0$ V	I_{KD}		20		μ A
Keyboard input sink current	$V_I = 2.7$ V	I_{KS}		500		μ A
Key on resistance all other keys		R_{KON}			5	k Ω
Key off resistance		R_{KOFF}		100		k Ω
Mask sink / drive current		I_M H/L	0.5			mA
Earth sink / drive current		I_e H/L	0.5			mA

AC Characteristics Dialer

Parameters	Test Conditions / Pins	Symbol	Min.	Typ.	Max.	Unit
Keypad active in debounce mode		t_{KID}	15	20	25	ms
Key release debounce		t_{KRD}	15	20	25	ms
Pre-digit pause	MODE pin = R3 (10 pps)	t_{PDP}	37	40	41	ms
	MODE pin = C1, C2, C4 (10 pps)	t_{PDP}	31	33.3	33.5	ms
	MODE pin = R1 (20 pps)	t_{PDP}		20		ms
	MODE pin = R2	t_{PDP}		16.65		ms
Inter-digit pause (auto dialing)	10 pps, $t_{IP} = t_{IDP} + t_{PDP}$	t_{IP}	810	836	860	ms
	20 pps	t_{IP}		512		ms
Make/break ratio	MODE pin = R1 (20 pps), R3 (10 pps)	M/B	40.8:60.2	40:60	39.2:60.8	%
	MODE pin = C1, C2, R4 (10 pps)		35.6:64.4	33:67	31.2:68.8	%
	R2 (20 pps)					
DTMF output duration	Auto dialing, MODE = C4	t_{TD}	84	87	90	ms
	MODE = C3		84	87	90	ms
Inter-tone pause	Auto dialing, MODE = C4	t_{TTP}	84	87	90	ms
	MODE = C3		135	140	147	ms
Flash break time, F	C4 connected to R3	t_{FB}	95	98	101	ms
Flash pause time	F	t_{FP}	0.9	1	1.1	s
Pause time		t_P	3.5	3.6	3.7	s
On-hook debounce time		t_{ohd}		220		ms

Parameters	Test Conditions / Pins	Symbol	Min.	Typ.	Max.	Unit
Break duration	MODE pin = R3	t_B	57.6	60	62.4	ms
	MODE pin = C1, C2, R4		63	66.7	69	ms
	MODE pin = R1 (20 pps)	t_B		30		ms
	MODE pin = R2			33.35		ms
Make duration	MODE pin = R3	t_M	38	40	41	ms
	MODE pin = C1, C2, R4		31	33.3	35	ms
	MODE pin = R1 (20 pps)	t_M		20		ms
	MODE pin = R2			16.65		ms
Break + make duration	MODE pin = C1, C2, R3, R4	t_P	95	100	105	ms
	MODE pin = R1, R2 (20 pps)			50		ms

Electrical Characteristics Tone Ringer

$f_{RCK} = 4 \text{ kHz}$, $V_{RING} = 20 \text{ V}$, $T_{amb} = 25^\circ\text{C}$, reference point GND, unless otherwise specified

Parameters	Test Conditions / Pins	Symbol	Min.	Typ.	Max.	Unit
Supply current, outputs open	$V_{RIAC} = 20 \text{ V}$	I_{RING}	2.1		3.8	mA
Switch-on threshold	V_{RIAC} , THA = open	V_{RON}	8	9	10	V
Switch-off threshold	V_{RIAC}	V_{ROFF}	5.0	5.6	6.5	V
Ringing frequency	$R = 150 \text{ k}\Omega$, $C = 1 \text{ nF}$ $V_{RIAC} > V_{RON}$	f_{1H}	937	1010	1083	Hz
		f_{1L}	752	808	868	Hz
Audio sequence frequency		f_2	11.5	12.5	14.0	Hz
Output voltage swing	$V_{Ring} = 25 \text{ V}$, $C_{out} = 68 \text{ nF}$	V_{out}	21	23		V_{pp}
Turn-off delay	See figure 11	t_{off}		65	100	ms

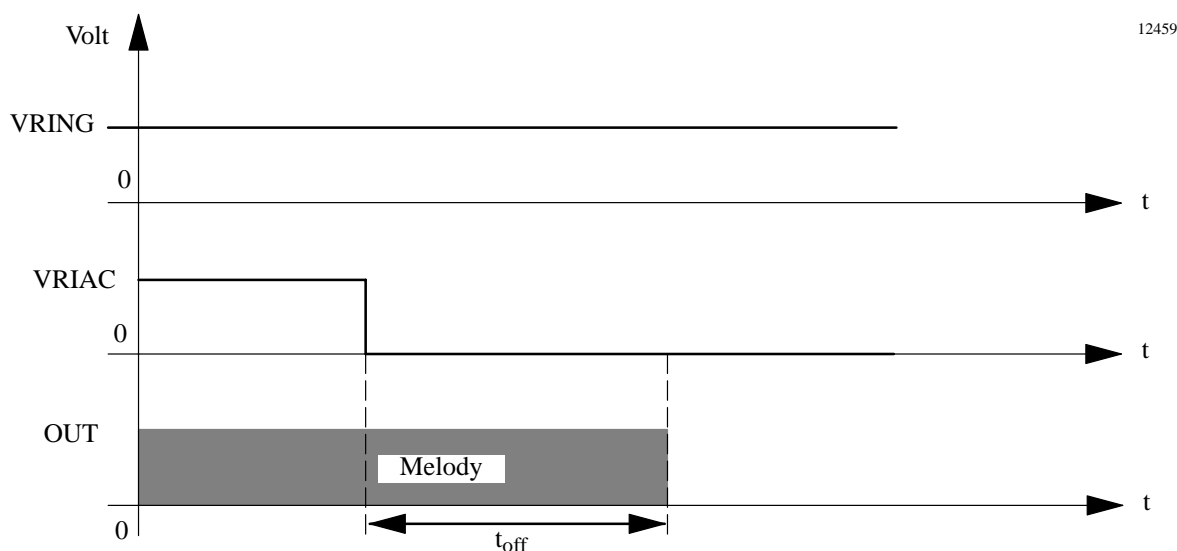

Figure 14. Turn-off delay time

Basic Test Circuit

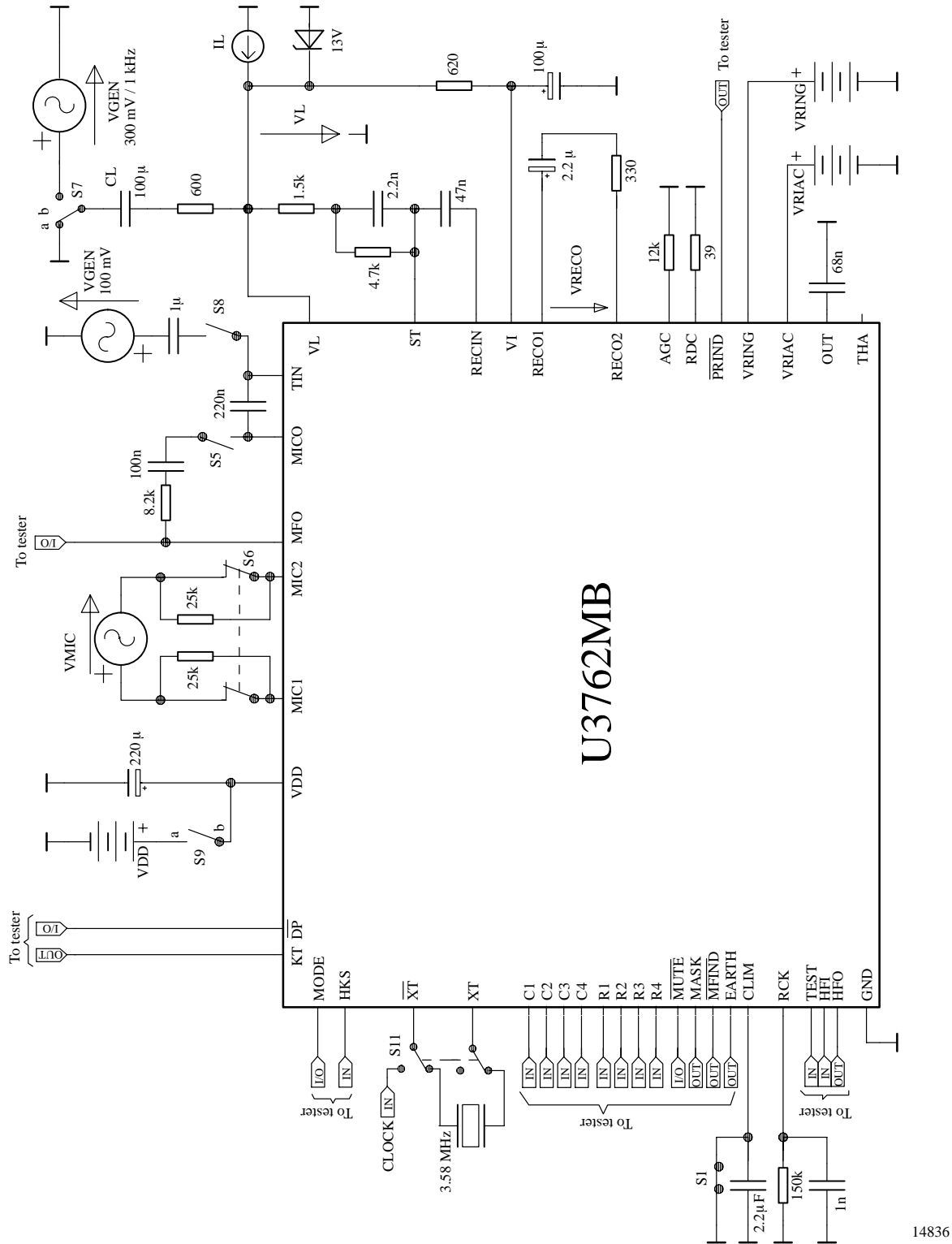

Figure 15. Basic test circuit

14836

Equations for Electrical Characteristic Parameters of the Speech Circuit

The equations refer to the basic test circuit. If not otherwise specified, the switches in the basic test circuit are inactive.

Transmit gain

$$GS = 20 \times \log \left(\frac{V_L}{V_{MIC}} \right)$$

$V_{MIC} = 3 \text{ mV/1 kHz}$, S5 = open

Receiving gain

$$GR = 20 \times \log \left(\frac{V_{RECO}}{V_L} \right)$$

RX-mode: $V_{gen} = 300 \text{ mV/1 kHz}$, S7b

Line-loss compensation transmit

$$\Delta GS = GS(\text{at } I_L = 73 \text{ mA}) - GS(\text{at } I_L = 20 \text{ mA})$$

TX-mode: $V_{MIC} = 3 \text{ mV/1 kHz}$, S5 = open

Sidetone reduction

$$GSTA = 20 \times \log \left(\frac{V_L}{V_{RECO}} \right) (\text{in TX-mode}) + GR$$

TX-mode: $V_{MIC} = 3 \text{ mV/1 kHz}$, S5 = open

Line-loss compensation receive

$$\Delta GR = GR(\text{at } I_L = 73 \text{ mA}) - GR(\text{at } I_L = 20 \text{ mA})$$

RX-mode: $V_{gen} = 300 \text{ mV/1 kHz}$, S7b

Gain change when muted

$$GRM = 20 \times \log \frac{V_{RECO}}{V_L} (\text{Mute} = \text{inactive}) - 20 \times \log \frac{V_{RECO}}{V_L} (\text{Mute} = \text{active})$$

$V_{gen} = 100 \text{ mV/1 kHz}$, S5 = open, S8 = open

Input impedance of microphone amplifier

$$R_i = \frac{50 \text{ k}}{\left(\frac{V_{L(S6 = \text{closed})}}{V_{L(S6 = \text{open})}} - 1 \right)}$$

TX-mode: $V_{MIC} = 3 \text{ mV/1 kHz}$, S5 = open

U3762MB

Packaging Information

Package SSO44
Dimensions in mm

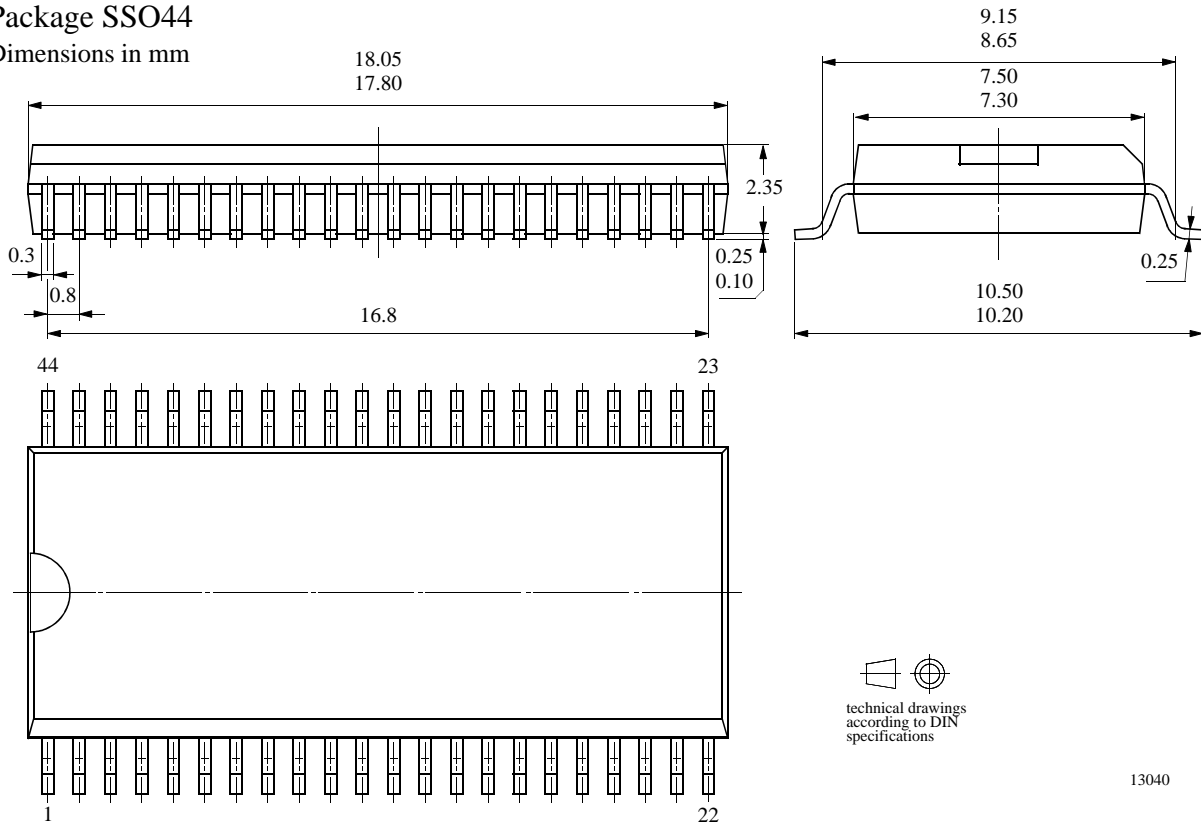

technical drawings
according to DIN
specifications

13040

Ozone Depleting Substances Policy Statement

It is the policy of **TEMIC Semiconductor GmbH** to

1. Meet all present and future national and international statutory requirements.
2. Regularly and continuously improve the performance of our products, processes, distribution and operating systems with respect to their impact on the health and safety of our employees and the public, as well as their impact on the environment.

It is particular concern to control or eliminate releases of those substances into the atmosphere which are known as ozone depleting substances (ODSs).

The Montreal Protocol (1987) and its London Amendments (1990) intend to severely restrict the use of ODSs and forbid their use within the next ten years. Various national and international initiatives are pressing for an earlier ban on these substances.

TEMIC Semiconductor GmbH has been able to use its policy of continuous improvements to eliminate the use of ODSs listed in the following documents.

1. Annex A, B and list of transitional substances of the Montreal Protocol and the London Amendments respectively
2. Class I and II ozone depleting substances in the Clean Air Act Amendments of 1990 by the Environmental Protection Agency (EPA) in the USA
3. Council Decision 88/540/EEC and 91/690/EEC Annex A, B and C (transitional substances) respectively.

TEMIC Semiconductor GmbH can certify that our semiconductors are not manufactured with ozone depleting substances and do not contain such substances.

We reserve the right to make changes to improve technical design and may do so without further notice.

Parameters can vary in different applications. All operating parameters must be validated for each customer application by the customer. Should the buyer use TEMIC products for any unintended or unauthorized application, the buyer shall indemnify TEMIC against all claims, costs, damages, and expenses, arising out of, directly or indirectly, any claim of personal damage, injury or death associated with such unintended or unauthorized use.

TEMIC Semiconductors GmbH, P.O.B. 3535, D-74025 Heilbronn, Germany
Telephone: 49 (0)7131 67 2594, Fax number: 49 (0)7131 67 2423