

L-Band Down-Converter for DAB Receivers

Description

The U2730B-B is a monolithic integrated L-band down-converter circuit fabricated in TEMIC's advanced UHF5S technology. Combining the functionality of U2754B-B and U2755B-B in one integrated circuit, it covers all functions of an L-band down-converter in a DAB receiver. The device includes a gain-controlled amplifier, a gain-controlled mixer, an output buffer, a gain-control block, an L-band oscillator and a complete frequency synthesizer unit. The frequency synthesizer

block consists of an input buffer for the reference frequency signal, a reference divider, an LO divider, a tri-state phase detector, a loop filter amplifier, a lock detector, a programmable charge pump, a test interface and a control interface.

Electrostatic sensitive device.

Observe precautions for handling.



Features

- Supply voltage: 8.5 V
- RF frequency range: 1400 MHz to 1550 MHz
- IF frequency range: 150 MHz to 250 MHz
- Overall IM3 rejection: > 40 dB
- Overall gain control range: typ. 30 dB
- DSB noise figure: 9.5 dB
- Gain-controlled amplifier
- Gain-controlled L-band mixer
- On-chip gain-control circuitry
- On-chip VCO, typical frequency 1261.568 MHz
- Internal VCO can be overdriven by an external LO
- On-chip frequency synthesizer
 - Fixed LO divider factor: 2464
 - Four reference divider factors selectable: 32, 35, 36, 48
 - Tristate phase detector with programmable charge pump
 - De-activation of tuning output programmable
 - Lock-status indication
 - Test interface

Block Diagram

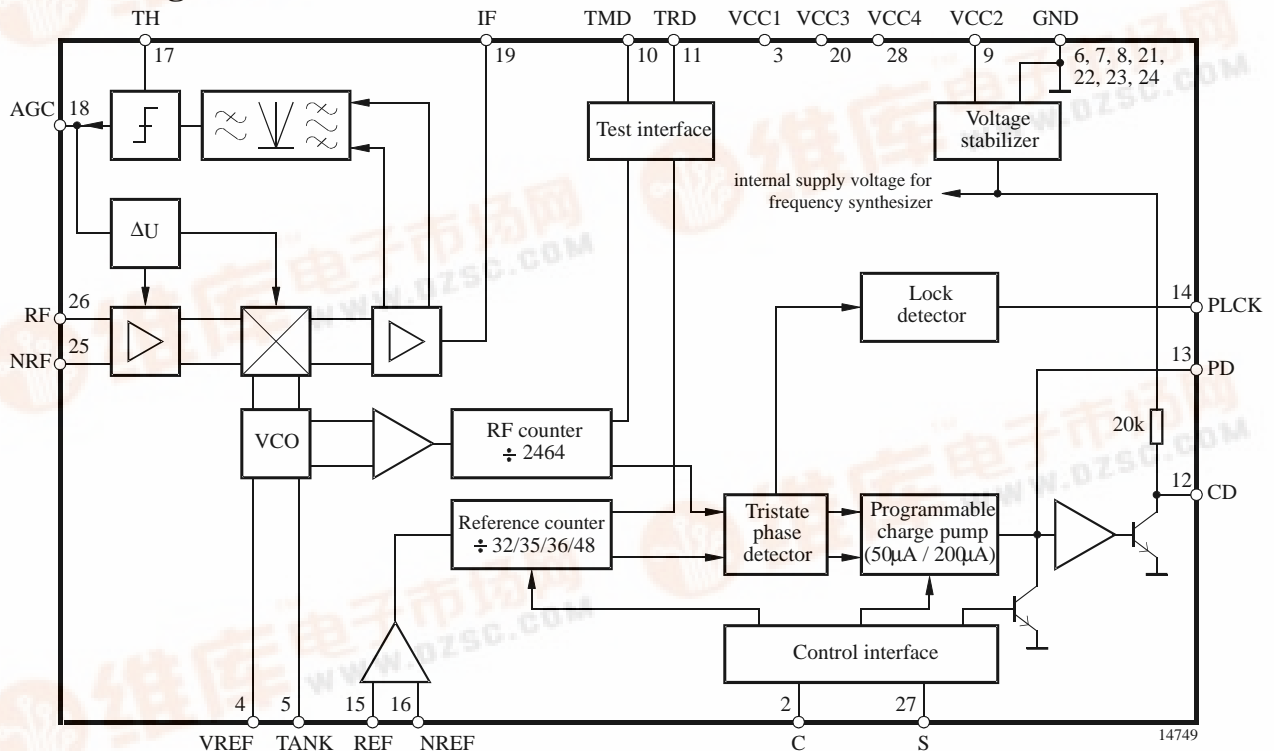

Figure 1. Block diagram



Ordering Information

Extended Type Number	Package	Remarks
U2730B-BFS	SSO28	
U2730B-BFSG1	SSO28	Taped and reeled according to IEC 286-3

Pin Description

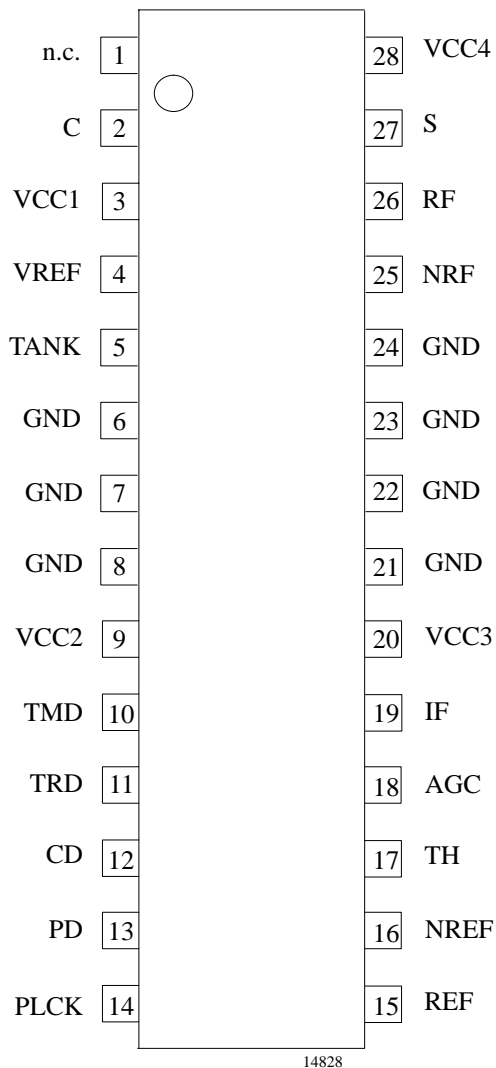

Figure 2. Pinning

Pin	Symbol	Function
1	n.c.	Not connected
2	C	Control input
3	VCC1	Supply voltage
4	VREF	Reference pin of VCO
5	TANK	Tank pin of VCO
6, 7, 8, 21, 22, 23, 24	GND	Ground
9	VCC2	Supply voltage
10	TMD	Test output of main divider
11	TRD	Test output of reference divider
12	CD	Active filter output
13	PD	Three-state charge pump output
14	PLCK	Lock-indication output (open collector)
15	REF	Reference divider input
16	NREF	Reference divider input (inverted)
17	TH	Threshold voltage of comparator
18	AGC	Charge-pump output of comparator, AGC input for amplifier and mixer
19	IF	Intermediate frequency output
20	VCC3	Supply voltage
25	NRF	RF input (inverted)
26	RF	RF input
27	S	Control input
28	VCC4	Supply voltage

Functional Description

The U2730B-B is an L-band down-converter circuit covering a gain-controlled amplifier, a gain-controlled mixer, an output buffer, a gain-control circuitry, an L-band oscillator and a frequency synthesizer block. Designed for applications in an DAB receiver, the purpose of this circuit is to down-convert incoming L-band signals in the frequency range of 1452 MHz to 1492 MHz to an IF frequency in the range of about 190 MHz to 230 MHz which can be handled by a subsequent DAB tuner. A block diagram of this circuit is shown in figure 1.

Gain-Controlled Amplifier

RF signals applied to the input Pin RF are amplified by a gain-controlled amplifier. Although the complementary Pin NRF is internally blocked, it is recommended to block this pin additionally by an external capacitor. The gain-control voltage is generated by an internal gain-control circuitry. The output signal of this amplifier is fed to a gain-controlled mixer.

Gain-Controlled Mixer and Output Buffer

The purpose of this mixer is to down-convert the L-band signal in the frequency range of 1452 MHz to 1492 MHz to an IF frequency in the range of about 190 MHz to 230 MHz. Like the amplifier, the gain of the mixer is controlled by the gain-control circuitry. The IF signal is buffered and filtered by a one-pole lowpass filter at a 3-dB frequency of about 500 MHz and then it is fed to the single-ended output Pin IF.

Gain-Control Circuitry

The purpose of the gain-control circuitry is to measure the signal power, to compare it with a certain power level and to generate control voltages for the gain-controlled amplifier and mixer. An equivalent circuit of this functional block is shown in figure 4.

In order to meet this functionality, the output signal of the buffer amplifier is weakly bandpass filtered (transition range about 60 MHz to 550 MHz), rectified, lowpass filtered and fed to a comparator whose threshold can be defined by an external resistor, R_{TH} , at Pin TH. By varying the value of this resistor, a power threshold of about -35 dBm to -25 dBm can be selected. In order to achieve a good intermodulation ratio, it is recommended to keep the power threshold below -30 dBm. An appropriate application is shown in figure 3. Depending on the selection made by the comparator, a charge pump charges or discharges a capacitor which is applied to the Pin AGC. By varying this capacitor, different time constants of the AGC loop can be realized. The voltage arising at the Pin AGC is used to control the gain setting of the gain-controlled amplifier and mixer. By applying an external voltage to the Pin AGC the internal AGC loop can be overdriven.

Voltage-Controlled Oscillator

A voltage-controlled oscillator supplies an LO signal to the mixer. An equivalent circuit of this oscillator is shown in figure 5. In the application circuits figures 3 and 5, a ceramic coaxial resonator is applied to the oscillator's Pins TANK and REF. It should be noted that the Pin REF has to be blocked carefully. Figure 6 shows a different application where the oscillator is overdriven by an external oscillator. In any case, a DC path at a low impedance must be established between the Pins TANK and REF. The output signal of the oscillator is fed to the LO divider block of the frequency synthesizer unit which locks the VCO's frequency on the frequency of a reference signal applied to the Pins REF and NREF. Figure 7 shows the typical phase-noise performance of the oscillator in locked state.

Overall Properties of the Signal Path

The overall gain of this circuit amounts 21 dB, the gain-control range is about 32 dB.

Frequency Synthesizer

The frequency synthesizer block consists of an input buffer for a reference signal, a reference divider, an LO divider to divide the frequency of the internal oscillator, a tristate phase detector, a lock detector, a programmable charge pump, a loop filter amplifier, a control interface and a test interface. The control interface is accessed by two control pins, Pins C and S. The test interface provides test signals which represent output signals of the reference and the LO divider.

The purpose of this unit is to lock the frequency, f_{VCO} , of the internal VCO on the frequency, f_{ref} , of the reference signal applied to the input Pins REF and NREF by a phase-locked loop according to the following equation:

$$f_{VCO} = SF \times f_{ref} / SF_{ref}$$

where:

$$SF = 2464$$

$$SF_{ref} = \text{scaling factor of reference divider according to the following table}$$

Voltage at Pin S (Pin 27)	SF_{ref}
Ground	35
$V_{CC}/2$	32
Open	48
V_{CC}	36

V_{CC} -supply voltage

Reference Divider

Four different scaling factors of the reference divider can be selected by the input Pin S: 32, 35, 36, 48. Starting from a reference oscillator frequency of 16.384 MHz/ 17.92 MHz/ 18.432 MHz/ 24.576 MHz these scaling factors result in an output frequency of the reference divider of 512 kHz. If the input control Pin C is left open (high-impedance state), a test signal which monitors the output frequency of the reference divider appears at the output Pin TRD of the test interface.

LO Divider

The LO divider is operated at the fixed division ratio 2464. Assuming the settings described in the section 'Reference divider', the oscillator's frequency is controlled to be 1261.568 MHz in locked state, the output frequency of the RF divider is 512 kHz. In analogy to the reference divider, a test signal which monitors the output frequency of the RF divider appears at the output Pin TMD of the test interface if the input control Pin C is left open (high-impedance state).

Phase Comparator, Charge Pump and Loop Filter

The tristate phase detector causes the charge pump to source or to sink current at the output Pin PD depending on the phase relation of its input signals which are provided by the reference and the RF divider respectively. By means of the control Pin C, two different values of this current can be selected, and furthermore the charge-pump current can be switched off.

A high-gain amplifier (output Pin CD) which is implemented to construct a loop filter, as shown in the application circuit, can be switched off by means of the control Pin C. In the application circuit figure 3, the loop filter is completed by connecting the Pins PD and CD by an appropriate RC network.

An internal lock detector checks if the phase difference of the input signals of the phase detector is smaller than approximately 250 ns in seven subsequent comparisons. If a phase lock is detected, the open collector output Pin PLCK is set to HIGH. It should be noted that the output current of this pin must be limited by external circuitry as it is not limited internally. If the voltage at the control Pin C is chosen to be half the supply voltage, or if this control pin is left open, the lock-detector function is de-activated and the logical value of the PLCK output is undefined.

Absolute Maximum Ratings

Parameters	Symbol	Value	Unit
Supply voltage Pins 3, 9, 20 and 28	V_{CC}	-0.3 to +9.5	V
RF input voltage Pins 25 and 26	V_{RF}	750	mV _{pp}
Voltage at Pin AGC Pin 18	V_{AGC}	0.5 to 6	V
Voltage at Pin TH Pin 17	V_{TH}	-0.3 to +4.0	V
Input voltage at Pin TANK (internal oscillator overdriven) Pin 5	V_{TANK}	1	V _{pp}
Current at IF output Pin 19	I_{IF}	4.0	mA
Reference input voltage (diff.) Pins 15 and 16	REF, NREF	1	V _{pp}
Control input voltage Pins 1, 2 and 27	C, S	-0.3 to +9.5	V
PLCK output current Pin 14	I_{PLCK}	0.5	mA
PLCK output voltage Pin 14	V_{PLCK}	-0.3 to +5.5	V
Junction temperature	T_j	125	°C
Storage temperature	T_{stg}	-40 to +125	°C

Operating Range

Parameters	Symbol	Min.	Typ.	Max.	Unit
Supply voltage Pins 3, 9, 20 and 28	V_{CC}	8.0	8.5	9.35	V
Ambient temperature	T_{amb}	-40		+85	°C

Thermal Resistance

Parameters	Symbol	Value	Unit
Junction ambient SSO28 (mod.)	R_{thJA}	t.b.d.	K/W

Electrical Characteristics

Operating conditions: $V_{CC} = 8.5$ V, $T_{amb} = 25^{\circ}\text{C}$, application circuit see figure 3, unless otherwise specified

Parameters	Test Conditions / Pins	Symbol	Min.	Typ.	Max.	Unit
Supply current (max. gain)	$p_{RF} = -60$ dBm	$I_{S,MAX}$	40	51	62	mA
Supply current (min. gain)	$p_{RF} = -10$ dBm	$I_{S,MIN}$	44	55	66	mA
Overall characteristics Pin 8 → 2						
Maximum conversion gain	$p_{RF} = -60$ dBm	$g_{c,max}$	18	21	24	dB
Minimum conversion gain	$p_{RF} = -10$ dBm	$g_{c,min}$	-14	-11	-8	dB
AGC range		Δg_c		32		dB
Third order 2 tone intermodulation ratio	$p_{RF1} + p_{RF2} = -6$ dBm	dim3	20	35		dB
	$p_{RF1} + p_{RF2} = -15$ dBm		30	40		dB
DSB noise figure (50- Ω system)	Maximum gain	NF		9.5		dB
	Minimum gain			30		dB
RF input Pin 26						
Frequency range		$f_{in,RF}$	1400		1550	MHz
Maximum input power	dim3 ≥ 20 dB	$p_{in,max,RF}$		-6		dBm
Input impedance		$Z_{in,RF}$		200 1		Ω pF
IF output Pin 19						
Frequency range		$f_{out,IF}$	150		250	MHz
Output impedance		$Z_{out,IF}$		50		Ω
Voltage standing wave ratio		$VSWR_{IF}$		2.0		
VCO Pin 5						
Frequency		f_{LO}	1000	1261.568	1500	MHz
Phase noise	100 kHz distance, application circuit see figure 5	L_{100kHz}		-100		dBc/Hz
Minimum input power	VCO overdriven, application circuit see figure 6	$p_{LO,MIN}$		-11		dBm
Maximum input power		$p_{LO,MAX}$		-5		dBm
Frequency synthesizer						
RF divide factor		SF		2464		
Reference divide factor	Pin S connected to GND	SF_{ref}		35		
	Pin S connected to $V_{CC}/2$			32		
	Pin S open			48		
	Pin S connected to V_{CC}			36		

Electrical Characteristics (continued)

Operating conditions: $V_{CC} = 8.5\text{ V}$, $T_{amb} = 25^\circ\text{C}$, application circuit see figure 3, unless otherwise specified

Parameters	Test Conditions / Pins	Symbol	Min.	Typ.	Max.	Unit
REF input REF, NREF Pins 15 and 16						
Input frequency range		f_{ref}	5		50	MHz
	Pin S connected to GND			17.920		MHz
	Pin S connected to $V_{CC}/2$			16.384		MHz
	Pin S open			24.576		MHz
	Pin S connected to V_{CC}			18.432		MHz
Input sensitivity		V_{refs}		10	20	mV _{rms}
Maximum input signal		V_{refmax}			300	mV _{rms}
Input impedance	Single-ended	Z_{ref}		2.7k 2.5		k Ω pF
Phase detector						
Charge-pump current	Pin C connected to V_{CC} Pin 13	I_{PD2}	± 160	± 203	± 240	μA
	Pin C connected to GND	I_{PD1}	± 40	± 50	± 60	μA
	Pin C connected to $V_{CC}/2$	$I_{PD1,tri}$			± 100	nA
Output voltage PD	Pin 2 open Pin 13	V_{PD}			0.3	V
Internal reference frequency		f_{PD}		512		kHz
Typical tuning voltage range	Pin 12	V_{tune}	0.3		5	V
Lock indication PLCK Pin 14						
Leakage current	$V_{PLCK} = 5.5\text{ V}$	I_{PLCK}			10	μA
Saturation voltage	$I_{PLCK} = 0.5\text{ mA}$	$V_{PLCK,sat}$			0.5	V
Control inputs C and S Pins 2 and 27						
Input voltage	Pin connected to GND	V_L	0		$0.1 V_{CC}$	V
	Pin connected to $V_{CC}/2$	V_M	$0.4 V_{CC}$		$0.6 V_{CC}$	V
	Pin open	V_{open}		open		
	Pin connected to V_{CC}	V_H	$0.9 V_{CC}$		1	V
Test outputs TMD, TRD Pins 10 and 11						
Frequency	Pin C open	f_{test}		512		kHz
Voltage swing	$R_{load} \geq 1\text{ M}\Omega$, $C_{load} \leq 15\text{ pF}$, Pin C open	V_{test}		400		mV _{pp}

Application Circuit

Example: reference divider factor = 35, charge-pump current = 200 μ A

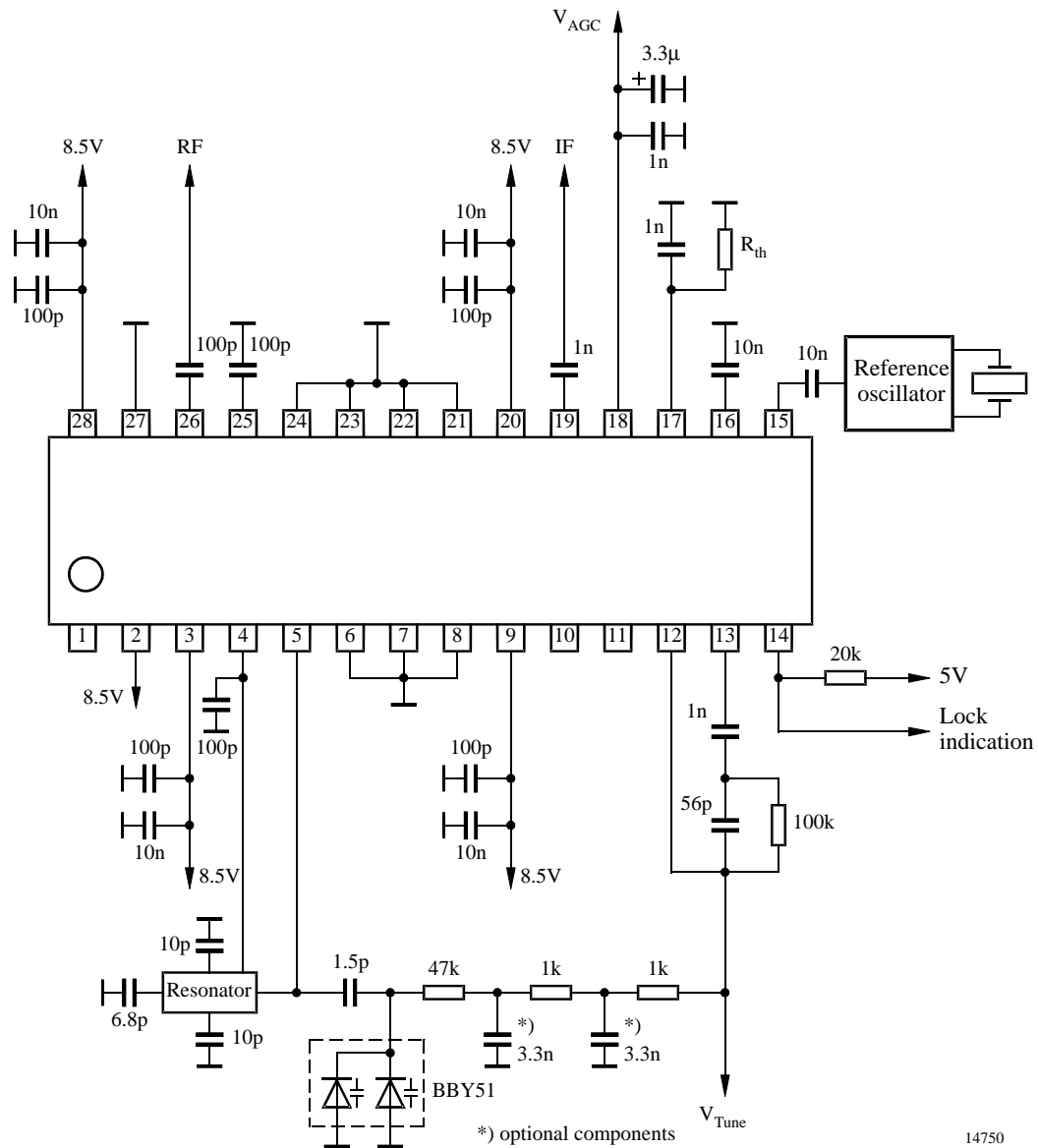

Figure 3. Application circuit

14750

Equivalent Circuits

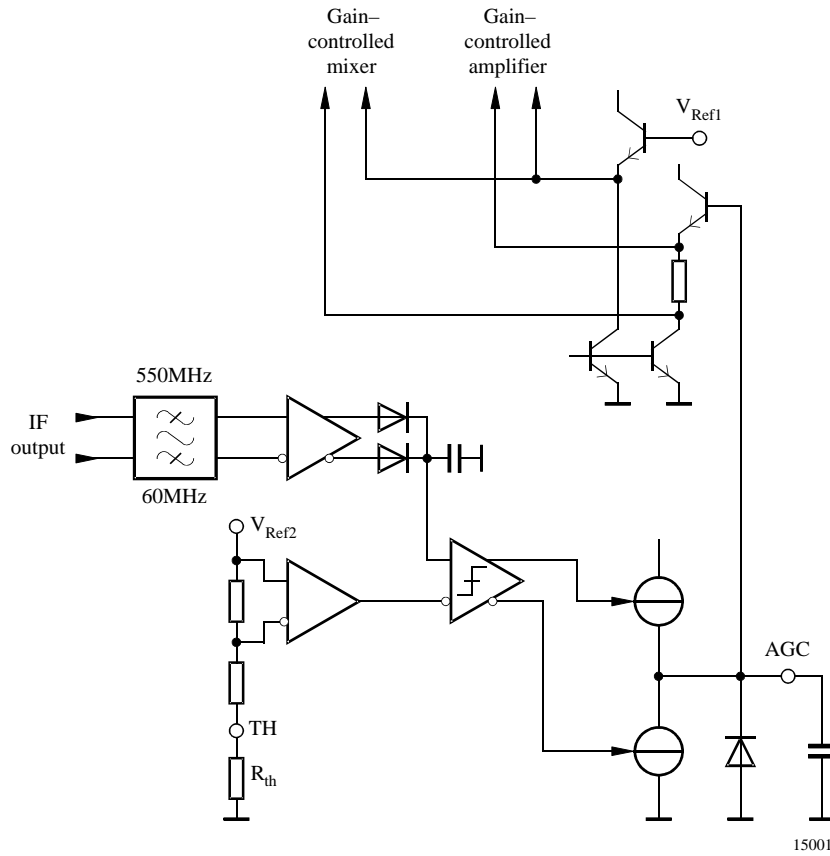
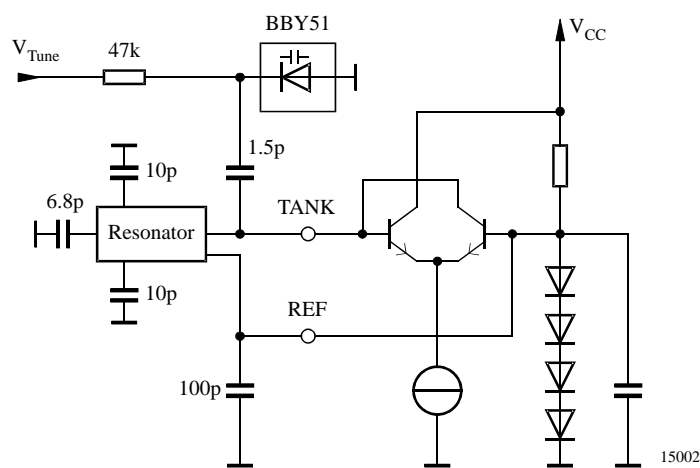

Figure 4. AGC control circuit



Resonator: Siemens Matsushita ($\lambda/4$ -Resonator)
 Ceramic Coaxial Resonator 1.6 GHz
 B69640-G 1607-B412

Notice: The VCO needs a DC-path between TANK and VREF-Pin

Figure 5. VCO circuit

Application Circuit for External LO Signal

With an external LO signal it is possible to overdrive the VCO. In this case, the internal VCO acts as an LO buffer.

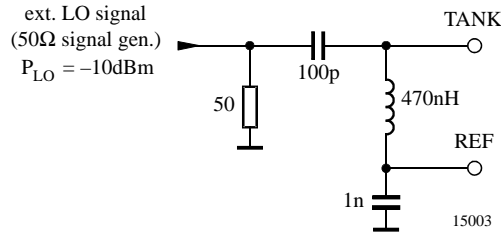

Figure 6. Application circuit for external LO signal

Phase-Noise Performance

Operating conditions

$V_{CC} = 8.5\text{ V}$, $T_{amb} = 25^\circ\text{C}$, application circuit see figure 3, $I_{PD} = 200\ \mu\text{A}$, $f_{REF} = 17.92\text{ MHz} / -10\text{ dBm}$

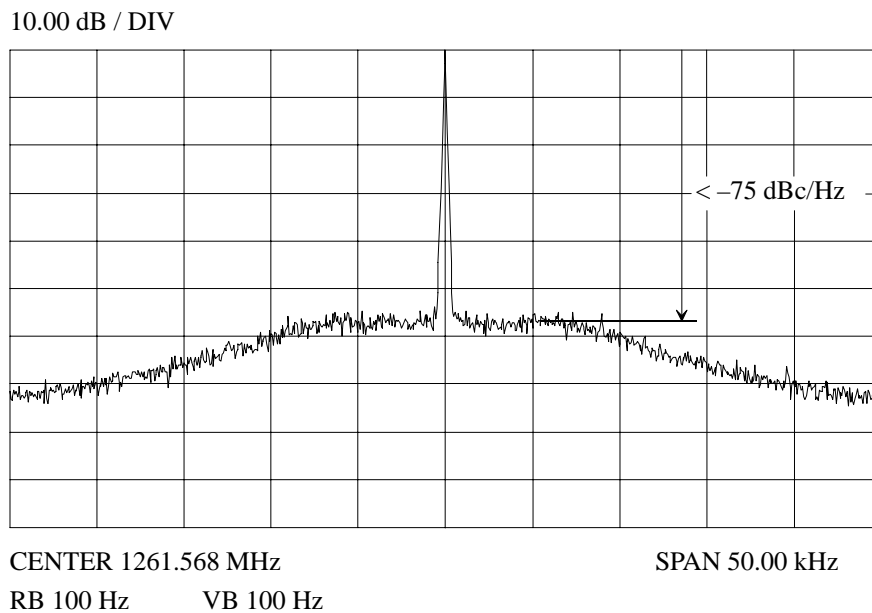

Figure 7. Phase noise

Typical Gain Control Characteristics

Operating conditions: $V_{CC} = 8.5\text{ V}$, $T_{amb} = 25\text{ C}$, $F_{RF} = 1490\text{ MHz}$, $F_{LO} = 1261.568\text{ MHz}$

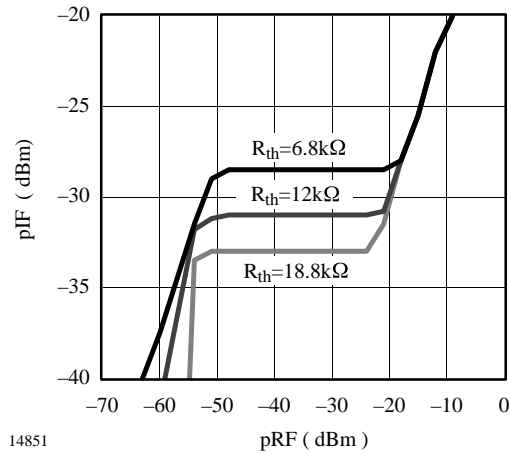

Figure 8. IF output power (Pin 19)

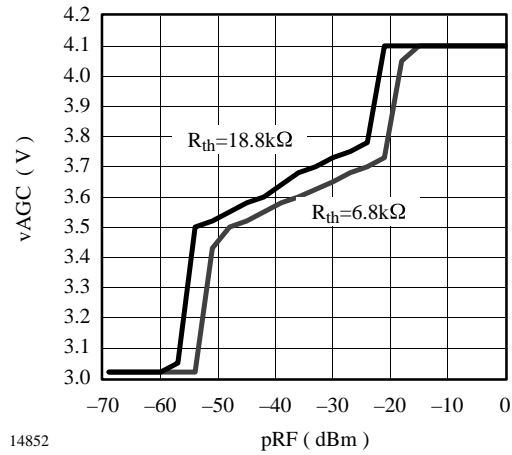

Figure 9. Gain control voltage (Pin 11)

Third Order 2-Tone Intermodulation Ratio (dim3)

Operating conditions: $f_{RF1} = 1490\text{ MHz}$, $f_{RF2} = 1491\text{ MHz}$, $p_{RF1} = p_{RF2} = p_{RF}$

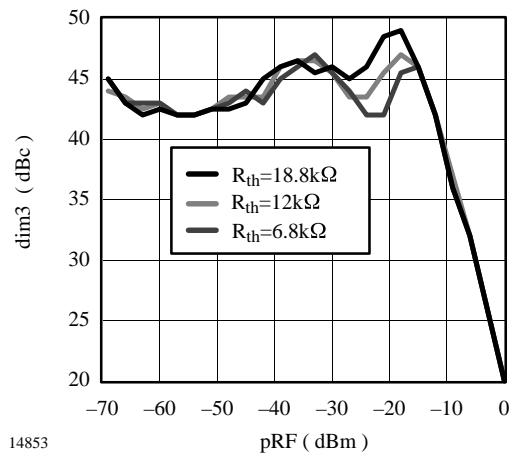

Figure 10.

Total Supply Current

Operating conditions: $R_{TH} = 12\text{ k}\Omega$, PLL locked, $I_{cp} = 200\text{ }\mu\text{A}$

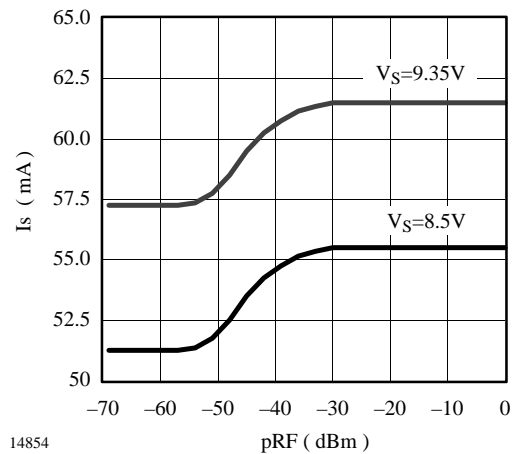
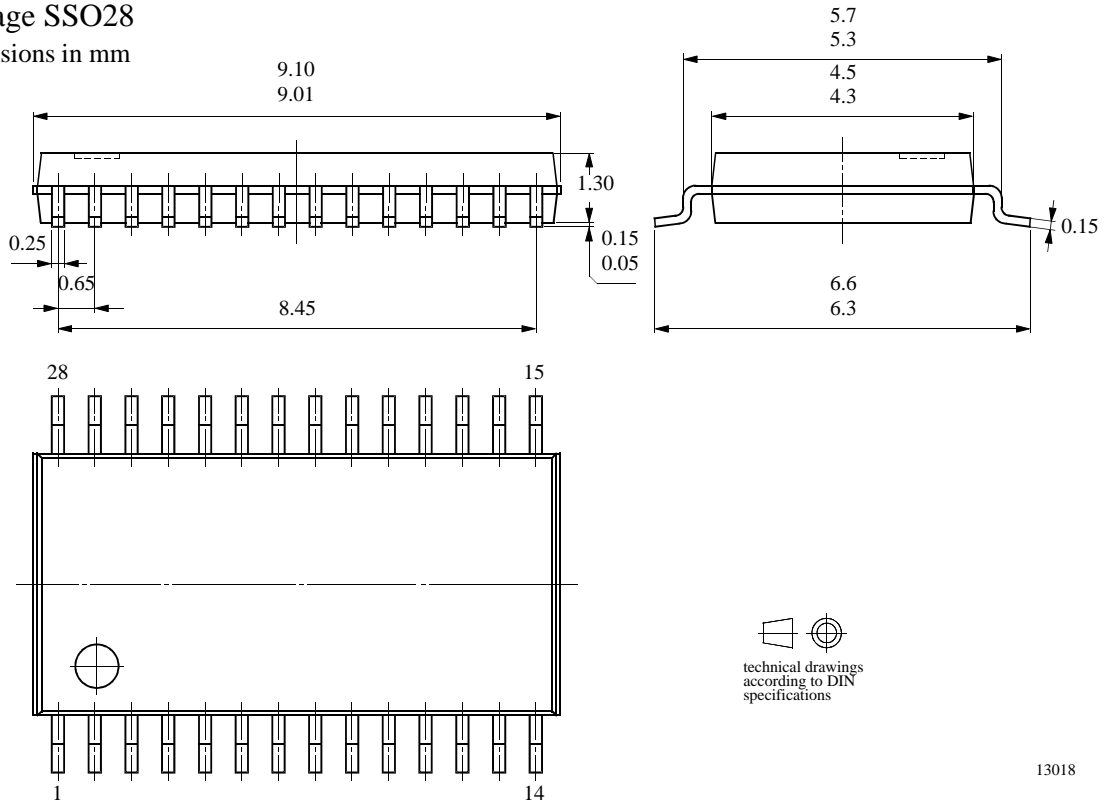

Figure 11.

Package Information

Package SSO28

Dimensions in mm



13018

Ozone Depleting Substances Policy Statement

It is the policy of **TEMIC Semiconductor GmbH** to

1. Meet all present and future national and international statutory requirements.
2. Regularly and continuously improve the performance of our products, processes, distribution and operating systems with respect to their impact on the health and safety of our employees and the public, as well as their impact on the environment.

It is particular concern to control or eliminate releases of those substances into the atmosphere which are known as ozone depleting substances (ODSs).

The Montreal Protocol (1987) and its London Amendments (1990) intend to severely restrict the use of ODSs and forbid their use within the next ten years. Various national and international initiatives are pressing for an earlier ban on these substances.

TEMIC Semiconductor GmbH has been able to use its policy of continuous improvements to eliminate the use of ODSs listed in the following documents.

1. Annex A, B and list of transitional substances of the Montreal Protocol and the London Amendments respectively
2. Class I and II ozone depleting substances in the Clean Air Act Amendments of 1990 by the Environmental Protection Agency (EPA) in the USA
3. Council Decision 88/540/EEC and 91/690/EEC Annex A, B and C (transitional substances) respectively.

TEMIC Semiconductor GmbH can certify that our semiconductors are not manufactured with ozone depleting substances and do not contain such substances.

We reserve the right to make changes to improve technical design and may do so without further notice.

Parameters can vary in different applications. All operating parameters must be validated for each customer application by the customer. Should the buyer use TEMIC products for any unintended or unauthorized application, the buyer shall indemnify TEMIC against all claims, costs, damages, and expenses, arising out of, directly or indirectly, any claim of personal damage, injury or death associated with such unintended or unauthorized use.

TEMIC Semiconductor GmbH, P.O.B. 3535, D-74025 Heilbronn, Germany
Telephone: 49 (0)7131 67 2831, Fax number: 49 (0)7131 67 2423