



U10C30 thru U10C60

**Switchmode
Dual Ultrafast Power Rectifiers**

-- Designed for use in switching power supplies inverters and as free wheeling diodes. These state-of-the-art devices have the following features:

- * High Surge Capacity
- * Low Power Loss, High efficiency
- * Glass Passivated chip junctions
- * 150 °C Operating Junction Temperature
- * Low Stored Charge Majority Carrier Conduction
- * Low Forward Voltage, High Current Capability
- * High-Switching Speed 50 Nanosecong Recovery Time
- * Plastic Material used Carries Underwriters Laboratory Flammability Classification 94V-O

**ULTRA FAST
RECTIFIERS**

**10 AMPERES
300-600 VOLTS**

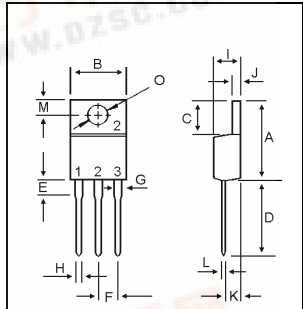
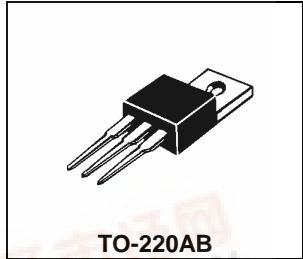

DIM	MILLIMETERS	
	MIN	MAX
A	14.68	15.32
B	9.78	10.42
C	6.02	6.52
D	13.06	14.62
E	3.57	4.07
F	2.42	2.66
G	1.12	1.36
H	0.72	0.96
I	4.22	4.98
J	1.14	1.38
K	2.20	2.98
L	0.33	0.55
M	2.48	2.98
O	3.70	3.90

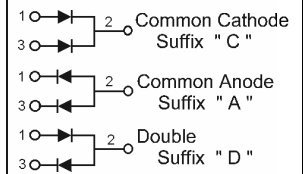

MAXIMUM RATINGS

Characteristic	Symbol	U10C30	U10C40	U10C50	U10C60	Unit
Peak Repetitive Reverse Voltage Working Peak Reverse Voltage DC Blocking Voltage	V_{RRM} V_{RWM} V_R	300	400	500	600	V
RMS Reverse Voltage	$V_{R(RMS)}$	210	280	350	420	V
Average Rectifier Forward Current Total Device (Rated V_R), $T_C=100$	$I_{F(AV)}$	5.0 10				A
Peak Repetitive Forward Current (Rate V_R , Square Wave, 20kHz)	I_{FM}	10				A
Non-Repetitive Peak Surge Current (Surge applied at rate load conditions halfwave, single phase, 60Hz)	I_{FSM}	100				A
Operating and Storage Junction Temperature Range	T_J, T_{stg}	-65 to +150				

ELECTRIAL CHARACTERISTICS

Characteristic	Symbol	U10C30	U10C40	U10C50	U10C60	Unit
Maximum Instantaneous Forward Voltage ($I_F=5.0$ Amp $T_C=25$) ($I_F=5.0$ Amp $T_C=125$)	V_F	1.30 1.16		1.50 1.38		V
Maximum Instantaneous Reverse Current (Rated DC Voltage, $T_C=25$) (Rated DC Voltage, $T_C=125$)	I_R		5.0 200			μ A
Reverse Recovery Time ($I_F=0.5$ A, $I_R=1.0$, $I_{rr}=0.25$ A)	T_{rr}	50				ns
Typical Junction Capacitance (Reverse Voltage of 4 volts & $f=1$ MHz)	C_P	70		60		pF



U10C30 Thru U10C60

FIG-1 TYPICAL FORWARD CHARACTERISTICS

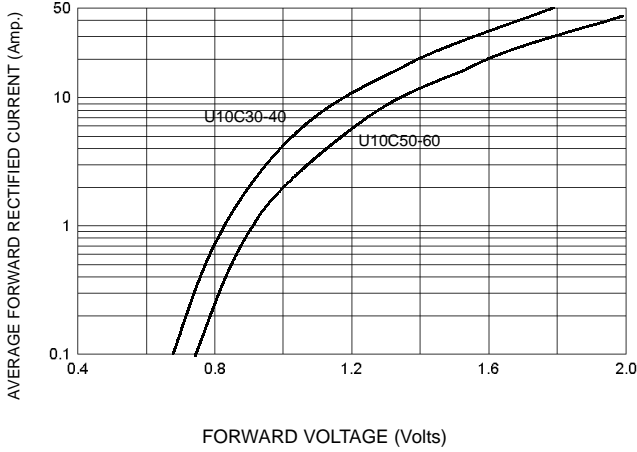

FIG-3 FORWARD CURRENT DERATING CURVE

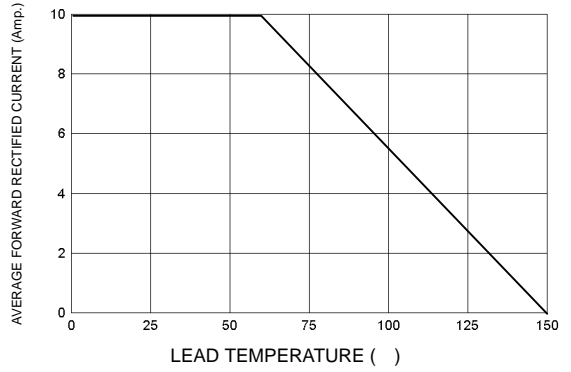

FIG-2 TYPICAL REVERSE CHARACTERISTICS

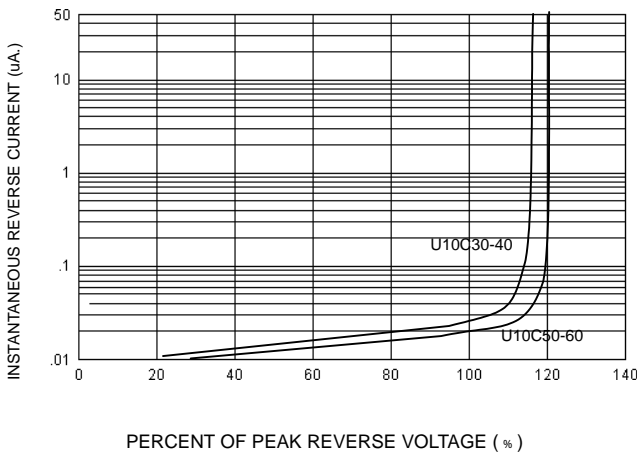

FIG-4 TYPICAL JUNCTION CAPACITANCE

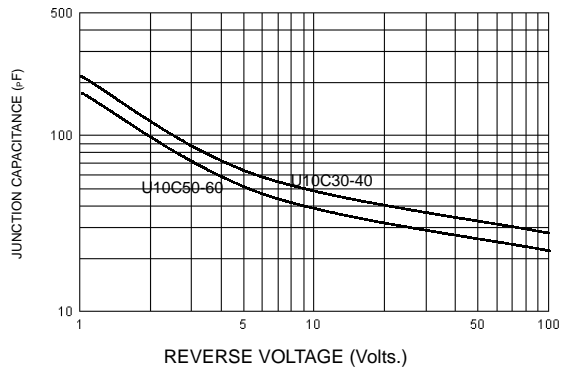
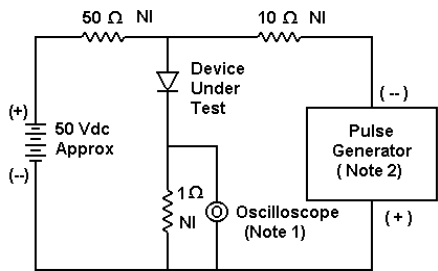
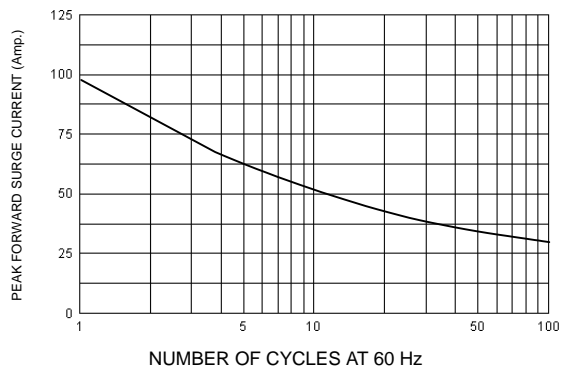
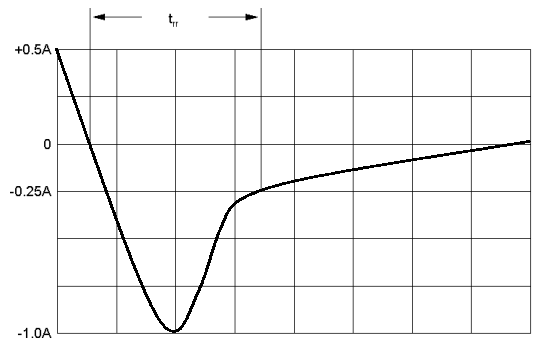

FIG-5 PEAK FORWARD SURGE CURRENT



- Notes:
 1. Rise Time = 7 ns max. Input Impedance = 1 M Ω , 22 pF
 2. Rise Time = 10 ns max. Input Impedance = 50 Ω



Set time base for 10/20 ns/cm

FIG-6 Reverse Recovery Time Characteristic and Test Circuit Diagram