



# TS321

## LOW POWER SINGLE OPERATIONAL AMPLIFIER

- LARGE OUTPUT VOLTAGE SWING :
  - 0 to 3.5V min. (@V<sub>CC</sub> = 5V)
- LOW SUPPLY CURRENT : 500µA
- LOW INPUT BIAS CURRENT : 20nA
- LOW INPUT OFFSET VOLTAGE : 2mV max.
- WIDE POWER SUPPLY RANGE :
  - SINGLE SUPPLY : +3V TO +30V
  - DUAL SUPPLIES : ±1.5V TO ±15V
- STABLE WITH HIGH CAPACITIVE LOADS

### DESCRIPTION

The TS321 is intended for cost sensitive applications where space saving is of great importance. This bipolar Op-Amp offers the benefits of a reduced component size (SOT23-5 package), with specifications that match (or better) industry standard devices (like the popular LM358A, LM324, etc.). The TS321 has an input common mode range (Vicm) that includes ground, therefore can be employed in single supply applications.

### ORDER CODE

Part Number	Temperature Range	Package		SOT23 Marking
		D	L	
TS321I	-40°C, +125°C	•	•	K401
TS321AI		•	•	K402

D = Small Outline Package (SO) - also available in Tape & Reel (DT)  
 L = Tiny Package (SOT23-5) - only available in Tape & Reel (LT)

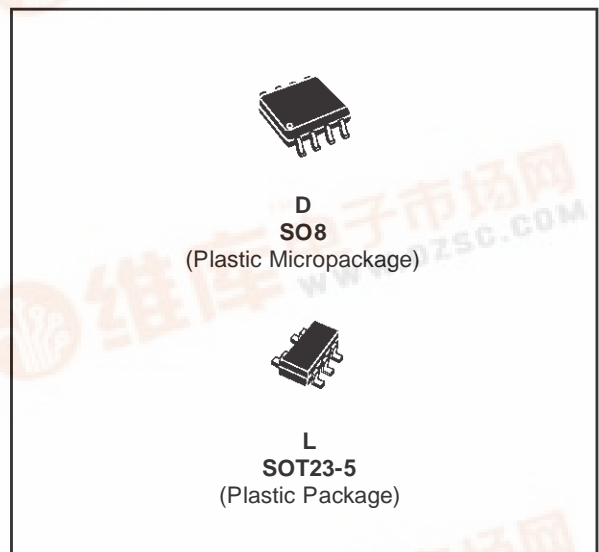

### PIN CONNECTIONS (top view)

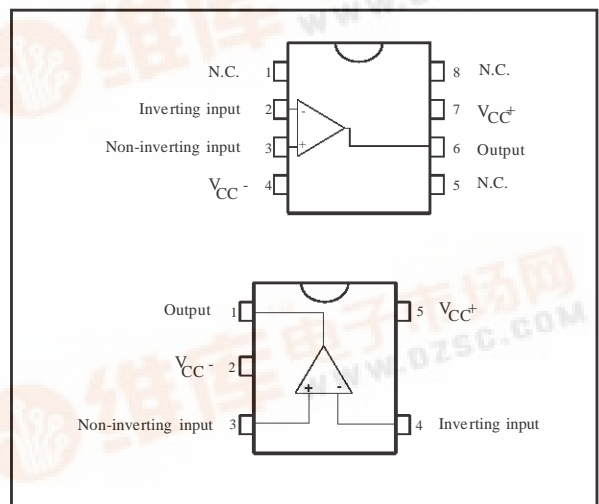

## TS321

### SCHEMATIC DIAGRAM

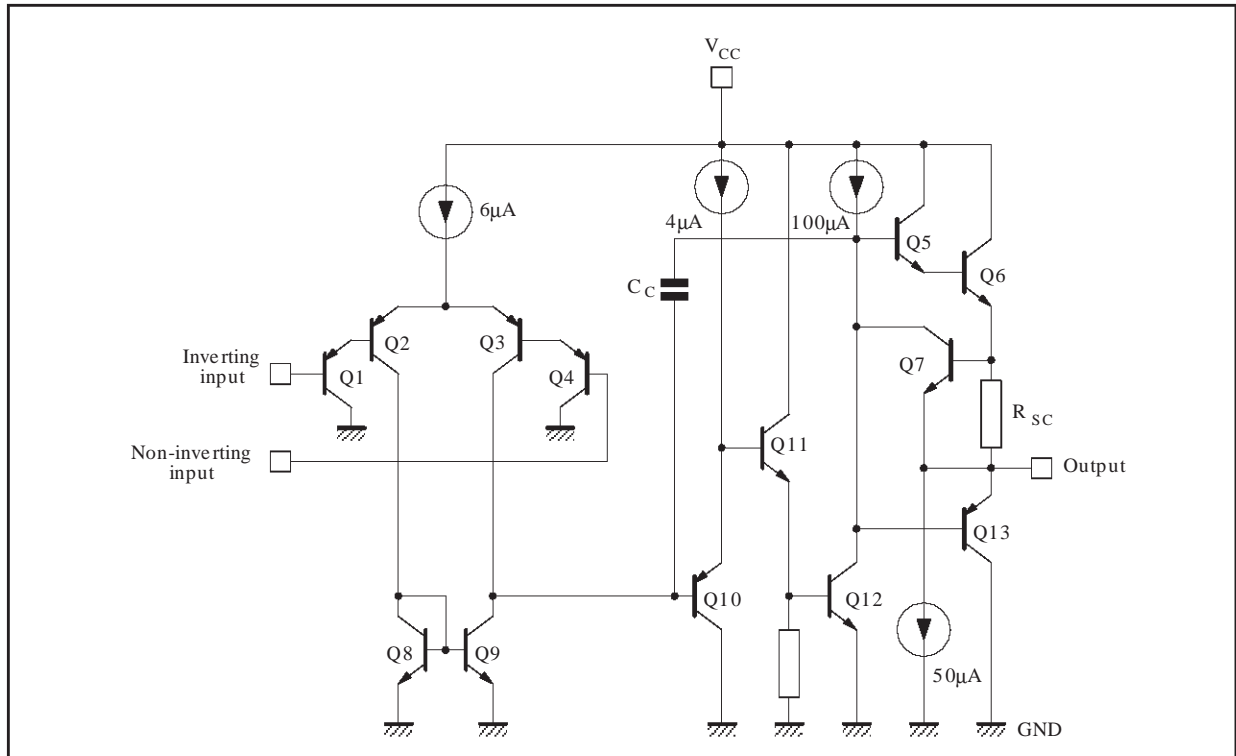

### ABSOLUTE MAXIMUM RATINGS

Symbol	Parameter	Value	Unit
$V_{CC}$	Supply Voltage	$\pm 16$ to 32	V
$V_i$	Input Voltage	-0.3 to +32	V
$V_{id}$	Differential Input Voltage	+32	V
-	Output Short-circuit Duration - note <sup>1)</sup>	Infinite	
$I_{in}$	Input Current - note <sup>2)</sup>	50	mA
$T_{oper}$	Operating Free-air Temperature Range	-40 to +125	°C
$T_{stg}$	Storage Temperature Range	-65 to +150	°C

- Short-circuits from the output to  $V_{CC}$  can cause excessive heating if  $V_{CC} > 15V$ . The maximum output current is approximately 40mA independent of the magnitude of  $V_{CC}$ .
- This input current only exists when the voltage at any of the input leads is driven negative. It is due to the collector-base junction of the input PNP transistor becoming forward biased and thereby acting as input diodes clamps. In addition to this diode action, there is also NPN parasitic action on the IC chip. This transistor action can cause the output voltages of the Op-amps to go to the  $V_{CC}$  voltage level (or to ground for a large overdrive) for the time duration than an input is driven negative. This is not destructive and normal output will set up again for input voltage higher than -0.3V.

**ELECTRICAL CHARACTERISTICS**
 $V_{CC}^+ = +5V$ ,  $V_{CC}^- = \text{Ground}$ ,  $V_o = 1.4V$ ,  $T_{amb} = +25^\circ\text{C}$  (unless otherwise specified)

Symbol	Parameter	Min.	Typ.	Max.	Unit
$V_{io}$	Input Offset Voltage - note <sup>1)</sup> $T_{amb} = +25^\circ\text{C}$ TS321A		0.5	4	mV
	$T_{min.} \leq T_{amb} \leq T_{max.}$ TS321A			2 5 3	
$I_{io}$	Input Offset Current $T_{amb} = +25^\circ\text{C}$ $T_{min.} \leq T_{amb} \leq T_{max.}$		2	30 50	nA
$I_{ib}$	Input Bias Current - note <sup>2)</sup> $T_{amb} = +25^\circ\text{C}$ $T_{min.} \leq T_{amb} \leq T_{max.}$		20	150 200	nA
$A_{vd}$	Large Signal Voltage Gain $V_{CC}^+ = +15V$ , $R_L = 2k\Omega$ , $V_o = 1.4V$ to $11.4V$ $T_{amb} = +25^\circ\text{C}$ $T_{min.} \leq T_{amb} \leq T_{max.}$	50 25	100		V/mV
SVR	Supply Voltage Rejection Ratio ( $R_s \leq 10k\Omega$ ) $V_{CC}^+ = 5$ to $30V$ $T_{amb} = +25^\circ\text{C}$	65	110		dB
$I_{CC}$	Supply Current, no load $T_{amb} = +25^\circ\text{C}$ $T_{min.} \leq T_{amb} \leq T_{max.}$		$V_{CC} = +5V$ 500 $V_{CC} = +30V$ 600 $V_{CC} = +5V$ 600 $V_{CC} = +30$	800 900 900 1000	$\mu\text{A}$
$V_{icm}$	Common Mode Input Voltage Range ( $V_{CC} = +30V$ ) - note <sup>3)</sup> $T_{amb} = +25^\circ\text{C}$ $T_{min.} \leq T_{amb} \leq T_{max.}$	0 0		$V_{CC} - 1.5$ $V_{CC} - 2$	V
CMR	Common Mode Rejection Ratio ( $R_s \leq 10k\Omega$ ) $T_{amb} = +25^\circ\text{C}$	65	85		dB
$I_{source}$	Output Current Source ( $V_{id} = +1V$ ) $V_{CC} = +15V$ , $V_o = +2V$	20	40		mA
$I_{sink}$	Output Sink Current ( $V_{id} = -1V$ ) $V_{CC} = +15V$ , $V_o = +2V$ $V_{CC} = +15V$ , $V_o = +0.2V$	10	20		mA
		12	50		$\mu\text{A}$
$I_o$	Short Circuit to Ground ( $V_{CC} = +15V$ )		40	60	mA
$V_{OH}$	High Level Output Voltage $V_{CC} = +30V$ $T_{amb} = +25^\circ\text{C}$ $T_{min.} \leq T_{amb} \leq T_{max.}$ $R_L = 2k\Omega$	26 25.5	27		V
	$T_{amb} = +25^\circ\text{C}$ $T_{min.} \leq T_{amb} \leq T_{max.}$ $R_L = 10k\Omega$	27 26.5	28		
$V_{OL}$	Low Level Output Voltage $R_L = 10k\Omega$ $T_{amb} = +25^\circ\text{C}$ $T_{min.} \leq T_{amb} \leq T_{max.}$	3.5			mV
		3	5	15 20	
SR	Slew Rate $V_{CC} = +15V$ , $V_i = 0.5$ to $3V$ , $R_L = 2k\Omega$ , $C_L = 100pF$ , $T_{amb} = +25^\circ\text{C}$ , unity gain		0.4		V/ $\mu\text{s}$
GBP	Gain Bandwidth Product $V_{CC} = 30V$ , $f = 100kHz$ , $T_{amb} = +25^\circ\text{C}$ , $V_{in} = 10mV$ , $R_L = 2k\Omega$ , $C_L = 100pF$		0.8		MHz
$\phi_m$	Phase Margin		60		Degrees

# TS321

Symbol	Parameter	Min.	Typ.	Max.	Unit
THD	Total Harmonic Distortion $f = 1\text{kHz}$ , $A_V = 20\text{dB}$ , $R_L = 2\text{k}\Omega$ , $V_o = 2\text{Vpp}$ , $C_L = 100\text{pF}$ , $T_{\text{amb}} = +25^\circ\text{C}$ , $V_{CC} = 30\text{V}$		0.015		%
en	Equivalent Input Noise Voltage $f = 1\text{kHz}$ , $R_s = 100\Omega$ , $V_{CC} = 30\text{V}$		40		$\frac{\text{nV}}{\sqrt{\text{Hz}}}$

- $V_o = 1.4\text{V}$ ,  $R_s = 0\Omega$ ,  $5\text{V} < V_{CC+} < 30\text{V}$ ,  $0 < V_{ic} < V_{CC+} - 1.5\text{V}$
- The direction of the input current is out of the IC. This current is essentially constant, independent of the state of the output so no loading change exists on the input lines.
- The input common-mode voltage of either input signal voltage should not be allowed to go negative by more than 0.3V. The upper end of the common-mode voltage range is  $V_{CC+} - 1.5\text{V}$ , but either or both inputs can go to +32V without damage.

ICC = f(t)

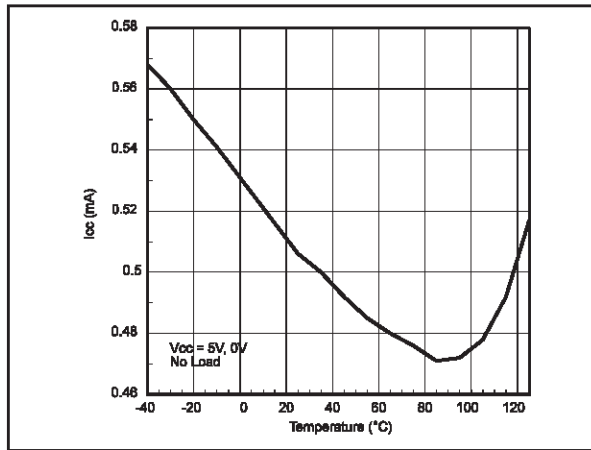

## NON-INVERTING DC GAIN

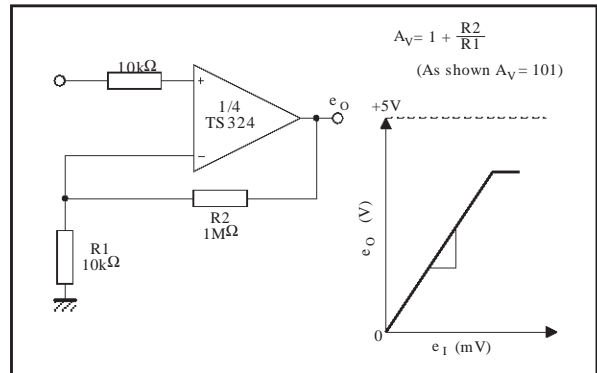

## TYPICAL SINGLE - SUPPLY APPLICATIONS

### AC COUPLED INVERTING AMPLIFIER

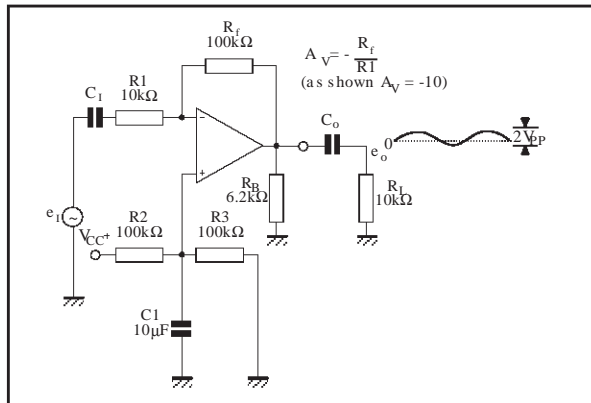

## AC COUPLED NON-INVERTING AMPLIFIER

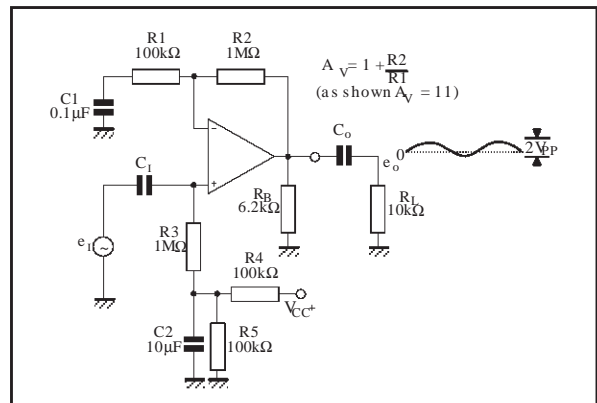

## DC SUMMING AMPLIFIER

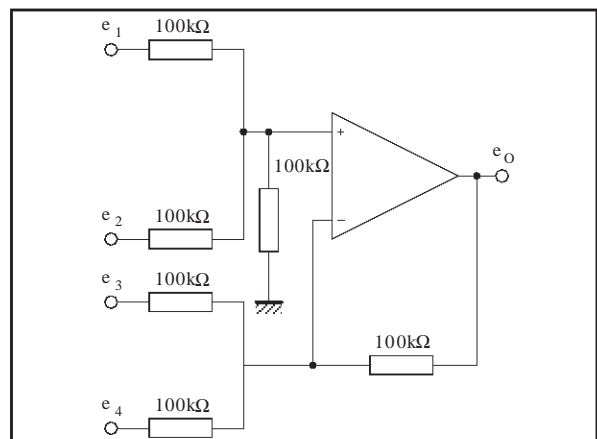

**MACROMODEL**

\*\* Standard Linear Ics Macromodels, 1998.

\*\* CONNECTIONS :

\* 1 INVERTING INPUT

\* 2 NON-INVERTING INPUT

\* 3 OUTPUT

\* 4 POSITIVE POWER SUPPLY

\* 5 NEGATIVE POWER SUPPLY

.SUBCKT TS321 1 3 2 4 5 (analog)

\*\*\*\*\*

.MODEL MDTH D IS=1E-8 KF=3.104131E-15  
CJO=10F

\* INPUT STAGE

CIP 2 5 1.000000E-12

CIN 1 5 1.000000E-12

EIP 10 5 2 5 1

EIN 16 5 1 5 1

RIP 10 11 2.600000E+01

RIN 15 16 2.600000E+01

RIS 11 15 2.003862E+02

DIP 11 12 MDTH 400E-12

DIN 15 14 MDTH 400E-12

VOFP 12 13 DC 0

VOFN 13 14 DC 0

IPOL 13 5 1.000000E-05

CPS 11 15 3.783376E-09

DINN 17 13 MDTH 400E-12

VIN 17 5 0.000000e+00

DINR 15 18 MDTH 400E-12

VIP 4 18 2.000000E+00

FCP 4 5 VOFP 3.400000E+01

FCN 5 4 VOFN 3.400000E+01

FIBP 2 5 VOFN 2.000000E-03

FIBN 5 1 VOFP 2.000000E-03

\* AMPLIFYING STAGE

FIP 5 19 VOFP 3.600000E+02

FIN 5 19 VOFN 3.600000E+02

RG1 19 5 3.652997E+06

RG2 19 4 3.652997E+06

CC 19 5 6.000000E-09

DOPM 19 22 MDTH 400E-12

DONM 21 19 MDTH 400E-12

HOPM 22 28 VOUT 7.500000E+03

VIPM 28 4 1.500000E+02

HONM 21 27 VOUT 7.500000E+03

VINM 5 27 1.500000E+02

EOUT 26 23 19 5 1

VOUT 23 5 0

ROUT 26 3 20

COUT 3 5 1.000000E-12

DOP 19 25 MDTH 400E-12

VOP 4 25 2.242230E+00

DON 24 19 MDTH 400E-12

VON 24 5 7.922301E-01

.ENDS

**ELECTRICAL CHARACTERISTICS**

V<sub>cc</sub> = ±15V, T<sub>amb</sub> = 25°C (unless otherwise specified)

Symbol	Conditions	Value	Unit
V <sub>io</sub>		0	mV
A <sub>vd</sub>	R <sub>L</sub> = 2kΩ	100	V/mV
I <sub>cc</sub>	No load, per operator	300	μA
V <sub>icm</sub>		0 to +3.5	V
V <sub>OH</sub>	R <sub>L</sub> = 2kΩ	+3.5	V
V <sub>OL</sub>	R <sub>L</sub> = 2kΩ	5	mV
I <sub>os</sub>	V <sub>o</sub> = 0V	40	mA
GBP	R <sub>L</sub> = 2kΩ, C <sub>L</sub> = 100pF	0.8	MHz
SR	R <sub>L</sub> = 2kΩ, C <sub>L</sub> = 100pF	0.4	V/μs
∅m	R <sub>L</sub> = 2kΩ, C <sub>L</sub> = 100pF	60	Degrees

## TS321

### PACKAGE MECHANICAL DATA 8 PINS - PLASTIC MICROPACKAGE (SO)

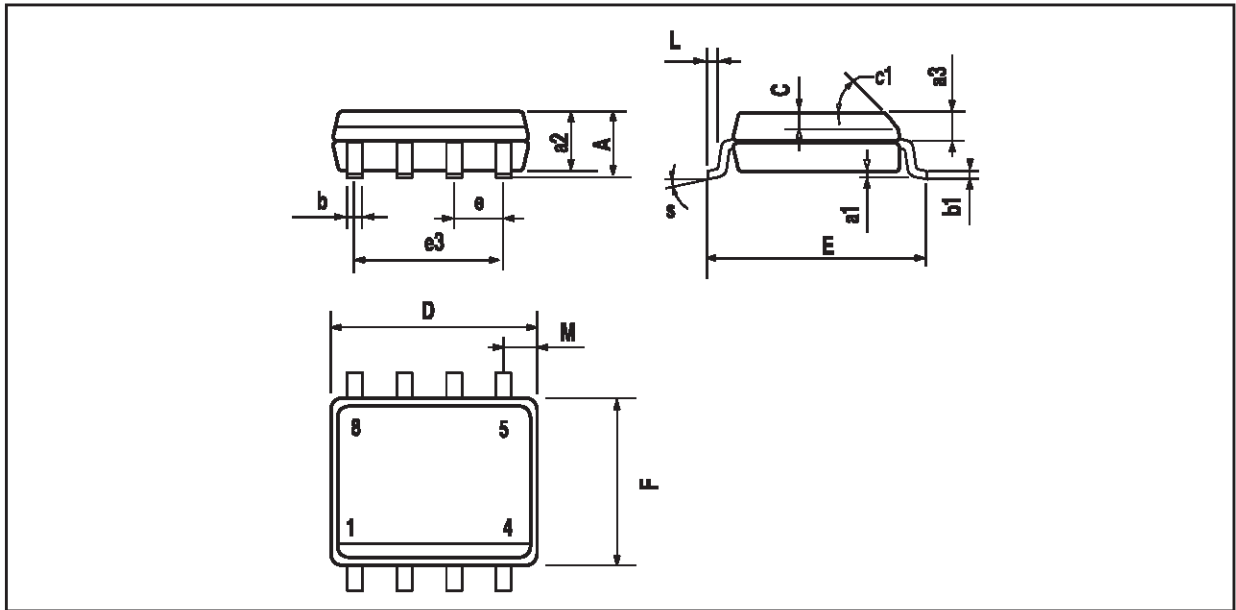

Dim.	Millimeters			Inches		
	Min.	Typ.	Max.	Min.	Typ.	Max.
A			1.75			0.069
a1	0.1		0.25	0.004		0.010
a2			1.65			0.065
a3	0.65		0.85	0.026		0.033
b	0.35		0.48	0.014		0.019
b1	0.19		0.25	0.007		0.010
C	0.25		0.5	0.010		0.020
c1	45° (typ.)					
D	4.8		5.0	0.189		0.197
E	5.8		6.2	0.228		0.244
e		1.27			0.050	
e3		3.81			0.150	
F	3.8		4.0	0.150		0.157
L	0.4		1.27	0.016		0.050
M			0.6			0.024
S	8° (max.)					

**PACKAGE MECHANICAL DATA**  
5 PINS - TINY PACKAGE (SOT23)

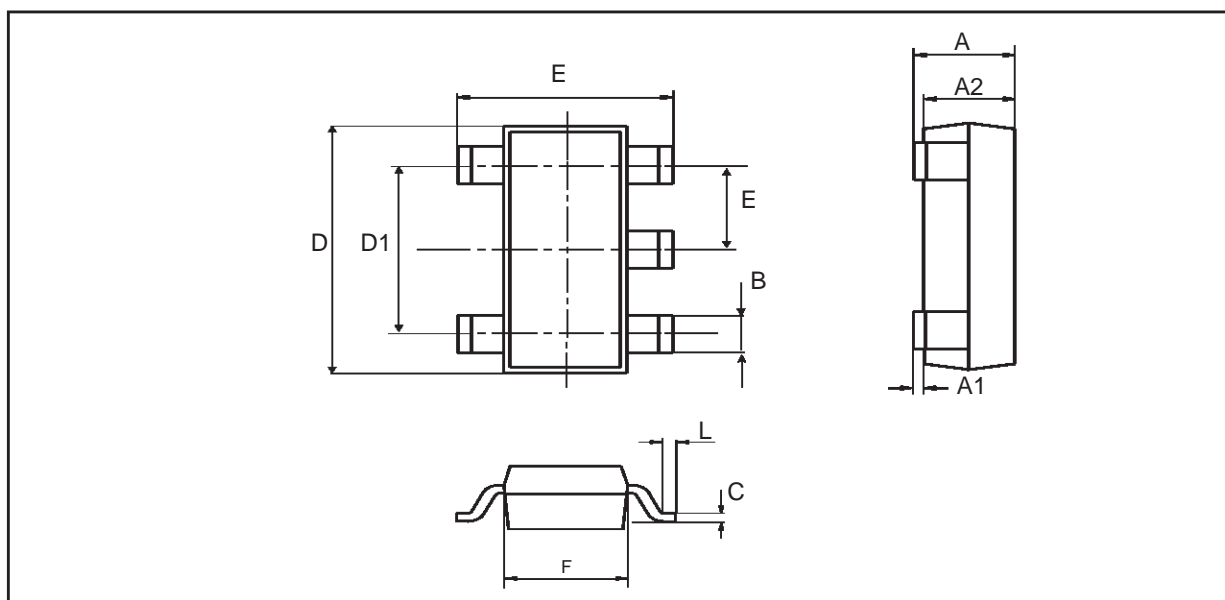

Dim.	Millimeters			Inches		
	Min.	Typ.	Max.	Min.	Typ.	Max.
A	0.90	1.20	1.45	0.035	0.047	0.057
A1	0		0.15			0.006
A2	0.90	1.05	1.30	0.035	0.041	0.051
B	0.35	0.40	0.50	0.014	0.016	0.020
C	0.09	0.15	0.20	0.004	0.006	0.008
D	2.80	2.90	3.00	0.110	0.114	0.118
D1		1.90			0.075	
e		0.95			0.037	
E	2.60	2.80	3.00	0.102	0.110	0.118
F	1.50	1.60	1.75	0.059	0.063	0.069
L	0.10	0.5	0.60	0.004	0.014	0.024
K	0d		10d	0d		10d

Information furnished is believed to be accurate and reliable. However, STMicroelectronics assumes no responsibility for the consequences of use of such information nor for any infringement of patents or other rights of third parties which may result from its use. No license is granted by implication or otherwise under any patent or patent rights of STMicroelectronics. Specifications mentioned in this publication are subject to change without notice. This publication supersedes and replaces all information previously supplied. STMicroelectronics products are not authorized for use as critical components in life support devices or systems without express written approval of STMicroelectronics.

© The ST logo is a registered trademark of STMicroelectronics

© 2001 STMicroelectronics - Printed in Italy - All Rights Reserved  
STMicroelectronics GROUP OF COMPANIES

Australia - Brazil - China - Finland - France - Germany - Hong Kong - India - Italy - Japan - Malaysia - Malta - Morocco  
Singapore - Spain - Sweden - Switzerland - United Kingdom

© <http://www.st.com>