



# TQM 7M5004

## Preliminary Data Sheet

### GSM/EDGE Multi-mode Power Amplifier Module

#### Functional Block Diagram

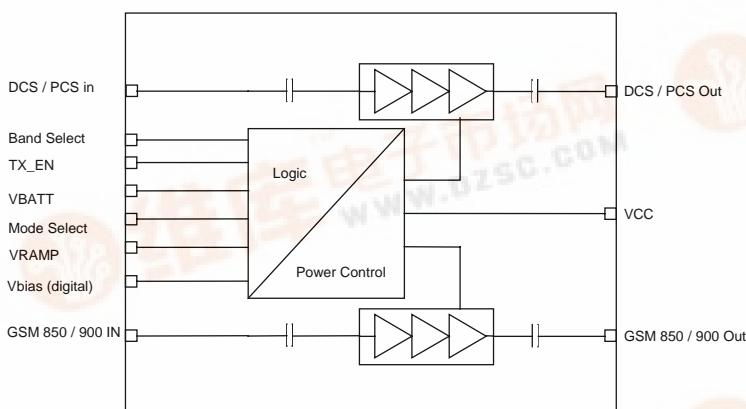

#### Product Description

The TQM 7M5004 is an extremely small (7x7x1.1mm<sup>3</sup>) multi-mode power amplifier module for GSM/EDGE applications. This module has been optimized for high EDGE efficiency and EDGE power class E2 operation while maintaining high GSM/GPRS efficiency. Two EDGE quiescent current states are provided to minimize current consumption during backed-off power settings.

The module incorporates two highly-integrated InGaP power amplifier die with a CMOS controller. The CMOS controller implements a fully integrated closed-loop power control within the module for GSM Operation. This eliminates the need for any external couplers, power detectors, current sensing etc., to assure the output power level. The latter is set directly from the V<sub>ramp</sub> input from the DAC. The module has Tx enable, band select, mode (EDGE or GSM) inputs. Module construction is a low-profile overmolded land-grid array on laminate.

#### Electrical Specifications (Nominal)

Parameter	850 Band			900 Band			DCS / PCS			Units
	Min	Typ	Max	Min	Typ	Max	Min	Typ	Max	
GSM Pout	34.5	35.5		34.5	35.5		32.0	33		dBm
Efficiency	43	50		45	52		40/45	46/50		%
Pin	0	2	4	0	2	4	0	2	4	dBm
EDGE Pout	28.5	29		28.5	29		28	28.5		dBm
Efficiency	20	23		20	23		20	25		%
Gain	29	30.5	32.0	30.0	31.5	33.0	37/36	38/37	40/39	dB
ACPR (400KHz)		-62	-58		-62	-58		-62	-58	dBc

#### Features

- Very compact size – 7x7x1.1 mm<sup>3</sup>.
- High GSM efficiency – GSM 850 50%, GSM900 52%, DCS 46%, PCS 50%
- High EDGE efficiency – GSM 850 23%, GSM 900 23%, DCS 25%, PCS 25%
- Low Quiescent Current Mode for EDGE Pout ≤ 18.5dBm (low-band) & ≤ 18dBm (high-band)
- Positive supply voltage – 3.0 to 4.5 V
- 50 Ω input and output impedances.
- GPRS class 12.
- CMOS band select and internal closed-loop power control for GSM Operation.
- High-reliability InGaP technology.
- Ruggedness 10:1
- No external Vref Required

#### Applications

- GSM/EDGE handsets
- GSM/EDGE wireless cards & data links

#### Package Style

Package Size: LGA 7 x 7 x 1.1 mm

