

The TQ9122 Low-Noise Amplifier is part of TriQuint's RFIC Downconverter Building Block family. Intended for use as the first stage of a Low-Noise Receiver front end, the TQ9122 provides high-performance operation from a standard +5 V power supply. Its low current consumption and small, plastic surface-mount package are well suited for low-cost hand-held and battery-powered applications. The amplifier has internal self-bias circuitry for easy system integration. An external matching network at the input of the amplifier yields optimum noise performance. Output match to 50  $\Omega$  is provided internally for wideband operation. The input pin is DC-blocked.

### Electrical Specifications

**Test Conditions:**  $V_{DD} = +5\text{ V}$ ,  $T_A = 25^\circ\text{C}$ , Frequency 1575 MHz  
with external matching for  $\Gamma_{OPT}$ .

| Parameter <sup>(1)</sup> | Min. | Typ. | Max. | Units |
|--------------------------|------|------|------|-------|
| Frequency of Operation   | 500  |      | 2500 | MHz   |
| Gain                     | 21   | 25   |      | dB    |
| Noise Figure             |      | 1.3  | 1.5  | dB    |
| DC Supply Current        | 14   | 18   | 22   | mA    |

Note: 1. Min/Max values listed are production tested.

## TQ9122

### Low-Noise Amplifier

#### Features

- 500 – 2500 MHz operation
- SO-8 plastic package
- Single + 5 V supply
- Low noise figure  
1.3 dB, typ. @ 1575 MHz
- 25 dB gain @ 1575 MHz
- Output matched to 50  $\Omega$
- 18 mA operating current

#### Applications

- 900 MHz and 2.4 GHz WLAN Receivers
- PCS/PCN Systems
- GPS (Global Positioning Systems)
- Cellular Communications
- Spread-Spectrum Receivers
- Satellite Mobile Terminals

# TQ9122

## Electrical Specifications

Test Conditions:  $V_{DD} = +5\text{ V}$ ,  $T_A = 25^\circ\text{ C}$ , Frequency = 1575 MHz  
with external matching elements tuned for  $\Gamma_{OPT}$ .

| Parameter                    | Conditions           | Min. | Typ. | Max. | Units |
|------------------------------|----------------------|------|------|------|-------|
| Frequency Range              |                      | 500  |      | 2500 | MHz   |
| Gain                         | RF = -40 dBm         | 21   | 25   |      | dB    |
| Noise Figure                 |                      |      | 1.3  | 1.5  | dB    |
| Output 3rd. Order Intercept  | Separation = 500 KHz |      | 0    |      | dBm   |
| Output 1 dB Gain Compression |                      |      | -10  |      | dBm   |
| Output/Input Isolation       |                      |      | 36   |      | dB    |
| Supply Voltage               |                      | 4.5  | 5.0  | 5.5  | V     |
| Supply Current               |                      | 14   | 18   | 22   | mA    |

### Test Circuit

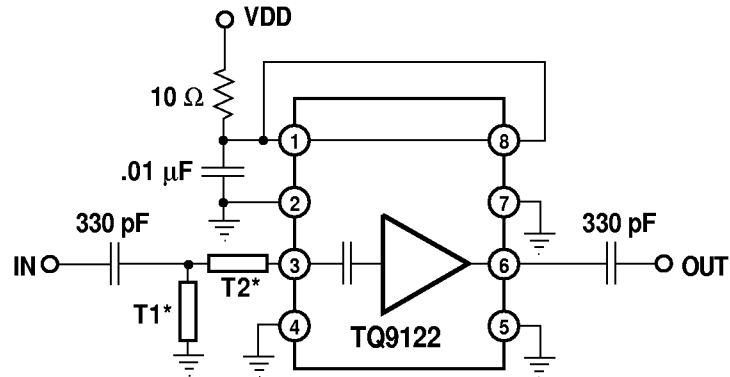

\* 75  $\Omega$  microstrip transmission lines, electrical length as specified in Noise Parameters table

**Typical Performance**  $V_{DD} = +5\text{ V}$ , with external matching elements tuned for  $\Gamma_{OPT}$ .

**Gain vs. Frequency vs. Temperature**

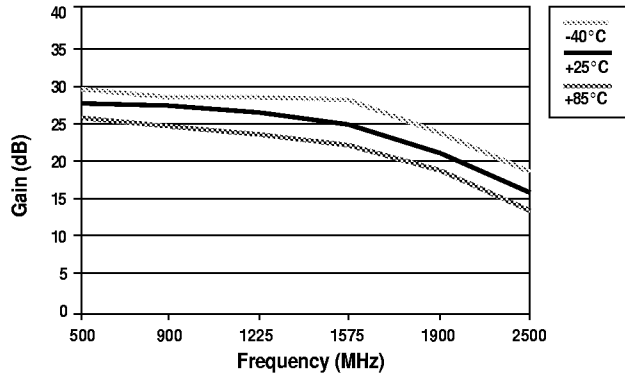

**IP3 vs. Frequency vs. Temperature**

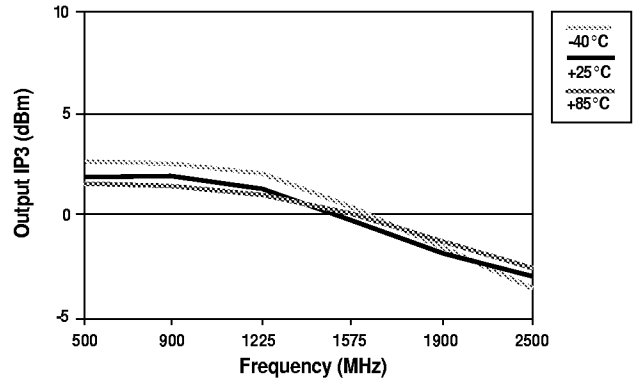

**P1dB vs. Frequency vs. Temperature**

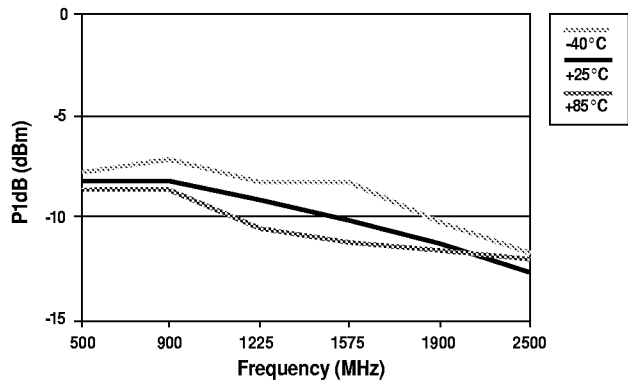

**Noise Figure vs. Frequency vs. Temperature**

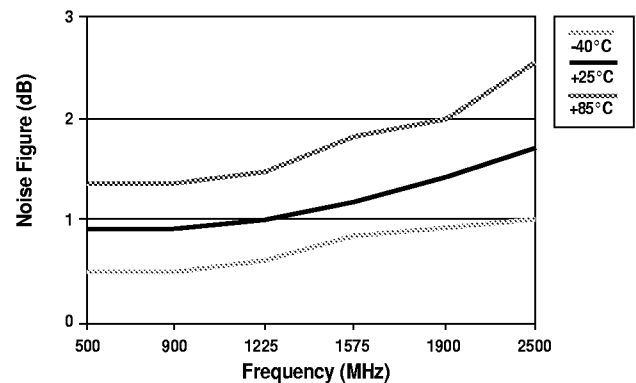

**Isolation vs. Frequency**

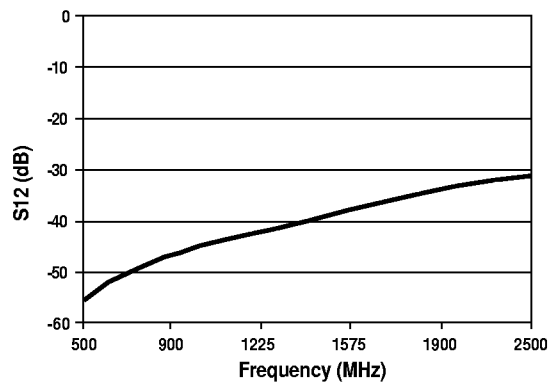

**S22 vs. Frequency**

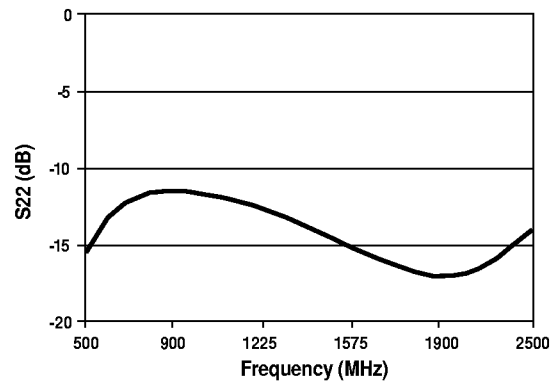

# TQ9122

## Noise Parameters (typical)

| Frequency<br>(MHz) | Noise<br>Figure (dB) | Gamma-Opt |       | R noise<br>(Ohms) | Electrical Length (Z0 = 75Ω) |          |              |          |
|--------------------|----------------------|-----------|-------|-------------------|------------------------------|----------|--------------|----------|
|                    |                      | Mag.      | Angle |                   | T1 (Degrees)                 | (Inches) | T2 (Degrees) | (Inches) |
| 900                | 0.97                 | 0.70      | 23.7  | 29.2              | 34                           | 1.25     | 52           | 1.89     |
| 1225               | 1.21                 | 0.57      | 38.2  | 26.8              | 37                           | 0.99     | 42           | 1.12     |
| 1575               | 1.24                 | 0.56      | 51.4  | 24.5              | 36                           | 0.75     | 33           | 0.69     |
| 1900               | 1.39                 | 0.52      | 68.8  | 20.4              | 33                           | 0.58     | 24           | 0.41     |
| 2500               | 1.82                 | 0.38      | 94.1  | 15.0              | 35                           | 0.45     | 11           | 0.14     |

## S-Parameters (typical)

Test Conditions:  $V_{DD} = +5\text{ V}$ ,  $T_A = 25^\circ\text{C}$ , Reference plane at package leads

| Freq (MHz) | S11  | ∠S11 | S21  | ∠S21 | S12   | ∠S12 | S22  | ∠S22 |
|------------|------|------|------|------|-------|------|------|------|
| 100        | 0.95 | -5   | 14.5 | -157 | 0.000 | 156  | 0.20 | -5   |
| 200        | 0.95 | -9   | 20.1 | -177 | 0.000 | 135  | 0.19 | -9   |
| 300        | 0.94 | -14  | 22.8 | 163  | 0.000 | 134  | 0.17 | -14  |
| 400        | 0.94 | -18  | 23.9 | 144  | 0.000 | 170  | 0.13 | 1    |
| 500        | 0.91 | -23  | 23.5 | 127  | 0.000 | 178  | 0.13 | -116 |
| 600        | 0.89 | -27  | 22.6 | 112  | 0.001 | 162  | 0.13 | -148 |
| 700        | 0.88 | -31  | 21.6 | 97   | 0.001 | 144  | 0.13 | -121 |
| 800        | 0.86 | -36  | 20.5 | 84   | 0.001 | 124  | 0.12 | -114 |
| 900        | 0.85 | -41  | 19.6 | 72   | 0.001 | 107  | 0.10 | -11  |
| 1000       | 0.83 | -46  | 18.6 | 60   | 0.001 | 96   | 0.08 | -13  |
| 1100       | 0.82 | -51  | 17.7 | 48   | 0.001 | 76   | 0.06 | -103 |
| 1200       | 0.80 | -56  | 16.9 | 36   | 0.001 | 56   | 0.05 | 177  |
| 1300       | 0.79 | -60  | 15.9 | 25   | 0.001 | 26   | 0.05 | 163  |
| 1400       | 0.76 | -65  | 15.0 | 13   | 0.001 | 107  | 0.07 | 88   |
| 1500       | 0.75 | -69  | 14.0 | -19  | 0.001 | -26  | 0.08 | 66   |
| 1600       | 0.72 | -74  | 13.1 | -9   | 0.002 | -51  | 0.10 | 68   |
| 1700       | 0.71 | -78  | 12.2 | -20  | 0.002 | -71  | 0.12 | 67   |
| 1800       | 0.69 | -82  | 11.2 | -31  | 0.003 | -86  | 0.14 | 66   |
| 1900       | 0.68 | -86  | 10.4 | -41  | 0.003 | -97  | 0.15 | 65   |
| 2000       | 0.66 | -91  | 9.6  | -51  | 0.004 | -108 | 0.16 | 64   |
| 2100       | 0.65 | -96  | 8.8  | -60  | 0.005 | -116 | 0.17 | 63   |
| 2200       | 0.64 | -100 | 8.1  | -70  | 0.006 | -124 | 0.18 | 63   |
| 2300       | 0.64 | -105 | 7.5  | -79  | 0.008 | -131 | 0.19 | 64   |
| 2400       | 0.63 | -112 | 6.9  | -88  | 0.009 | -138 | 0.20 | 65   |
| 2500       | 0.63 | -117 | 6.4  | -97  | 0.011 | -144 | 0.21 | 66   |

## Gamma Optimum

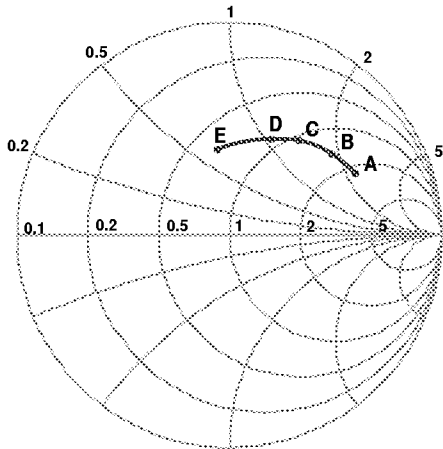

Note: A = 900 MHz, B = 1225 MHz, C = 1575 MHz  
D = 1900 MHz, E = 2500 MHz

## Noise Matching Network

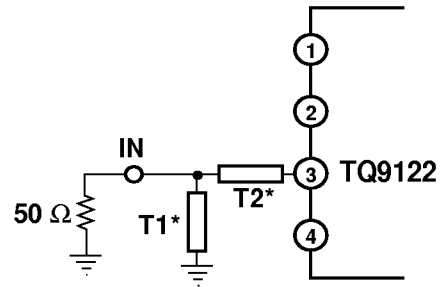

Note: T1 and T2 – Electrical length of 75  $\Omega$  transmission line is given in the Noise Parameters table.

ICs

## Pin Descriptions

| Pin Name        | Pin #      | Description and Usage  |
|-----------------|------------|--|
| V <sub>DD</sub> | 1, 8       | +5 V Power Supply. Decoupled on chip with 50 pF capacitor and 10 $\Omega$ resistor on chip. If additional decoupling is required, decouple with 0.01 uF within 5 mm of package. Pins 1 and 8 are connected internally.                                       |
| IN              | 3          | LNA Input. Internal DC bias and resistor are isolated from the input port. Optimum noise figure requires an external matching network tuned to $\Gamma_{OPT}$ . ESD diode requires the use of a DC-blocking capacitor if DC voltage is present at the input. |
| OUT             | 6          | LNA Output, matched to 50 $\Omega$ . Output must be DC-blocked with capacitor. See note on page 2-35 on use of an external load resistor to increase P1dB and IP3.   |
| GND             | 2, 4, 5, 7 | Ground connection. Keep physically short for stability and performance. Pins are internally connected.   |

## TQ9122 Pinout

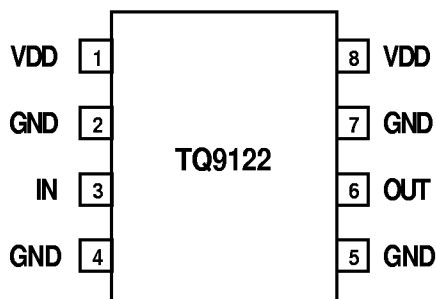

## Simplified Circuit Schematic

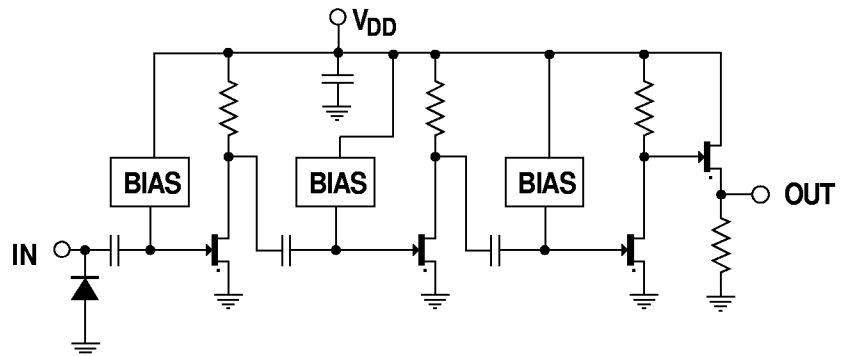

# TQ9122

## General Description

The TQ9122 amplifier circuit is constructed with three gain stages and an output follower, as illustrated in the simplified circuit diagram. The gain stages are cascaded common-source amplifiers which are internally biased to maintain an approximately constant operating current with varying supply voltage. The output is a source-follower stage, and provides a buffered output with an impedance of approximately 75 ohms. The gain of the circuit is broadband over a wide frequency range. However, the application of the part is narrow-band, provided proper impedance matching is employed at the input.

## Power Supply and Ground Connections

The TQ9122 was designed to operate within specifications over the power supply range of 4.5 to 5.5 V, although it will function over a range of 4 to 6 V. The internal biasing maintains a stable operating current with varying supply voltage. The gain, however, will vary slightly with changes in supply voltage.

Internally, the amplifier has 50 pF of capacitance from  $V_{DD}$  to ground for RF decoupling of the supply line. This is usually adequate for testing, but for most system designs, additional

external decoupling should be connected within 5 mm of the package pin. A 10-ohm series resistor in the  $V_{DD}$  line may also be added to provide enhanced stability and some filtering of supply line noise.

Connections to ground must go directly to a low-impedance ground plane. This is critical for maintaining stability. It is therefore recommended that via holes to the ground plane occur within a few millimeters of the package pins.

## RF Input Interfacing, Noise Match

The TQ9122 was designed to operate as a low-noise amplifier. For minimum noise figure, a network providing the optimum noise match impedance (expressed as a reflection coefficient,  $\Gamma_{OPT}$ ) at the input is required, as illustrated below. For maximum gain with slightly degraded noise figure, a conjugate match could be used. Gamma optimum, ( $\Gamma_{OPT}$ ), was determined over the frequency range of the part. Values for selected frequencies are shown in the Noise Parameters Table. The physical realization of gamma optimum is achieved with either microstrip transmission line elements or lumped reactive elements. A transmission line network which provides proper noise matching for this part is the shunt-series combination shown.

### Optimum Noise Match Impedance

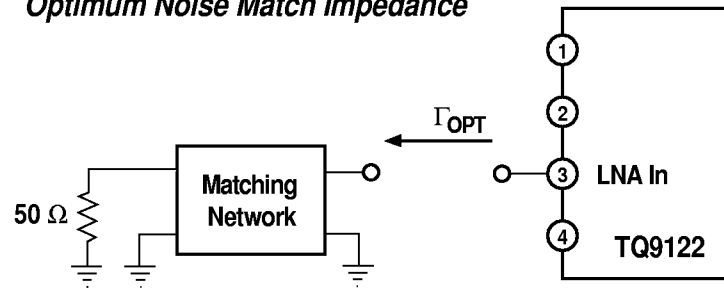

### Possible Matching Networks

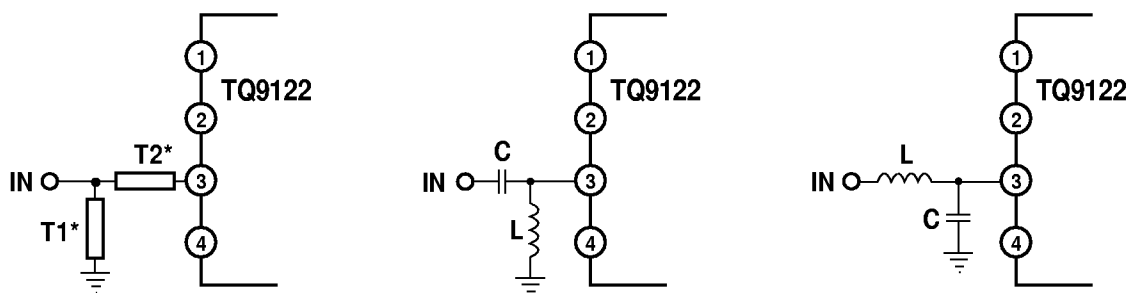

A 75-ohm characteristic impedance is specified for convenient construction with commonly used PC board materials. In principle, any line impedance can work; the critical aspect is establishing the impedance, expressed as  $\Gamma_{OPT}$ . The effective electrical length of the elements T1 and T2 are shown in the Noise Parameter Table, in degrees and inches (free-space length). Simple computation of the physical length is performed by dividing the electrical length by the square root of the effective dielectric constant<sup>1</sup>.

Lumped-element networks which serve as a noise matches are the series C/shunt L and the series L/shunt C circuits.

### RF Output Interfacing

With the output broadband matched to 50 ohms, only a DC blocking capacitor is needed to connect the TQ9122 output to a 50-ohm system, over 500 MHz to 2500 MHz. A suitable

value of capacitor should be chosen to provide the desired high-pass corner frequency (e.g., 100 pF for 31.8 MHz). It is possible to increase the output third order intercept and gain compression point by directly connecting a 470-ohm resistor from the 9122 output to ground, as shown in the application circuit. The IP3 and P1dB are both raised approximately 3 dB with the addition of this resistor. Computation of the exact values necessary to produce  $\Gamma_{OPT}$  at a given frequency is straight forward on a Smith chart. A typical circuit is shown below.

### Application Circuit with Lumped-Element Noise Match and Load Resistor @ 900 MHz

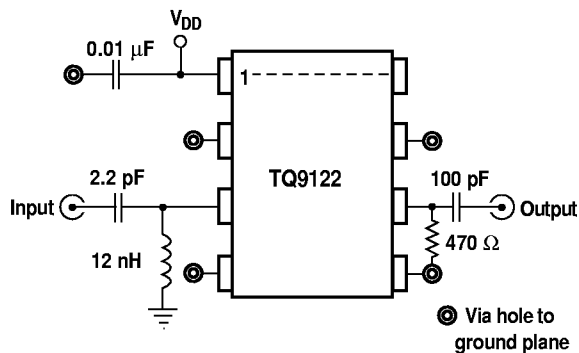

### TQ9122B Evaluation Board Layout

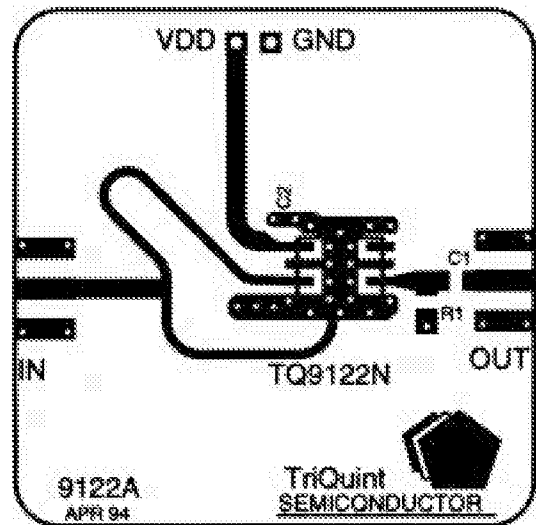

Note: 1. A very useful discussion of this subject is available in Chapter 2, Section 5 of *Microwave Transistor Amplifiers* by Gonzalez. Calculation of the physical length, based on material parameters and noise parameters, is easily handled in "Touchstone" and other modern RF design tools.

# TQ9122

## Absolute Maximum Ratings

| Parameter             | Min. | Typ. | Max. | Units |
|-----------------------|------|------|------|-------|
| DC Power Supply       |      |      | 7.0  | V     |
| Power Dissipation     |      |      | 170  | mW    |
| Input Power           |      |      | +10  | dBm   |
| Storage Temperature   | -55  |      | +150 | °C    |
| Operating Temperature | -40  |      | + 85 | °C    |
| Thermal Resistance    |      |      | 150  | °C/W  |

ESD-sensitive device - Class 1

## SO-8 Plastic Package (N Suffix)

