



**SPECIALTY
COMPONENTS**

Copperhead™ Series CMI Transceiver line interface modules

for SONET/SDH applications
(E4/STM-1 and STM-1)

Compact, one package transceiver line interface modules for interfacing to the most widely used CMI chip sets for E4/STM-1 and STM-1 applications

Features

- Convenient, one package solution replaces several components on pc boards
- Enhanced distance capabilities; excellent signal integrity
- ECL logic interface — directly compatible, completely inter-operable
- Maximum operating distance exceeds 200 meters on 75 ohm RG-6/u and RG-11/u coaxial cable
- Industrial temperature range -40°C to +85°C
- Two models:
 - TM311DVA is compatible with AMCC S3005/S3006 and similar chip sets
 - TM311TRFVA is equipped with G.775 compliant loss-of-signal (LOS) detection circuitry, and is compatible with AMCC S3015/S3016 or S3031B and similar chip sets
- Exceptional return loss ($\geq -15\text{dB}$)
- Low transmit/receive jitter
- Small footprint for surface mounting
- Low power dissipation; 475 mW typical
- Complies with ANSI, Bellcore, and ITU-T/G.703 specifications

Applications

- STM-1 or E4-based transmission systems
- STM-1 or E4 modules
- STM-1 or E4 test equipment
- Compatible with AMCC (S3005/S3006 or S3015/S3016) and other leading STM-1 or E4 chip sets

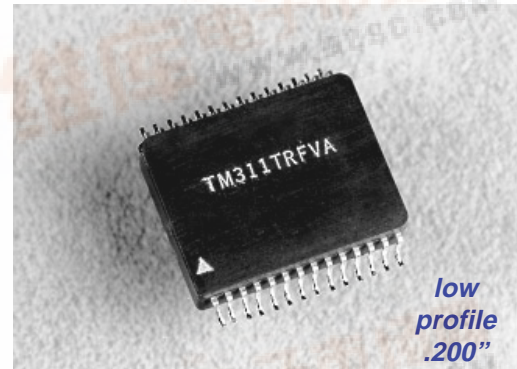

Model TM311TRFVA for AMCC S3015/S3016 or S3031B chip sets. Contains loss-of-signal (LOS) detection circuit.

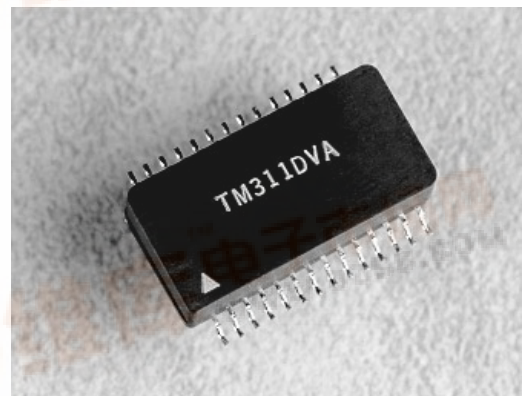

Model TM311DVA for AMCC S3005/S3006 chip sets

Copperhead™ CMI transceiver line interface modules offer a convenient, one package, high performance solution for the complex chip interfacing requirements of CMI applications. The compact packages include transformer coupling for both T_x and R_x functions, an equalizer, a differential amplifier, and buffering for ECL level input and output.

Designed to be inter-operable with existing ECL fibre transceiver drivers, the transceivers meet SONET/ITU-T requirements for coded mark inversion (CMI) data transmission over copper.

The transceivers function equally well in both 311.04 Mb/s SONET STM-1 CMI and 278.528 Mb/s SONET E4 CMI applications, delivering fibre speed data transmission and reception over more than 200 meters of 75 ohm RG-6/u or RG-11/u coaxial cable.

Both Copperhead™ CMI transceiver line interface modules are supplied as surface mount gull wing packages.



BEFORE (unequalized)

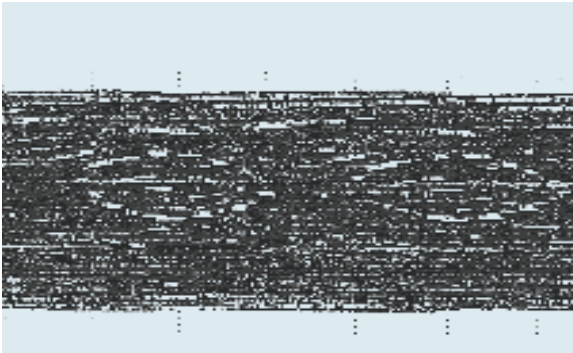

(Figure 1) Actual oscilloscope tracing of 311 Mb/s unequalized input to receiver pins 13 and 14 after transmission over 200 meters of RG-6/u coaxial cable.

AFTER (equalized for CMI)

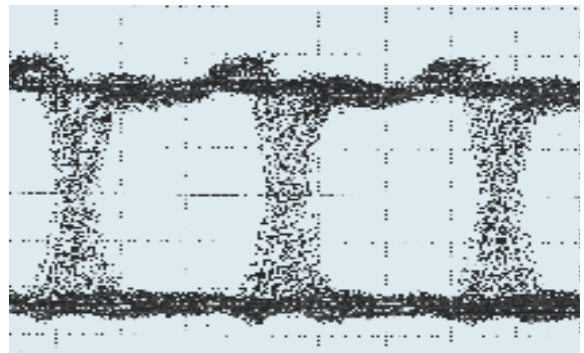

(Figure 2) Tracing of the same signal after equalization. Receiver output measured at pins 2 and 3.

Technical description

Copperhead™ CMI transceiver line interface modules (LIM) take a differential ECL level CMI (coded mark inversion) data signal from the available CMI silicon and convert it to a drive level suitable for transmission over copper cable, and pre-conditioned to meet the G.703 output masks (for binary "ones" and "zeros").

The transceiver LIM matches the impedance of both the ECL circuit and the cable plant, providing a resultant output signal with exceptional return loss. It accomplishes this by utilizing a specially designed wideband pulse transformer, which converts the signal to the appropriate current and voltage levels.

The receiver portion of the transceiver LIM takes the signal from the copper cable, equalizes it using similar impedance matching techniques, and converts the composite signal to ECL level CMI for the mating STM-1 silicon. Signal clarity is much improved over non- interfaced conditions (see figures above).

Benefits of transformer coupling

The pulse transformers used in our Copperhead™ transceiver LIMs provide high isolation and optimum damping of transients. They also eliminate DC components in the signal and provide common mode signal rejection. The transformer is also used to match the load to the source and provide maximum power transfer, and also to prevent reflections from transmission line effects.



Product Qualification Test Outline

I. Subgroup I (all devices - 40 pieces)

Electrical tests at 25°

- Receiver (R_X) tests
 - Jitter (total peak-to-peak)
- Transmit (T_X) tests
 - CMI Mask Test (rise time, fall time, and amplitude)
 - Jitter (total peak-to-peak)
- Total power supply current

II. Subgroup II (4 pieces)

External visual inspection

- Resistance to solvents per MIL-STD-202, Method 215H
 - 1 part isopropyl alcohol, 3 parts mineral spirits
 - Trichloroethane
 - Terpene defluxer with a minimum of 90% d-limonene and 10% surfactant
 - 42 parts water, 1 part propylene glycol monomethyl ether, 1 part monoethanolamine
- Terminal strength per MIL-STD-883, Method 2004.5
 - Lead tension

III. Subgroup III (4 pieces)

Solderability

- Per MIL-STD-202, Method 208, with a 4-hour steam age

IV. Subgroup IV (6 pieces)

Resistance to soldering heat

- Hand solder (2 pieces), solder dip temperature of 430 ±5° C for 3 seconds maximum
- Vapor phase reflow (4 pieces) for a period of 60 seconds at a temperature of 215 +5/-0° C

V. Subgroup V (6 pieces)

Thermal shock

- Per MIL-STD-202, Method 107, Condition A-1, except temperature range shall be -20° C to +125° C, 25 cycles

Vibration

- Per MIL-STD-202, Method 204D, Condition D, 20G peak acceleration, 10 Hz to 2 KHz and return to 10 Hz traversed in 6 minutes

Shock

- Per MIL-STD-202, Method 213B, Condition J, 30G, 11msec shock, 3 shocks in each direction along mutually perpendicular axes

VI. Subgroup VI (6 pieces)

Life Test

- Per MIL-STD-202, Method 108, 1000 hours at a temperature of 75° C

VII. Subgroup VII (8 pieces)

Humidity Test

- Humidity test @ 40° C, and 90% humidity (4 pieces)

VIII. Subgroup VIII (6 pieces)

Electrostatic Discharge, ESD Classification

- The ESD classification to be derived from ESD testing per IEC801-2, EN50082-1, Criteria B

NOTE: There shall be 0 (zero) rejects allowable for each of the subgroups.

EMC Immunity and Radiated Emissions Tests

- EN 55022: (1993) Radio Disturbance CISPR Class A
- IEC 1000-4-2 ESD Test Method
Performance Criteria B, Level 2
- IEC 1000-4-3 Radiated Immunity
Performance Criteria A, Level 3 (10V/m)
- IEC 10004-4 EFT Test Method
Performance Criteria B, Level 3 (at I/O port)

Criteria A: The system shall continue to operate normally. The EUT shall be deemed to have passed the immunity tests if no bit errors occur when receiving data over the cable. Changes of state, reset condition, unrecoverable jab condition, blocked network, or loss of packets is unacceptable.

Criteria B: The system shall operate normally with no data errors through the loop after the test. During the test, data errors, aborted frames and collisions are acceptable. No change of operating state such as system reset or unrecoverable condition is permitted during or after the test.



Table 1

Absolute Maximum Ratings

PARAMETER	SYM	MIN	MAX	UNIT
Storage temperature	T_s	-55	+150	°C
Operating temperature ambient	T_A	-40	+85	°C
Power supply voltage (MECL or PECL)	V_{CC}	-6.0	6.0	V
Power supply current ¹	I_c	-	100	mA
Power dissipation (total)	P_d	-	525	mW
Output current	I_o	-	100	mA
Data input voltage	V_i	0	$V_{CC}+0.5$	V
Differential input voltage	V_d	-	2.40	V
Component body temperature/time	-	-	220/60	°C/s

Note 1: Excluding external pull-down resistors

***Important: This is a hybrid device and is rated for 220°C max for 60 seconds.
Contact factory for recommended solder reflow profile.***

Table 2

General Electrical Parameters

PARAMETER	STM-1	E4/STM-1	UNIT
Data rate	155.52	139.264	Mb/s
Clock rate	311.04	278.528	Mb/s
Tolerance	± 100	± 100	pp m
Operating distance RG-6/u or RG-11/u cable	0 to 200	0 to 200	meters
Cable impedance RG-6/u or RG-11/u cable	75	75	oh ms, no minal



Table 3

Transmitter Electrical Characteristics

V_{CC} = 4.75V to 5.25V

PARAMETER		SYM	MIN	TYPICAL	MAX	UNIT
Input data voltage	Low	V _{IL}	V _{CC} -2.000	V _{CC} -1.750	V _{CC} -1.500	V
	High	V _{IH}	V _{CC} -1.110	V _{CC} -0.880	V _{CC} -0.670	V
Input current	Low	I _{IL}	0.4	-	-	mA
	High	I _{IH}	-	-	0.4	mA
Data rate		DR	139.264	-	155.52	Mb/s
Return loss for 139.264 Mb/s (7MHz to 210MHz)		S ₁₁	-15	-	-	dB
Return loss for 155.51 Mb/s (8MHz to 240MHz)		S ₁₁	-15	-	-	dB
Total peak-peak transmit jitter		T _{PK-PK}	-	50	225	ps

Note: Output of transmitter shall meet the mask requirements of G.703 Figures 24 and 25 (155.52 Mb/s) and Figures 19 and 20 (139.264 Mb/s)

Table 4

Receiver Electrical Characteristics

V_{CC} = 4.75V to 5.25V

PARAMETER		SYM	MIN	TYPICAL	MAX	UNIT
Output data voltage	Low	V _{OL}	V _{CC} -2.000	V _{CC} -1.750	V _{CC} -1.500	V
	High	V _{OH}	V _{CC} -1.110	V _{CC} -0.880	V _{CC} -0.670	V
Data rate		DR	139	-	155	Mb/s
Output rise and fall time (20-80%)		T _R /T _F	0.4	-	1.7	ns
Return loss for 139.264 Mb/s (7MHz to 210MHz)		S ₁₁	-15	-22	-	dB
Return loss for 155.51 Mb/s (8MHz to 240MHz)		S ₁₁	-15	-22	-	dB
Total peak-peak receive jitter (100m RG-6/u)		T _{PK-PK}	-	350	900	ps

Table 5

G.775 Loss of Signal (LOS); applicable to TM311TRFVA only

PARAMETER	MIN	MAX
20 dB flat response 1 MHz to 311.04 MHz Signal detect pin #4 shall be asserted	V _{OH}	V _{CC} -1.110V
35 dB flat response 1 MHz to 311.04 MHz Signal detect pin #4 shall be deasserted	V _{OL}	V _{CC} -1.500V
Attenuation RG-6/u ~ 4 dB/33 meters (100 ft) @ 300 MHz 16 dB ~ 120 meters of RG-6/u (cable loss) ±3 dB margin 19 dB loss budget		



Application example: TM311DVA with AMCC S3005/S3006 chip sets

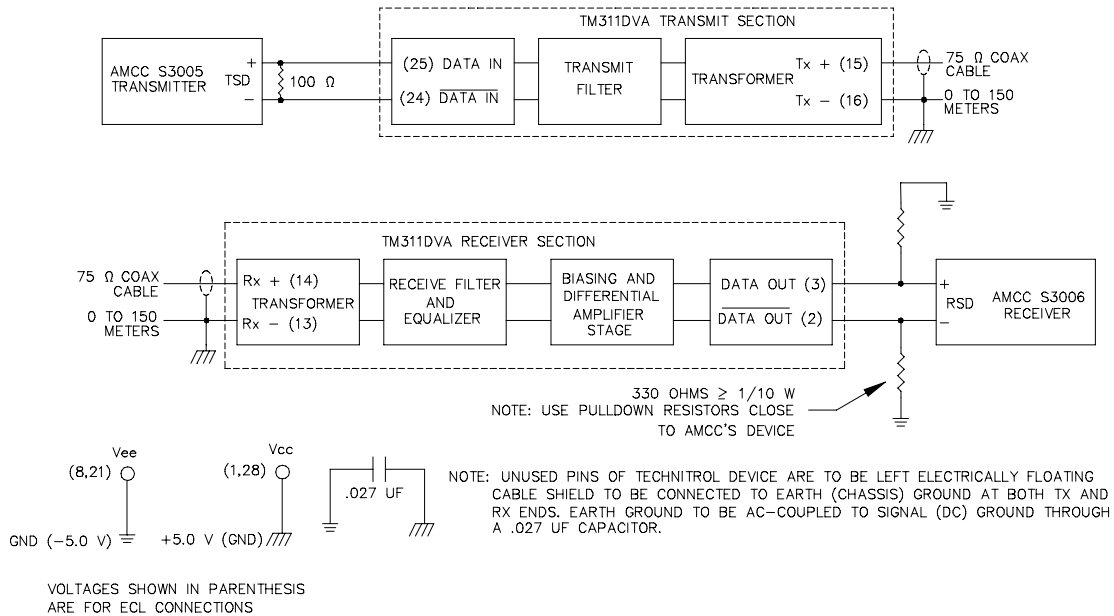

Application example: TM311TRFVA with AMCC S3015/S3016 chip sets

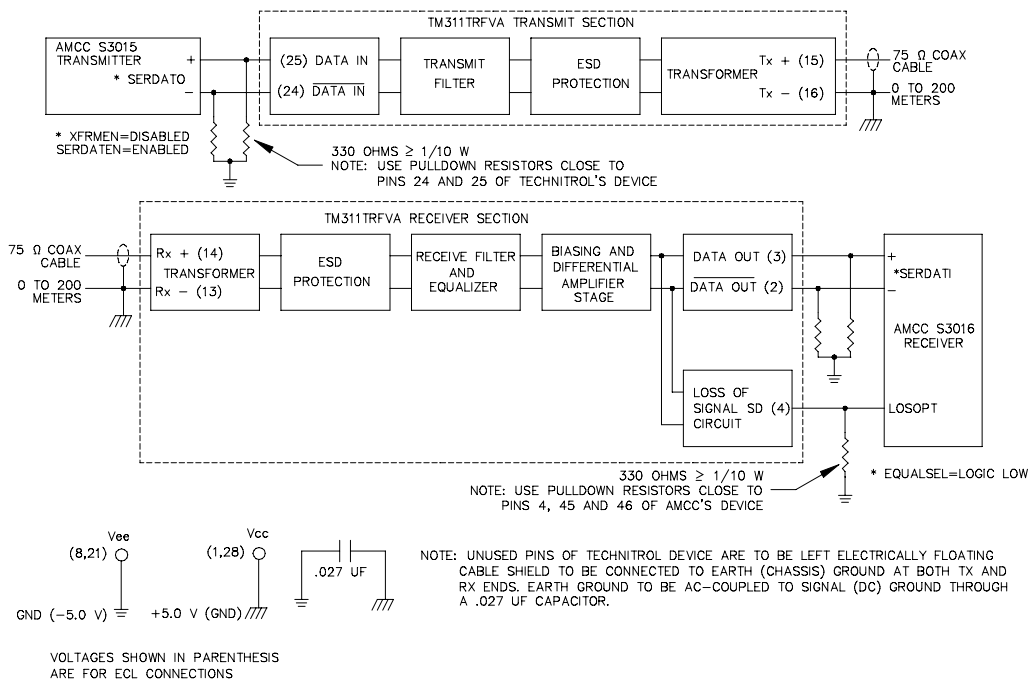



Application example: TM311TRFVA with AMCC S3031B chip

Interface Application Note: For AMCC S3031B and TM311TRFVA

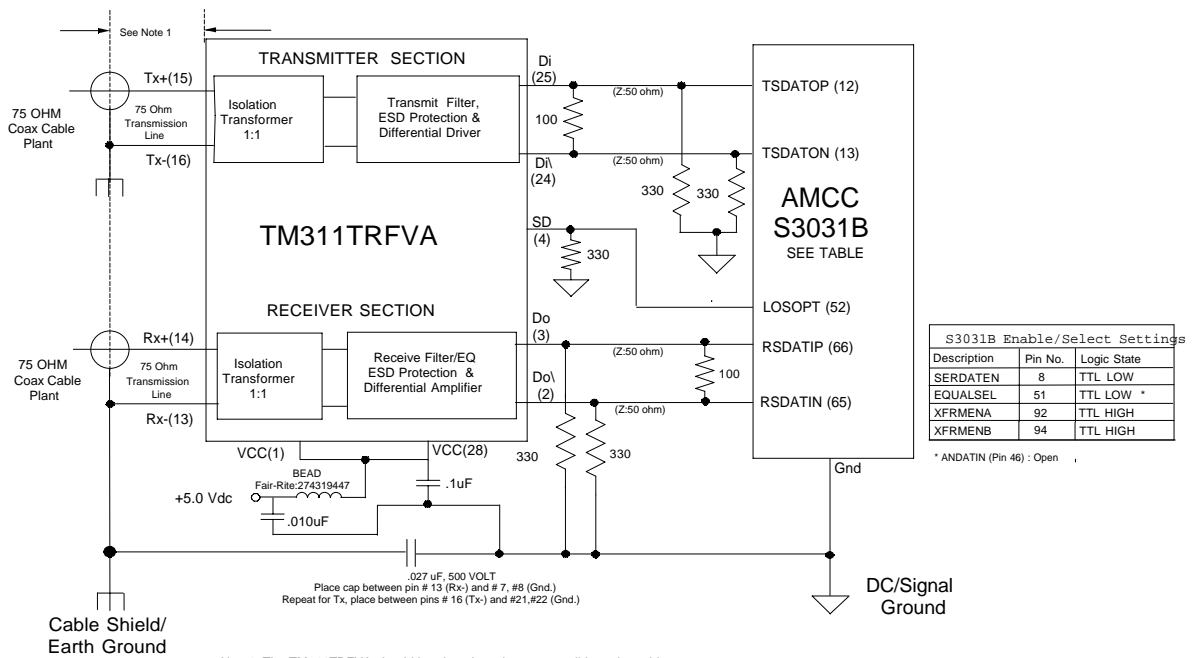

- Note1: The TM311TRFVA should be placed as close as possible to the cable connector, within 0.50" to minimize transmission (strip) line attenuation.
- Note 2: Pins nos. 1 & 28 of TM311TRFVA to be individually AC-coupled to GND with 0.1uF/50V capacitors.
Pin nos. 7,8,21,& 22 to be connected to VEE (GND for PECL).



G.703 Compliant Binary 0 Mask (155.52 Mb/s)

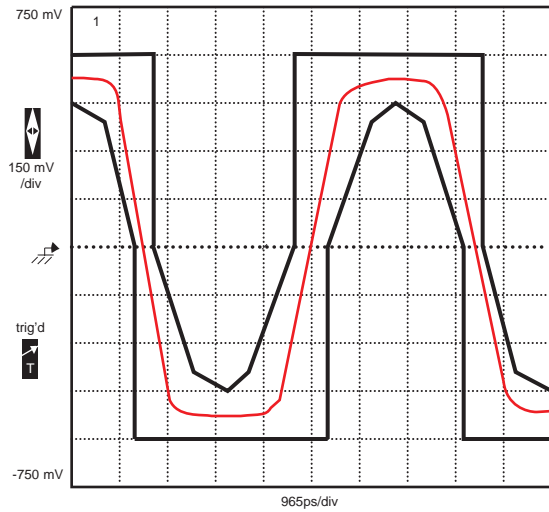

G.703 Compliant Binary 1 Mask (155.52 Mb/s)

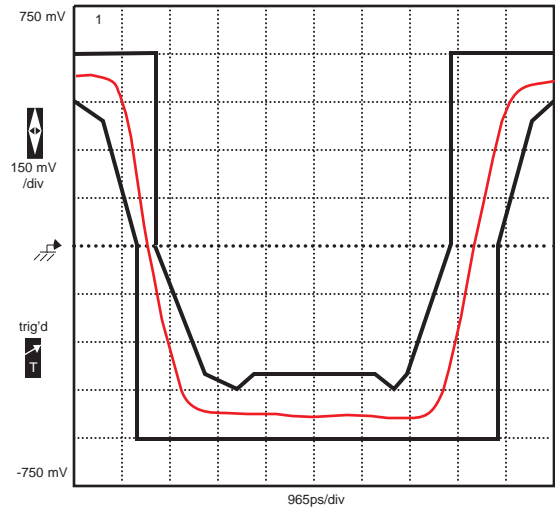

G.703 Compliant Binary 0 Mask (139.264 Mb/s)

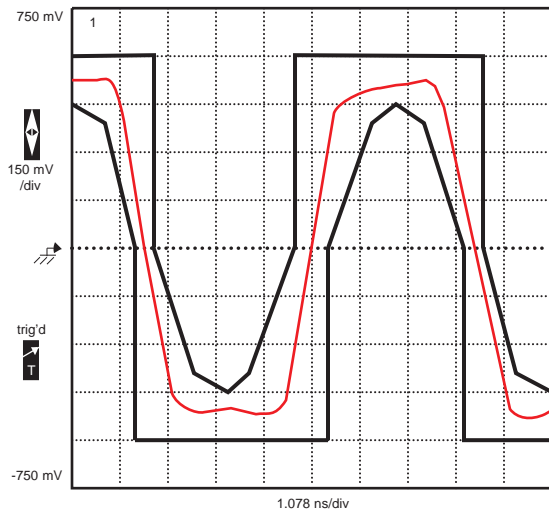

G.703 Compliant Binary 1 Mask (139.264 Mb/s)

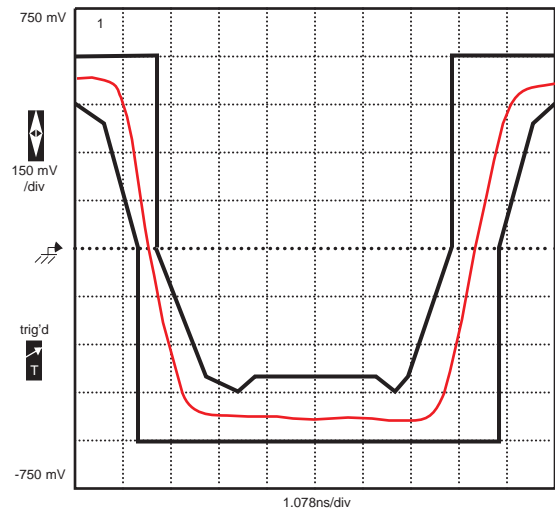



Transceiver Pinouts

Pin number(s)	
1,28	The positive supply of the line interface module. Connect to +5.0V for PECL applications, and to Gnd for ECL applications.
2,3	\overline{D}_O , D_O : Differential ECL data outputs. These outputs can drive 50 ohm loads connected to $V_{CC} - 2.0V$. Recommend 330 ohms to Gnd.
=====	
TM 311TRFVA (with G.775-compliant LOS)	
4	S_D : Single ECL compatible output indicating the state of the electrical input. An ECL HIGH on S_D indicates that the input voltage level is above threshold. Threshold = 20dB flat response 1 to 311.04 MHz.
5	\overline{S}_D : Opposite polarity of Pin #4.
TM 311DVA (without LOS)	
4	No connect.
5	No connect.
=====	
7,8	Gnd (V_{EE}): The negative supply of the line interface module. Connect to Gnd for raised ECL (PECL) applications, and to $-5.2V$ for standard ECL applications.
13,14	R_{X-} , R_{X+} : Transformer coupled differential inputs to receiver section. For coax applications, R_{X-} should be connected to shield of cable/earth Gnd; R_{X+} should be connected to the center conductor. Earth Gnd should be AC coupled to DC signal Gnd using a 0.027 μF capacitor, 500V.
15,16	T_{X+} , T_{X-} : Transformer coupled differential outputs to cable. For coax applications, T_{X-} should be connected to shield of cable/earth Gnd; T_{X+} should be connected to the center conductor. Earth Gnd should be AC coupled to DC signal Gnd using a 0.027 μF capacitor, 500V.
21,22	Gnd (V_{EE}): The negative supply of the line interface module. Connect to Gnd for raised ECL (PECL) applications, and to $-5.2V$ for standard ECL applications.
23	V_{BB} : Is an output pin, which is used for biasing up a threshold reference level, i.e. PECL (3.67V). This pin can only source 1 mA maximum.
24,25	\overline{D}_I , D_I : Differential ECL compatible data inputs to the transmitter side of the module.
6, 9, 10, 11, 12, 17, 18,19, 20, 26, 27	.. These pins are "no connect;" do not apply Gnd, VCC, or signal lines to these pins.

Board Layout Considerations

- 0.1 μF capacitors should be ceramic and placed as close to the VCC pins (1 & 28) of the transceiver as possible.
- Differential lines should be of equal length.
- Data out and signal detect output lines should be as short as possible and isolated from noisy sources.
- Controlled impedance traces from pins 14 (RX+) and 15 (T_{X+}) of the transceiver to the BNCs must be used in order to control return loss.
- A DC signal ground plane should occupy the complete area directly beneath the transceiver from pins 1-12 and 17-28.
- The earth ground plane should occupy the complete area directly beneath pins 13-14 and 15-16.
- There should be a separation of 0.050" between earth and DC ground.
- The earth ground should be AC coupled to DC ground with a 0.027 μF capacitor on both sides of the transceiver (T_X side and R_X side).



Dimensions and transceiver connections: TM311TRFVA

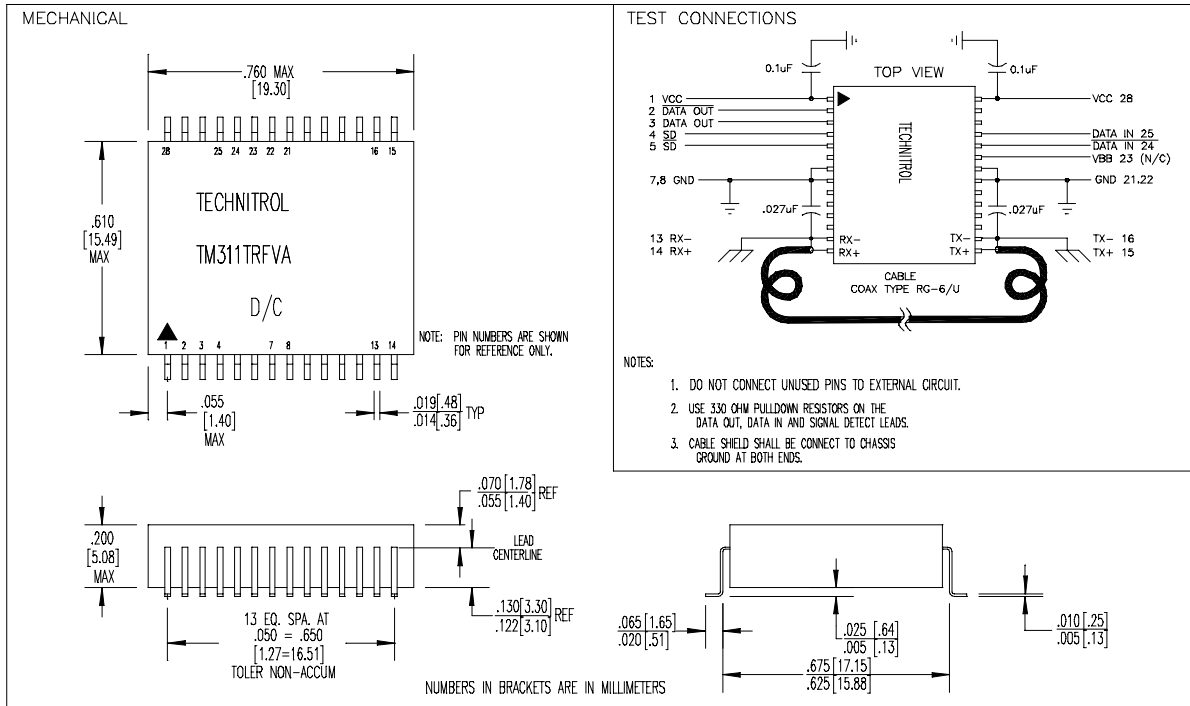

Dimensions and transceiver connections: TM311DVA

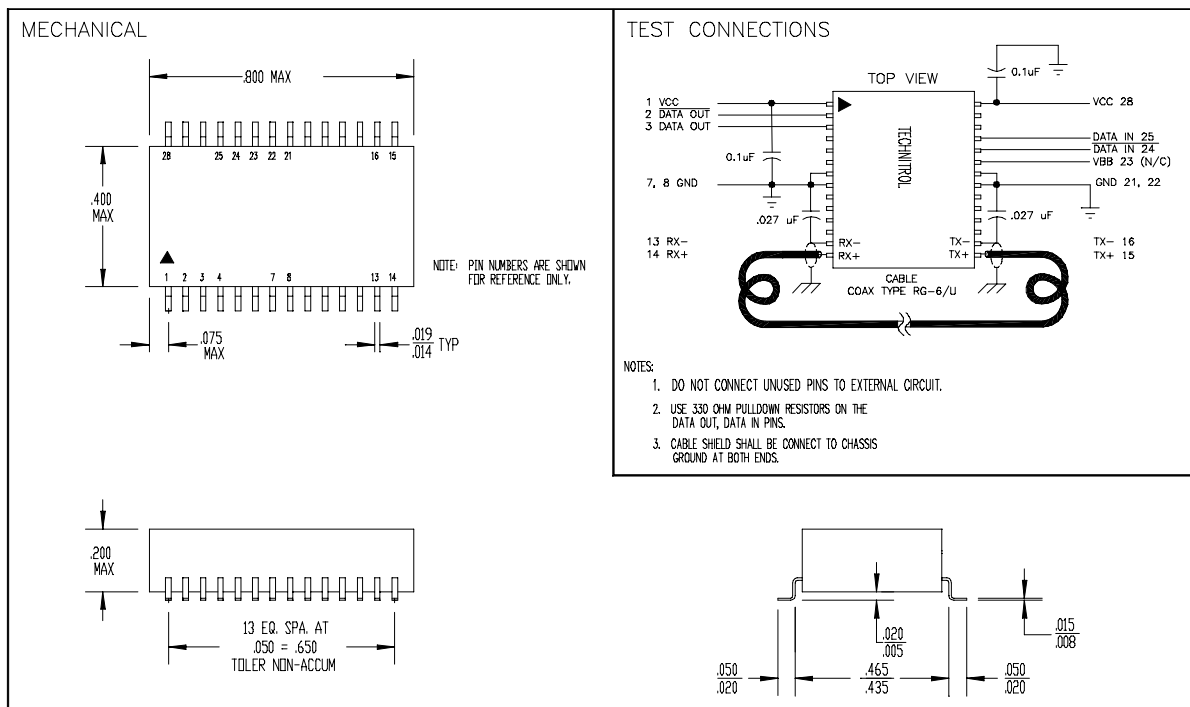



Ordering Information

Available Part Numbers:

TM 311 TR F V A

- A - All 28 pins provided for mounting
- V - Impedance matched for video and mini coax (75 ohm)
- F - Surface mount, gull wing flat package: .610"W x .760"L x .200"H
- TR - G.775 LOS (loss of signal) circuit and transmitter and receiver circuits
- 311 - 311.04 Mb/s SONET STM-1 CMI; also for SONET E4 CMI 278.528 Mb/s
- TM - Line interface module; compact surface-mount package

TM 311 D V A

- A - All 28 pins provided for mounting
- V - Impedance matched for video and mini coax (75 ohm)
- C - Impedance matched for 50 ohm coax
- D - Surface mount, gull wing DIP package: .400"W x .800"L x .200"H
- 311 - 311.04 Mb/s SONET STM-1 CMI; also for SONET E4 CMI 278.528 Mb/s
- TM - Line interface module; compact surface-mount package

Related Products

Series	Features
TM133 Series	132.8125 Mbaud version 1/8 speed Fibre Channel/ATM
TM266 Series	265.625 Mbaud version 1/4 Speed Fibre Channel
TM531 Series	531.25 Mbaud version 1/2 Speed Fibre Channel
TM622 Series	622.08 Mbaud version SONET OC-12, STM-4
TM1062 Series	1.0625 Gbaud version; short haul and long haul models
TM1250 Series	1.250 Gbaud version (Ethernet); short haul and long haul models
T-330SCT	330 Mbaud "HOT LINK"; 265.625 Mbaud version 1/4 speed Fibre Channel Transformer
T-1062SCT	1.0625 Gbaud version full speed Fibre Channel Transformer

WARRANTY

Pulse Specialty Components warrants for a period of 90 days from the date of shipment, that under normal use and service, its products will be free from defects in workmanship and material. Pulse Specialty Components' sole responsibility under this warranty is, at its option, to repair or replace, without charge, any defective product or part, or to credit buyer for the purchase price of such defective product, provided:

- 1) Buyer promptly notifies Pulse Specialty Components in writing within the warranty period, and
- 2) The defective product or part is returned to Pulse Specialty Components with transportation charges prepaid by Buyer, and
- 3) Pulse Specialty Components examination of such product shall disclose to its satisfaction that said defect exists and has not been caused by misuse, neglect, improper installation, repair or alteration, or accident.

EXCEPT FOR THE ABOVE WARRANTY AND THE IMPLIED WARRANTY OF TITLE, PULSE SPECIALTY COMPONENTS MAKES NO OTHER WARRANTIES, EXPRESS OR IMPLIED, INCLUDING ANY IMPLIED WARRANTY OF MERCHANTABILITY OR FITNESS FOR ANY PARTICULAR PURPOSE. NO LIABILITY IS ASSUMED FOR EXPENDABLE ITEMS SUCH AS LAMPS AND FUSES. PULSE SPECIALTY COMPONENTS WILL NOT BE LIABLE FOR INCIDENTAL OR CONSEQUENTIAL DAMAGES UNDER ANY CIRCUMSTANCES.



**SPECIALTY
COMPONENTS**