

**Lucent Technologies**  
Bell Labs Innovations



## T7531A/T7536 16-Channel Programmable Codec Chip Set

### Features

- Single 5 V power supply operation
- Per-channel programmable transmit gain  
— 19.4 dB range, better than 0.01 dB steps
- Per-channel programmable receive gain  
— 25.4 dB range, better than 0.01 dB steps
- Per-channel programmable internal balance networks
- Programmable termination impedances
- Per-channel programmable  $\mu$ -law, A-law, or linear PCM output
- Automatic gain calibration
- Advanced board- and self-test capability
- Programmable time-slot assignment
- Data rate of 2.048 MHz or 4.096 MHz
- Differential transmit amplifiers
- Single-ended or differential receive amplifiers
- Analog and digital loopbacks
- Sigma-delta converters with dither noise reduction

- Serial microcontroller control interface
- JTAG test port

### General Description

The T7531A is a custom, 16-channel line card signal processor which, together with a pair of custom T7536 octal A/D and D/A converters, comprises a low-cost, highly programmable voice codec that is compatible with all worldwide POTS lines.

Transmit and receive gains and hybrid balance coefficients are programmable per channel. Termination impedance is programmable per chip set. These functions, as well as time-slot assignment, calibration, and board test, are controlled via a microcontroller interface.

The DSP engine in the T7531A can be used to test the line card. When voice processing is not required, the spare processing time can be allocated on a per-line basis to a suite of user-controlled board-test routines. Providing intelligent board-test functionality at the line-card level frees the switch from having to perform test and error diagnosis tasks.

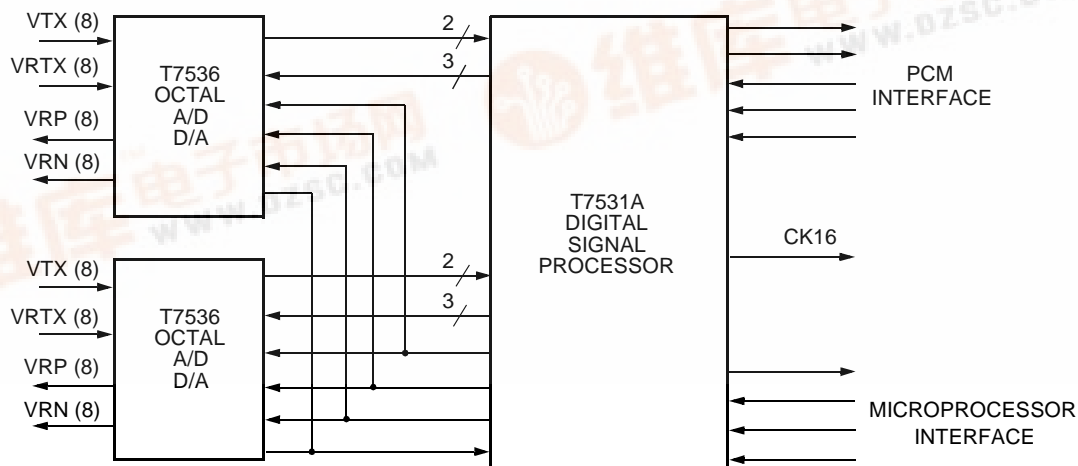

Figure 1. System Block Diagram



**Table of Contents**

<b>Contents</b>	<b>Page</b>	<b>Figures</b>	<b>Page</b>
Features .....	1	Figure 1. System Block Diagram .....	1
General Description .....	1	Figure 2. Block Diagram of T7536 Octal Converter ....	4
T7536 Description .....	4	Figure 3. Block Diagram of One T7536 Analog	
T7531A Description .....	5	Channel .....	4
Pin Information .....	7	Figure 4. T7531A Block Diagram .....	5
Chip Set Functional Description .....	12	Figure 5. T7531A Digital ac Path .....	6
Transmit Path.....	12	Figure 6. Control, PCM, and Octal Interfaces .....	6
Receive Path.....	13	Figure 7. T7536 68-Pin PLCC .....	7
Other Chip Set Functions.....	13	Figure 8. T7531A 68-Pin PLCC .....	8
T7531A Functional Blocks .....	14	Figure 9. Timing Characteristics of PCM Interface	
DSP Engine Timing.....	16	Assuming 2.048 MHz SCK Rate .....	30
T7531A Program Structure .....	16	Figure 10. Timing Diagram for Microprocessor	
Control of the DSP Engine via the Microprocessor		Write/Read to/from the DSP on the	
Interface .....	17	Control Interface .....	31
The DSP Engine Time-Slot Information Tables ....	17	Figure 11. 16-Channel Line Card Solution .....	42
The DSP Engine ac Path Coefficient Table .....	17		
The Time-Slot Control Word .....	18		
Operations Performed by the DSP Engine at			
T7531A Start-Up .....	18		
Microprocessor Start-Up of the DSP Engine .....	19		
Powering Up a Time Slot in the T7531A.....	19		
Disabling a Time Slot in the T7531A.....	19		
T7536 Powerup/Powerdown.....	19		
Changing DSP RAM Space of an Active Time			
Slot .....	20		
DSP Engine Memory Requirements .....	20		
T7531A Reset and Start-Up.....	20		
Hardware Reset .....	20		
Internal Reset.....	21		
Reset of the T7536 Devices.....	21		
Start-Up After Internal Reset.....	21		
Autocalibration .....	22		
User Test Features .....	22		
Self-Test and Board-Test Routines.....	22		
Handling Precautions .....	23		
Absolute Maximum Ratings.....	23		
Electrical Characteristics .....	24		
dc Characteristics .....	24		
Transmission Characteristics .....	25		
Timing Characteristics .....	29		
Software Interface .....	32		
Applications .....	42		
Outline Diagram.....	43		
68-Pin PLCC .....	43		
Ordering Information.....	44		

## Table of Contents

Tables	Page
Table 1. T7536 Pin Descriptions .....	9
Table 2. T7531A Pin Descriptions .....	10
Table 3. Active Time-Slot Spacing in a PCM Bus Frame .....	15
Table 4. DSP Engine RAM Map for Channel_0 ac Path Coefficients .....	17
Table 5A. Bit Maps for DSP Engine Time-Slot Control Word .....	18
Table 5B. Bit Map for Default Per-Board Coefficient Tables .....	18
Table 6. DSP Engine RAM Map for Time-Slot Information Table 0 .....	18
Table 7. Summary of Microprocessor Commands for Control of T7531A Data Processing .....	20
Table 8. Digital Interface .....	24
Table 9. Analog Interface .....	24
Table 10. T7536 Power Dissipation .....	25
Table 11. T7531A Power Dissipation .....	25
Table 12. Gain and Dynamic Range .....	25
Table 13. Noise (per Channel) .....	27
Table 14. Distortion and Group Delay .....	28
Table 15. Crosstalk .....	28
Table 16. PCM Interface Timing .....	29
Table 17. Serial Control Port Timing .....	31
Table 18. DSP Engine RAM Memory Map .....	32
Table 19. T7531A Time-Slot Assignment Memory Map .....	34
Table 20A. Bit Map for T7531A Time-Slot Assignment Registers at 0x1400—0x140F .....	34
Table 20B. Bit Map for CTZ Disable and Null Channel .....	34
Table 21. T7531A Channel Register Memory Map for T7536 Device 0 .....	35
Table 22. T7531A Channel Register Memory Map for T7536 Device 1 .....	35
Table 23. Bit Map for T7536 Powerup/Powerdown Registers at 0x1500—0x1507 and 0x1540—0x1547 .....	35
Table 24. Bit Map for T7536 Channel Control Register 1 at 0x1508—0x150F and 0x1548—0x154F .....	36
Table 25. T7536 Control Register 1: Transmit Gain .....	36
Table 26. T7536 Control Register 1: Analog Termination Impedance .....	36
Table 27. T7536 Control Register 1: Digital Loopback .....	37
Table 28. Bit Map for T7536 All Channel Test Register at 0x1510 and 0x1550 .....	37
Table 29. Bits 3:0 of T7536 All Channel Test Register at 0x1510 and 0x1550 .....	37
Table 30. Bit Map for T7536 Channel Control Register 2 at 0x1518—0x151F and 0x1558—0x155F .....	38
Table 31. T7536 Control Register 2: Receive Gain .....	38
Table 32. T7531A Control Register Map .....	38
Table 33. Bits 15:8 of T7531A Board Control Word 1 at 0x1FFE .....	39
Table 34. Bits 7:0 of T7531A Board Control Word 1 at 0x1FFE .....	39
Table 35. Bits 15:9 of T7531A Board Control Word 2 at 0x1FFC .....	40
Table 36. Bits 8:0 of T7531A Board Control Word 2 at 0x1FFC .....	40
Table 37. Bits 15:0 of T7531A Board Control Word 3 at 0x1FFA .....	40
Table 38. Bits 15:0 of T7531A Board Control Word 4 at 0x1FF8 .....	40
Table 39. Bits 15:0 of T7531A Board Control Word 5 at 0x1FF6 .....	40
Table 40. Bits 15:0 of T7531A Reset of Microprocessor Commands at 0x7FFF .....	40
Table 41. DSP Engine ROM Memory Map .....	41

General Description (continued)

T7536 Description

The T7536 block diagram is shown in Figure 2. Each of its eight channels consists of an antialias filter, sigma-delta A/D and D/A converters, reconstruction and smoothing filters, termination impedance synthesis, and selectable gain. The digital oversampled data is multiplexed onto a serial data port designed to interface with the T7531A. Another serial interface accepts control data from the T7531A for activating the various gain settings, self-test, and powerdown modes. This chip also contains a precision voltage reference. It is packaged in a 68-pin PLCC.

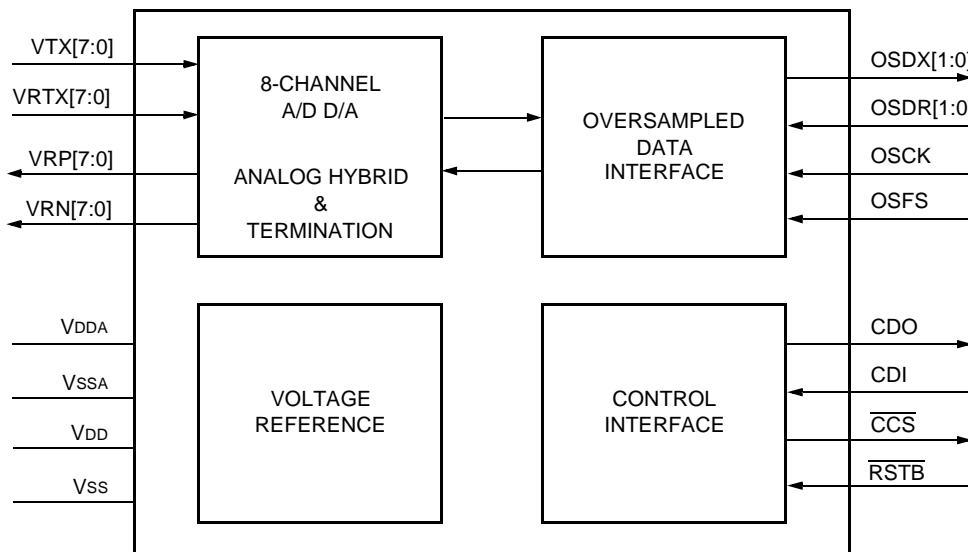

5-3794.b (F)

Figure 2. Block Diagram of T7536 Octal Converter

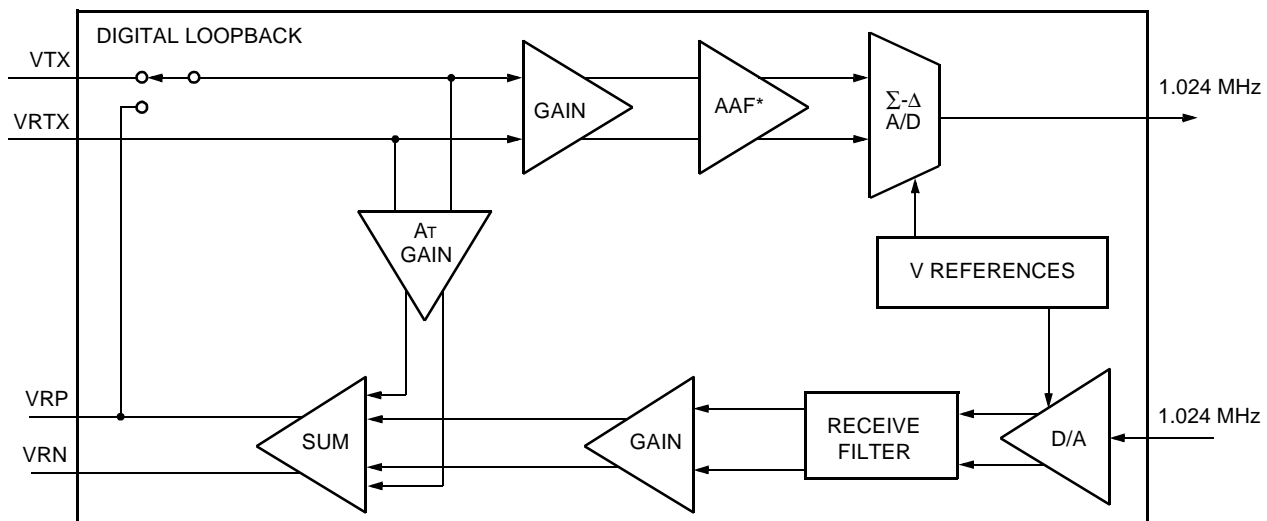

5-3796.d (F)

\* Antialiasing filter.

Figure 3. Block Diagram of One T7536 Analog Channel

**General Description** (continued)

**T7531A Description**

As shown in Figure 4, the T7531A contains a digital signal processor (DSP) engine surrounded by a customized input/output frame. The I/O frame performs the  $\mu$ -law or A-law conversion as well as the decimation and interpolation functions needed to interface the sigma-delta bit streams to the digital signal processor engine. The sigma-delta converters operate at a 1.024 MHz sample rate, while the signal processor operates at 16 ksamples/s. A key function of the I/O frame is to control the timing of the digital data going to the signal processor so that group delay is minimized.

The I/O frame also contains an integrated phase-locked loop which synthesizes all the required internal clocks for the chip set.

The microcontroller interface is used to download the gain and balance network settings, powerup/powerdown commands, time-slot assignments, digital loopback settings, and commands for the T7536 octal chips. This chip is packaged in a 68-pin PLCC.

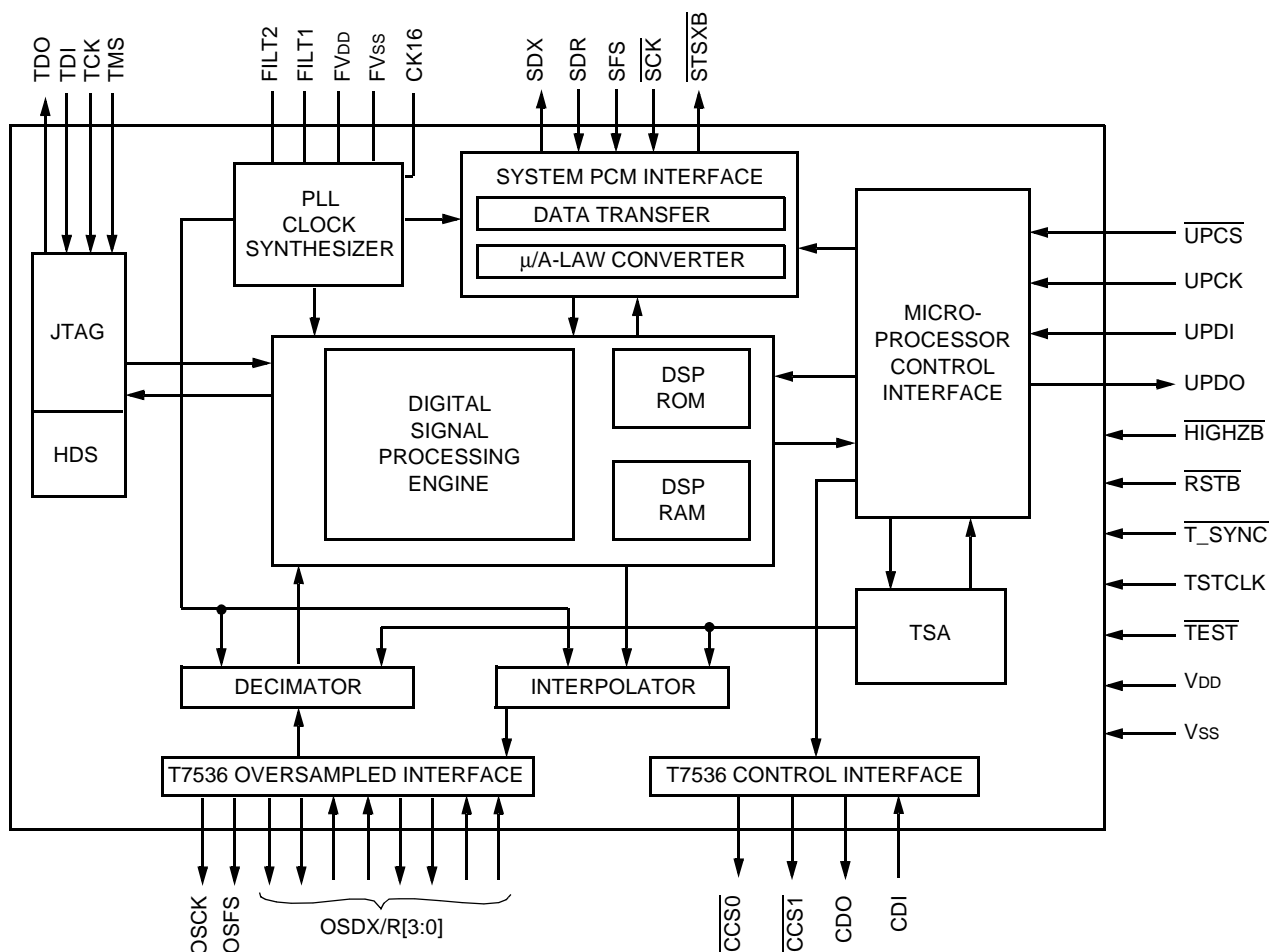

5-3795.c (F)03

**Figure 4. T7531A Block Diagram**

General Description (continued)

T7531A Description (continued)

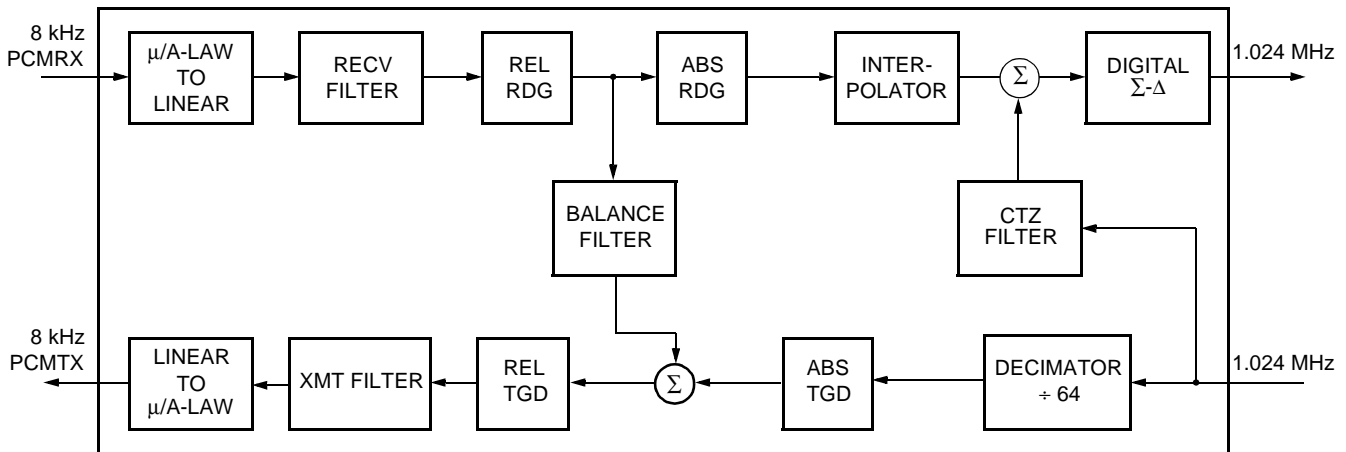

5-3797.b (F)

Figure 5. T7531A Digital ac Path

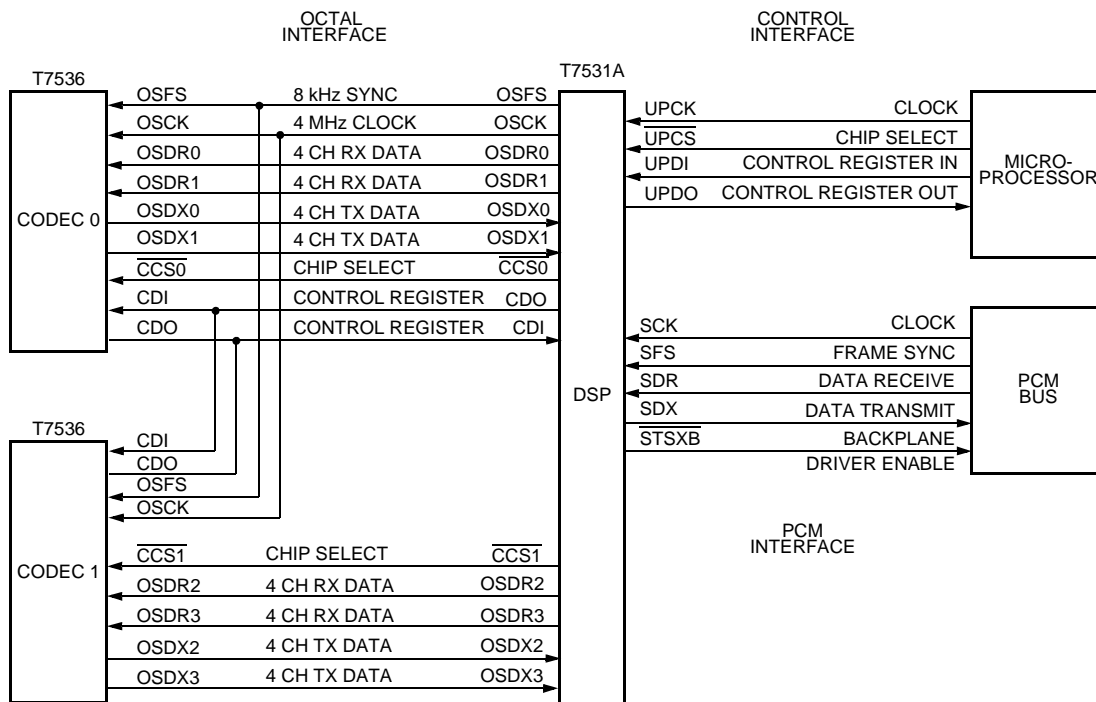

5-4229.b (F)

Figure 6. Control, PCM, and Octal Interfaces

Pin Information

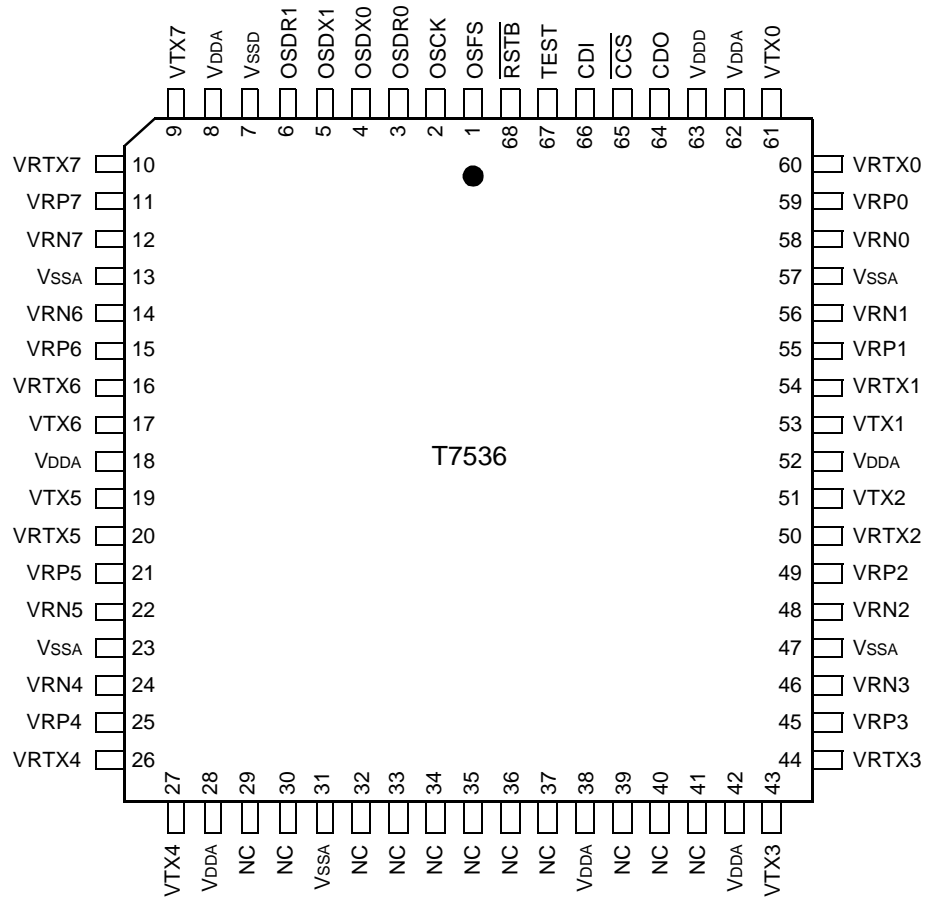

5-4230.b (F)

Figure 7. T7536 68-Pin PLCC

Pin Information (continued)

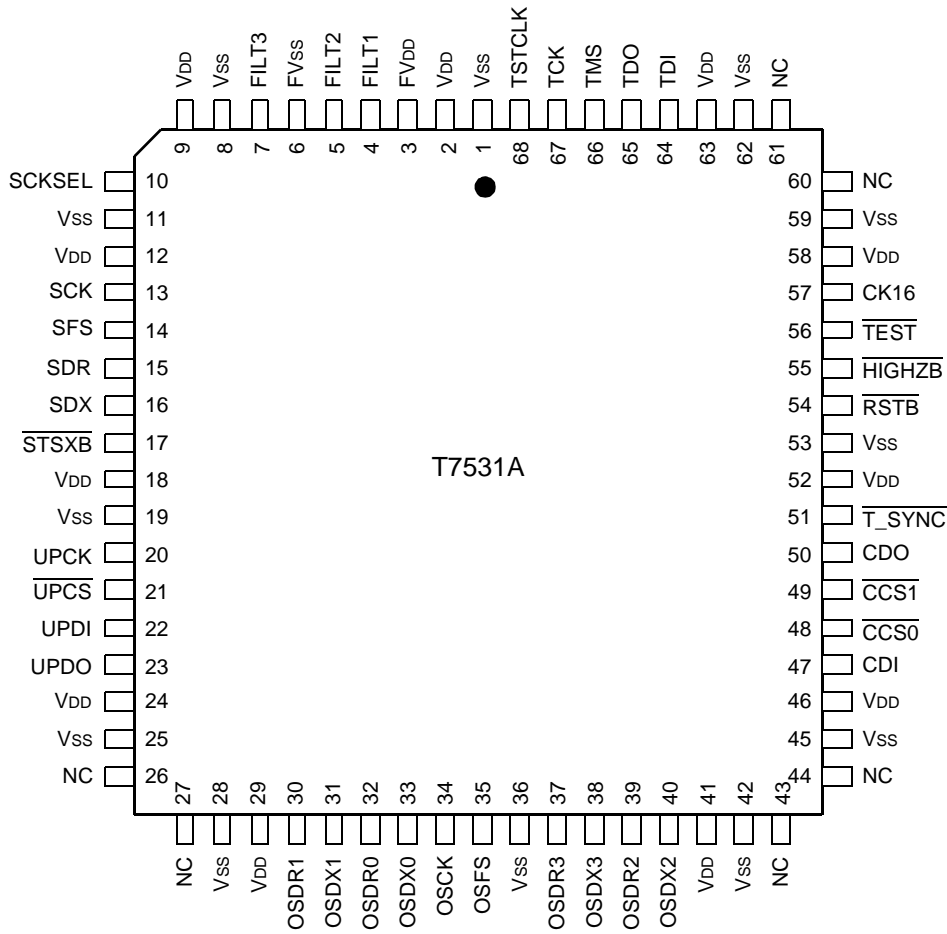

5-4231.b (F)

Figure 8. T7531A 68-Pin PLCC



Pin Information (continued)

Table 1. T7536 Pin Descriptions

Number	Name	Type	Name/Function
9, 17, 19, 27, 43, 51, 53, 61	VTX[7:0]	AI	<b>Analog Input.</b> Transmit signal voltage to be encoded.
10, 16, 20, 26, 44, 50, 54, 60	VRTX[7:0]	AI	<b>Transmit Reference Voltage.</b> +2.4 V reference. Each pin must have a separate supply associated with the corresponding VTX pin.
11, 15, 21, 25, 45, 49, 55, 59	VRP[7:0]	AO	<b>Noninverting Receive Output.</b> This pin can drive high-impedance loads either differentially or single ended. It is the complement of the VRN output.
12, 14, 22, 24, 46, 48, 56, 58	VRN[7:0]	AO	<b>Inverting Receive Output.</b> This pin can drive high-impedance loads either differentially or single ended. It is the complement of the VRP output.
8, 18, 28, 38, 42, 52, 62	V <sub>DDA</sub>	—	<b>+5 V Analog Power Supply.</b> Power supply decoupling capacitor (0.1 $\mu$ F) should be connected from each V <sub>DDA</sub> pin to analog ground. Capacitors should be located as close as possible to the device pins.
13, 23, 31, 47, 57	V <sub>SSA</sub>	—	<b>Analog Ground.</b>
63	V <sub>DDD</sub>	—	<b>+5 V Digital Power Supply.</b> Decouple with a 0.1 $\mu$ F capacitor to digital ground.
7	V <sub>SSD</sub>	—	<b>Digital Ground.</b>
5, 4	OSDX[1:0]	CO	<b>Oversampled Transmit Data.</b> Four channels of 1.024 MHz $\Sigma$ - $\Delta$ transmit data is transmitted to the T7531A through each of these pins. The data rate is 4.096 MHz.
6, 3	OSDR[1:0]	CI	<b>Oversampled Receive Data.</b> Four channels of 1.024 MHz $\Sigma$ - $\Delta$ receive data is received from the T7531A on each of these pins. The data rate is 4.096 MHz.
2	OSCK	CI	<b>Interface Clock.</b> The 4.096 MHz clock that enters this pin from the T7531A serves as the bit clock for all the oversampled data transmission between this chip and the T7531A. This is the master clock input for the T7536.
1	OSFS	CI	<b>Interface Frame Sync.</b> This signal serves as the frame sync for the oversampled data interface between the T7536 and the T7531A.
66	CDI	CI	<b>Control Data Interface Input.</b> The T7531A sends control register address and data to the T7536 through this pin. One address byte and one data byte are accepted each time $\overline{\text{CCS}}$ is toggled.
64	CDO	CO	<b>Control Data Interface Output.</b> Control register contents are clocked out through this pin.
65	$\overline{\text{CCS}}$	CI	<b>Control Interface Chip Select (Active-Low).</b> This active-low input enables the control interface.
68	$\overline{\text{RSTB}}$	TI <sup>u</sup>	<b>Reset (Active-Low).</b> This input must be pulled high for normal operation. When pulled momentarily low (at least 1 $\mu$ s) while OSCK is active, all programmable registers in the device are reset to the states specified under powerup initialization. This pin has an internal pull-up resistor.
67	TEST	TI <sup>d</sup>	<b>Test.</b> This pin is for factory test purposes only. Connect to V <sub>DDD</sub> for normal operation. This pin has an internal pull-down resistor.
29, 30, 32—37, 39—41	NC	—	<b>No Connect.</b> No connection to chip. These pins can be used as logic level tie points.

Note: TI = TTL input, TO = TTL output; CI = CMOS input, CO = CMOS output; AI = analog input, AO = analog output; I<sup>d</sup> indicates a pull-down device is included on this lead, I<sup>u</sup> indicates a pull-up device is included on this lead.

Pin Information (continued)

Table 2. T7531A Pin Descriptions

Number	Name	Type	Name/Function
22	UPDI	TI	<b>Control Data Interface Input.</b> The microcontroller sends control register address and data to the T7531A through this pin.
23	UPDO	TO	<b>Control Data Interface Output.</b> The microcontroller receives control register contents from this pin. Inactive state is high impedance.
20	UPCK	TI	<b>Control Data Interface Clock.</b> Bit clock for the control interface. Speed is limited to 4.096 MHz.
21	$\overline{\text{UPCS}}$	TI	<b>Control Interface Chip Select (Active-Low).</b> This active-low input enables the control interface.
38, 40, 31, 33	OSDX[3:0]	CI	<b>Oversampled Transmit Data.</b> Four channels of 1 Msamples/s $\Sigma$ - $\Delta$ transmit data are received from the T7536 chips through each of these pins. The data rate is 4.096 MHz.
37, 39, 30, 32	OSDR[3:0]	CO	<b>Oversampled Receive Data.</b> Four channels of 1 Msamples/s $\Sigma$ - $\Delta$ receive data is transmitted to the T7536 chips on each of these pins. The data rate is 4.096 MHz.
34	OSCK	CO	<b>4.096 MHz Clock.</b> Clock for data transfer to/from T7536 chips.
35	OSFS	CO	<b>Oversampling Sync.</b> 8 kHz synchronization pulse for data transfer to/from T7536 chips.
4	FILT1	—	<b>Filter.</b> External filter pin for the clock synthesizer block. Connect a 6.8 k $\Omega$ , 10% resistor in series with a 0.1 $\mu$ F, 20% capacitor to ground. Placement of these components is not as critical as power supply decoupling capacitor placement.
5	FILT2	—	<b>Filter.</b> External filter pin for the clock synthesizer block. Connect a 6.8 k $\Omega$ , 10% resistor in series with a 0.1 $\mu$ F, 20% capacitor to ground. Placement of these components is not as critical as power supply decoupling capacitor placement.
7	FILT3	—	<b>Filter.</b> External filter pin for the clock synthesizer's voltage regulator. Connect a 0.1 $\mu$ F, 20% capacitor to ground.
3	FV <sub>DD</sub>	—	<b>Synthesizer V<sub>DD</sub>.</b> Power supply for clock synthesizer block.
6	FV <sub>SS</sub>	—	<b>Synthesizer Ground.</b> Ground connection for the clock synthesizer block.
17	$\overline{\text{STSXB}}$	TO	<b>Backplane Drive Enable (Active-Low).</b> Active when SDX is transmitting valid data; high impedance otherwise. This pin provides an enable signal for a backplane line driver.
13	SCK	TI	<b>Master Clock Input.</b> This is the bit clock used to shift data into and out of the SDR and SDX pins. It is the input to the clock synthesizer and is used to generate all internal clocks. Rate is 4.096 MHz.
10	SCKSEL	TI <sup>U</sup>	<b>Master Clock Select Input.</b> A logic low selects the 2.048 MHz SCK. A logic high selects the 4.096 MHz SCK. An internal pull-up device is included, providing 4.096 MHz SCK operation with no external connections.
15	SDR	TI	<b>Receive PCM Input.</b> The data on this pin is shifted into the T7531A on the falling edges of SCK. Data is only entered for valid time slots as defined in the TSA registers.

Note: TI = TTL input, TO = TTL output; CI = CMOS input, CO = CMOS output; AI = analog input, AO = analog output; I<sup>U</sup> indicates a pull-up device is included on this lead.

**Pin Information** (continued)

**Table 2. T7531A Pin Descriptions** (continued)

Number	Name	Type	Name/Function
16	SDX	TO	<b>Transmit PCM Output.</b> This pin remains in the high-impedance state except during the transmit time slots as defined in the TSA registers. Data is shifted out on the rising edge of SCK.
14	SFS	TI	<b>Frame Sync.</b> Active-high pulse or square wave with an 8 kHz pulse repetition rate. The rising edge defines the start of the transmit and receive frames.
50	CDO	CO	<b>T7536 Control Data Output.</b> Control register information for the T7536 chips. Data is valid only when either CCS0 or CCS1 is low.
47	CDI	TI <sup>u</sup>	<b>T7536 Control Data Input.</b> Control register information from the T7536 chips. Data is valid only when either $\overline{\text{CCS0}}$ or $\overline{\text{CCS1}}$ is low. An internal pull-up device is provided.
49, 48	$\overline{\text{CCS}}[1:0]$	CO	<b>Control Interface Chip Select.</b> These active-low outputs select one of the associated T7536 chips.
67	TCK	TI	<b>JTAG Common Test Clock.</b> Rate $\leq 20$ MHz.
64	TDI	TI <sup>u</sup>	<b>JTAG Serial Data Input.</b> A pull-up device is provided.
65	TDO	TO	<b>JTAG Serial Data Output.</b>
66	TMS	TI <sup>u</sup>	<b>JTAG Mode Select.</b> A pull-up device is provided.
55	$\overline{\text{HIGHZB}}$	TI <sup>u</sup>	<b>3-State Control Pin (Active-Low).</b> When pulled low, the device output pins go into a high-impedance state. A pull-up device is provided.
56	$\overline{\text{TEST}}$	CI <sup>u</sup>	<b>Test Mode Input (Active-Low).</b> This input allows bypass of clock synthesizer and uses TSTCLK to drive the chip. A pull-up device is provided.
57	CK16	CO	<b>16 MHz Clock Output.</b> 16 MHz clock output (50% duty cycle).
68	TSTCLK	CI	<b>Test Clock.</b> Test mode 98.304 MHz clock input for bypass of clock synthesizer.
26, 27, 43, 44, 60, 61	NC	—	<b>No Connect.</b> Do not make any connections to these pins.
51	$\overline{\text{T\_SYNC}}$	CI <sup>u</sup>	<b>Test Sync (Active-Low).</b> Used for factory testing. Do not make any connection to this pin. A pull-up device is provided.
54	$\overline{\text{RSTB}}$	TI <sup>u</sup>	<b>Reset (Active-Low).</b> A logic low initiates reset. A pull-up device is provided.
2, 9, 12, 18, 24, 29, 41, 46, 52, 58, 63	V <sub>DD</sub>	—	<b>+5 V Digital Power Supply.</b> Power supply decoupling capacitors (0.1 $\mu\text{F}$ ) should be connected from each V <sub>DD</sub> pin to ground. Capacitors should be located as close as possible to the device pins.
1, 8, 11, 19, 25, 28, 36, 42, 45, 53, 59, 62	V <sub>SS</sub>	—	<b>Digital Ground.</b>

Note: TI = TTL input, TO = TTL output; CI = CMOS input, CO = CMOS output; AI = analog input, AO = analog output; I<sup>u</sup> indicates that a pull-up device is included on this lead.

## Chip Set Functional Description

### Transmit Path

#### Antialias Filter and $\Sigma$ - $\Delta$ Converter

The line interface circuit must provide a transmit signal, VTX, and a reference voltage, VRTX, which is the dc voltage of the VTX signal for that channel.

The input signal goes into a programmable-gain amplifier. The signal is then passed through an antialias filter followed by a  $\Sigma$ - $\Delta$  A/D converter. The  $\Sigma$ - $\Delta$  converter operates at 1.024 MHz. The processed output signals are multiplexed into two groups of four channels each onto output pins OSDX[1:0], each of which operates at 4.096 MHz.

A precision, on-chip voltage reference helps ensure accurate and highly stable transmission levels.

It is important to understand the difference between how the gain levels should be set in the T7536 and how these levels would be set in a standard codec. The T7536 is best thought of as a data acquisition system, not a codec. Hybrid balance, fine gain adjust,  $\mu$ - or A-law coding, filtering, and equalization are done after the A/D in the T7536 by the DSP processor in the T7531A. The analog gain adjust taps should not be used to set the absolute level at the PCM output. This can be done using the DSP gain adjust taps. The analog taps should be set so the signal at the input to the A/D converter is as close as possible to the full-scale input level of the A/D for the largest signal level that will be present at the VTX input. This optimizes the dynamic range of the A/D. The 0 dB gain tap should thus be used if the maximum signal level is in the range between 2.25 Vp-p and 3.2 Vp-p. The 3 dB tap should be used for signals with a maximum signal level in the range between 1.6 Vp-p and 2.25 Vp-p. The 6 dB tap should be used for signals with a maximum signal level in the range between 1.1 Vp-p and 1.6 Vp-p. Higher gain levels should be used for signals with smaller absolute levels.

The signal level to produce a 0 dBm0 level at the digital transmit output of the T7531A is not a fixed quantity as explained above. For a line with a complex impedance or an RX echo signal, extra headroom must be allowed and the TX signal level must be set to account for the headroom. In this specification, the largest possible 0 dBm0 level for the TX signal is assumed. This guarantees that the distortion specification will not be exceeded for all practical 0 dBm signal levels. The largest possible 0 dBm signal is one that has no headroom

for TX gain equalization. For the case of 0 dB transmit gain, this level is found as:

$$(3.2 \text{ V} / \log^{-1} (3.15/20)) = 2.23 \text{ Vp-p.}$$

This level is the worst-case 0 dBm0 level.

#### Decimator

The decimator filters out the high-frequency components and down-samples to 16 kHz. It also reorders the 16 channels of transmit signals into a sequence that is determined by the time-slot assignment.

#### Digital Transmit Gain Adjustment

The transmit absolute and relative gains are specified as 15-bit binary numbers representing their linear magnitude. These gains default to 4000 Hex. This equates to a 0 dB gain for the relative gain but equates to a 1.65 dB gain for the absolute gain. For a 0 dB gain, program the absolute gain for 34ED Hex. Gain can be varied from minus infinity dB (off) (0000 Hex) to 6 dB relative gain or 7.65 dB absolute gain (7FFF Hex).

The relative gain control allows TLP adjustment without hybrid balance or termination coefficient modification.

#### Band Filtering

The bandpass filter in the transmit path removes power line and ringing frequencies, and eliminates most of the signal energy at 4 kHz and above. This allows the encoder to transmit the filtered signal at 8 ksamples/s, the worldwide standard.

The transmit filtering is implemented with a low-pass filter, followed by a high-pass filter. The data samples enter the filter at 16 ksamples/s. They are first low-pass filtered to 3.4 kHz. After low-pass filtering, the sampling rate is reduced to 8 ksamples/s. The samples are then high-pass filtered to 300 Hz.

The low-pass filter also serves as an equalizer for complex termination impedance cases. A given set of equalizer coefficients that modify this filter are required for each complex termination impedance. These are supplied in the user manual.

#### $\mu$ -Law, A-Law, and Linear PCM Modes

In the transmit path, the 8 ksamples/s PCM signal output from the filter is processed prior to transmission over the system interface. The 16-bit linear PCM signal may be compressed according to either  $\mu$ -law or A-law, or transmitted as two consecutive 8-bit words. The selection is programmable via the microprocessor interface. Please note, when using A-law, a linear value of 0 is always encoded as 7F.

## Chip Set Functional Description

(continued)

### Receive Path

In the receive direction, the signal received from the system interface is converted to a 16-bit linear PCM signal.

### Receive Path Filtering

The 16-bit linear PCM signal is filtered and interpolated to 16 ksamples/s to meet the receive signal loss characteristics. This filter smooths the data following interpolation from 8 ksamples/s to 16 ksamples/s.

### Digital Receive Gain

The receive absolute and relative gains are specified as 15-bit binary numbers representing their linear magnitude. These gains default to 4000 Hex. This equates to a 0 dB gain for the relative gain but equates to a -0.211 dB gain for the absolute gain. For a 0 dB gain, program the absolute gain for 4193 Hex. Gain can be varied from minus infinity dB (0) (0000 Hex) to 6 dB relative gain or 5.8 dB absolute gain (7FFF Hex).

The relative gain control allows TLP adjustment without hybrid balance or termination coefficient modification.

### Interpolator and Digital Sigma-Delta Modulator

The sampling frequency of the receive signal from the digital gain adjustment is increased from 16 kHz to 64 kHz by the interpolator, which removes most of the high-frequency signal images above 8 kHz. The interpolator also maps each of 16 time slots to the appropriate line channel through the digital sigma-delta modulator.

The digital sigma-delta modulator converts the interpolated signal to a 1.024 MHz bit stream which is then sent to the T7536 device.

### Decoder, Filters, and Receive Amplifier

Receive data enters the T7536 on pins OSD[1:0] at 4.096 MHz; four channels are time-division multiplexed onto each pin. The data is demultiplexed into eight individual channels. The processed signal for each channel passes through switched-capacitor D/A and reconstruct filters, followed by a smoothing filter. A programmable gain amplifier is included, followed by an output amplifier capable of driving a 50 k $\Omega$  load to  $\pm 1.58$  V single-ended (relative to VOS) or  $\pm 3.16$  V differential at peak overload. For single-ended operation, the load must be ac coupled to VRP (or VRN).

## Other Chip Set Functions

### Voltage Reference

The T7536 has a precision on-chip voltage reference which ensures accurate and highly stable transmission levels.

### Hybrid Balance

The hybrid balance function is provided as a digital block in the T7531A.

The T7531A implements a 9-tap FIR and a single-pole IIR digital balance filter in which a replica of the echo is digitally subtracted from the transmit plus near-end echo signal. The coefficients are user programmable on a per-line basis via the microprocessor interface.

### Analog Termination Impedance Synthesis

Termination impedance matching is implemented to maximize the power transfer capability at the loop interface and to minimize signal reflections between the transmit and receive paths.

The resistive component, implemented in the T7536 device, comprises a variable attenuated path between VTX and VRP. The capacitive component is implemented in the digital domain.

Analog termination impedance (ATI) is provided with 16 gain settings to match a voltage drive/current sense line interface circuit with the following characteristics:

$$Z_T = 2R_P + G_{TX} * G_{RX} * A_T$$

where  $Z_T$  is the termination impedance in ohms,  $R_P = 82.5 \Omega$  is the resistance of each protection resistor,  $G_{TX}$  is the SLIC transmit gain (300 V/A for the L7585),  $G_{RX}$  is the SLIC receive gain (2 for the L7585), and  $A_T$  is the T7536 feedback gain. The polarity of the  $A_T$  gain is positive (positive voltage swing on VTX gives a positive voltage swing on VRP). The gain values and the corresponding effective termination impedance are shown in Table 26; gain tolerances are  $\pm 2\%$ . Differential receive output is assumed.

## **Chip Set Functional Description**

(continued)

### **Other Chip Set Functions** (continued)

#### **Digital Termination Impedance Synthesis**

The CTZ filter in the T7531A synthesizes complex termination impedances. The CTZ filter utilizes alpha and beta coefficients (board control words 4 and 5, respectively) to perform the synthesis. One set of alpha and beta coefficients is required for each termination impedance and balance network. These are provided in the user manual. Alpha bits [9:0] represent the RC time constant of the impedance that the filter is going to synthesize. The bits are formatted as two's complement. Alpha bits must be a nonzero value. Beta bits [7:0] represent the dc gain of the filter. Beta coefficients are also formatted as two's complement. Setting beta equal to zero turns off the CTZ function.

There is a constraint on the value of the protection resistor with regard to termination impedance synthesis and hybrid balance. For synthesis to operate properly, the total series Tip/Ring resistance must be 165  $\Omega$  or greater. Coefficients for use with the L7585 SLIC are set up for a protection value resistance of 82.5  $\Omega$  in Tip and 82.5  $\Omega$  in Ring.

#### **Loopback Modes**

There are four loopback modes in the T7536.

The first two loopback modes are controlled by the all channel test (ACT) register. ACT bits 0 and 1 place all eight channels into loopback mode. Analog and digital loopback are described and shown in block diagram form in Table 29. Analog loopback allows one to check functionality from Tip/Ring up to and including the T7536. Digital loopback allows the T7531A to check T7536 functionality.

The third loopback mode is used in the autocalibration sequence (control register 2). This mode provides a loopback between a selected channel and channel four of a given T7536. The channel to be calibrated is selected via control register 1 (see Table 27). Channel four is the only channel in the T7536 that is trimmed for gain accuracy. Every other channel uses channel four as a reference and is calibrated to it during the autocalibration sequence.

The fourth loopback mode is a digital loopback mode located in control register 1. This operates like the digital loopback mode described in the notes for the ACT register (Table 29). Unlike the ACT register, this digital loopback mode is selectable per channel. This loop-

back mode can be used to check T7536 functionality from the T7531A device. It is also used during the calibration sequence.

There is one loopback mode in the T7531A. Loopback at the oversampled data interface is controlled by board control word 1. This mode allows the T7531A to test itself. When bit 0 of 0x1FFE is selected, all 16 channels of octal interface receive data (OSDRn) are looped back to the T7531A transmit inputs (OSDXn).

#### **Interchip Control Interface**

The control interface is a 4-pin interface used to send control information to the T7536 from the T7531A, and to read back the control register contents. The pins consist of a chip select input ( $\overline{\text{CCS0/CCS1}}$ ), a data input (CDI), and a data output (CDO). The transfer of control data is synchronous with the 4.096 MHz OSCK, which is also used for oversampled data transfer.

## **T7531A Functional Blocks**

### **Clock Synthesizer**

The clock synthesizer block is a phase-lock loop (PLL) circuit which takes SCK supplied by the backplane and uses it to produce the 98.304 MHz DSP engine clock. The input clock, SCK, can be 2.048 MHz or 4.096 MHz.

An on-chip clock synthesizer has the advantages shown below:

- Precludes the need for extra clocks to be fed over the backplane.
- Constrains the high-speed DSP engine clock within the device.
- Synchronizes all clocks used on the line card to the backplane clock, thus reducing board noise due to beat frequencies.

A clock generator block takes the PLL output and divides it down to produce all the lower-frequency clocks used by the T7531A and T7536.

### **T7531A System Interface**

The system interface is a full-duplex interface used for the exchange of PCM data with the system. The system is the master of this bus. No control information is transmitted over the system interface; all control instructions are routed over the microprocessor interface.

## Chip Set Functional Description

(continued)

### T7531A Functional Blocks (continued)

The system interface is used for all 16 lines serviced by the T7531A. The PCM data rate is 8 ksamples/s/line, so the total required channel capacity is  $16 \times 8 = 128$  Kwords/s in each direction. At the 4.096 MHz rate, each word takes 1.95  $\mu$ s to transmit interleaved with 5.86  $\mu$ s of dead time. The frame sync, SFS, is presented to the system interface at an 8 kHz rate.

A single bit clock and frame sync are used to control both the transmit and receive directions. The beginning of the first time slot in a frame is identified from the SFS input (see Figure 9). In nondelayed mode, SFS is active coincident with bit 0 of time slot 0 of the RX frame (and the TX frame if the programmed offset between TX and RX is 0). In delayed mode, SFS is active one cycle earlier.

The amount of skew or offset between the transmit and receive frames and time slots is programmable via board control word 2, 0x1FFC. The bit offset is up to a frame, i.e., up to 511 bits in 4 MHz mode. See Table 36 for a listing of invalid bit offset values. The bit offset skew takes place in the system PCM interface block.

The active transmit and receive time slots are determined by the card address. The number of time slots within a frame varies according to the rate of SCK. Only 16 time slots are ever active in a frame, as shown in Table 3.

The T7531A obtains its card address in board control word 1, 0x1FFE.

In  $\mu$ -law or A-law mode, each PCM word is only 8 bits long and occupies one time slot. In linear mode, the PCM word is 16 bits long and occupies two adjacent time slots. The MSB is the first bit clocked out in the valid time slot, and the LSB is the last bit of the following (invalid) time slot.

### T7531A Microprocessor Interface

This interface between the microprocessor (or other external controller) and the T7531A device carries user-supplied program variables and control and test instructions to both the T7531A and the T7536 octal converters. The external device is the master of the microprocessor interface. The interface is serial and asynchronous, and consists of four pins (UPCK, UPCS, UPDI, UPDO). The data rate is determined by the customer's choice of external device, but may not exceed 4.096 MHz. Microprocessor interface commands consist of two words, address and data. Address and data are 16 bits wide. The T7531A expects an address first. The first bit of the address word is the R/W flag, which tells the T7531A whether it must receive or send data (receive, R/W = 0; send, R/W = 1).

Addresses less than 0x1400 refer to the DSP engine RAM space. If a read from the DSP engine is required, the microprocessor interface issues a read interrupt to the DSP engine. If it's a write to the DSP engine, the microprocessor interface shifts in the data word and saves it into the data register before sending a write interrupt to the DSP engine. Once in every 7.8  $\mu$ s time segment, the DSP engine checks whether an interrupt is outstanding from the microprocessor interface block.

If so, the DSP engine reads the address register. If it's a read, the DSP engine fetches the word from RAM, places it in the data register, and shifts it out to the microprocessor. If it's a write, it puts the contents of the data register into RAM.

A pause therefore exists between the external controller issuing an address and receiving a data read back. The data rate of 2.048 MHz allows 256 SCK cycles in a frame, i.e., eight address/data pairs with no pause between words. Since the DSP engine can process only one interrupt every 7.8  $\mu$ s, the T7531A requires a separation between address and data on read and write instructions to the microprocessor interrupt (see Figure 10). This, in effect, requires UPCK to be gapped.

Table 3. Active Time-Slot Spacing in a PCM Bus Frame

SCK Rate (MHz)	Total # of Time Slots	Card Address	Valid Time Slots	Invalid Time Slots
2.048	32	0 1	0, 2, 4, . . . 30 1, 3, 5, . . . 31	1, 3, 5, . . . 31 0, 2, 4, . . . 30
4.096	64	0 1 2 3	0, 4, 8, . . . 60 1, 5, 9, . . . 61 2, 6, 10, . . . 62 3, 7, 11, . . . 63	1—3, 5—7, . . . 61—63 0, 2—4, 6—8, . . . 62—63 0—1, 3—5, 7—9, . . . 63 0—2, 4—6, 8—10, . . . 60—62

## **Chip Set Functional Description**

(continued)

### **T7531A Functional Blocks** (continued)

Addresses  $\geq 0x1400$  refer to registers or TSA RAM external to the DSP engine. If the address word from the microprocessor is  $0x1400$  through  $0x140F$ , it activates the TSA state machine. If the address word from the microprocessor is  $0x1500$  through  $0x15FF$ , it activates the T7536 control state machine.

Microprocessor data and address words can be flushed out of the T7531A by addressing  $0x7FFF$  with data word  $0xFFFF$  (see Table 40).

### **T7536 Octal Control Interface**

The two T7536 chips cannot be accessed by the microcontroller directly; the T7536's registers are all accessed via the T7531A microprocessor interface. The microprocessor communicates serially with the T7536 by simply writing or reading 16-bit address and 16-bit data. The octal control interface block translates this address and data into 8-bit address and 8-bit data needed by the T7536. The octal control interface block waits until the microprocessor interface block receives all 16 bits of the address word and determines whether this is a read or write operation by looking at bit 15. If this is a write operation for a T7536 chip, it receives another 16-bit data word.

### **T7531A Time-Slot Assignment (TSA)**

The TSA block contains a  $16 \times 6$  dual-port RAM which is readable or writable via the microprocessor interface. Table 18 gives the bit map for TSA RAM words. The TSA RAM is in time-slot order, i.e., location  $0x1400$  is for time slot 0 and  $0x1401$  for time slot 1 and so on. The low 4 bits (B3—B0) indicate which of the 16 possible channel numbers is assigned to this time slot. The time-slot assignment is controlled by the microprocessor writing to address  $0x1400$  through  $0x140F$ .

The TSA block also generates the control signals and flags used to synchronize the TSA, interpolator and decimator, and T7536 interface blocks. The TSA RAM is not preinitialized, so the microprocessor is required

to write to all 16 locations of the TSA RAM at start-up to ensure proper operation. Twice a frame, the TSA state machine reads the entire TSA RAM from top to bottom in sequence and sends the contents of each RAM location to the interpolator as channel numbers for RX channels. The TSA state machine performs the same procedure for the decimator to provide it with the TX channel numbers. By performing TSA at the over-sampled sigma-delta rate, round trip group delay is significantly minimized.

## **DSP Engine Timing**

The DSP engine processes all 16 lines every frame. In order to simplify synchronization of data exchanges, the processing frame is broken into 16 equal time segments of  $7.8 \mu\text{s}$  each. The ROM code is identical for each time segment.

Synchronization between the engine and the rest of the chip is enforced by the system interface block, which issues an interrupt every  $7.8 \mu\text{s}$ . This interrupt is the only unmasked interrupt processed by the engine. The interrupt service routine forces the ROM code to branch to the start of the processing loop.

## **T7531A Program Structure**

The DSP engine firmware performs three types of operations:

1. Signal processing of the ac path data.
2. RAM accesses initiated by the microprocessor interface.
3. Data and program flow operations.

The signal processing algorithms performed by the T7531A are implemented in firmware and are held in ROM.

Many firmware parameters are user programmable via the microprocessor interface. Interrupts from the microprocessor interface are handled once every time segment ( $7.8 \mu\text{s}$ ), and the appropriate accesses are made to the DSP engine RAM registers.



## Chip Set Functional Description

(continued)

### Control of the DSP Engine via the Microprocessor Interface

There are four types of commands that the external controlling device may issue to the DSP engine:

1. Downloading data to RAM.
2. Activating and deactivating lines.
3. Changing the RX and TX routine to be run.
4. Periodic read and/or refresh of RAM space.

All of these commands must only involve reading and writing to the DSP RAM so that the DSP engine does not have to perform test- and branch-type operations when a microprocessor interface command is received. The complete memory map for the DSP engine RAM is given in Table 18. The microprocessor interface is allowed to read any RAM location in the DSP engine and to write to specified addresses.

### The DSP Engine Time-Slot Information Tables

In the T7531A, the DSP engine RAM has been set up to contain 16 tables which hold the pointers to the ac coefficients and data buffers required to process each time slot. Each table starts on a 32-word boundary and is accessed in the firmware using direct addressing instructions. Each table has an RX part and a TX part (see Table 18).

The tables are labeled 0 through 15 and are in time-slot order, i.e., table 0 is used when processing data for time slot 0. Time-slot number can vary between 0 and 15 and is used in conjunction with the card address to provide up to 63 time-slot positions on the PCM bus (see Table 3).

### The DSP Engine ac Path Coefficient Table

The microprocessor interface can control the DSP coefficients, shown in Table 4. The DSP engine RAM contains space to hold separate sets of coefficients for each channel, labeled channel\_0 through channel\_15. The coefficients are held in channel order, since they hold information that is channel specific and does not change with the time slot (see Table 18).

Table 4 shows the ac path coefficient space for channel\_0.

**Table 4. DSP Engine RAM Map for Channel\_0 ac Path Coefficients**

RAM Address	Purpose	Number of Words	Initial Value
rgain_rel_0	RX path relative gain	1	1 (4000 H)
Reserved	—	1	—
rgain_abs_0	RX path absolute gain	1	1 (4000 H)
tgain_abs_0	TX path absolute gain	1	1 (4000 H)
bf_coef_0	Balance filter coefficients	10	Not initialized
Reserved	—	1	—
tgain_rel_0	TX path relative gain	1	1 (4000 H)

## Chip Set Functional Description

(continued)

### The Time-Slot Control Word

The DSP engine works in time-slot order. The TSA function is performed by the decimator/interpolator. The DSP engine is not required to reorder the data in any way. The advantages of this approach are that the group delay introduced by the TSA function is very small, and the DSP code needed for context switching is small. When the microprocessor assigns a time slot via the TSA RAM, it also has to issue a new time-slot control word (TCW) instruction to the DSP engine to enable the time slot to link to the correct ac coefficients. The TCW contains the information shown in Tables 5A and 5B. The TCW is only looked at when a time slot is inactive. The initial setup of the TCWs assumes channel-order time-slot assignment.

## Operations Performed by the DSP Engine at T7531A Start-Up

The DSP engine performs its start-up code after it has been reset. All interrupts are disabled. First, the DSP engine computes the checksum for its ROM and RAM to verify their integrity. Next, the DSP engine walks through each time-slot information table and sets the data buffer and coefficient pointers. The DSP engine RAM is set up for channel-order time-slot assignment, i.e., table 0 points to channel\_0 and so on. The start-up settings for the Time-Slot Information Table (i.e., for time slot 0) are shown in Table 6.

The first 16 locations of RAM bank 1 hold the channel address table, where pointers to the start of the coefficient space for each channel are held. These pointers are set up during the start-up routine. Pointers to the three sets of default coefficients are also set up. The DSP engine then walks through all 16 ac coefficient tables and sets them to their initial values as shown in the previous section. The RX and TX filter coefficients (one set for all 16 lines) are taken from ROM and written to their RAM locations.

The DSP engine takes about 3 ms to execute the start-up code. At the end of the code, the interrupt system is enabled and the DSP engine enters sleep mode.

**Table 5A. Bit Maps for DSP Engine Time-Slot Control Word**

Register Bit	Function	Initial Value
0—3	Channel Number	channel_(time-slot number)
4	Go to Powerup	0
5	Modify Coefficients	0
6—7	Use Default Per-Board Coefficient Tables	0

**Table 5B. Bit Map for Default Per-Board Coefficient Tables**

Bit 7	Bit 6	Mode
0	0	Do Not Select Default Tables
0	1	Default Table 1 Coefficient Set
1	0	Default Table 2 Coefficient Set
1	1	Default Table 2 Coefficient Set

**Table 6. DSP Engine RAM Map for Time-Slot Information Table 0**

Variable	Function	Initialized Address
tcw_0	Time-slot Control Word	See above
rx_rtn_0	Address of Receive ac Routine	rpath_inactive
tx_rtn_0	Address of Transmit ac Routine	tpath_inactive
data storage	Reserved	NA

## Chip Set Functional Description

(continued)

### Microprocessor Start-Up of the DSP Engine

Once the interrupt system is enabled, the DSP engine looks for a read or write interrupt from the microprocessor interface once every time segment, i.e., 16 times a frame.

If the ac coefficients for every channel are to be independently controlled, the microprocessor can write directly to the addresses of the 16 ac coefficient tables. This requires a total of 16 microprocessor commands to set up each channel, i.e., 16 frames to set up all 16 channels. Prior to activating any time slots, the microprocessor has the option of bulk downloading the coefficients to set up the ac coefficient tables.

When a channel needs to be set up and linked to its time slot, the microprocessor must send the TCW for that time slot with the modify coefficient (MC) bit (see Table 5A). The MC bit causes the inactive routine for that time slot to set pointers from that time-slot space to the channel space in RAM. The MC bit also causes the inactive routine to check the default coefficient bits of the TCW. If set, the appropriate default table coefficients are copied over to the RAM space for the channel. This mechanism allows the microprocessor to download a set of coefficients that can be used by multiple channels.

A mix-and-match approach can be used, i.e., some channels are set up with independent sets of coefficients, while other channels get a default setting.

During start-up, the microprocessor must also download the 16 TSA commands used by the TSA block to map physical channels to time slots. This is required to initialize the TSA RAM to known values. When all 16 locations have been set up, the microprocessor must send BCW2 (0x1FFC). This flags the TSA control to start normal operation.

### Powering Up a Time Slot in the T7531A

Depending on the application, the microprocessor may choose to set up the ac coefficients for a channel just prior to enabling it for use. This requires 16 microprocessor commands if the coefficients must be set up from scratch, or no commands if an appropriate default set has already been set up. In either case, the microprocessor must ensure that all the TX and RX parts of a channel are set up prior to enabling the time slot.

If dynamic time-slot assignment is used, the microprocessor must next download a TSA command, which the TSA block uses to map the time slot to the required channel number.

The microprocessor must enable the time slot by setting the go to powerup bit of the TCW. This causes the DSP engine to change the TX and RX ac routine addresses to active.

A maximum of 17 commands or a minimum of one command is therefore needed to power up a channel.

### Disabling a Time Slot in the T7531A

To disable a time slot, the microprocessor must send a command that sets the address of either the TX or RX ac routine to TX\_inactive and RX\_inactive, respectively.

The inactive routines come into use in the next TX or RX time segment for this time slot. Upon returning from the inactive routine, the DSP engine checks for a microprocessor interrupt and then enters sleep mode for the rest of the time segment.

### T7536 Powerup/Powerdown

Each channel can be powered up independently. There are two control register addresses that can be used to control the power for each channel. In both cases, the first bit of the address word controls the power. P = 1 for powerup, and P = 0 for powerdown.

One address is provided for each channel which controls the power (0x1508—0x150F and 0x1548—0x154F), and the address is followed by a data word which controls the other programmable functions for the same channel. A second address (0x1500—0x1507 and 0x1540—0x1547) is provided for each channel that controls only the power.

## Chip Set Functional Description

(continued)

### Changing DSP RAM Space of an Active Time Slot

The microprocessor is only allowed to change four RAM locations for an active time slot:

- Relative transmit gain
- Relative receive gain
- Address of receive ac routine
- Address of transmit ac routine

Absolute gains and time-slot assignment can only be altered when the time slot is inactive. Note that the DSP engine does not check the TCW of active time slots.

Following the initial powerup, the line card is likely to be in service without being reset for as long as it continues to operate trouble-free. Therefore, the microprocessor has the option of continuously monitoring the variables it has programmed by reading them back from the DSP engine/microprocessor interface and rewriting them.

### DSP Engine Memory Requirements

The size of the DSP engine internal dual-port RAM is 2K x 16-bit words per DSP engine. RAM storage is used for user-programmable variables and for intermediate storage of the data being processed by the device. The RAM memory map is given in Table 18.

The on-chip ROM is used for both program and data. The DSP engine firmware is ROM based. The hardware development system code is also ROM based. The DSP engine ROM memory map is given in Table 41.

## T7531A Reset and Start-Up

The chips support both hardware and software reset.

### Hardware Reset

The T7531A reset functions are handled by the reset control block. Hardware reset occurs if the board is powered up with  $\overline{RSTB}$  low. Since  $\overline{RSTB}$  has a Schmitt trigger buffer with an internal pull-up, a capacitor attached external to the  $\overline{RSTB}$  pin causes the pin to pull high after a specified period of time. For power-on reset, the T7531A requires that this period of time be >1 ms to give the on-chip clock synthesizer block time to start producing clock edges for the T7531A and T7536 chips (although it may not have reached its final accuracy yet). Successful hardware reset of the device requires that:

1. The PCM bus signals SCK and SFS should be valid at the start of the 1 ms power-on reset period.
2.  $V_{DD}$  (and therefore  $\overline{RSTB}$ ) should have been low for at least 200 ms prior to commencing power-on reset to ensure that the JTAG controller powerup reset circuit has had time to clear the JTAG controller.

If, during normal operation,  $V_{DD}$  falls below the defined minimum value,  $V_{DD\ min}$ , the power-on reset procedure described above must be repeated.

Hardware reset occurs if  $\overline{RSTB}$  is pulsed high-low-high for 1 ms during normal operation (i.e., no loss of power).

**Table 7. Summary of Microprocessor Commands for Control of T7531A Data Processing**

Function Required	Number of Commands	When Issued
Bulk TSA register download & BCW2	17	Start-up
Individual TSA register download	1	Prior to activating a time slot via the TCW
Coefficient download	16 per channel	Start-up or when time slot is inactive
Set TCW to use/share coefficients already downloaded to default tables	1	Start-up or when time slot is inactive
Enable time slot via TCW (fixed TSA)	1	When time slot is inactive
Enable time slot via TCW (dynamic TSA)	2	When time slot is inactive
Disable time slot	1	When time slot is active
Change gain value	1 per gain	Any time

## Chip Set Functional Description

(continued)

### Internal Reset

Internal reset is defined as the process that starts when the internal reset line is brought low. This happens as a consequence of hardware (RTSB) or software (BCW1) reset. The internal reset process performs the following functions:

1. The frequency synthesizer does not receive any reset signal, and is thus unaffected by reset. Following power-on reset of the T7531A, the frequency synthesizer takes the mode determined by the SCKSEL pin.
2. The T7531A custom logic jams all resettable latches, counters, and registers to their default values. No data is latched on any of the T7531A interfaces during internal reset.
3. The DSP engine is held in reset state.
4. The internal reset line is held low for a minimum of 18 ms to allow the frequency synthesizer to reach its final accuracy. An internal counter is started when the internal reset line goes low. It counts 80 frame sync pulses on SFS before releasing the internal reset line.
5. When the internal reset line goes high and the EXM (internal) signal is held low, the DSP engine begins its start-up routine by fetching the first instruction from location 0 of the internal ROM.
6. At the rising edge of the internal reset line, all the T7531A custom logic blocks commence their normal operation.

### Reset of the T7536 Devices

There are two options for reset of the T7536 chips.

The T7536s can make use of the same hardware reset pulse as the T7531A. The T7531A supplies OSCK to the T7536s as soon as it is available, i.e., before the hardware reset has gone away. It is recommended that hardware reset be applied to all chips simultaneously.

Alternatively, the T7536s can be reset through software reset (Tables 21 and 22), which is generated by the external controlling device and routed to the T7536s via the T7531A. This can only occur when OSCK is guaranteed to be valid, i.e., not within 10 ms of power-on hardware reset.

### Start-Up After Internal Reset

There is a specific sequence of microprocessor interface instructions that must be followed after internal reset in order to properly configure the T7531A and T7536s for normal operation.

1. If nondefault values are required, the T7531A board control word 1 (address 0x1FFE) must be updated.
2. The 16 TSA RAM locations must be written before 0x1FFC. CTZ must be disabled (see Table 20B).
3. The all channel test register must be set for normal operation (addresses 0x1510 and 0x1550 set to 0x0004).
4. The T7531A control registers must be set. All 16 channels must be powered up (addresses 0x1500—0x1507 and 0x1540—0x1547 must be set to 0x8000).
5. The amplitude of the calibration sine wave must be set by writing address 0x0580 to coefficient 0xAA20, and address 0x0581 to coefficient 0xF49D.
6. All 16 channels must be put into initialization mode (addresses 0x1518—0x151F and 0x1558—0x155F must be set to 0x0080).
7. The DSP engine RAM address 0x0002 must be set to 0x0700 to begin the first part of the T7536 calibration start-up sequence.
8. After 70 ms, all 16 T7536 channels must be put into loopback mode (addresses 0x1508—0x151F and 0x1548—0x154F must be set to 0x8001).
9. The DSP engine RAM address 0x0002 must be set to 0x0720 to begin the second part of the T7536 calibration start-up sequence.
10. After 70 ms, both T7536s should be sent a soft reset (addresses 0x1517 and 0x1557 set to 0x8000) and the all channel test register should be set for normal operation (addresses 0x1510 and 0x1550 set to 0x0004). Normal T7531A operation commences with the next SFS frame sync. The chips are now ready for channels to be enabled and filter coefficients to be set.

## **Chip Set Functional Description**

(continued)

### **Autocalibration**

Autocalibration is an analog self-test and trimming procedure controlled by the DSP core. Sine wave signals are generated in the receive direction. These signals are looped back at the analog side of the T7536, and the return signal amplitudes are measured in the transmit path. This procedure provides on-the-spot fault coverage of the transmit and receive paths. It also calibrates the octal devices by modifying the gain on each channel. Channel four of the T7536 is the only channel trimmed at the factory for absolute gain accuracy. When autocalibration is run, all channels are trimmed with reference to channel four. That is, the gain on each channel is adjusted so that its absolute gain is equivalent to that of the trimmed channel. Performing trimming in this manner provides channel-to-channel gain matching of better than 0.01 dB. This is a much better performance than could be achieved using conventional trimming. Trimmed values are placed in data storage, and absolute gain values are then modified accordingly any time the absolute gain register is changed.

The calibration sequence measures the looped-back power result and compares it to the calibrated channel. The trim window is  $\pm 0.2$  dB. If any channel exhibits a power value which is greater than  $\pm 0.2$  dB, the calibration procedure sets a failure flag for that channel. Trimming will not be performed on the failed channel, and the channel's trimmed gain will be left at 0 dB. The failed channel, therefore, is left in its previous state and can still be used. The results of calibration are held in RAM address 0x07F4 for transmit (pass 1) and 0x07F5 for receive (pass 2). A bit is set high for every failed channel.

The preceding section discussed the sequence of instructions that must be followed in order to properly configure the T7531A for normal operation. The autocalibration procedure is mandatory after hardware reset.

### **User Test Features**

This section outlines the T7531A test features and architecture. For more information on the board-test capabilities, see the *T7531A/T7536 User Manual*.

### **Off-Line Programmable System Test Capability**

The T7531A has a standard 4-pin test access port known as JTAG that can be used for testing and debugging. The user has the option of downloading custom firmware to the DSP engine RAM via the JTAG port, and running it in the DSP engine in place of the normal ROM-based code. The DSP16 hardware development tool provides a powerful user interface for real-time code development and debug. The user can also execute the self-test ROM routine which exercises significant portions of the T7531A and T7536 devices.

### **On-Line Per-Channel Test Capability**

In addition to the active (i.e., normal voice processing functions) and inactive routines, the user can select the routines listed in Table 41 by altering the TX and RX routines address in the time-slot information table (see Table 6).

### **Inactive Mode with Loopback**

This is a pair of routines that are used for the TX and RX parts of the channel. Data from SDR is looped back without modification to SDX.

### **Self-Test and Board-Test Routines**

Using the following routines, programs can be written to test not only the codec function but also all attached circuitry, like the SLIC, relays, protection devices, and cabling.

### **Tone Generation**

In tone generation mode, the RX part of the channel is used to send a sine wave signal out to the line. The sine wave can be up to 4 kHz in frequency, and up to 1024 points long. The RX filter is not implemented in tone generation.

## Chip Set Functional Description

(continued)

### Self-Test and Board-Test Routines

(continued)

#### Tone Detection

In tone detection mode, the TX part of the channel can be used to detect signal energy from the line at a given frequency up to 4 kHz. This routine performs discrete Fourier transform (DFT) to capture and analyze the reflected tone. The routine does not employ the transmit bandpass filters. The number of frames to sample the reflected tone must be defined. The number of frames that DFT is run must be a power of 2 and should be complete cycles of tone value.

#### dc Generation

This routine generates a dc signal (value defined by user) in the RX path.

#### Variance Computation

The variance routine computes the variance of small noise signals from the TX path around the computed mean level. This routine employs the transmit bandpass filters for out-of-band noise reduction.

#### Peak Detection

This routine examines the incoming TX signal and saves the maximum and minimum signal values.

## Handling Precautions

Although protection circuitry has been designed into this device, proper precautions should be taken to avoid exposure to electrostatic discharge (ESD) during handling and mounting. Lucent Technologies employs a human-body model (HBM) and a charged-device model (CDM) for ESD-susceptibility testing and protection design evaluation. ESD voltage thresholds are dependent on the circuit parameters used to define the model. No industry-wide standard has been adopted for the CDM. A standard HBM (resistance = 1500  $\Omega$ , capacitance = 100 pF) is widely accepted and can be used for comparison. The HBM ESD threshold presented here was obtained by using these circuit parameters:

HBM ESD Threshold	
Device	Voltage (V)
T7531A	>1000
T7536	>1000

## Absolute Maximum Ratings

Stresses in excess of the absolute maximum ratings can cause permanent damage to the device. These are absolute stress ratings only. Functional operation of the device is not implied at these or any other conditions in excess of those given in the operational section of the data sheet. Exposure to absolute maximum ratings for extended periods can adversely affect device reliability.

Parameter	Symbol	Min	Max	Unit
Ambient Operating Temperature	T <sub>A</sub>	-40	85	°C
Operating Junction Temperature	T <sub>J</sub>	-40	125	°C
Thermal Resistance, Junction to Case	R <sub>θJC</sub>	—	35	°C/W
Storage Temperature Range	T <sub>stg</sub>	-55	150	°C
Power Supply Voltage	V <sub>DD</sub>	4.75	5.25	V
Voltage on Any Pin with Respect to Ground	V <sub>SS</sub>	-0.25	5.25	V
Package Power Dissipation	P <sub>D</sub>	—	1	W

## Electrical Characteristics

For all specifications:  $T_A = -40\text{ }^\circ\text{C}$  to  $+85\text{ }^\circ\text{C}$ ,  $V_{DD} = 5\text{ V} \pm 5\%$ , unless otherwise noted. Typical values are for  $T_A = 25\text{ }^\circ\text{C}$  and  $V_{DD} = 5\text{ V}$ . Input signal frequency is 1020 Hz, unless otherwise noted.

### dc Characteristics

Table 8. Digital Interface

Parameter		Symbol	Test Conditions	Min	Typ	Max	Unit	
Input Voltage	Low	$V_{IL}$	TTL-compatible inputs	—	—	0.7	V	
	High	$V_{IH}$	TTL-compatible inputs	2.0	—	—	V	
Output Voltage	Low	$V_{OL}$	$I_L = 10\text{ mA}$	—	—	0.4	V	
	High	$V_{OH}$	$I_L = -10\text{ mA}$	2.4	—	—	V	
		$V_{OHC}$	$I_L = -320\text{ }\mu\text{A}$	3.5	—	—	V	
Input Current	Pins Without a Pull-up or Pull-down	Low	$I_{IL}$	$GND < V_{IN} < V_{IL}$	-10	—	—	$\mu\text{A}$
		High	$I_{IH}$	$V_{IH} < V_{IN} < V_{DD}$	—	—	10	$\mu\text{A}$
	Pins with a Pull-up	Low	$I_{IL}$	$GND < V_{IN} < V_{IL}$	-120	—	-2	$\mu\text{A}$
		High	$I_{IH}$	$V_{IH} < V_{IN} < V_{DD}$	—	—	10	$\mu\text{A}$
	Pins with a Pull-down	Low	$I_{IL}$	$GND < V_{IN} < V_{IL}$	-10	—	—	$\mu\text{A}$
		High	$I_{IH}$	$V_{IH} < V_{IN} < V_{DD}$	2	—	120	$\mu\text{A}$
Output Current in High-impedance State	—	$I_{OZ}$	UPDO, SDX $-40\text{ }^\circ\text{C}$ to $0\text{ }^\circ\text{C}$	-30	—	30	$\mu\text{A}$	
			UPDO, SDX $0\text{ }^\circ\text{C}$ to $85\text{ }^\circ\text{C}$	-10	—	10	$\mu\text{A}$	

Table 9. Analog Interface

Parameter	Symbol	Test Conditions	Min	Typ	Max	Unit
Input Resistance	RVTX	$0.25\text{ V} < V_{TX} < 4.75\text{ V}$	10	—	—	$\text{M}\Omega$
Input Resistance (dependent on the setting of the termination impedance)	RVRTX	$2.3\text{ V} < V_{RTX} < 2.5\text{ V}$	7	—	—	$\text{k}\Omega$
Common-mode Reference Voltage	VVRTX	—	2.2	2.4	2.6	V
CMT Input Sink Current	IVRTX	$2.3\text{ V} < V_{RTX} < 2.5\text{ V}$	—	—	400	$\mu\text{A}$
Input Voltage Swing	VVTX	—	—	—	3.2	Vp-p
Load Resistance at VRP and VRN (differential)	RL	—	4.0	—	—	$\text{k}\Omega$
Load Capacitance	CL	CL from VRP or VRN to $V_{SSA}$	—	—	100	pF
Output Resistance	RO	Digital input code corresponding to 0 dBm PCM code at 1.02 kHz	—	2	10	$\Omega$
Output Offset Voltage Between VRP and VRN	VOS	Digital pattern corresponding to idle PCM code ( $\mu$ -law)	-100	0	100	mV
Output Offset Voltage Between VRP and VRN, Powerdown	VOSPD	Channel powered down 10 $\mu\text{A}$ max dc load	-20	0	20	mV
Output Voltage Swing (differential)	VRSW	RL = 100 $\text{k}\Omega$ differential maximum receive gain	5.28	—	—	Vp-p



## Electrical Characteristics (continued)

### dc Characteristics (continued)

**Table 10. T7536 Power Dissipation**

Parameter	Symbol	Test Conditions	Min	Typ	Max	Unit
Powerdown Current	IDD0	OSCK and OSFS present, 8 channels powered down	—	9	12	mA
Powerup Current	IDD1	OSCK and OSFS present, 8 channels powered up, normal operation	—	61	88	mA

**Table 11. T7531A Power Dissipation**

Parameter	Symbol	Test Conditions	Min	Typ	Max	Unit
Powerdown Current	IDD0	SCK and SFS present, 16 channels powered down and inactive	—	105	—	mA
Powerup Current	IDD1	SCK and SFS present, 16 channels powered up and active	—	175*	190	mA

\* Powerup current exhibits a negative temperature coefficient.

## Transmission Characteristics

**Table 12. Gain and Dynamic Range**

Parameter	Symbol	Test Conditions	Min	Typ	Max	Unit
Absolute Levels	GAL	Maximum 0 dBm0 levels (1.02 kHz): VTX (encoder milliwatt)	—	2.23	—	Vp-p
		(T7536 TX gain = 0 dB; T7531A gain = -1.65 dB)	—	4.38	—	Vp-p
		VRP—VRN (decoder milliwatt)	—	—	—	—
		(T7536 RX gain = 6.02 dB; T7531A gain = 0.21 dB) Termination impedance off	—	—	—	—
Absolute Levels	GAL	Minimum 0 dBm0 levels (1.02 kHz): VTX	—	557.0	—	mVp-p
		(T7536 TX gain = 12.04 dB; T7531A gain = -1.65 dB)	—	548.0	—	mVp-p
		VRP—VRN	—	—	—	—
		(T7536 RX gain = -12.04 dB; T7531A gain = 0.21 dB) Termination impedance off	—	—	—	—
Transmit Gain Absolute Accuracy	GXA	Transmit gain programmed for maximum 0 dBm0 test level, measured deviation of digital code from ideal 0 dBm0 level at OSDX[1:0] digital outputs, with transmit gain set to 0 dB:				
		0 °C to 85 °C	-0.25	—	0.25	dB
		-40 °C to +85 °C	-0.30	—	0.30	dB
Transmit Gain Variation with Programmed Gain	GXAG	Measured transmit gain over the range from maximum to minimum, calculated deviation from the programmed gain relative to GXA at 0 dB: V <sub>DD</sub> = 5 V	-0.1	—	0.1	dB

Transmission Characteristics (continued)

Table 12. Gain and Dynamic Range (continued)

Parameter	Symbol	Test Conditions	Min	Typ	Max	Unit
Transmit Gain Variation with Frequency	GXAF	Relative to 1016 Hz, minimum gain < GX < maximum gain, VTX = 0 dBm0 signal, Tz = 600 Ω, path gain set to 0 dB:				
		f = 16.67 Hz	—	-50	-30	dB
		f = 40 Hz	—	-38	-26	dB
		f = 50 Hz	—	-44	-30	dB
		f = 60 Hz	—	-45	-30	dB
		f = 200 Hz	-1.8	-0.5	0	dB
		f = 300 Hz to 3000 Hz	-0.125	±0.04	0.125	dB
		f = 3140 Hz	-0.57	0.01	0.125	dB
		f = 3380 Hz	-0.735	-0.550	0.015	dB
f = 3860 Hz	—	-9.9	-8.98	dB		
f = 4600 Hz and above	—	—	-32	dB		
Transmit Gain Variation with Signal Level	GXAL	Sinusoidal test method reference level = 0 dBm0:				
		VTX = -37 dBm0 to +3 dBm0	-0.25	—	0.25	dB
		VTX = -50 dBm0 to -37 dBm0	-0.50	—	0.50	dB
VTX = -55 dBm0 to -50 dBm0	-1.4	—	1.4	dB		
Receive Gain Absolute Accuracy	GRA	Receive gain programmed to 0 dB, apply 0 dBm0 oversampled data to OSDRO or OSDR1, measure VRP, RL = 100 kΩ differential: 0 to 85 °C -40 °C to +85 °C	-0.25	—	0.25	dB
			-0.30	—	0.30	dB
Relative Gain: VRP to VRN	—	Digital input 0 dBm0 signal f = 300 Hz to 3400 Hz	-0.01	—	0.01	dB
Relative Phase: VRP to VRN	—	Digital input 0 dBm0 signal f = 300 Hz to 3400 Hz	-0.25	—	0.25	Deg
Receive Gain Variation with Programmed Gain	GRAG	Measure receive gain over the range from maximum to minimum setting, calculated deviation from the programmed gain relative to GRA at 0 dB, VDD = 5 V	-0.1	—	0.1	dB
Receive Gain Variation with Frequency	GRAF	Relative to 1016 Hz, digital input = 0 dBm0 code, minimum gain < GR < maximum gain: 0 dB path gain				
		f = below 3000 Hz	-0.125	±0.04	0.125	dB
		f = 3140 Hz	-0.57	±0.04	0.125	dB
		f = 3380 Hz	-0.735	-0.550	0.015	dB
		f = 3860 Hz	—	-10.7	-8.98	dB
f = 4600 Hz and above	—	—	-28	dB		
Receive Gain Variation with Signal Level	GRAL	Sinusoidal test method, reference level = 0 dBm0:				
		OSDR = -37 dBm0 to +3 dBm0	-0.25	—	0.25	dB
OSDR = -50 dBm0 to -37 dBm0	-0.50	—	0.50	dB		
Relative Termination Impedance Gain	AT	—	-0.2	—	0.2	dB

**Transmission Characteristics** (continued)

**Table 13. Noise (per Channel)**

Parameter	Symbol	Test Conditions	Min	Typ	Max	Unit
Transmit Noise, C-message Weighted	NXC	0 dB transmit gain	—	—	18	dBrnC0
Transmit Noise, P-message Weighted	NXP	0 dB transmit gain	—	—	-68	dBm0p
Receive Noise, C-message Weighted	NRC	0 dB receive gain, digital pattern corresponding to idle PCM code, $\mu$ -law	—	—	13	dBrnC0
Receive Noise, P-message Weighted	NRP	0 dB receive gain, digital pattern corresponding to idle PCM code, $\mu$ -law	—	—	-75	dBm0p
Noise, Single Frequency	NRS	f = 0 kHz to 100 kHz, loop around measurement, VTX = 0 Vrms	—	—	-53	dBm0
Power Supply Rejection, Transmit	PSRX	VDD = 5.0 Vdc + 100 mVrms f = 0 kHz to 4 kHz f = 4 kHz to 50 kHz* C-message weighted	36 30	— —	— —	dB dB
Power Supply Rejection, Receive	PSRR	Measured on VRP VDD = 5.0 Vdc + 100 mVrms f = 0 kHz to 4 kHz f = 4 kHz to 25 kHz f = 25 kHz to 50 kHz Digital pattern corresponding to idle PCM code, $\mu$ -law, C-message weighted	36 40 36	— — —	— — —	dB dB dB
Spurious Out-of-band Signals at the Channel Outputs	SOS	0 dBm0, 300 Hz to 3400 Hz input oversampled data code applied at OSDRO (or OSDR1): 4600 Hz to 7600 Hz 7600 Hz to 8400 Hz 8400 Hz to 50 kHz	— — —	— — —	-30 -40 -30	dB dB dB

\* Measured with a -50 dBm0 activation signal applied to VFXI input of channel under test.

**Transmission Characteristics** (continued)

**Table 14. Distortion and Group Delay**

Parameter	Symbol	Test Conditions	Min	Typ	Max	Unit
Signal to Total Distortion Transmit or Receive C-message Weighted	STD <sub>X</sub> STD <sub>R</sub>	Sinusoidal test method level: 3.0 dBm0 0 dBm0	33 36	— —	— —	dB dB
Single Frequency Distortion, Transmit	SFD <sub>X</sub>	0 dBm0 single frequency input, 200 Hz ≤ f <sub>IN</sub> ≤ 3400 Hz; measure at any other single frequency	—	—	-46	dB
Single Frequency Distortion, Receive	SFD <sub>R</sub>	0 dBm0 single frequency input, 200 Hz ≤ f <sub>IN</sub> ≤ 3400 Hz; measure at any other single frequency	—	—	-46	dB
Intermodulation Distortion	IMD	Transmit or receive, two frequencies in the range (300 Hz to 3400 Hz)	—	—	-41	dB
TX Group Delay, Absolute	D <sub>XA</sub>	f = 1600 Hz, SCK = 4.096 MHz, bit offset = 419	—	250*	300	μs
RX Group Delay, Absolute	D <sub>RA</sub>	f = 1600 Hz	—	250	300	μs

\* Varies as a function of bit offset.

**Table 15. Crosstalk**

Parameter	Symbol	Test Conditions	Min	Typ	Max	Unit
Transmit to Transmit Crosstalk, 0 dBm0 Level	CT <sub>X-X</sub>	f = 300 Hz to 3400 Hz, Any channel to any channel	—	—	-75	dB
Transmit to Receive Crosstalk, 0 dBm0 Level	CT <sub>X-R</sub>	f = 300 Hz to 3400 Hz, Any channel to any other channel In-channel	— —	— —	-75 -50	dB dB
Receive to Transmit Crosstalk, 0 dBm0 Level	CT <sub>R-X</sub>	f = 300 Hz to 3400 Hz, Any channel to any other channel In-channel	— —	— —	-75 -50	dB dB
Receive to Receive Crosstalk, 0 dBm0 Level	CT <sub>R-R</sub>	f = 300 Hz to 3400 Hz, Any channel to any channel	—	—	-75	dB

## Timing Characteristics

A signal is valid if it is above  $V_{IH}$  or below  $V_{IL}$  and invalid if it is between  $V_{IL}$  and  $V_{IH}$ . For the purposes of this specification, the following conditions apply:

- All input signals are defined as  $V_{IL} = 0.4\text{ V}$ ,  $V_{IH} = 2.7\text{ V}$ ,  $t_R < 10\text{ ns}$ ,  $t_F < 10\text{ ns}$ .
- $t_R$  is measured from  $V_{IL}$  to  $V_{IH}$ .  $t_F$  is measured from  $V_{IH}$  to  $V_{IL}$ .
- Delay times are measured from the input signal valid to the output signal valid.
- Setup times are measured from the data input valid to the clock input invalid.
- Hold times are measured from the clock signal valid to the data input invalid.
- Pulse widths are measured from  $V_{IL}$  to  $V_{IL}$  or from  $V_{IH}$  to  $V_{IH}$ .

**Table 16. PCM Interface Timing** (See Figure 9.)

Symbol	Parameter	Test Conditions	Min	Typ	Max	Unit
fSCK	Frequency of SCK (Selection frequency is pin-strap programmable.)	—	— —	2.048 4.096	— —	MHz MHz
tSCK	Period of SCK	Measured from $V_{IL}$ to $V_{IL}$	—	1/fSCK	—	ns
—	Jitter of SCK	—	—	—	100 ns in 100 ms = 1 ppm	—
tSCHSCL	Period of SCK High	Measured from $V_{IH}$ to $V_{IH}$	80	—	—	ns
tSCLSCH	Period of SCK Low	Measured from $V_{IL}$ to $V_{IL}$	80	—	—	ns
tSCH1SCH2	Rise Time of SCK	Measured from $V_{IL}$ to $V_{IH}$	—	—	15	ns
tSCL2SCL1	Fall Time of SCK	Measured from $V_{IH}$ to $V_{IL}$	—	—	15	ns
tFSHFSL	Period of SFS High	Measured from $V_{IH}$ to $V_{IL}$ : 2.048 MHz 4.096 MHz	0.488 0.244	— —	62.5 62.5	$\mu\text{s}$ $\mu\text{s}$
tSFHSCL	Frame Sync High Setup	—	30	—	—	ns
tSCLSFL	Frame Sync Hold Time	—	30	—	—	ns
tSCHDXV	Data Enabled on TS Entry	$0 < C_{LOAD} < 100\text{ pF}$	0	9	90	ns
tDRV SCL	Receive Data Setup	—	30	—	—	ns
tSCLDRX	Receive Data Hold	—	30	—	—	ns

Timing Characteristics (continued)

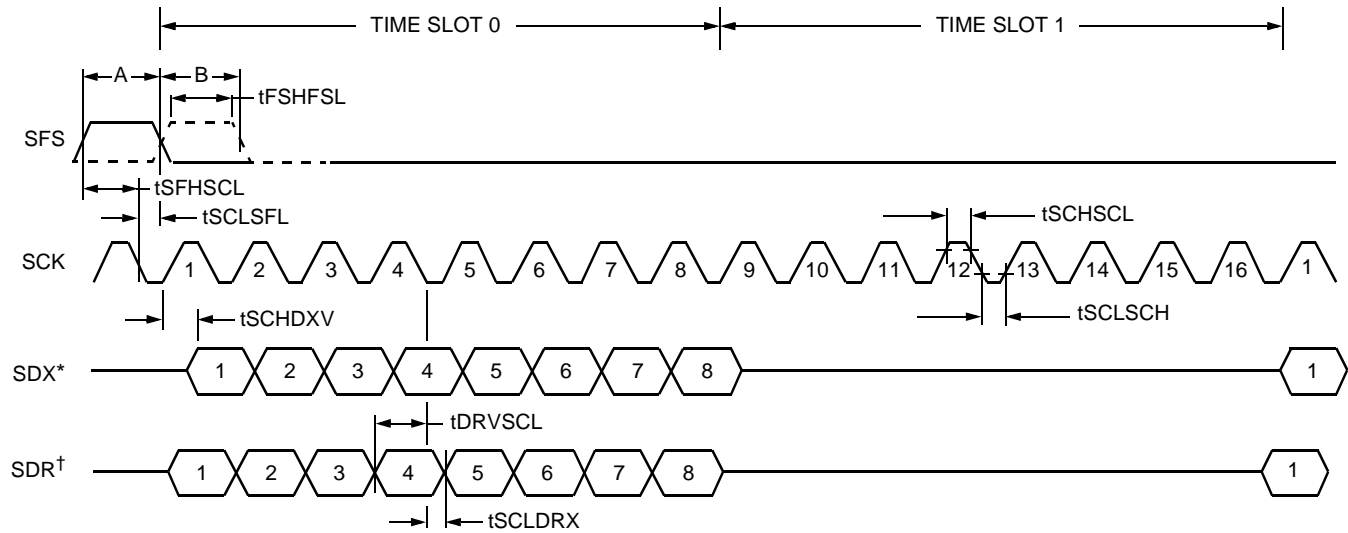

5-4233.a (F)

\* Card address 0, bit offset 0 assumed.

† Card address 0 assumed.

Notes:

A is the position of the frame sync pulse in the delayed mode.

B is the position of the frame sync pulse in the nondelayed mode.

Figure 9. Timing Characteristics of PCM Interface Assuming 2.048 MHz SCK Rate

**Timing Characteristics** (continued)

**Table 17. Serial Control Port Timing** (See Figure 10.)

Symbol	Parameter	Test Conditions	Min	Typ	Max	Unit
tCSHLSET	$\overline{\text{UPCS}}$ to UPCK Setup	—	25	—	—	ns
tCSLHHOD	$\overline{\text{UPCS}}$ to UPCK Hold	—	20 ns	—	UPCK Period/2	—
tUPDIST	UPDI to UPCK Setup	—	25	—	—	ns
tUPDIHD	UPDI to UPCK Hold	—	20	—	—	ns
tUPDODEL	UPCK to UPDO Delay	CL = 50 pF	—	—	42	ns
tUPDOHZDL	$\overline{\text{UPCS}}$ to UPDO High-Z	CL = 50 pF	—	—	34	ns
tCKCSH	Duration of UPCK and $\overline{\text{UPCS}}$ High: Write Cycle Read Cycle	—	1	—	—	$\mu\text{s}$
		—	9	—	—	$\mu\text{s}$
tCKCSH1	Duration of UPCK and $\overline{\text{UPCS}}$ High	—	9	—	—	$\mu\text{s}$

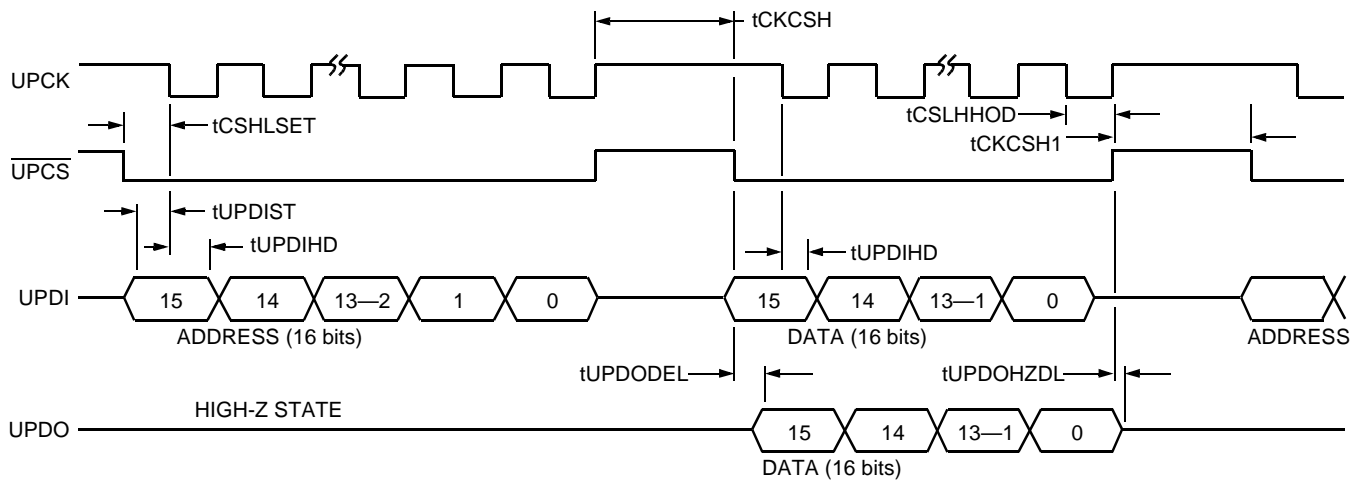

5-4232a (F)

Notes:

$\overline{\text{UPCS}}$  and UPDI change at the rising edge of UPCK by the microprocessor and are sampled at the falling edge of UPCK by the DSP.  
UPDO changes at the rising edge of UPCK by the DSP and is sampled at the falling edge of UPCK by the microprocessor.

**Figure 10. Timing Diagram for Microprocessor Write/Read to/from the DSP on the Control Interface**

## Software Interface

Table 18 lists the RAM data space for the DSP engine. Space for up to 16 channels is allocated. The total T7531A RAM size is 2 Kwords, arranged as 2 x 1 Kbanks. Address bit 15 is used as a read/write flag (1 = read). The micro-processor interface can read any address in the DSP engine RAM space.

**Table 18. DSP Engine RAM Memory Map**

Address Range	Memory Contents	Write by Microprocessor Interface
<b>RAM Bank 0</b>	<b>Time-Slot Information Tables</b> (See page 17.)	
0x0000	Time-slot control word (time slot 0)	Y
0x0001 <sup>1</sup>	Receive ac routine address (time slot 0)	Y
0x0002 <sup>1</sup>	Transmit ac routine address (time slot 0)	Y
0x0003—0x003F	Data storage (time slot 0)	Selected locations
0x0040 <sup>2</sup>	Time slot 1 information table	As shown for time slot 0
0x0080	Time slot 2 information table	As shown for time slot 0
0x00C0	Time slot 3 information table	As shown for time slot 0
0x0100	Time slot 4 information table	As shown for time slot 0
0x0140	Time slot 5 information table	As shown for time slot 0
0x0180	Time slot 6 information table	As shown for time slot 0
0x01C0	Time slot 7 information table	As shown for time slot 0
0x0200	Time slot 8 information table	As shown for time slot 0
0x0240	Time slot 9 information table	As shown for time slot 0
0x0280	Time slot 10 information table	As shown for time slot 0
0x02C0	Time slot 11 information table	As shown for time slot 0
0x0300	Time slot 12 information table	As shown for time slot 0
0x0340	Time slot 13 information table	As shown for time slot 0
0x0380	Time slot 14 information table	As shown for time slot 0
0x03C0	Time slot 15 information table	As shown for time slot 0
<b>RAM Bank 1</b>	<b>ac Coefficient Reference Tables</b> (See page 16.)	
0x0400—0x040F	Channel coefficient address table	N
0x0410—0x0413	Default coefficient address table	N
0x0414—0x0434	Reserved	N
<b>ac Per-Channel Coefficients</b> (See page 16.)		
0x0435	Receive path relative gain (channel 0)	Y
0x0436	Data storage (channel 0)	N
0x0437	Receive path absolute gain (channel 0)	Y
0x0438	Transmit path absolute gain (channel 0)	Y
0x0439—0x0442	Balance filter coefficients (channel 0)	Y
0x0443	Data storage (channel 0)	N
0x0444	Transmit path relative gain (channel 0)	Y

1. The receive and transmit ac routine addresses are the only addresses that can address ROM code.

2. For time slots 1—15, the address shown is the first address. Refer to time slot 0 for range information.



**Software Interface** (continued)

**Table 18. DSP Engine RAM Memory Map** (continued)

Address Range	Memory Contents	Write by Microprocessor Interface
0x0445 <sup>3</sup>	Channel 1 ac filter coefficients	As shown for channel 0
0x0455	Channel 2 ac filter coefficients	As shown for channel 0
0x0465	Channel 3 ac filter coefficients	As shown for channel 0
0x0475	Channel 4 ac filter coefficients	As shown for channel 0
0x0485	Channel 5 ac filter coefficients	As shown for channel 0
0x0495	Channel 6 ac filter coefficients	As shown for channel 0
0x04A5	Channel 7 ac filter coefficients	As shown for channel 0
0x04B5	Channel 8 ac filter coefficients	As shown for channel 0
0x04C5	Channel 9 ac filter coefficients	As shown for channel 0
0x04D5	Channel 10 ac filter coefficients	As shown for channel 0
0x04E5	Channel 11 ac filter coefficients	As shown for channel 0
0x04F5	Channel 12 ac filter coefficients	As shown for channel 0
0x0505	Channel 13 ac filter coefficients	As shown for channel 0
0x0515	Channel 14 ac filter coefficients	As shown for channel 0
0x0525	Channel 15 ac filter coefficients	As shown for channel 0
<b>ac Per-Board<sup>4</sup> Coefficients</b>		
0x0535—0x053E	Receive filter coefficients	Y
0x053F—0x0552	Transmit (equalizer) filter coefficients	Y
0x0553	Transmit gain coefficients for filter compensation	Y
0x0554—0x0560	Unused	Y
<b>Default Per-Board<sup>4</sup> Coefficient Tables</b>		
0x0561	Default Table 1 receive path relative gain	Y
0x0562	Default Table 1 receive path absolute gain	Y
0x0563	Default Table 1 transmit path absolute gain	Y
0x0564—0x056D	Default Table 1 balance filter coefficients	Y
0x056E	Default Table 1 transmit path relative gain	Y
0x056F—0x057C	Default Table 2 coefficient set	Y
<b>Self-Test Flags</b>		
0x057D—0x05EE	Temporary storage for self-test routines	Y
0x05EF—0x07EF	Unused	Y
0x07F0	Result of ROM checksum test	N
0x07F2	Result of RAM checksum test	N
0x07F4	Result of TX path self-test	N
0x07F5	Result of RX path self-test	N
0x07F6	ROM code version number	N

1. The receive and transmit ac routine addresses are the only addresses that can address ROM code.
2. For time slots 1—15, the address shown is the first address. Refer to time slot 0 for range information.
3. For channels 1—15, the address shown is the first address. Refer to channel 0 for range information.
4. Per-board refers to a function that is common to all 16 channels in a single chip set.

**Software Interface** (continued)

**Table 19. T7531A Time-Slot Assignment Memory Map**

All registers can be written by the microprocessor interface.

Address Range	Memory Contents
0x1400	Time slot 0 channel assignment
0x1401	Time slot 1 channel assignment
0x1402	Time slot 2 channel assignment
0x1403	Time slot 3 channel assignment
0x1404	Time slot 4 channel assignment
0x1405	Time slot 5 channel assignment
0x1406	Time slot 6 channel assignment
0x1407	Time slot 7 channel assignment
0x1408	Time slot 8 channel assignment
0x1409	Time slot 9 channel assignment
0x140A	Time slot 10 channel assignment
0x140B	Time slot 11 channel assignment
0x140C	Time slot 12 channel assignment
0x140D	Time slot 13 channel assignment
0x140E	Time slot 14 channel assignment
0x140F	Time slot 15 channel assignment

**Table 20A. Bit Map for T7531A Time-Slot Assignment Registers at 0x1400—0x140F**

Bit Number and Function						
15—6	5	4	3	2	1	0
Not used	CTZ disable	Null channel	Binary-coded channel number 0—15			

**Table 20B. Bit Map for CTZ Disable and Null Channel**

Bit 5	Bit 4	Function
X	0	Disables null pointer
X	1	Nulls channel
0	X	Enables CTZ
1	X	Disables CTZ

Notes:

X = Don't care.

Bits 4 and 5 default to 1 upon reset.

**Software Interface** (continued)

**Table 21. T7531A Channel Register Memory Map for T7536 Device 0**

All registers can be written by the microprocessor interface.

Address Range	Memory Contents
0x1500	Channel 0 powerup/powerdown register
0x1501	Channel 1 powerup/powerdown register
0x1502	Channel 2 powerup/powerdown register
0x1503	Channel 3 powerup/powerdown register
0x1504	Channel 4 powerup/powerdown register
0x1505	Channel 5 powerup/powerdown register
0x1506	Channel 6 powerup/powerdown register
0x1507	Channel 7 powerup/powerdown register
0x1508	Channel 0 control register 1
0x1509	Channel 1 control register 1
0x150A	Channel 2 control register 1
0x150B	Channel 3 control register 1
0x150C	Channel 4 control register 1
0x150D	Channel 5 control register 1
0x150E	Channel 6 control register 1
0x150F	Channel 7 control register 1
0x1510	All channel test register
0x1517	Single-byte soft reset (no data word)
0x1518	Channel 0 control register 2
0x1519	Channel 1 control register 2
0x151A	Channel 2 control register 2
0x151B	Channel 3 control register 2
0x151C	Channel 4 control register 2
0x151D	Channel 5 control register 2
0x151E	Channel 6 control register 2
0x151F	Channel 7 control register 2

**Table 22. T7531A Channel Register Memory Map for T7536 Device 1**

All registers can be written by the microprocessor interface.

Address Range	Memory Contents
0x1540	Channel 8 powerup/powerdown register
0x1541	Channel 9 powerup/powerdown register
0x1542	Channel 10 powerup/powerdown register
0x1543	Channel 11 powerup/powerdown register
0x1544	Channel 12 powerup/powerdown register
0x1545	Channel 13 powerup/powerdown register
0x1546	Channel 14 powerup/powerdown register
0x1547	Channel 15 powerup/powerdown register
0x1548	Channel 8 control register 1
0x1549	Channel 9 control register 1
0x154A	Channel 10 control register 1
0x154B	Channel 11 control register 1
0x154C	Channel 12 control register 1
0x154D	Channel 13 control register 1
0x154E	Channel 14 control register 1
0x154F	Channel 15 control register 1
0x1550	All channel test register
0x1557	Single-byte soft reset (no data word)
0x1558	Channel 8 control register 2
0x1559	Channel 9 control register 2
0x155A	Channel 10 control register 2
0x155B	Channel 11 control register 2
0x155C	Channel 12 control register 2
0x155D	Channel 13 control register 2
0x155E	Channel 14 control register 2
0x155F	Channel 15 control register 2

**Table 23. Bit Map for T7536 Powerup/Powerdown Registers at 0x1500—0x1507 and 0x1540—0x1547**

Bit Number and Function	
15	14—0
PWR	Not used

Notes:

PWR = 0: powerdown.

PWR = 1: powerup—normal operation.

**Software Interface** (continued)

**Table 24. Bit Map for T7536 Channel Control Register 1 at 0x1508—0x150F and 0x1548—0x154F**

Bit Number and Function									
15	14—8	7	6	5	4	3	2	1	0
PWR	Not used	TX gain			Termination impedance				LPBK

**Table 25. T7536 Control Register 1: Transmit Gain**

Bit 7	Bit 6	Bit 5	Mode
TXGAIN2	TXGAIN1	TXGAIN0	
0	0	0	0 dB transmit gain
0	0	1	3.01 dB transmit gain
0	1	0	6.02 dB transmit gain
0	1	1	9.03 dB transmit gain
1	0	0	12.04 dB transmit gain
1	0	1	12.04 dB transmit gain
1	1	0	12.04 dB transmit gain
1	1	1	12.04 dB transmit gain

**Table 26. T7536 Control Register 1: Analog Termination Impedance**

Bit 4	Bit 3	Bit 2	Bit 1	Gain (See equation on page 12.)	Analog Termination Impedance ( $\Omega$ )
TI3	TI2	TI1	TI0		
0	0	0	0	0.0000	165*
0	0	0	1	0.0583	200
0	0	1	0	0.1417	250
0	0	1	1	0.2250	300
0	1	0	0	0.3083	350
0	1	0	1	0.3917	400
0	1	1	0	0.5000	465
0	1	1	1	0.5583	500
1	0	0	0	0.6417	550
1	0	0	1	0.7083	600
1	0	1	0	0.8083	650
1	0	1	1	0.8917	700
1	1	0	0	0.9750	750
1	1	0	1	1.0583	800
1	1	1	0	1.2167	895
1	1	1	1	2.0000	1365

\* This value is equivalent to the protection resistor value multiplied by 2.

**Software Interface** (continued)

**Table 27. T7536 Control Register 1: Digital Loopback**

Bit 0	Mode
LPBK	
0	Normal operation
1	Digital loopback

**Table 28. Bit Map for T7536 All Channel Test Register at 0x1510 and 0x1550**

Bit Number and Function				
15—4	3	2	1	0
Not used	Read out address	Reserved	Analog loopback	Digital loopback

**Table 29. Bits 3:0 of T7536 All Channel Test Register at 0x1510 and 0x1550**

Bit Number				Function
3	2	1	0	
0	—	—	—	Normal operation
1	—	—	—	Read out address
—	0	—	—	Reserved
—	1	—	—	Normal operation
—	—	0	—	Normal operation
—	—	1	—	Analog loopback
—	—	—	0	Normal operation
—	—	—	1	Digital loopback

Notes:

Read out address provides the previous read or write address to CDO whenever a new address is being written into the register.

When analog loopback is high, data that enters the analog transmit path (VTX) is converted to a 1.024 MHz digital bit stream and routed back to the analog receive path (VRP, VRN). The output of the transmit path is available on the oversampled data interface, but receive path oversampled data is ignored.

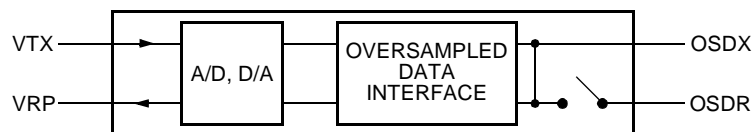

5-5134 (F)

When digital loopback is high, oversampled data receive (OSDR) is routed to oversampled data transmit (OSDX). The receive signal is propagated to VRN/VRP, but any transmit signal from VTX is disconnected. A reference voltage on VRTX is still required in this mode.

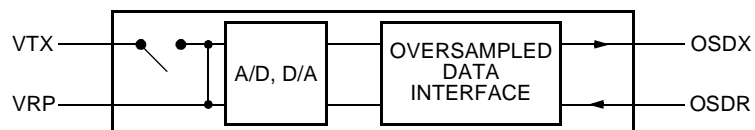

5-5135 (F)

**Software Interface** (continued)

**Table 30. Bit Map for T7536 Channel Control Register 2 at 0x1518—0x151F and 0x1558—0x155F**

Bit Number and Function					
15—8	7	6—3	2	1	0
Not used	SUSEQ	Not used		Receive gain	

Notes:

SUSEQ = 0: normal operation.

SUSEQ = 1: start-up calibration sequence.

**Table 31. T7536 Control Register 2: Receive Gain**

Bit 2	Bit 1	Bit 0	Mode TLP Levels, Termination Impedance Is On
RXGAIN2	RXGAIN1	RXGAIN0	
0	0	0	6.02 dB receive gain
0	0	1	3.01 dB receive gain
0	1	0	0.0 dB receive gain
0	1	1	-3.01 dB receive gain
1	0	0	-6.02 dB receive gain
1	0	1	-9.03 dB receive gain
1	1	0	-12.04 dB receive gain
1	1	1	-12.04 dB receive gain

**Table 32. T7531A Control Register Map**

Address Range	Register Contents	Write by Microprocessor Interface
0x1FFE	Board control word 1	Y
0x1FFC	Board control word 2	Y
0x1FFA	Board control word 3	Y
0x1FF8	Board control word 4	Y
0x1FF6	Board control word 5	Y

Note: A board control word controls a function that is common to all 16 channels of a given chip set.

**Software Interface** (continued)

**Table 33. Bits 15:8 of T7531A Board Control Word 1 at 0x1FFE**

Bit Number								Function
15	14	13	12	11	10	9	8	
0	—	—	—	—	—	—	—	Normal operation
1	—	—	—	—	—	—	—	Soft reset
—	—	—	—	0	—	—	—	Normal operation
—	—	—	—	1	—	—	—	TZ test mode
—	—	—	—	—	0	—	—	Normal operation
—	—	—	—	—	1	—	—	RX dither circuit off
—	—	—	—	—	—	0	—	Normal operation
—	—	—	—	—	—	1	—	Nodecim test mode
—	—	—	—	—	—	—	0	Normal operation
—	—	—	—	—	—	—	1	Linear mode

**Table 34. Bits 7:0 of T7531A Board Control Word 1 at 0x1FFE**

Bit Number								Function
7	6	5	4	3	2	1	0	
0	X	—	—	—	—	—	—	Delayed data timing
1	X	—	—	—	—	—	—	Nondelayed data timing
—	X	0	x	—	—	—	—	$\mu$ -law
—	X	1	0	—	—	—	—	A-law, including even bit inversion
—	X	1	1	—	—	—	—	A-law, no even bit inversion
—	X	—	—	C1	C0	—	—	C1C0 = card address in binary
—	X	—	—	—	—	0	—	Reserved
—	X	—	—	—	—	1	—	Normal operation
—	X	—	—	—	—	—	0	Normal operation
—	X	—	—	—	—	—	1	Loopback at OSD

Notes:

All bits in board control register 1 will be zeros upon hardware reset.

In OSD loopback mode, OSDR0, OSDR1, OSDR2, and OSDR3 are looped back with a delay of two OSCLK clock cycles to OSDX0, OSDX1, OSDX2, and OSDX3, respectively.

Test modes are for production testing only.

$\mu$ -law/A-law companding mode provides 8 bits of PCM data with the first bit (bit 1) defined as the MSB and the last bit (bit 8) as the LSB. Bit 1 is the sign bit, bits 2 through 4 are the chord bits, and bits 5 through 8 are the interval bits. In linear mode, the  $\mu$ -law/A-law conversion in the PCM interface block is disabled and 16 bits of linear PCM data are provided. In linear mode, bit 1 is the MSB and the sign bit, bits 2 through 14 are the intervals, and bits 15 and 16 are insignificant. Each interval represents 0.0001362745 V<sub>rms</sub> with 8031 intervals being the maximum signal output of 3 dBm0. Negative values are two's complement of positive values.

X = don't care.

**Software Interface** (continued)

**Table 35. Bits 15:9 of T7531A Board Control Word 2 at 0x1FFC**

Bit Number and Function
15—9
Not used

**Table 36. Bits 8:0 of T7531A Board Control Word 2 at 0x1FFC**

Bit Number							Function
8	7	6	5, 4, 3	2	1	0	
BOF8	BOF7	BOF6	BOF5—3	BOF2	BOF1	BOF0	BOF8—0 = Bit offset in binary*

\* The following bit offset values are not valid and should not be used:

When using a 2.048 MHz SCK: bit offset = 0, 16, 32, 48, 64, 80, 96, 112, 128, 144, 160, 176, 192, 208, 224, and 240.

When using a 4.096 MHz SCK: bit offset = 0, 32, 64, 96, 128, 160, 192, 224, 256, 288, 320, 352, 384, 416, 448, 480.

Note: Bits 15 through 9 are not used; assumed to be zeros. BOF[8:0] provide a fixed offset, relative to the frame synchronization strobe (SFS), for the first bit transmitted in each time slot. The offset is the number of data periods by which transmission of the first bit on SDX is delayed. All subsequent transmissions also follow this offset. The default value after hardware reset or powerup is 1A3; however, this register must still be written after reset.

**Table 37. Bits 15:0 of T7531A Board Control Word 3 at 0x1FFA**

Bit Number and Function	
15—5	4—0
Not used	TZ test bits

Note: For test use only, do not use in normal operation. The default value after hardware reset or powerup is 0.

**Table 38. Bits 15:0 of T7531A Board Control Word 4 at 0x1FF8**

Bit Number and Function	
15—10	9—0
Not used	CTZ alpha coefficients

Note: The default value after hardware reset or powerup is A4.

**Table 39. Bits 15:0 of T7531A Board Control Word 5 at 0x1FF6**

Bit Number and Function	
15—8	7—0
Not used	CTZ beta coefficients

Note: The default value after hardware reset or powerup is 0.

**Table 40. Bits 15:0 of T7531A Reset of Microprocessor Commands at 0x7FFF**

Bit Number															Function	
15	14	13	12	11	10	9	8	7	6	5	4	3	2	1		0
1	1	1	1	1	1	1	1	1	1	1	1	1	1	1	1	Clear address and data words in T7531A



## Software Interface (continued)

Table 41 shows the memory map for the DSP engine ROM. The ROM information is not accessible via the micro-processor. The total ROM size is 4 Kwords.

**Table 41. DSP Engine ROM Memory Map**

Address Range	Memory Contents
0x0003	HDS interrupt service routine
0x0008	Time-slot sync interrupt service routine
0x000B	Start-up routine
0x0380	Time segment controller (ts_proc)
0x03B0	Reserved
0x03B8	Reserved
0x0400	Transmit path active routine
0x0500	Receive path active routine
0x0600	Transmit path inactive/loopback routine
0x0610	Transmit path inactive routine
0x0680	Receive path inactive/loopback routine
0x0690	Receive path inactive routine
0x0700	Self-test pass 1 setup (TX)
0x0720	Self-test pass 2 setup (RX)
0x07A0	Tone generation start-up
0x0860	Tone detection start-up
0x0A80	Variance calculation
0x0B00	Peak detection
0x0B60	dc generation
0x0B80	ROM checker
0x0C00	RAM checker
0x0E00	Variance calculation with TX filters
0x0F00	Simultaneous start-up of tone generator and DFT routine
0x0F10	Simultaneous start-up of tone generator and original variance routine
0x0F20	Routine places TX and RX halves of a time slot into inactive loopback
0x0F30	Places TX and RX halves of a time slot into inactive routine
0x0F40	Routine for copying values in channel coefficient table 0 to all 16-channel tables
0x0F60	Approximate location of HDS code
0x0FFE	Checksum for ROM 0x0000 : 0x07FF
0x0FFF	Checksum for ROM 0x0800 : 0x0FFD

## Applications

Figure 11 shows a full line card implementation using the T7531A/T7536 codec and the L7585 SLIC with integrated relays. One T7531A and two T7536 devices support 16 SLIC devices (only one L7585 SLIC is illustrated). Figure 11 portrays only the transmission paths inside the L7585 SLIC. L7585 functionality includes eight solid-state relays, performing ring, test, and break functions, a ring-trip detector, quiet polarity reversal, 13 operating states, and more. For complete functionality of this SLIC, refer to the L7585 data sheet.

The analog connection between the SLIC and the codec is direct; no external components are required. The transfer of control data on the octal interface between the T7531A and T7536 devices is also direct. Data is synchronous with OSCK and transmits at a

4.096 MHz rate. The microprocessor control interface is a standard 4-wire serial port connection, microprocessor clock (UPCK), chip select (UPCS), data input (UPDI), and output (UPDO). The T7531A generates a 16 MHz clock for microprocessor use. This clock is always present. The PCM interface consists of a system clock (SCK) input of either 2.048 MHz or 4.096 MHz, an 8 kHz system frame sync (SFS) input, a system data transmit port (DX), and a system data receive (DR) port. Other than power supply decoupling, the only external components required by the codec chip set are the two 6.8 kΩ resistors and the three 0.1 μF capacitors. These are required by the internal clock synthesizer filter circuit of the T7531A. The clock synthesizer generates a 98.304 MHz master clock for DSP use.

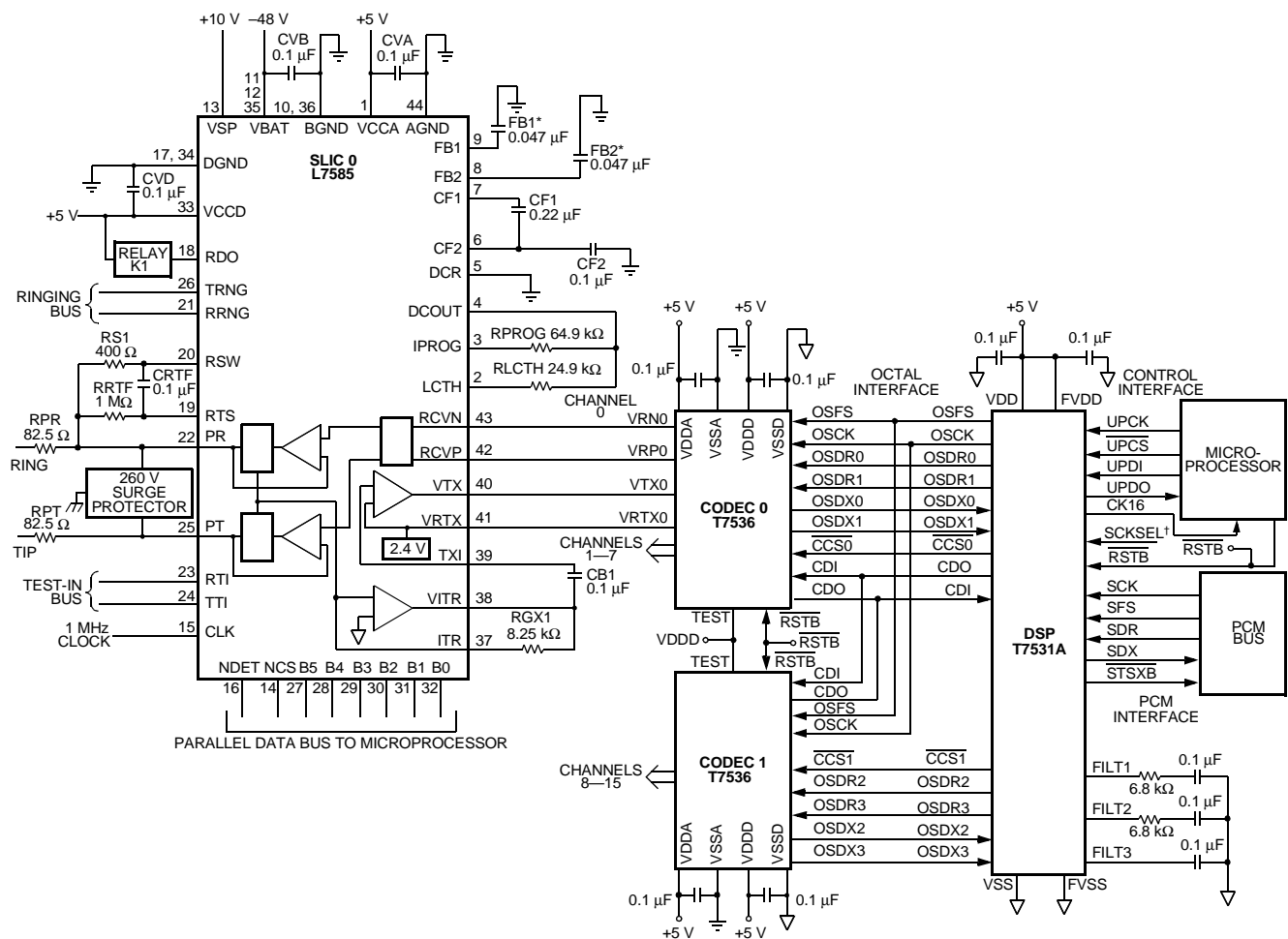

12-3351.d (F)

\* Optional for quiet reverse battery.

† 4.096 MHz operation; for 2.048 MHz operation, tie SCKSEL to Vss.

Figure 11. 16-Channel Line Card Solution

## Outline Diagram

### 68-Pin PLCC

Dimensions are in millimeters. The controlling dimensions are in inches.

**Note:** The dimensions in this outline diagram are intended for informational purposes only. For detailed schematics to assist your design efforts, please contact your Lucent Technologies Sales Representative.

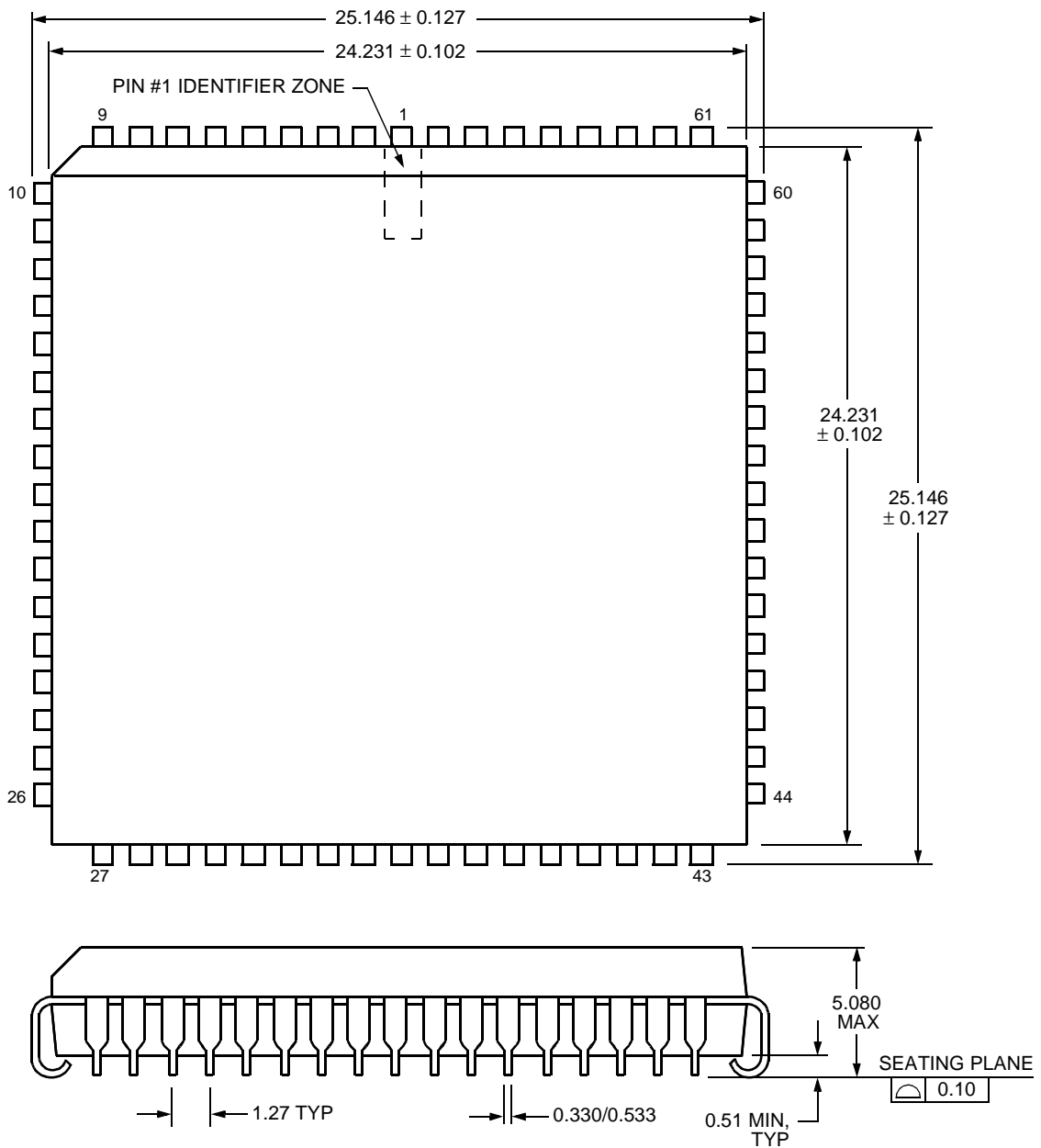

## Ordering Information

Device Code	Package	Temperature	Comcode
T-7531A - - - ML	68-Pin PLCC	-40 °C to +85 °C	107529729
T-7531A - - - ML-TR	68-Pin PLCC	-40 °C to +85 °C	107578627
T-7536 - - - ML	68-Pin PLCC	-40 °C to +85 °C	107393993
T-7536 - - - ML-TR	68-Pin PLCC	-40 °C to +85 °C	107412041

For additional information, contact your Microelectronics Group Account Manager or the following:

INTERNET: <http://www.lucent.com/micro>

E-MAIL: [docmaster@micro.lucent.com](mailto:docmaster@micro.lucent.com)

N. AMERICA: Microelectronics Group, Lucent Technologies Inc., 555 Union Boulevard, Room 30L-15P-BA, Allentown, PA 18103

**1-800-372-2447**, FAX 610-712-4106 (In CANADA: **1-800-553-2448**, FAX 610-712-4106)

ASIA PACIFIC: Microelectronics Group, Lucent Technologies Singapore Pte. Ltd., 77 Science Park Drive, #03-18 Cintech III, Singapore 118256

**Tel. (65) 778 8833**, FAX (65) 777 7495

CHINA: Microelectronics Group, Lucent Technologies (China) Co., Ltd., A-F2, 23/F, Zao Fong Universe Building, 1800 Zhong Shan Xi Road, Shanghai 200233 P. R. China **Tel. (86) 21 6440 0468, ext. 316**, FAX (86) 21 6440 0652

JAPAN: Microelectronics Group, Lucent Technologies Japan Ltd., 7-18, Higashi-Gotanda 2-chome, Shinagawa-ku, Tokyo 141, Japan

**Tel. (81) 3 5421 1600**, FAX (81) 3 5421 1700

EUROPE: Data Requests: MICROELECTRONICS GROUP DATALINE: **Tel. (44) 1189 324 299**, FAX (44) 1189 328 148

Technical Inquiries: GERMANY: **(49) 89 95086 0** (Munich), UNITED KINGDOM: **(44) 1344 865 900** (Ascot),

FRANCE: **(33) 1 40 83 68 00** (Paris), SWEDEN: **(46) 8 594 607 00** (Stockholm), FINLAND: **(358) 9 4354 2800** (Helsinki),

ITALY: **(39) 02 6608131** (Milan), SPAIN: **(34) 1 807 1441** (Madrid)

Lucent Technologies Inc. reserves the right to make changes to the product(s) or information contained herein without notice. No liability is assumed as a result of their use or application. No rights under any patent accompany the sale of any such product(s) or information.

