

TOSHIBA CMOS Digital Integrated Circuit Silicon Monolithic

T6B70BFG

Interface IC for Hot Water Dispensers

The T6B70BFG is designed to be used mainly as an interface IC for communication between hot water dispensers and the corresponding controller unit, and comes equipped with a two channel 4-bit D/A converter, pseudo sine wave generator and an external analog signal detection circuit.

Features

- Built-in two channel 4-bit D/A converter (opposite polarities)
- Built-in pseudo sine wave generator (external clock 1/16 frequency divider)
- Built-in external analog signal detection/non-detection circuit
- Built-in two channel analog switch

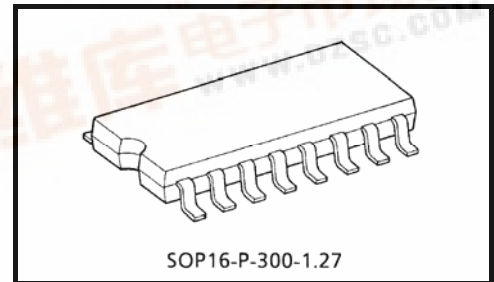

Weight: 0.16 g (typ.)

Block Diagram

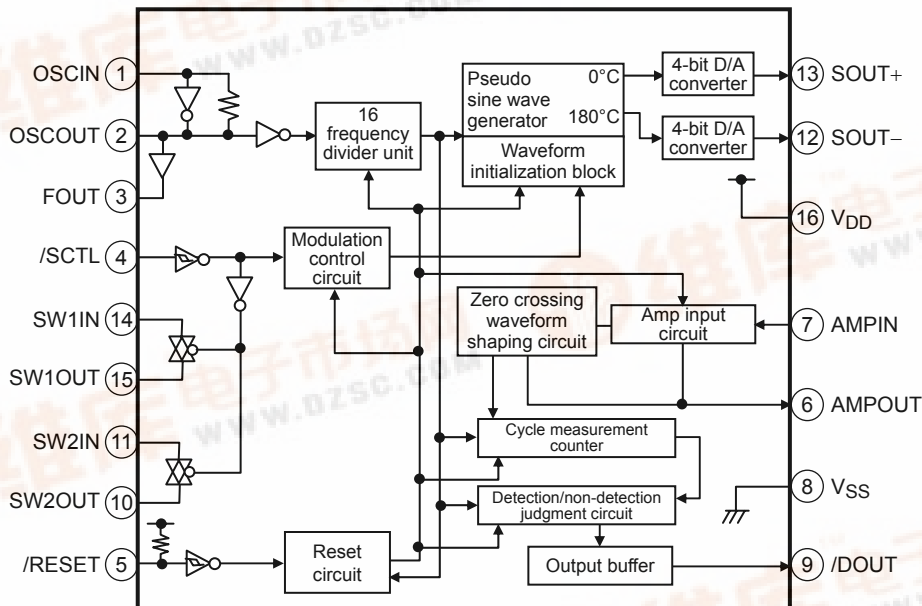

Pin Assignment Diagram

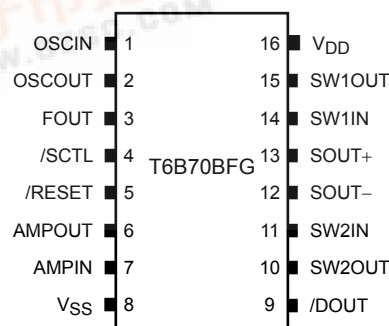

Pin Functions

Pin No.	Symbol	Input/Output	Function
1	OSCIN	Input	Pins connected to oscillation
2	OSCOUT	Output	Pins connected to oscillation
3	FOUT	Output	Output pin for oscillation waveform shaping circuit
4	/SCTL	Input	Modulation control signal input pin
5	/RESET	Input	Reset signal input pin
6	AMPOUT	Output	Amplifier signal output pin
7	AMPIN	Input	Amplifier signal input pin
8	V _{SS}	—	Device ground pin (0 V)
9	/DOUT	Output	Output pin for amplifier input signal detector
10	SW2OUT	Output	Output pin on analog SW2 side
11	SW2IN	Input	Input pin on analog SW2 side
12	SOUT-	Output	Pseudo sine wave (opposite polarity of SOUT + output) output pin
13	SOUT+	Output	Pseudo sine wave output pin
14	SW1IN	Input	Input pin on analog SW1 side
15	SW1OUT	Output	Output pin on analog SW1 side
16	V _{DD}	—	Device power supply pin (+5 V)

The equivalent circuit diagrams provided in the above table are given to facilitate understanding in designing the external circuitry but are not intended to accurately represent the internal circuitry.

Functions

1. Pseudo sine wave generator and 4-bit D/A converters (transmission block)

The pseudo sine wave signal with $F_{osc}/16$ frequency is output from the pseudo sine wave output pins (SOUT+ and SOUT-).

The output polarity of SOUT+ and SOUT- are the opposite.

The transmission block (pseudo sine wave generator and 4-bit D/A converter are as shown below (SOUT+ pin side):

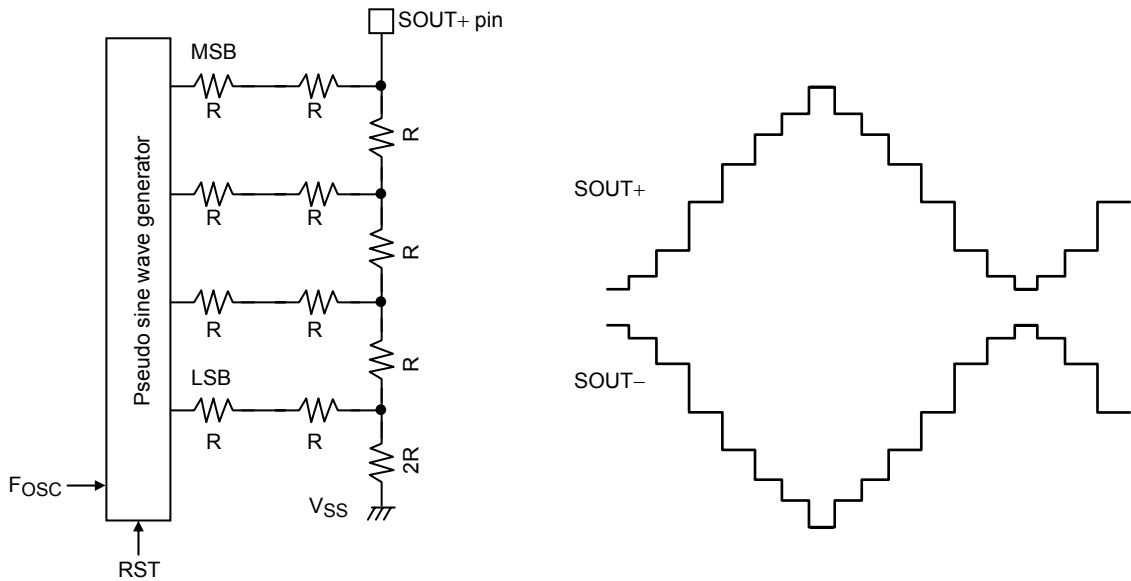

The data of the pseudo sine wave generator is output in the following sequence:
 0 → 1 → 3 → 6 → 9 → C → E → F → F → E → C → 9 → 6 → 3 → 1 → 0 (hexadecimal)

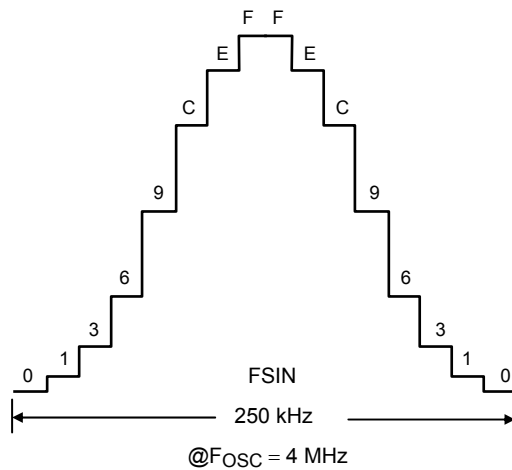

Therefore, when there is no load, the pseudo sine waveform of the positive and negative output is like a staircase (as illustrated above).

An analog switch is built-in so that the driver output buffer connects to the transmission line only during transmission.

However, an emitter follower circuit is externally connected to the driver output buffer.

The phase difference between the positive and negative output is within $180^\circ \pm 5^\circ$ (to account for fluctuation in the pseudo sine wave output phase).

2. Amplifier input circuit and signal detection/non-detection circuit (reception block)

The modulation signal input block is equipped with high and a low comparator to detect only when the external sine wave signal's amplitude is above the defined threshold. In this way, signals with amplitudes lower than the specified threshold (e.g., noise signals) are prevented from being mistakenly detected as sine waves.

The detection frequency range (frequency window) is determined by the divider ratio 1/17 to 1/15 of F_{osc} . Detection/non-detection confirmation conditions are such that when the signals within the specified frequency range are detected (or not detected) in succession, the signals are controlled. It takes about 9 to 15 waves (based on F_{osc} 1/16 frequency) to make detection/non-detection confirmation in this manner.

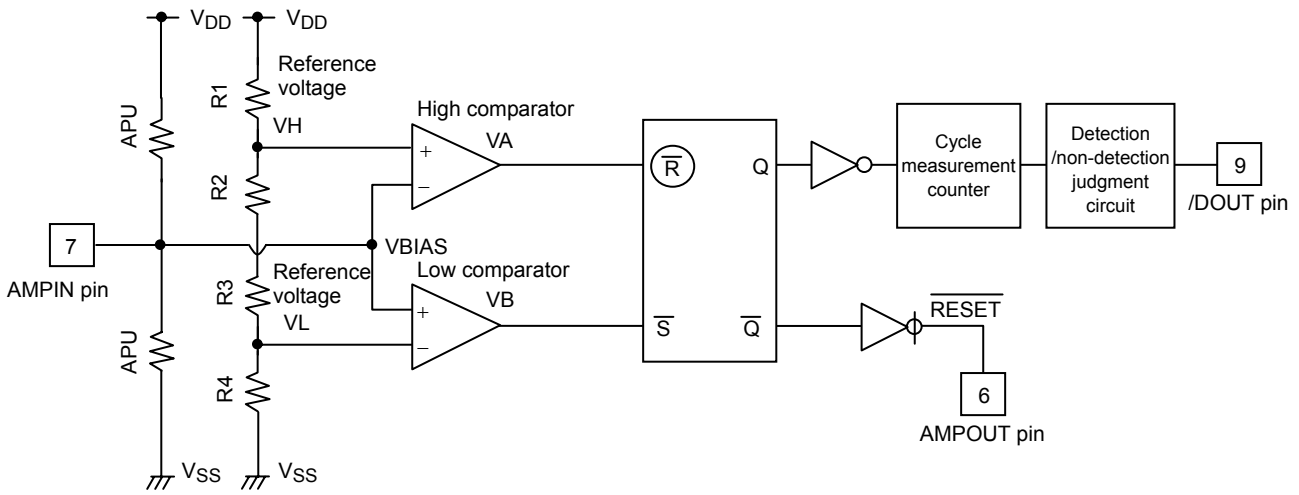

AMP IN input sine waveform

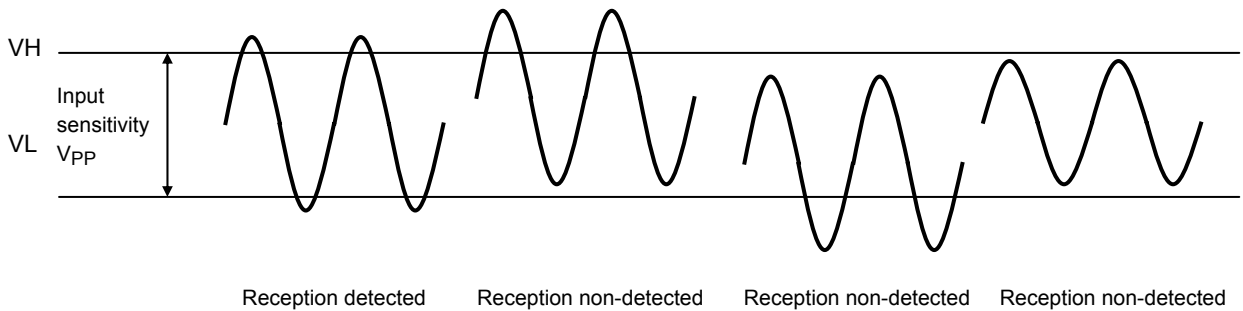

AMPOUT output timing (/RESET = L)

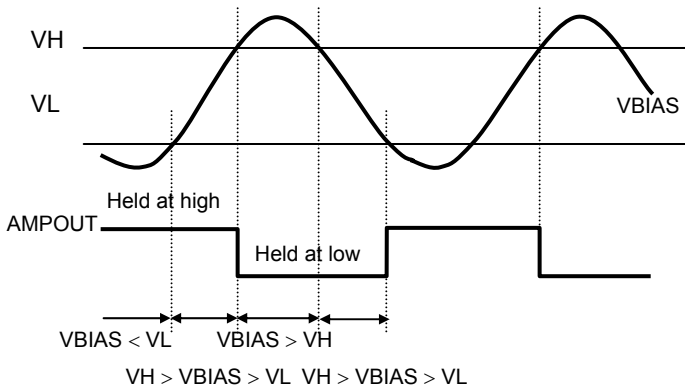

AMPOUT Truth Table

	VA	VB	AMPOUT
VBIAS > VH	L	H	L
VH > VBIAS > VL	H	H	Hold
VBIAS < VL	H	L	H

3. Transmission block function and timing

When the modulation control input (/SCTL) is in High-level, the pseudo sine wave output is held at 0° phase of the pseudo sine wave. When the modulation control input changes from High-level to Low-level, the pseudo sine wave output (SOUT+) initially outputs from -90° (SOUT- outputs from +90°).

The time required to turn ON in this case is as follows:

$$t_d(\text{ON}) < 500 \text{ ns}$$

When modulation control input changes from Low-level to High-level, the phase is forcibly held at 0° (the pseudo sine wave output is stopped), regardless of the phase of the pseudo sine wave output. The time required to turn OFF in this case is as follows:

$$t_d(\text{OFF}) < 1 \mu\text{s}$$

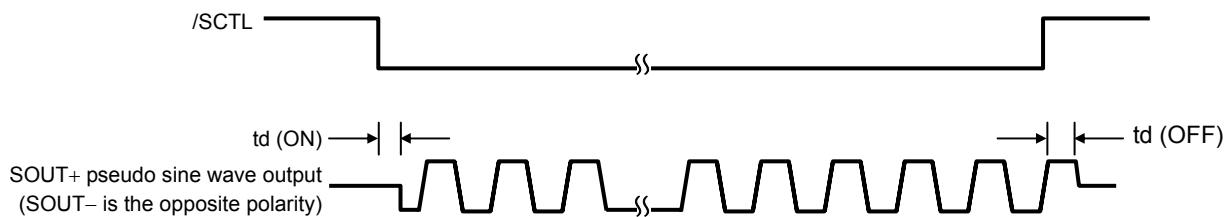

4. Reception block function and timing

Once it is okay to receive the amplifier input signal, the time it takes for the /DOUT pin to changes from High to Low (T (DET)) is about 9 to 15 waves (based on F_{OSC} 1/16 frequency). This condition is only valid when the cyclic input signal within the range specified by the frequency window is detected (or not detected) in continuation.

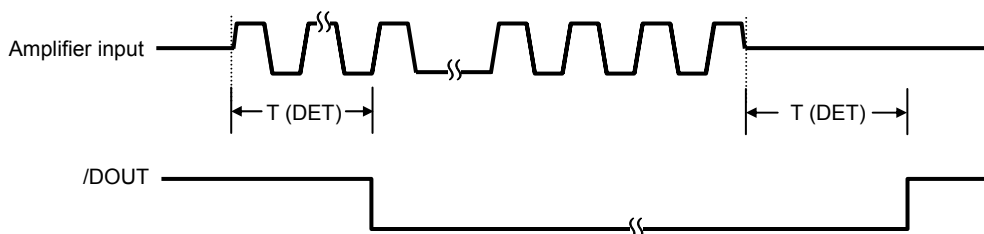

Note 1: You are free to use any kind of communication protocol you wish, however be sure to configure a time of carrier wave × 15 waves or more for both when there are and aren't signals.

Timing Chart (SOUT+ = SW1IN, SW1OUT, SOUT- = SW2IN, SW2OUT)

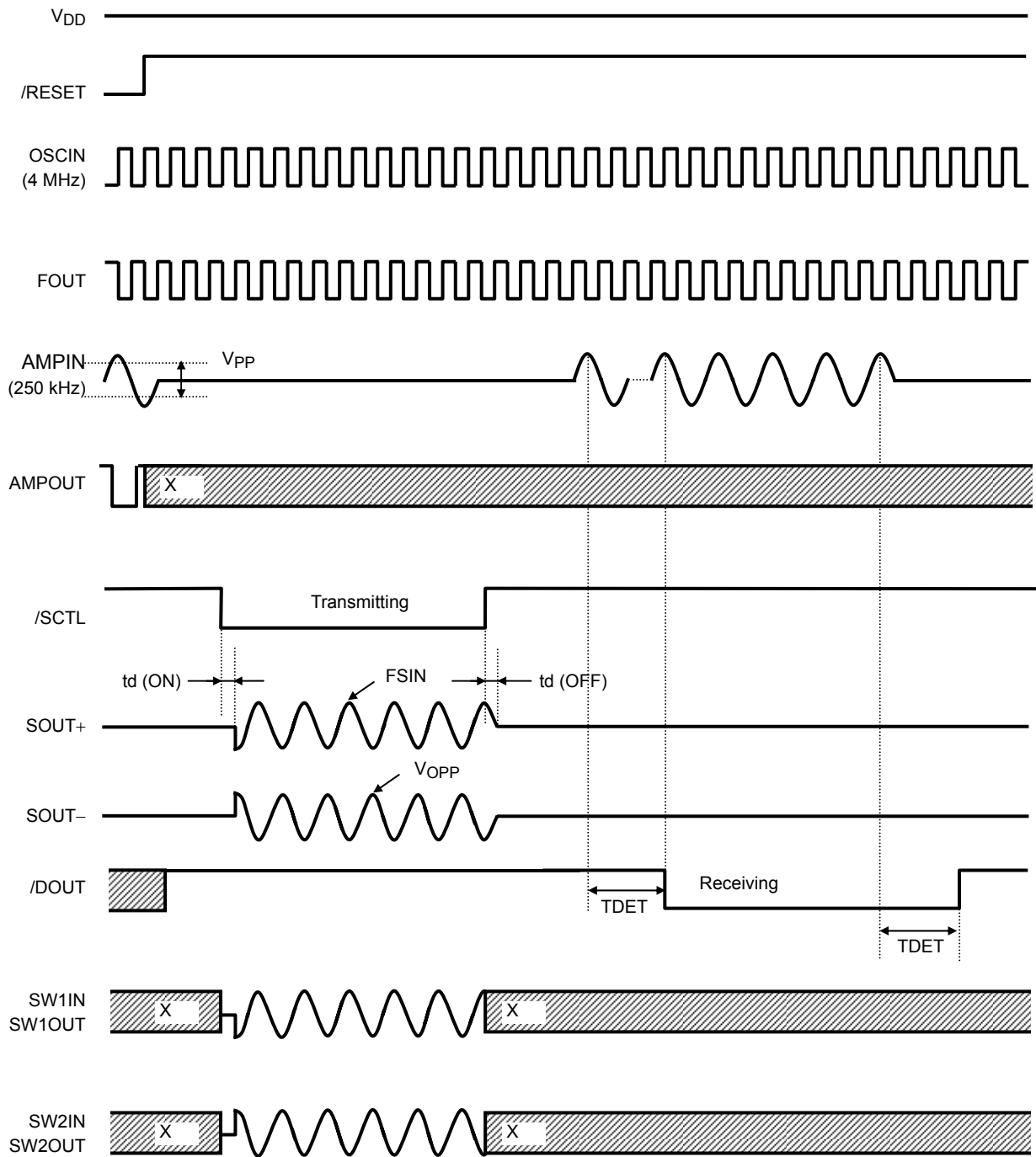

Absolute Maximum Ratings (Ta = 25 ± 1.5°C)

Characteristics	Symbol	Rating	Unit
Power supply voltage	V _{DD}	-0.3 to 6.0	V
Input voltage	V _I	-0.3 to V _{DD} + 0.3	V
Input peak current	I _{IK}	-20 to 20	mA
Operating temperature	T _{opr}	-20 to 80	°C
Storage temperature	T _{stg}	-55 to 125	°C
Power dissipation	P _D (Note 1)	0.54	W

▲CAUTION

The absolute maximum ratings of a semiconductor device are a set of ratings that must not be exceeded, even for a moment. Do not exceed any of these ratings.

Exceeding the rating(s) may cause device breakdown, damage or deterioration, and may result in injury by explosion or combustion.

Note 1: Power dissipation decreases approximately 4.35 mW per degree (Centigrade).

Electrical Characteristics

(unless otherwise specified, $V_{DD} = 5.0\text{ V}$, $V_{SS} = 0\text{ V}$, $F_{OSC} = 4\text{ MHz}$ and $T_a = -20\text{ to }80^\circ\text{C}$)

Characteristics		Symbol	Test Circuit	Test Condition	Min	Typ.	Max	Unit
V _{DD} pin (pin 16)								
Operating voltage		V _{DD}	—		4.5	5.0	5.5	V
Current consumption		I _{DD}	1	When there is no load; F _{OSC} = 4 MHz	—	—	10	mA
OSCIN pin (pin 1) and OSCOUT pin (pin 2)								
Oscillation frequency		F _{OSC}	2		1	4	10	MHz
Input voltage	High level	VIHOSC	3		0.7 V _{DD}	—	V _{DD}	V
	Low level	VILOSC	3		V _{SS}	—	0.3 V _{DD}	
Input current	High level	IIHROSC	4	V _{IN} = 5 V, T _a = 25°C	3.2	6.58	13.2	μA
	Low level	IILROSC	4	V _{IN} = 0 V, T _a = 25°C	-3.2	-6.58	-13.2	
Output voltage	High level	VOHOSC	3	IOH = -0.1 mA	V _{DD} - 1	—	V _{DD}	V
	Low level	VOLOSC	4	IOL = +0.1 mA	V _{SS}	—	V _{SS} + 0.6	
/RESET pin (5 pin)								
Low to High input switching level		VIHRST	5		0.65 V _{DD}	—	V _{DD}	V
High to Low input switching level		VILRST	5		V _{SS}	—	0.35 V _{DD}	V
High-level input current		IIHRST	6	V _{IN} = V _{DD}	-10	—	10	μA
Pull-up resistance 1		IILRRST1	7	V _{IN} = V _{SS} , T _a = 25°C	9	15	21	kΩ
Pull-up resistance 2		IILRRST2	7	V _{IN} = V _{SS} , T _a = -20 to 80°C	6.3	—	27.3	kΩ
/SCTL pin (pin 4)								
Low to High input switching level		VIHSCTL	8		0.65 V _{DD}	—	V _{DD}	V
High to Low input switching level		VILSCTL	8		V _{SS}	—	0.35 V _{DD}	V
Input current	High level	IIHSCTL	9	V _{IN} = V _{DD}	-1	—	1	μA
	Low level	IILSCTL	9	V _{IN} = V _{DD}	-1	—	1	
FOUT pin (pin 3)								
Output voltage	High level	VOHFOUT	10	IOH = -1.0 mA	V _{DD} - 1	—	V _{DD}	V
	Low level	VOLFOUT	11	IOL = +1.0 mA	V _{SS}	—	V _{SS} + 0.6	
/DOUT pin (pin 9)								
Output voltage	High level	VOHDOUT	12	IOH = -1.0 mA	V _{DD} - 1.0	—	V _{DD}	V
	Low level	VOLDOUT	13	IOL = +1.0 mA	V _{SS}	—	V _{SS} + 0.6	
Non-reception to reception detection time		TDET1	19	F _{OSC} = 4 MHz, AMPIN = 250 kHz Time it takes for /DOUT to change from High to Low	40	—	60	μs
Reception to non-reception detection time		TDET2	19	F _{OSC} = 4 MHz, AMPIN = 250 kHz Time it takes for /DOUT to change from Low to High	36	—	56	μs

Note: The direction of current flow should be + (sink) when flowing into the IC and - (drain) when flowing out of the IC.

Characteristics	Symbol	Test Circuit	Test Condition	Min	Typ.	Max	Unit
AMPIN pin (pin 7)							
Input dynamic range	VAMPIN	14		V_{SS}	—	V_{DD}	V
Pull-up resistance 1	IILRAPU1	15	$V_{IN} = V_{SS}$, $T_a = 25^\circ\text{C}$	11.6	19.4	27.2	$\text{k}\Omega$
Pull-up resistance 2	IILRAPU2	15	$V_{IN} = V_{SS}$, $T_a = -20$ to 80°C	7	—	38	$\text{k}\Omega$
Pull-down resistance 1	IIHRAPD1	16	$V_{IN} = V_{DD}$, $T_a = 25^\circ\text{C}$	5.9	9.8	13.7	$\text{k}\Omega$
Pull-down resistance 2	IIHRAPD2	16	$V_{IN} = V_{DD}$, $T_a = -20$ to 80°C	3	—	19.2	$\text{k}\Omega$
Amplifier input bias voltage	VBIAS	17	No load (design target)	1.54	1.63	1.71	V
Amplifier input sensitivity	VPP	18	No load, receivable amplitude range is 250 kHz, when sine wave signal is applied. (design target)	0.3	—	0.45	V
Detection frequency range	DETON	19	$F_{OSC} = 4$ MHz	236	—	266	kHz
Non-detection frequency (low frequency)	DETOFF1	19	$F_{OSC} = 4$ MHz	—	—	236	kHz
Non-detection frequency (high frequency)	DETOFF2	19	$F_{OSC} = 4$ MHz	266	—	—	kHz
SW1IN pin (pin 14) and SW1OUT pin (pin 15)							
Analog switch input voltage	VINASW1	—		V_{SS}	—	V_{DD}	V
Analog switch output voltage	VOUTASW1	—		V_{SS}	—	V_{DD}	V
OFF-leak current of analog switch 1	IOFFASW1	20	/SCTL = H, SW1IN = V_{DD} , SW1OUT = V_{SS}	-1	—	1	μA
ON-resistance of analog switch 1	RONASW1	21	/SCTL = L, SW1IN = 5 V, SW1OUT = 0 V Current measure	35	—	105	Ω
SW2IN pin (pin 11) and SW2OUT pin (pin 10)							
Analog switch input voltage	VINASW2	—		V_{SS}	—	V_{DD}	V
Analog switch output voltage	VOUTASW2	—		V_{SS}	—	V_{DD}	V
OFF-leak current of analog switch 2	IOFFASW2	20	/SCTL = H, SW2IN = V_{DD} , SW2OUT = V_{SS}	-1	—	1	μA
ON-resistance of analog switch 2	RONASW2	21	/SCTL = L, SW2IN = 5 V, SW2OUT = 0 V Current measure	35	—	105	Ω
SOUT+ pin (13 pin), SOUT- pin (12 pin)							
Output voltage	VOPP	22	Maximum voltage value when there is no load	$0.85 V_{DD}$	—	V_{DD}	V
Pseudo sine wave output frequency	FSIN	23	$F_{OSC} = 4$ MHz	—	250	—	kHz
Pseudo sine wave output start time	tdON	23	/SCTL = H \rightarrow L	—	—	500	ns
Pseudo sine wave output stop time	tdOFF	23	/SCTL = L \rightarrow H	—	—	1	μs
Equivalent output impedance	ROUTSIN	24	No load	2.8	4	5.2	$\text{k}\Omega$

Note: The direction of current flow should be + (sink) when flowing into the IC and - (drain) when flowing out of the IC.

Test Circuit

(1) Current consumption

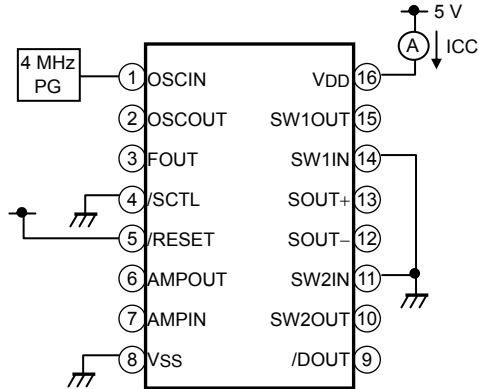

(2) Oscillation frequency

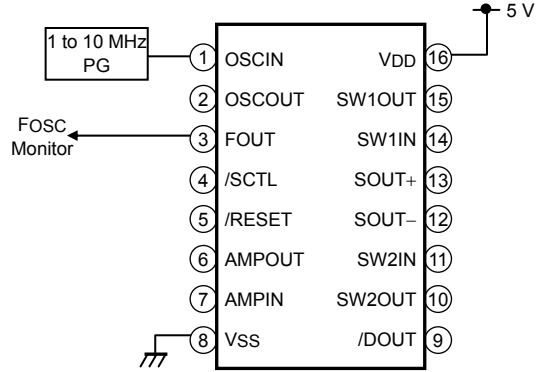

**(3) High-level input voltage
Low-level input voltage
High-level output voltage**

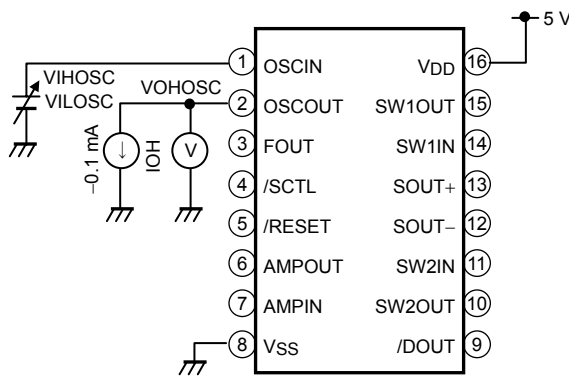

**(4) High-level input current
Low-level input current
Low-level output voltage**

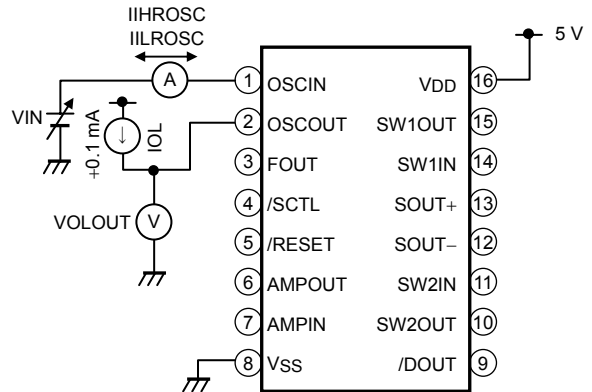

**(5) Low to High input switching level
High to Low input switching level**

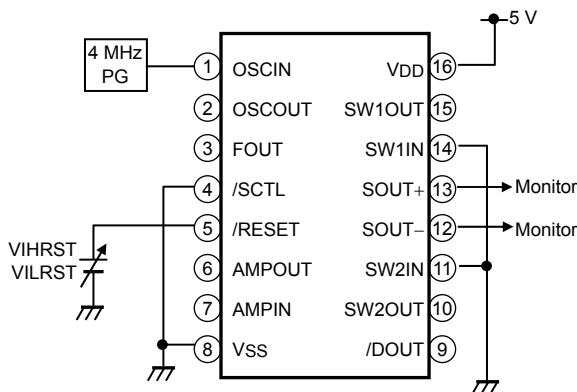

(6) High-level input current

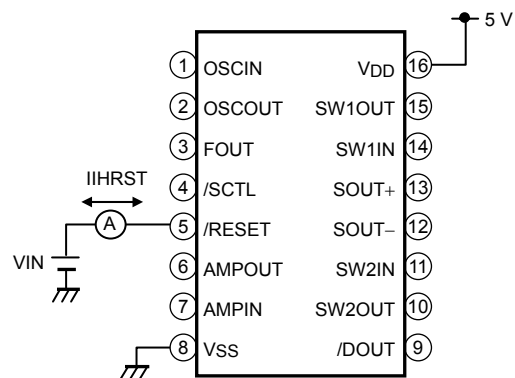

**(7) Pull-up resistance 1
Pull-up resistance 2**

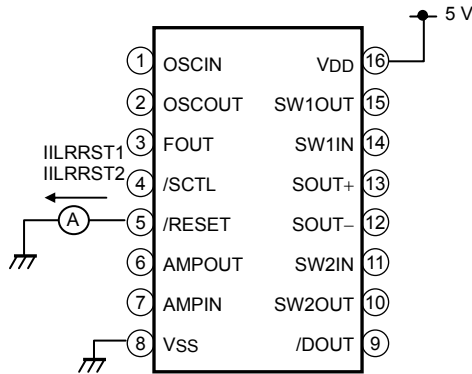

**(8) Low to High input switching level
High to Low input switching level**

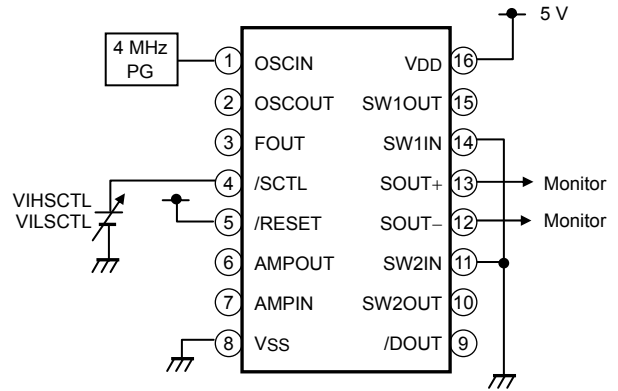

**(9) High-level input current
Low-level input current**

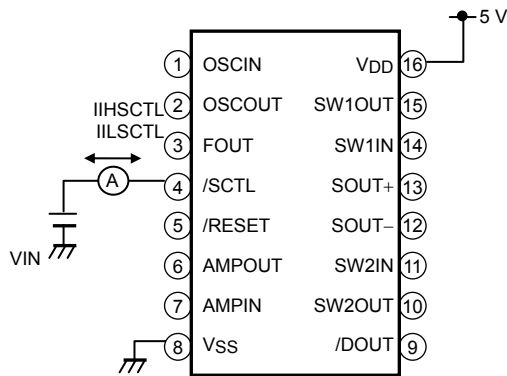

(10) High-level output voltage

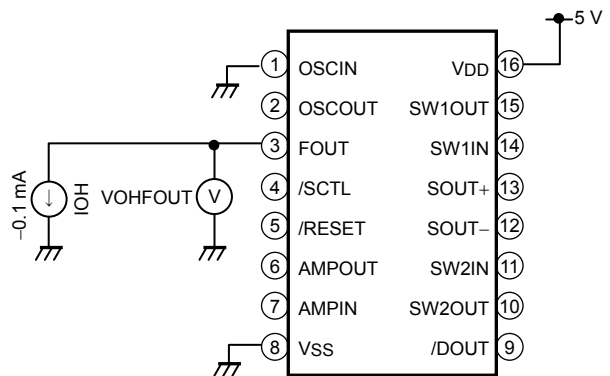

(11) Low-level output voltage

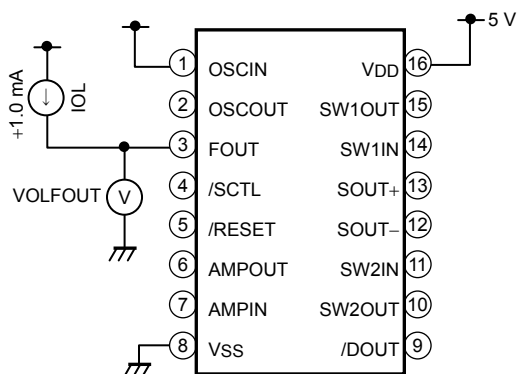

(12) High-level output voltage

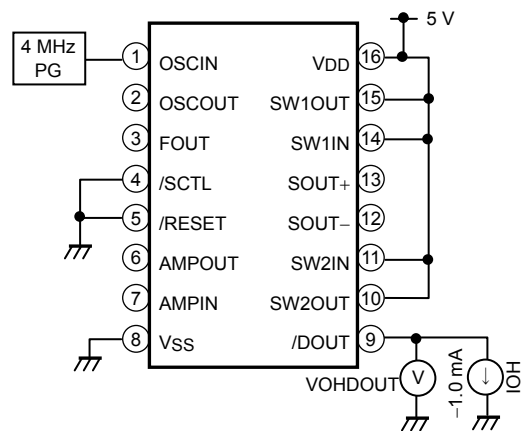

(13) Low-level output voltage

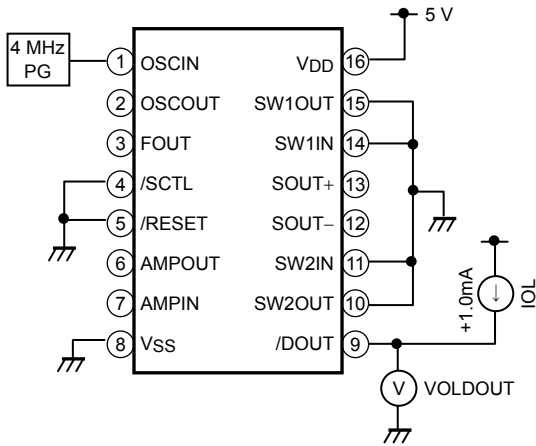

(14) Input dynamic range

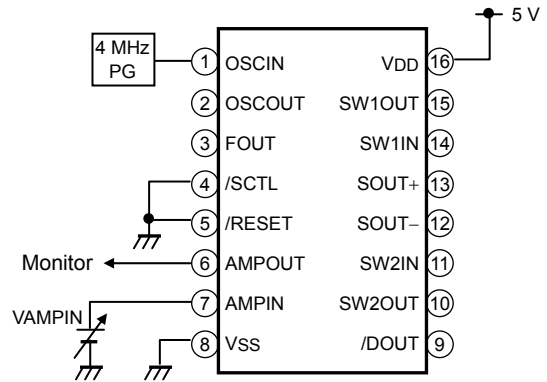

**(15) Pull-up resistance 1
Pull-up resistance 2**

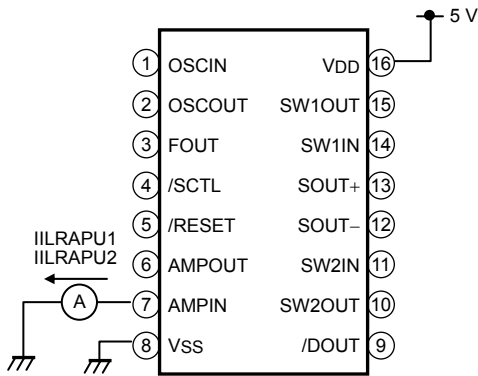

**(16) Pull-down resistance 1
Pull-down resistance 2**

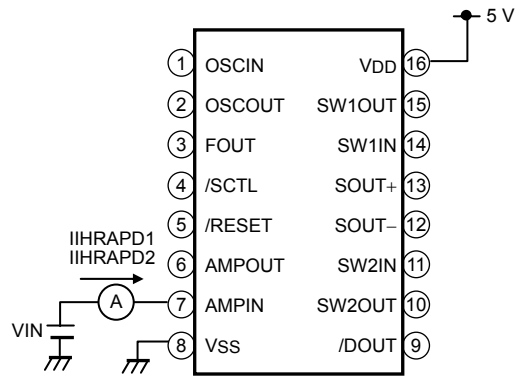

(17) Amplifier input bias voltage

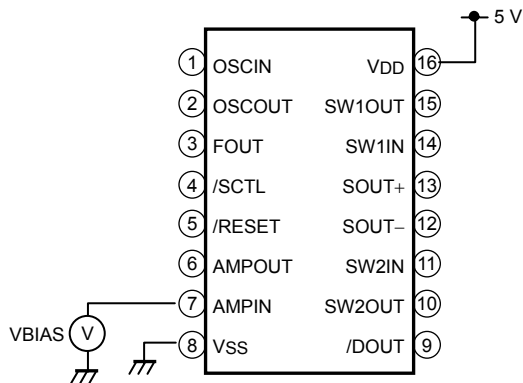

(18) Amplifier input sensitivity

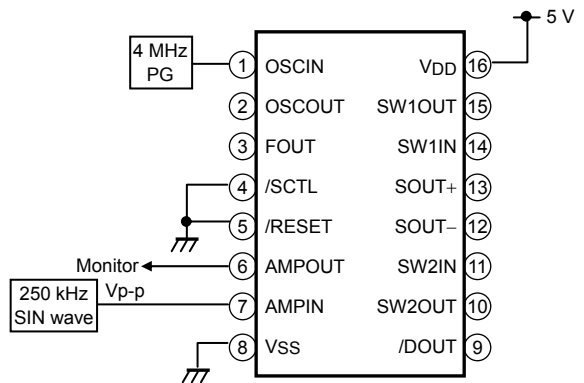

- (19) Detection frequency range
- Non-detection frequency (low frequency)
- Non-detection frequency (high frequency)
- Non-reception to reception detection time
- Reception to non-reception detection time

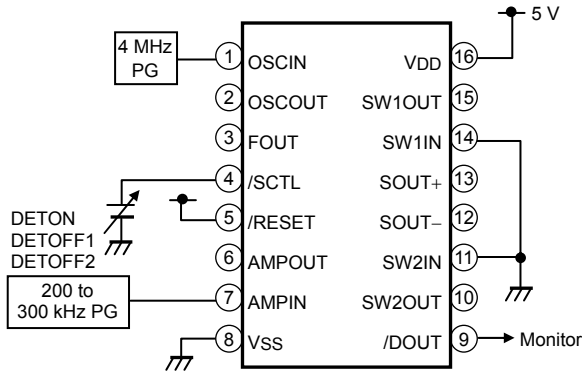

- (20) OFF-leak current of analog switch 1
- OFF-leak current of analog switch 2

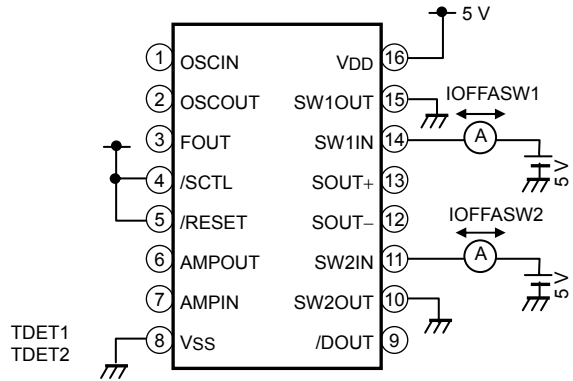

- (21) ON-resistance of analog switch 1
- ON-resistance of analog switch 2

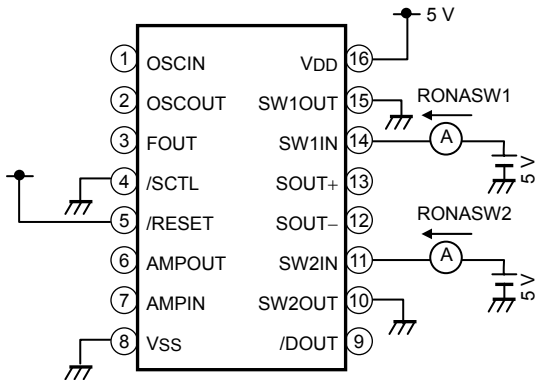

- (22) Output voltage

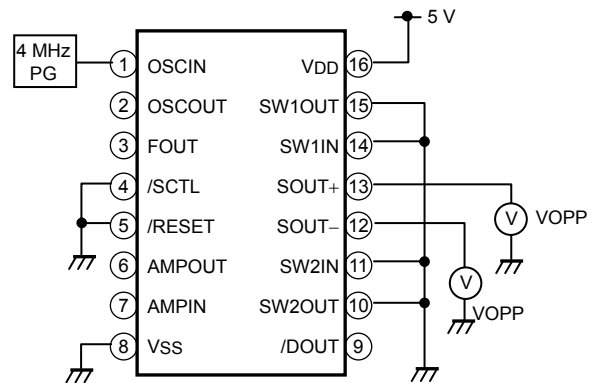

- (23) Pseudo sine wave output frequency
- Pseudo sine wave output start time
- Pseudo sine wave output stop time

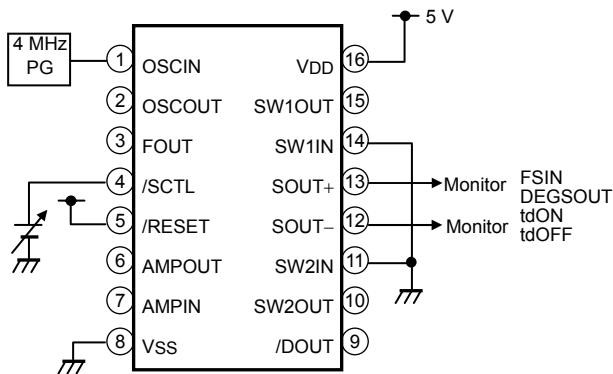

- (24) Equivalent output impedance

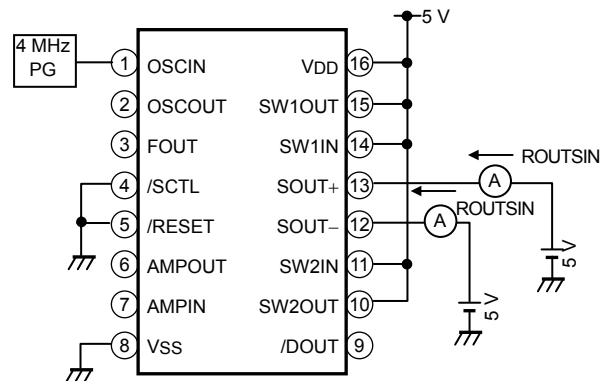

IC Marking Specification



Toshiba CMOS SOP Embossed Taping - Common Specifications

1. Applicable Scope

This specification defines the embossed taping package specifications and related items for Toshiba flat package CMOS ICs. As a rule, these taping specifications comply with JEITA (RC-1009B) and EIA (EIA481).

2. Specifications

2.1 Tape Form and Dimensions

Package	JEITA Tape Standard
300 mm 14, 16 pin (JEITA Type II)	TE1612
300 mm 20 pin (JEITA Type II)	TE2412

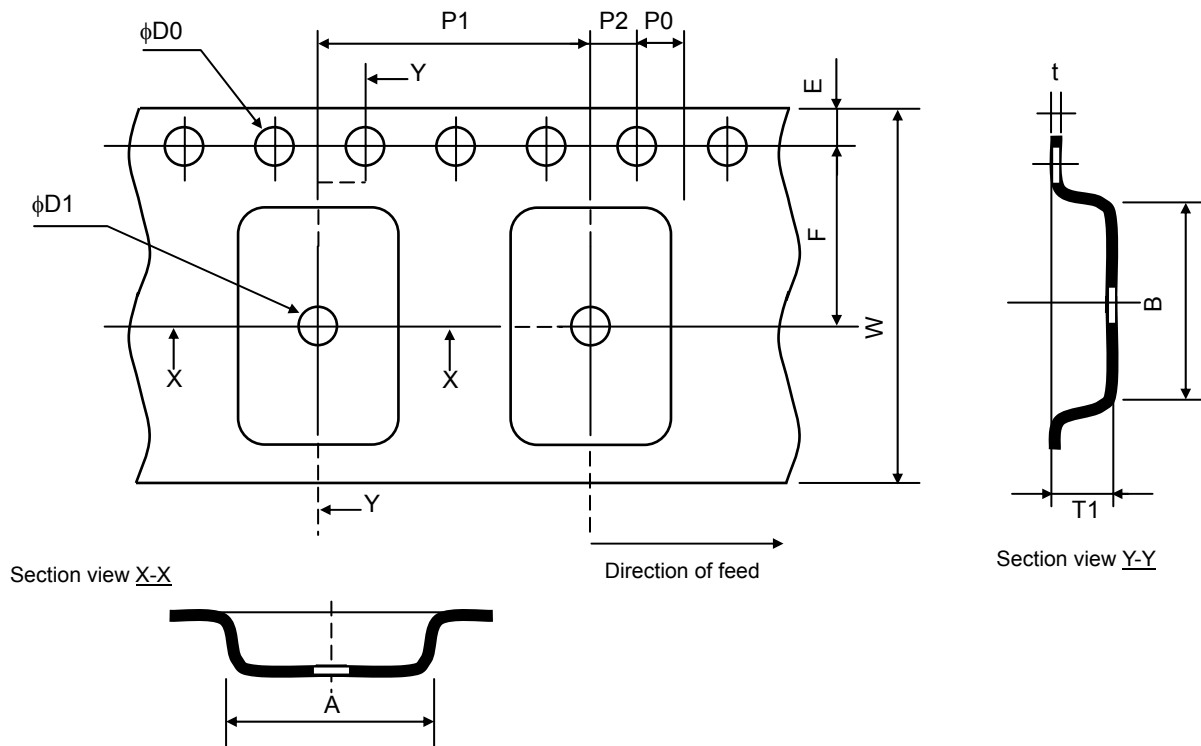

Unit: mm

	A	B	W	F	E	P1	P2	P0	$\phi D0$	t	T1	$\phi D1$
14, 16 pin type	8.5 ± 0.2	10.8 ± 0.2	16.0 ± 0.3	7.5 ± 0.1	1.75 ± 0.1	12.0 ± 0.1	2.0 ± 0.1	4.0 ± 0.1	1.5 $+0.1$ -0	0.3 ± 0.1	2.1 ± 0.2	1.65 ± 0.1
20 pin type	8.3 ± 0.2	13.2 ± 0.2	24.0 ± 0.3	11.5 ± 0.1	1.75 ± 0.1	12.0 ± 0.1	2.0 ± 0.1	4.0 ± 0.1	1.5 $+0.1$ -0	0.3 ± 0.1	2.2 ± 0.2	2.0 ± 0.2

Note 1: The tape surface resistance shall be $10^6 \Omega/\text{cm}$ or less.

Note 2: The accumulated error tolerance for the feed hole pitch (P0) shall be $\leq \pm 0.2$ mm per 10 pitches.

2.2 Seal Tape Dimensions

Unit: mm

	Tape Width	Tape Thickness
14,16 pin type	13.5	0.06
20 pin type	21.5	0.06

2.3 Reel Form and Dimensions

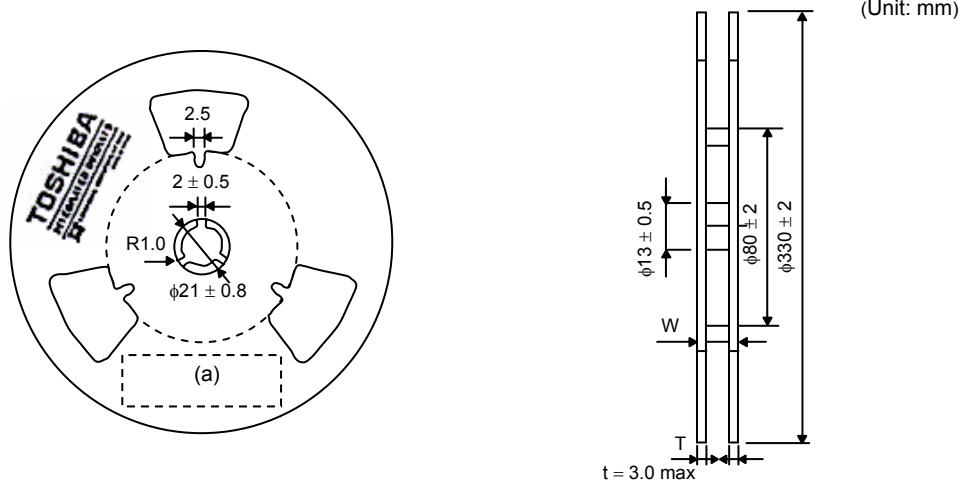

Unit: mm

W dimension	14,16 pin	16.4 ^{+2.0} ₋₀
	20 pin	24.4 ^{+2.0} ₋₀

(a) Bar code label (See page 18)

2.4 Insertion Direction

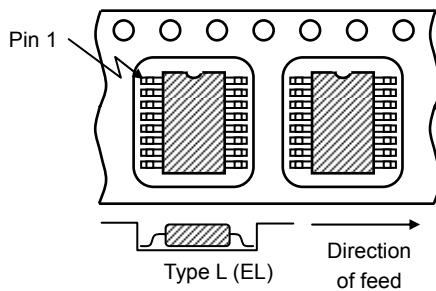

2.5 Tape Minimum Bending Radius

The strength of the seal tape shall not change even when an IC is inserted into the tape and the tape is bent 40 mm. In addition, the tape and inserted IC shall not change under the corresponding conditions.

2.6 Seal Tape Peeling Strength

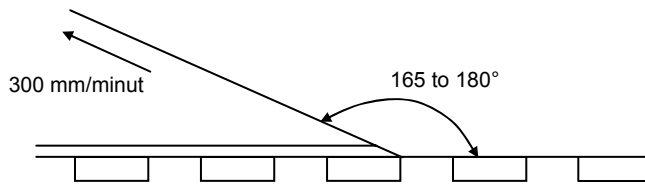

The seal tape shall maintain a peeling strength of 0.1 N (10 gf) when tape bonding surface is at 165 to 180° and being pulled at a speed of 300 mm per minute. However, the seal tape shall not fracture or break when it is being peeled.

2.7 Leader and Trailer Sections of the Tape

Empty cavities shall be created in leader and trailer sections of the tape in which ICs shall not be inserted as specified below:

	Seal Tape	Carrier Tape
Leader section	Minimum of 500 mm	Minimum of 400 mm
Trailer section	Minimum of 400 mm	Minimum of 400 mm

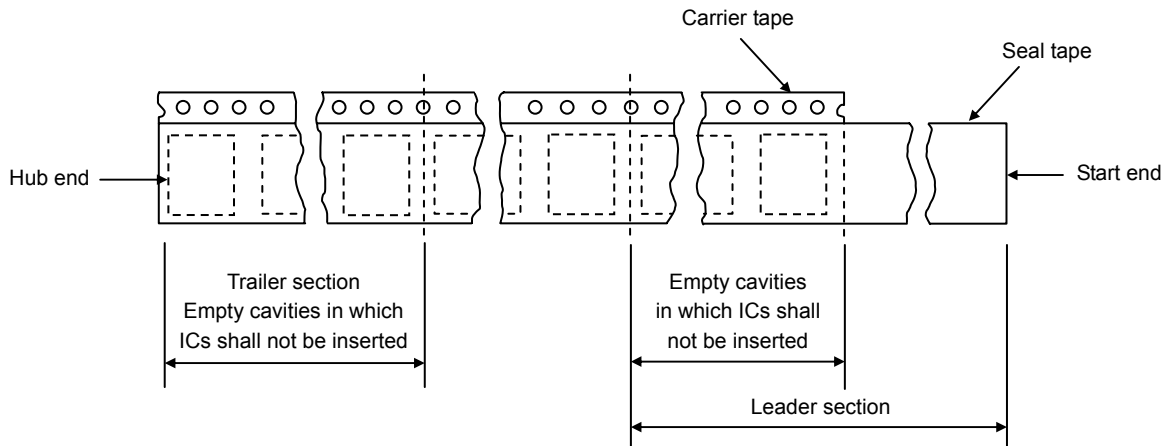

2.8 IC Insertion Failure Ratio

Item	Tolerated Ratio	Comments
Consecutive insertion failure	None	Does not apply to the empty cavities in the leading and trailing sections of the tape.
Non-consecutive insertion failure	0.1 % or less (per reel)	

3. Standard Packaging Unit

The standard packaging unit for one reel of tape shall be 2000 units.

4. Labeling

The reel shall be labeled with the following:

- 1) Product Name
- 2) Quantity
- 3) Lot No.

5. Boxing

Each completed reel of tape shall be boxed in a cardboard box (one per box). The box shall also be labeled with the same labeling information as the reel (see above).

Dimensions	Unit: mm		
	A	B	C
14, 16 pin type	340	25	27
20 pin type	340	33	35

Bar code label

P/N:				TOSHIBA	
TYPE	T6B70BFG		Use under 30degC/70%RH within 168h SEALED Mmm,dd,yyyy		
ADDQ	(EL,B,PD)		Q'TY	PCS	[[G]]/RoHS COMPATIBLE DIFFUSED IN JAPAN ASSEMBLED IN JAPAN
					

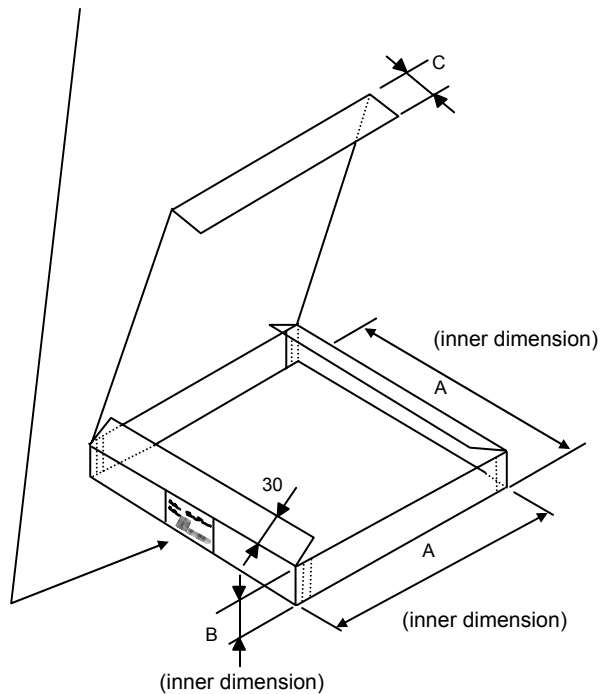

6. Issuing Purchase Orders

When issuing IC purchase orders using the taping packaging information, be sure to include the product name, taping type, insertion direction and quantity as follows:

Example:

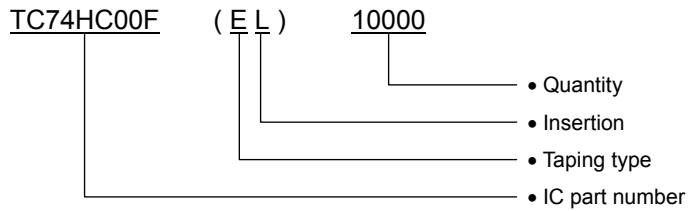

7. Delivery and Storage Precautions

Tape reels should be delivered with enough care so as to prevent extreme vibration from impacting the product. Tape reels should be kept out of direct sunlight and be kept below 45°C during delivery and storage so as to prevent wearing down the peeling strength of seal tape and/or causing other deformities to the tape.

Package Dimensions

SOP16-P-300-1.27

Unit : mm

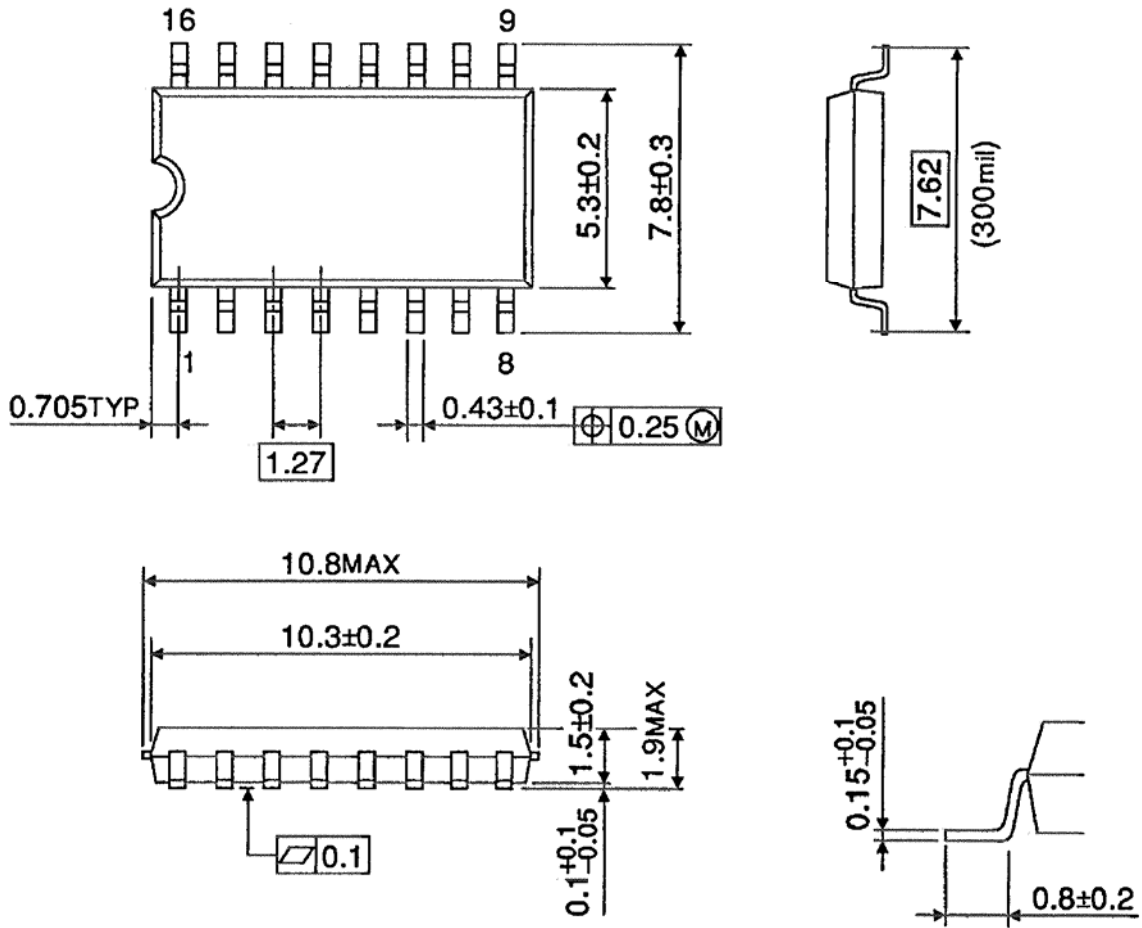

Weight: 0.16 g (typ.)

About solderability, following conditions were confirmed

- Solderability

- (1) Use of Sn-37Pb solder Bath
 - solder bath temperature = 230°C
 - dipping time = 5 seconds
 - the number of times = once
 - use of R-type flux
- (2) Use of Sn-3.0Ag-0.5Cu solder Bath
 - solder bath temperature = 245°C
 - dipping time = 5 seconds
 - the number of times = once
 - use of R-type flux

RESTRICTIONS ON PRODUCT USE

070711EBA

- The information contained herein is subject to change without notice.
- TOSHIBA is continually working to improve the quality and reliability of its products. Nevertheless, semiconductor devices in general can malfunction or fail due to their inherent electrical sensitivity and vulnerability to physical stress. It is the responsibility of the buyer, when utilizing TOSHIBA products, to comply with the standards of safety in making a safe design for the entire system, and to avoid situations in which a malfunction or failure of such TOSHIBA products could cause loss of human life, bodily injury or damage to property.
In developing your designs, please ensure that TOSHIBA products are used within specified operating ranges as set forth in the most recent TOSHIBA products specifications. Also, please keep in mind the precautions and conditions set forth in the "Handling Guide for Semiconductor Devices," or "TOSHIBA Semiconductor Reliability Handbook" etc..
- The TOSHIBA products listed in this document are designed and manufactured for usage in hot water dispensers. Do not use any of these products for any purposes other than hot water dispensers, unless otherwise agreed in writing by TOSHIBA.
- The products described in this document shall not be used or embedded to any downstream products of which manufacture, use and/or sale are prohibited under any applicable laws and regulations.
- The information contained herein is presented only as a guide for the applications of our products. No responsibility is assumed by TOSHIBA for any infringements of patents or other rights of the third parties which may result from its use. No license is granted by implication or otherwise under any patents or other rights of TOSHIBA or the third parties.
- Please use this product in compliance with all applicable laws and regulations that regulate the inclusion or use of controlled substances. Toshiba assumes no liability for damage or losses occurring as a result of noncompliance with applicable laws and regulations.
- The products described in this document are subject to foreign exchange and foreign trade control laws.